

# SERIES 16G

Small in Size, Big in Features

Commercial, Gas Fired,  
Atmospheric,  
Hot Water Boiler



- Four sizes from 340 to 505 MBH input
- Thermal efficiency ratings up to 81%
- Cast iron sections and cast iron push nipples
- Atmospheric vent design
- Available with CSD-1 electronic control set (models 16G - 460/505 only)
- Combustible floor installation with optional base
- Controls under jacket for security and a clean appearance
- Shipped semi-packaged for convenience
- LP available
- Compact unit is easy to move and fits through standard doorways
- Easily configurable for multiple boiler applications



The Mega-Stor II indirect water heaters come in a variety of sizes from 30 to 119 gallons to meet a variety of residential and commercial needs.



[VelocityBoilerWorks.com](http://VelocityBoilerWorks.com) | Philadelphia, PA

# SERIES 16G TECHNICAL SPECIFICATIONS

MODEL NUMBER	DIMENSIONS (IN.)				
	A	B	C	D	E
16G-340	27-1/2	13-3/4	8	27-13/16	18
16G-399	31-1/4	15-5/8	9	30-13/16	20
16G-460	35	17-1/2	10	33-1/2	22
16G-505	38-3/4	19-3/8	10	33-1/2	22

- Not for direct installation on combustible flooring. A heat shield is required and available for installation on combustible floors and on concrete.
- External draft hood supplied - may not be cut or altered.

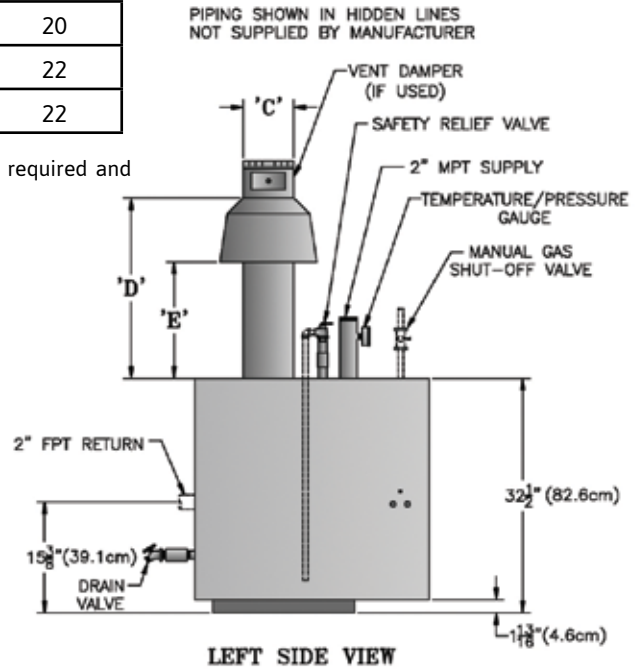
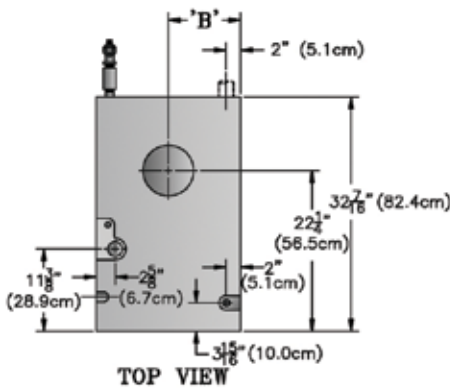

MODEL NUMBER	INPUT (MBH) <sup>1</sup>	HEATING CAPACITY (MBH)	AHRI NET RATING WATER (MBH) <sup>2</sup>	THERMAL EFFICIENCY (%)	WATER CONTENT (GAL)	APPROX (KNOCKDOWN) SHIPPING WEIGHT (LBS)	CSD-1 AVAILABLE
16G-340	340	275	239	81.0	15.9	870	N/A
16G-399	399	320	278	80.2	17.9	955	N/A
16G-460	460	370	322	80.4	19.9	1050	YES
16G-505	505	406	353	80.5	21.9	1150	YES

- Input ratings can be used for elevations up to 2,000 ft for sea level builds. For high altitude builds, input ratings shall be derated by 3.6% per 1,000 ft. above sea level.
- Net AHRI Ratings shown are based on a piping and pickup allowance of 1.15. The manufacturer should be consulted before selecting a boiler for installations having unusual piping and pickup requirements, such as intermittent operation, extensive piping systems, etc.

All Series 16G boiler models include a full one-year warranty. A 10-year limited warranty is provided for the heat exchanger. Visit [VelocityBoilerWorks.com](http://VelocityBoilerWorks.com) for details.

Specifications are subject to change without notice.

### STANDARD EQUIPMENT

- 50 PSI safety relief valve
- Probe-style manual reset low water cutoff (models 16G-410/460/505 only)

### OPTIONAL EQUIPMENT

- Base for installation on combustible floors
- Vent damper (not available on CSD-1 builds)

