

CROWN

PROFILE

GAS FIRED HOT WATER WALL HUNG BOILERS

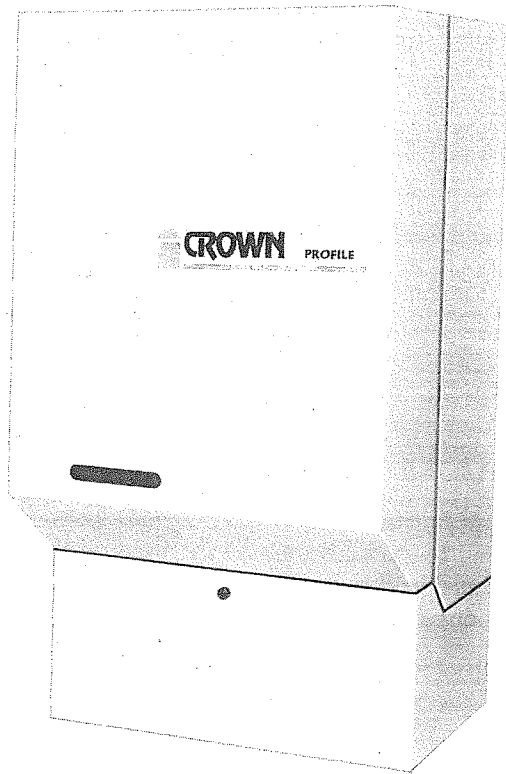

- INSTALLATION
AND OPERATING
INSTRUCTIONS
- MAINTENANCE
- PARTS

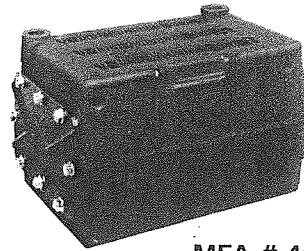

MEA # 461-91-E



Design certified by
American Gas Association



Heating capacities based on
standard test procedures
prescribed by the United States
Department of Energy



Built in accordance
with the requirements
of the ASME Boiler and
Pressure Vessel Code



Canadian Gas Association

Table of Contents

SECTION	PAGE
I. Product Description	1
II. Boiler Ratings and Specifications	1
III. Before Starting Installation	3
IV. When Your Shipment Arrives	3
V. Locating Boiler	3
VI. Hanging Boiler	5
VII. Water System Piping	8
VIII. Completing Boiler Assembly	9
IX. Gas Piping	10
X. Electrical Wiring	11
XI. Start-up and Check-out	16
XII. Maintenance	18
XIII. Troubleshooting	19
Appendix A	27
Appendix B - Replacement Parts	28

I. PRODUCT DESCRIPTION

Crown PF series boilers are direct vent gas fired wall mounted boilers designed for hot water space heating only.

The PF incorporates a one piece cast iron heat exchanger. All air for combustion is obtained from outdoors via the opening between two concentric tubes. Flue gases are exhausted to the outdoors via the inner of the two concentric tubes. There is no communication of air between the boiler and the indoor space, making this boiler ideal for tightly insulated construction and other applications where an adequate source of clean indoor combustion air cannot be guaranteed.

II. BOILER RATINGS AND SPECIFICATIONS

TABLE 1: BOILER RATINGS & CAPACITIES

Boiler Model	Type Gas	AGA Input BTU/HR.	DOE Heating Capacity BTU/HR.	IBR NET Water Rating BTU/HR.	AFUE (%)	Shipping Wght. Lbs.
PF-50	Natural or LP	50,000	42,000	37,000	82.1	190
PF-65	Natural or LP	65,000	55,000	48,000	83.0	190
PF-82	Natural or LP	82,000	68,000	59,000	82.6	190

USA - For altitudes above 2,000 ft. ratings should be reduced at the rate of 4% for each 1,000 ft. above sea level.

Heating capacity is based upon DOE (Department of Energy) test procedure.

CANADA - For Altitudes above 2000 feet - Consult Factory

FIG 1a: FRONT VIEW SIDE VENTED

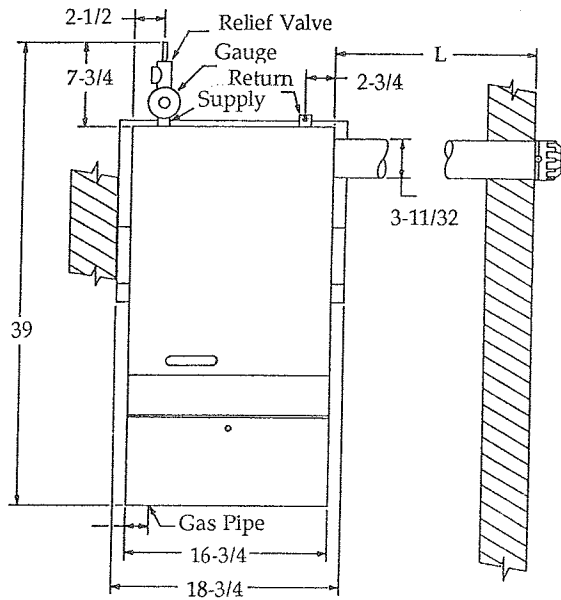

All dimensions $\pm 1/8"$

FIGURE 1b: Side View Rear Vented

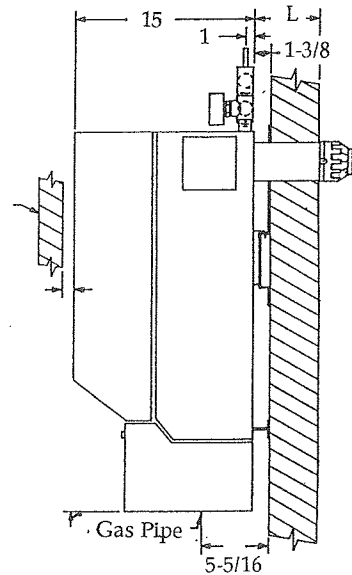

TABLE 2:

VENT RESTRICTIONS (Inches)	
	L
Standard Length	min.: 5-3/8
	max.: 21-1/16
Optional Long Tube	min. 5-3/8
	max. 78

TABLE 3:

TAPPINGS (Inches NPT)		
Supply	3/4	*Female
Return	3/4	*Female
Gas	1/2	Female

* With factory supplied fittings. Boiler is also shipped with (2) 3/4" NPT x 1" Female sweat adaptors

Water Content (All Sizes) 1.72 US Gallon

TABLE 4:

Minimum Clearances (inches)	
Sides	1
Front (to door or removable obstruction).....	1
Front (to non-removable obstruction)	24
Bottom	1-1/4
Casing Top*	9
Vent Terminal to Closest Construction (Horizontal)	96

* Relief valve must have sufficient clearance to ceiling so as to allow the relief valve lever to be fully raised. The above top clearance will allow this with the factory supplied piping installed according to these instructions.

III. BEFORE STARTING INSTALLATION

- 1) Be sure that boiler is of correct size and gas type (Natural or LP) required.
- 2) Read this installation manual completely.
- 3) Be sure that the planned installation is in accordance with all local codes. In the absence of any local codes, install this boiler in accordance with the National Fuel Gas Code Z223.1-1988. Where required by the authority having jurisdiction the installation must conform to the Standard for Controls and Safety Devices for Automatically Fired Boiler (ANSI/ASME CSD-1).

In Canada follow the Canadian Installation Codes for Gas Burning Equipment (CAN/CGA B149.1 and .2) as well as the Canadian Electrical Code, Part I CSA C22.1.

IV. WHEN YOUR SHIPMENT ARRIVES.

This boiler is shipped in two cartons as follows:

Carton A:

Main assembly including casing, heat exchanger, burner control system and control cover.

Carton B: (Carton B is the same for all size boilers)

- ✓Door
- ✓Fan assembly
- ✓Boiler hanging bracket
- ✓Vent components
- ✓Relief valve and tridicator
- ✓Relief valve tee
- ✓Installation manual
- ✓Fan assembly mounting screws
- ✓Wall hanging bracket mounting hardware
- ✓Silicone Sealant

Be certain that all of the above components are present before starting installation.

V. LOCATING BOILER.

- 1) Observe the vent tube length constraints outlined in Table 2.
- 2) Observe the minimum clearance from the boiler casing to other construction outlined in Table 4. Note that these minimum clearances will automatically be held if the minimum clearances to the bracket shown in Figure 2 are observed.
- 3) Vent terminal must be located no closer than:
 - ✓12" from any opening through which exhaust could enter building.
 - ✓12" above grade level.
 - ✓7ft. above a public walkway.
 - ✓4ft. horizontally to either side of electric meters, gas meters, regulators, and relief equipment.
- 4) Where-ever possible vent terminal should be located on the side of the structure facing away from the prevailing wind. This boiler is designed to operate with winds on the vent terminal of up to 40 mph. **Reliable operation at wind speeds above 40 mph cannot be guaranteed.**
- 5) Flue gases contain corrosive products which can condense on, and damage, construction near the vent terminal. For this reason avoid placing vent terminal under overhangs if at all possible. **Vent terminal cannot be extended beyond outside wall.**
- 6) Wall must be capable of supporting boiler.

WARNING

This boiler weighs approximately 200 lbs. installed. Failure to properly support it could result in property damage, injury, or death.

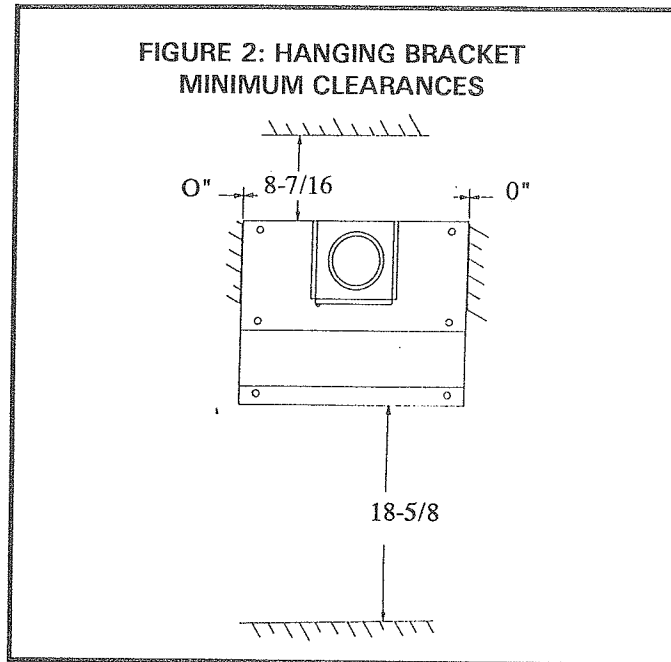

VI. HANGING BOILER.

1. Install mounting plate making sure it is both level & plumb:

- a) **Wood framed walls-** Boiler mounting plate is provided with 2 sets of holes on 16 inch centers for installation on a standard studded wall. If it is not possible to line these holes up with the studs, additional 3/8 holes may be located in the mounting plate. Once the mounting plate holes are located over studs, mark hole locations on wall. Drill pilot holes and mount hanging bracket using 5/16 x 2 lag screws and 5/16 washers provided. When drilling holes make sure that they are in center of stud.
- b) **Masonry walls-** After locating boiler mounting plate mark hole locations. Drill pilot hole and drive in 5/16 lag shields provided. Secure boiler mounting plate to wall using 5/16 x 2 lag screws and 5/16 washers provided.

WARNING

Because of the large variety of different materials used in wall construction, as well as the varying condition of older construction, it is ultimately the installer's responsibility to ensure that the above methods of attachment are suitable to the particular wall at the installation site.

- 2) **Vent tube opening**

Rear Vent Only - Lay out a 3 3/4" dia. hole in the center of boiler mounting plate vent opening. Cut out through wall being careful to keep hole straight.

Side Vent Only - Using horizontal center marks on mounting plate opening, extend a level line around corner. Lay out a vertical center line 5-1/4" in from corner (Fig. 3). Lay out a 4" dia. hole on this center line. Cut out being careful to keep hole straight.

- 3) **Vent tube preparation**

- a) **Cutting Rear Vent Tube Only** - Measure the wall thickness from its outside face to the inside face of the mounting plate (Fig. 4a). Add 2-3/8 inches to this dimension. Measure the total length from the flanged end of the vent tubes and cut squarely.

- a) **Cutting Side Vent Tube Only** - Measure through the vent hole from the outside wall face to the vertical center line of the boiler mounting plate (Fig. 4b). Subtract 7-1/4 inches from this dimension. Measure this length from the flanged end of the vent tube and cut squarely. Slip rope sealing ring over vent tube and up to flange.

NOTE

It is easier to cut the vent tubes if the vent terminal is temporarily placed on the end of the vent tube. The terminal can be held on with tape and will support the inner vent tube, resulting in a squarer cut.

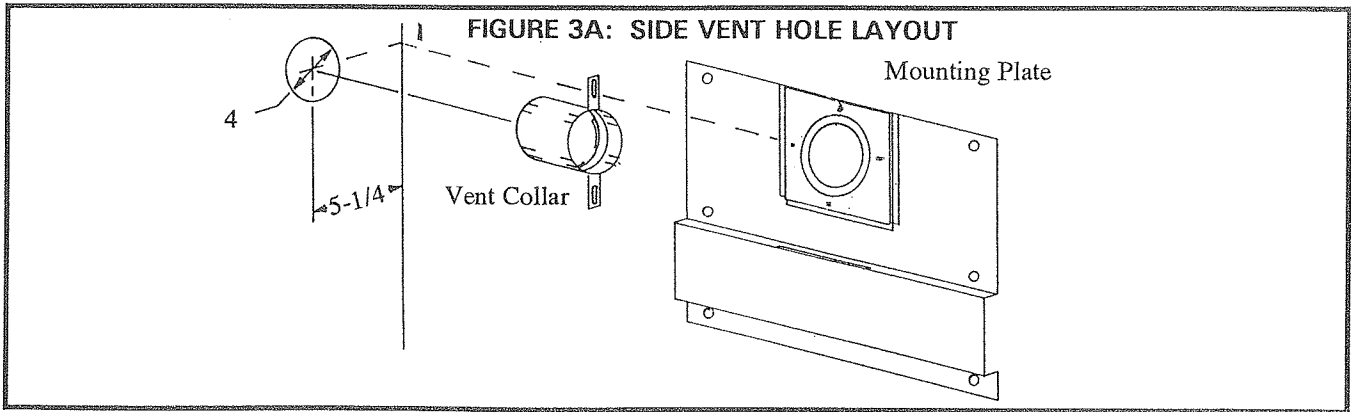

WARNING

This boiler is supplied with a factory designed vent system intended **ONLY** for use with itself. Do not attempt to connect other PF series boilers or any other appliances to this vent system. Do not attempt to use any vent components not specified by Crown Boiler Co. for use on this boiler. If you are removing an old appliance connected to a common venting system on this job site, see Appendix A.

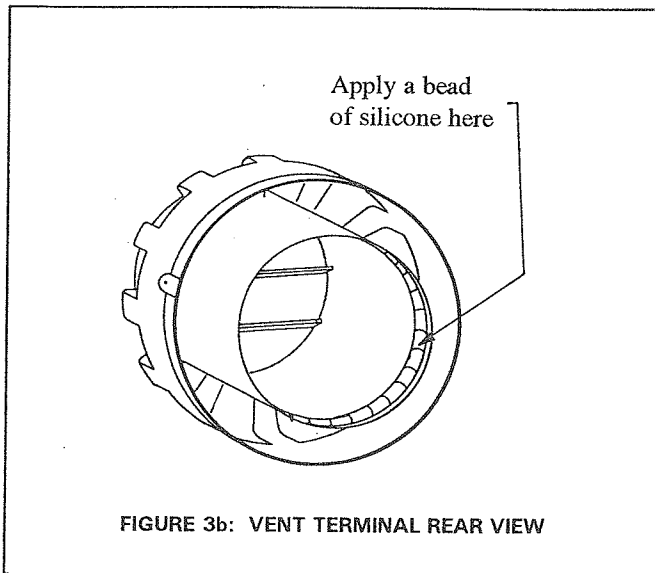

- b) Using the tape provided, wrap the vent tube where it could come in contact with mortar.
- c) Apply a bead of silicone (provided by Crown) around the I.D. of the vent terminal where it fits over the inner vent tube (Fig. 3b). The vent terminal flue exhaust grill is designed to discharge flue gases at an angle. Slip the vent terminal onto the vent tube and rotate it to a position so that the flue gases will be directed away from any inside corners, overhangs, or other obstructions near the terminal after it is installed. Secure the vent terminal to the vent tube with the screws provided. **MAKE SURE THAT A GOOD SEAL EXISTS BETWEEN THE VENT TERMINAL AND INNER VENT TUBE BEFORE PROCEEDING FURTHER.**

- d) **Rear Vented Boilers Only** -Install the rubber gasket provided in the boiler mounting plate. Push the vent tube through this gasket and through the wall until the flange is against the mounting plate.
- d) **Side Vented Boilers Only** -Install the vent collar provided in the vent tube opening. Drill holes through the mounting ears and attach with the screws provided. Push vent through wall until vent terminal is through sealing collar. Bend the 4 tabs on the flue sealing collar inwards to retain the rope sealing ring. Push the vent through the wall until the flange is clear of the mounting plate.

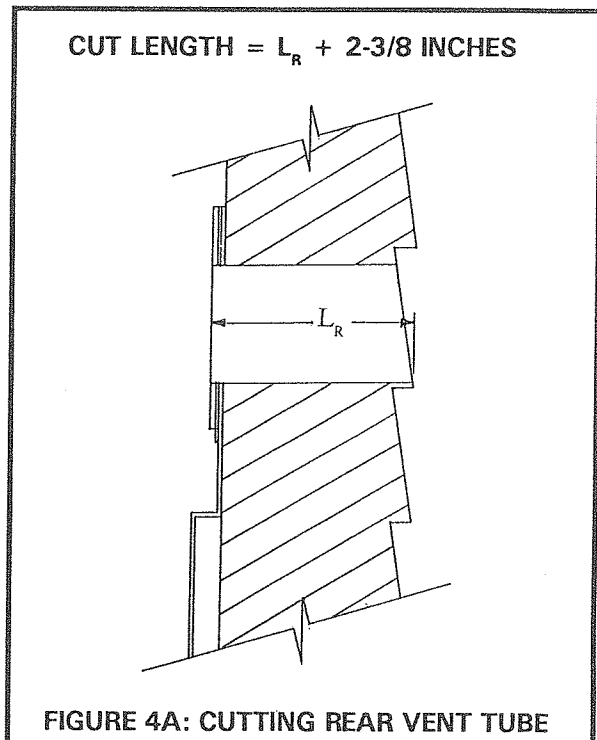

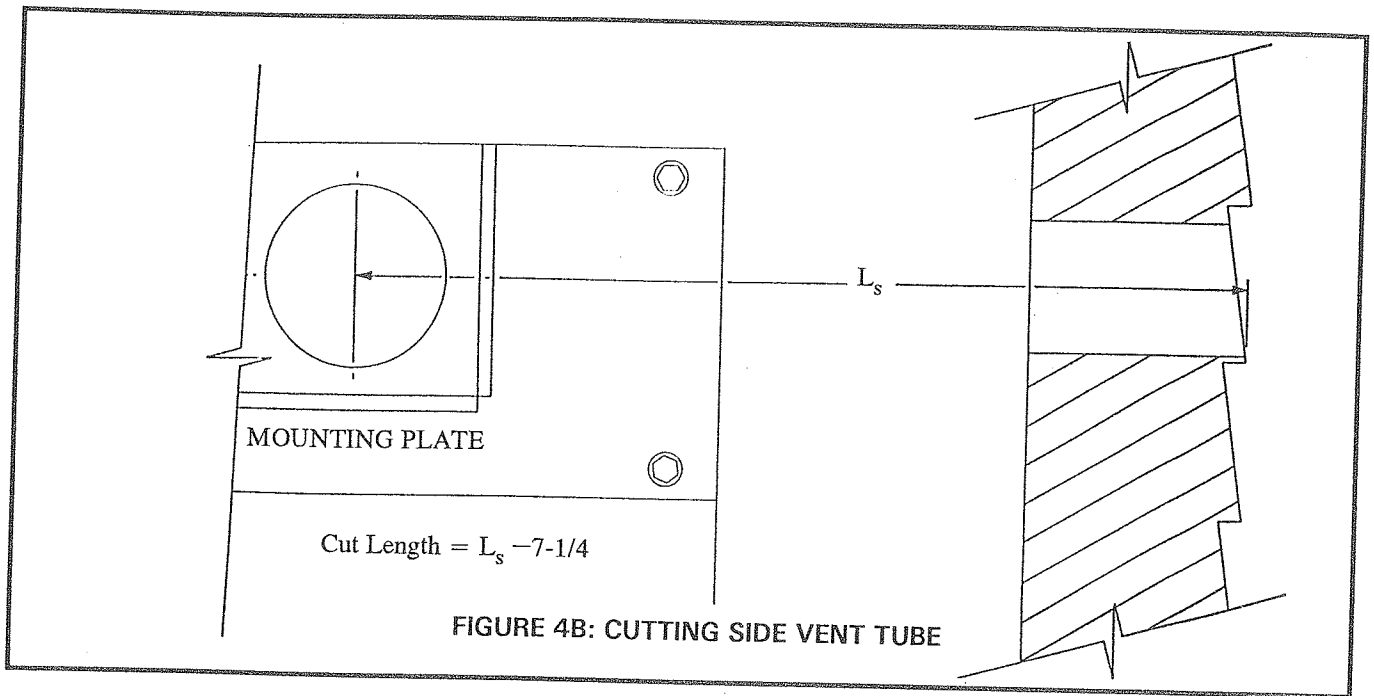

4. Boiler preparation

- a) Move vent cover plate to match vent tube position (right or rear). Place vent cover removed over remaining opening. This step is not necessary for a left side vented boiler as cover plates are correctly configured for this as shipped. **Note:** Flue elbow may be temporarily removed to gain access to the vent cover wing nuts.

- b) Install 3/4 side outlet tee provided on supply pipe with the run of the tee in the vertical. Install the relief valve provided on the top tapping (Fig. 5).

5) Hanging the boiler

WARNING

This boiler is heavy. Two people are required to safely lift boiler onto mounting plate.

- a) Lean boiler against wall directly under mounting bracket. Two people are required to lift unit.
- b) Lift boiler and place hook on the rear of the boiler into the slot on the wall mounting plate (Fig. 6).
- c) Remove control cover. Center boiler hook in slot in the sideways direction. Check that boiler is plumb and attach boiler to wall with #10 x 1-1/4" screws and 3/16" washers through lower mounting feet (Fig. 7).

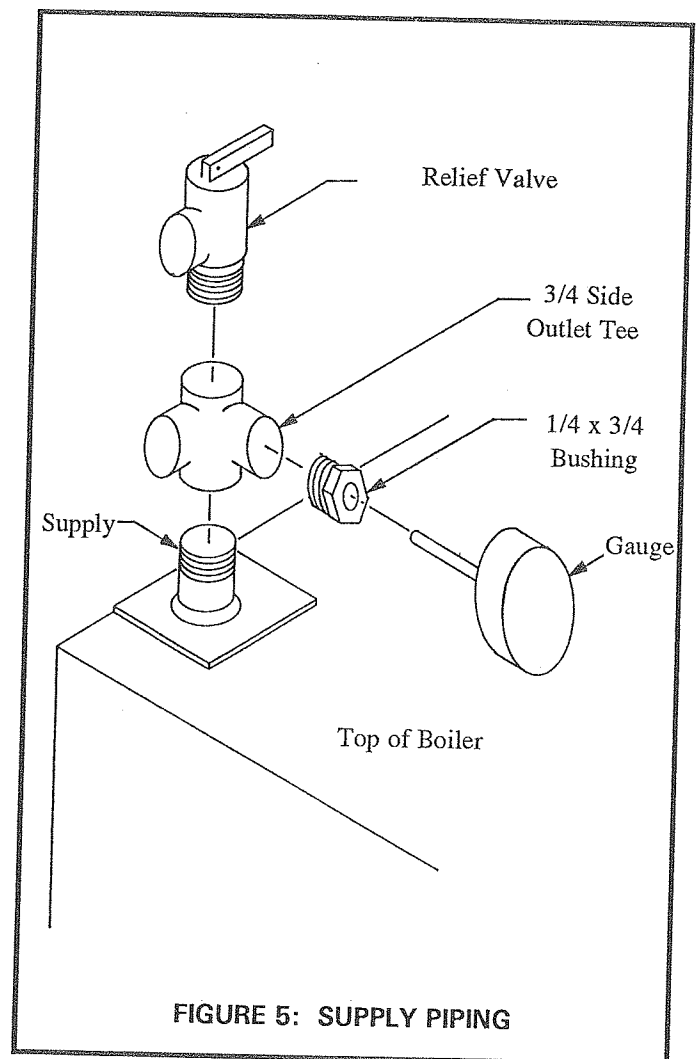

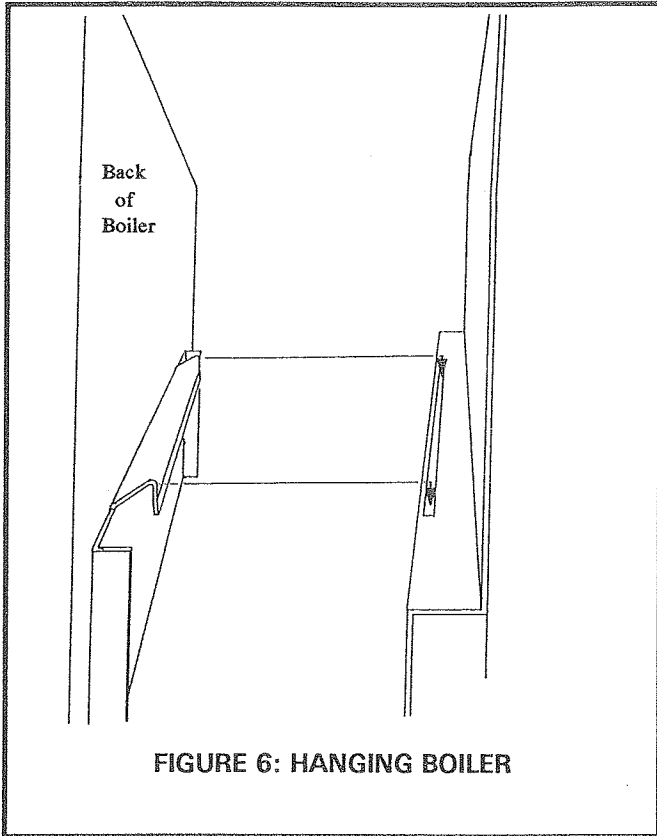

FIGURE 6: HANGING BOILER

IMPORTANT

Before mounting the fan assembly and casing door, complete all water piping in accordance with the following section, pressurize the system, and check the system for leaks. Pay careful attention to the following areas as they will not be visible later on:

- a) Supply and return joints inside casing (by the flue collector)
- b) 3/4" drain nipple and cap (lower left corner of heat exchanger)
- c) Clean out covers on heat exchanger.

Fix any leaks found in these areas before attempting to operate boiler.

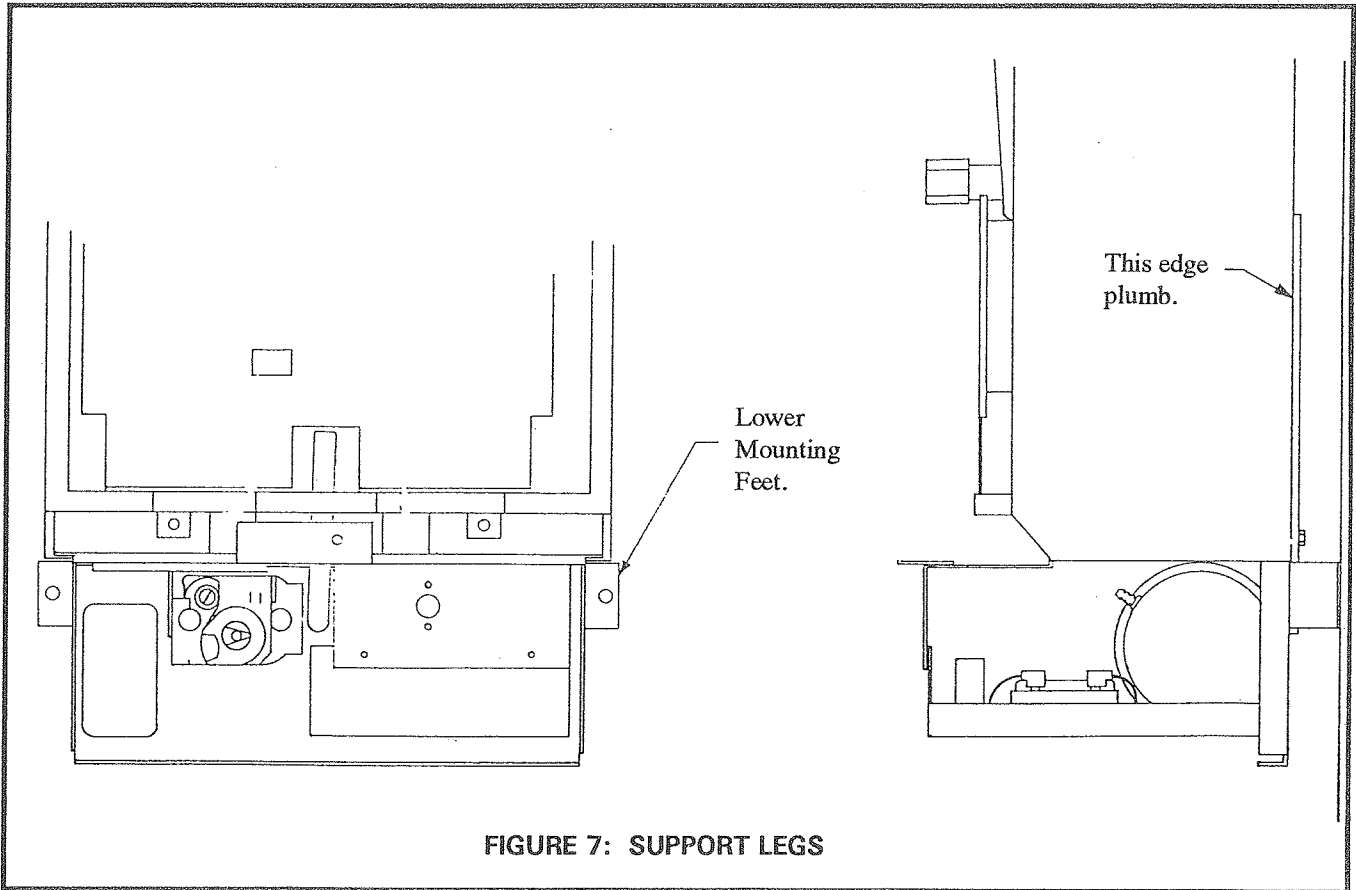

FIGURE 7: SUPPORT LEGS

VII. WATER SYSTEM PIPING

NOTE

Although the threaded water piping supplied with this boiler is 3/4" NPT, installations using PF82's may require some 1" piping in order to get adequate water flow through the system. For this reason 3/4" NPT x 1" female sweat adapters are provided and should be installed as close to the 3/4" boiler piping as possible if 1" piping is required. For more information on proper pipe sizing consult Hydronics Institute publication #200.

- 1) For safe, reliable operation, the system this boiler is connected to must have the following components.
 - ✓ Temperature- pressure gauge (Provided by Crown)
 - ✓ Properly sized circulator
 - ✓ Properly sized expansion tank
 - ✓ Connection to fresh water for filling (automatic fill preferred)
 - ✓ Relief valve (provided by Crown and installed in Part IV, step F part 2).
 - ✓ One automatic air vent and sufficient manual vents to purge all air from the system. (Automatic vent supplied by Crown)

Some of these components are available in a package designed for use with this boiler. See your Crown dealer for specifications.

- 2) This boiler is supplied with an automatic air vent, 3/4" Tee, and a 3/4" x 1/8" bushing so that the air vent may be mounted at the boiler return. If this is done, the Tee is screwed on to the male connection on the right top of the boiler with its run in the vertical. The bushing and air vent are then installed on the top of this Tee and the return connection is made on the side of this Tee.

If you are installing the boiler with a low water cut-off on the supply as shown in Fig. 8b, install an air vent by the low water cut-off regardless of whether one is installed on the return. **AT LEAST ONE AUTOMATIC AIR VENT MUST BE PROVIDED ON EITHER THE SUPPLY OR RETURN ON THE TOP OF THIS BOILER.**

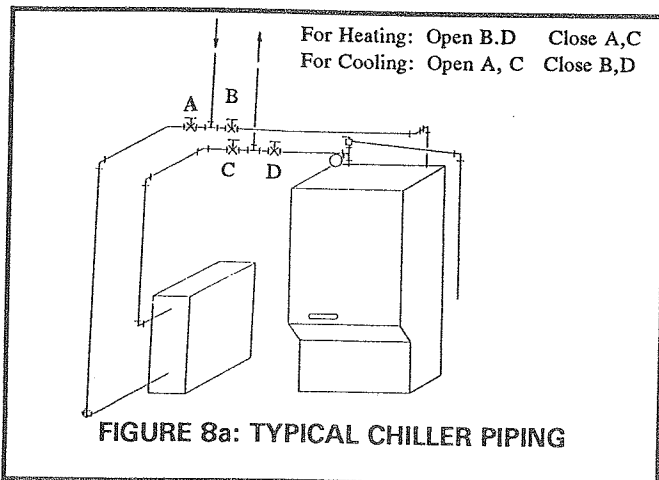

- 3) If the boiler is to be installed above the radiation, a low-water cut-off must be installed in the system. The best location for this is the supply piping above the boiler. Locate this low water cut-off and an automatic air vent in a cross as shown in Fig. 8b.
- 4) This boiler is designed for use in a closed system. Excessive feeding of fresh water through boiler will destroy the heat exchanger.
- 5) If boiler is to be used in conjunction with a water chiller, a means must be provided to prevent the chilled medium from entering the boiler. Install shut-off valves as shown in Figure 8a.
- 6) If the boiler is to be connected to heating coils located in air handling units where they may be exposed to refrigerated air circulation, flow control valves or other automatic means must be used to prevent gravity circulation during the cooling cycle.
- 7) If any part of the heating system is subject to freezing temperatures, antifreeze should be used to protect the system from damage. A non toxic antifreeze must be used. Consult antifreeze manufacturer for proper ratio of antifreeze to water.
- 8) Pipe relief valve to nearby drain or other location where hot water discharge will not cause injury or damage. Leave a 6" inch gap between the relief valve pipe termination and the drain pipe or closest obstruction. Termination of relief valve must be unthreaded. **Do not pipe relief valve pipe to outdoors or other potentially freezing location.**

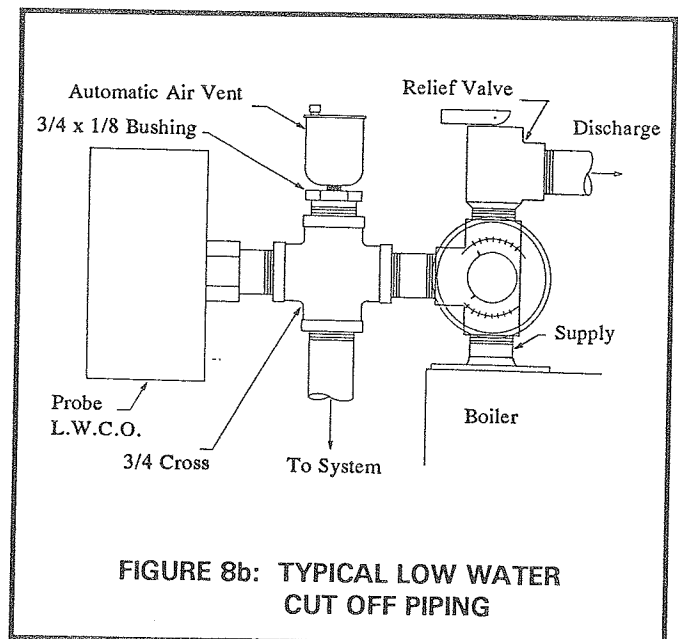

- 9) **Zoning-** Many different ways of zoning systems exist and the details of such are beyond the scope of this manual. The following points should however be kept in mind.

✓ If this boiler is to be used with an indirect water heater it may be desirable to install the boiler with a 3 way zone valve so that all boiler water is diverted to the water heater during a call for domestic water. This "priority zoning" can also be done using 2 way zone valves, or circulators, and a SPDT switching system.

✓ If circulators are used for zoning, a flow check should be installed on the opposite end of the zone from the circulator to prevent gravity, or other unwanted circulation.

VIII. COMPLETING BOILER ASSEMBLY

- 1) Slide vent tube towards boiler and engage the flange studs in the casing.
- 2) Secure vent tube to casing with the four 5mm wing nuts provided.
- 3) **Rear Vent Only** - If not already done, remove the four wing nuts securing the flue elbow to the flue collector, leaving the silicone pressure tubes attached. Insert the flue elbow into the inner vent tube and reinstall wing nuts. Using the silicone supplied, carefully seal the joint between the flue elbow and the inner vent tube.
- 3) **Side Vent Only** - If not already done, remove the four wing nuts securing the flue elbow to the flue collector, leaving the silicone pressure tubes attached. Insert the flue elbow into the aluminum flue elbow extension provided in the parts bag. Insert the flue elbow and extension into the inner vent tube and reinstall wing nuts. Using the silicone supplied, carefully seal the joints between the flue elbow, elbow extension, and inner vent tube.

NOTE

It is important NOT to apply the silicone to the above mentioned joints until AFTER the elbow and extension (if used) are installed. If silicone is applied to the male side of these joints prior to inserting them, it will be extremely difficult to break the joints if the flue collector must be removed for servicing.

- 4) Mount fan assembly to boiler with the seven 5mm screws provided. Plug fan wires into fan plug on boiler (Fig. 11).
- 5) Install casing door, making sure that a good seal exists around the joint between this door and the casing.
- 6) Seal vent terminal to outside wall with 400 F. silicone
- 7) Install wall plate provided to cover any damage to the wall around the vent terminal.

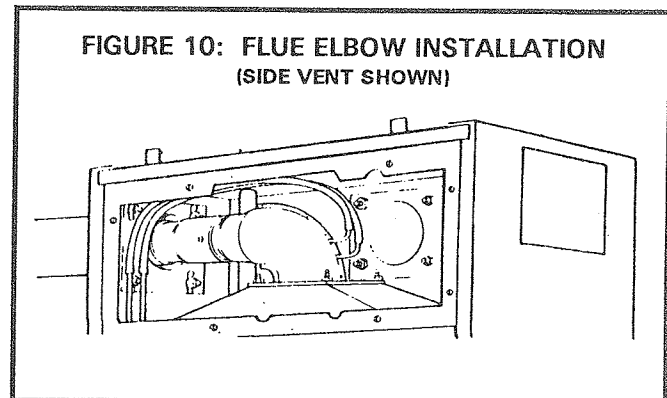
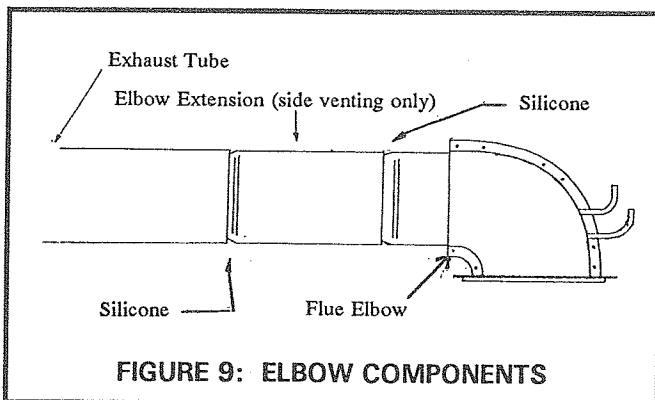
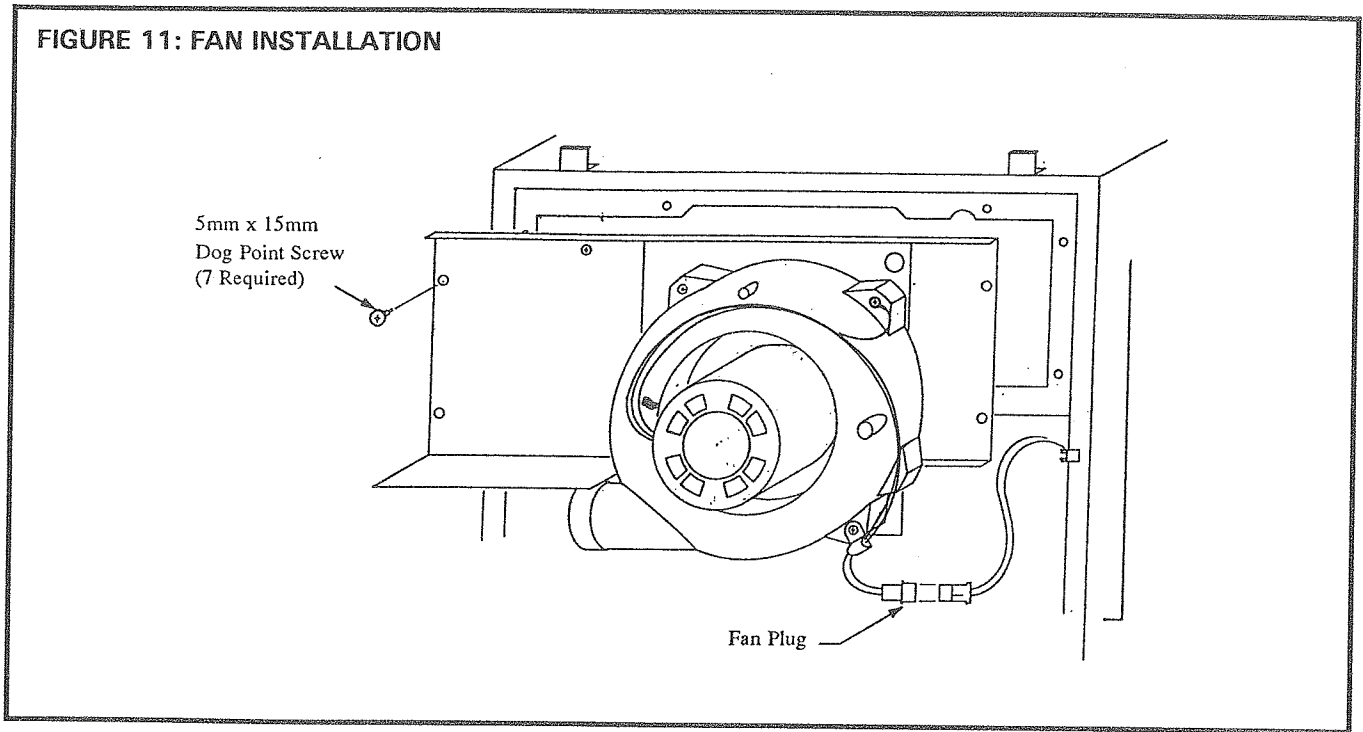

FIGURE 11: FAN INSTALLATION



IX. GAS PIPING

NOTE

It is easier to make the electrical connections in the junction box prior to installing gas piping.

1) Observe the following when making gas connection.

✓ Use only ungalvanized steel pipe and black malleable iron fittings unless other materials are permitted by the authority having jurisdiction over local gas piping.

✓ Use a pipe dope suitable for use with Natural & LP gas regardless of the fuel used. Apply dope to male threads only, keeping first 3 threads free of dope.

✓ Use only ground joint unions.

✓ Install a drip leg to prevent sediment from reaching the gas valve (Fig. 12).

✓ Install a manual main shut-off valve. Where codes require place this outside the control cover (Fig. 12).

✓ Install a union in an accessible location so that gas train may be removed from boiler if needed for servicing (Fig. 12).

✓ Make sure gas piping is properly sized for the installation. Consult authority having jurisdiction over this (usually the gas company) or in the absence of such an authority, ASNI-Z223.1-1988.

WARNING
Do not use an open flame to check for leaks.

2) **Testing gas piping**

a) Gas piping must be tested for leaks immediately after turning on gas to the boiler. To do this spray the piping with a soap suds solution. Forming bubbles indicates a leak. Correct any leak found, no matter small, at once.

b) The boiler and its individual shut-off valve must be disconnected from the gas supply piping system during any pressure testing of that system at test pressures greater than 1/2 psi.

c) The individual shut-off valve of the boiler must be closed during any pressure test of the gas supply piping system at pressures less than or equal to 1/2 psi.

FIGURE 12: TYPICAL GAS PIPING

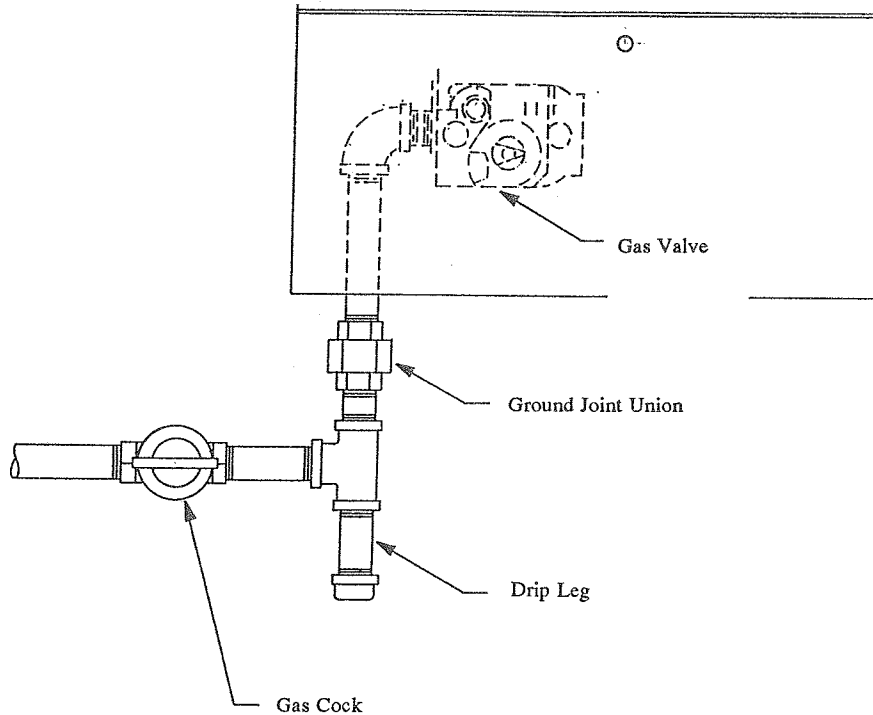

X. ELECTRICAL WIRING

1) Wiring must be in accordance with all codes. In the absence of any codes, boiler must be wired and grounded in accordance with the National Electric code (ANSI/NFPA 70-1990).

3) Boiler system must be connected to its own 15 amp circuit. A remote emergency shut-off switch should be installed ahead of all other boiler controls. If the boiler is in a closet, install the emergency switch just outside the closet.

2) **High voltage connections** - Four high voltage pigtails are located in the utility box to the left of the gas valve. These are:

- Black- "Hot" to boiler
- White- "Neutral" for boiler and circulator
- Red- "Hot" for circulator
- Green- Equipment ground

Bring a cable or cables into the utility box along the gas line so that they will be in the control cover's "U" slot when the cover is installed. Make connections inside utility box and install utility box cover.

If a circulator with an amp draw of more than 12 amps is used a contactor is required.

- 4) Low voltage connections - Remove the two 8-32 x 1/2 screws from the control tray and swing it down (Fig. 13a, 13b). The low voltage terminal strip is in the forward left corner. Terminals are as follows:

T,T- Connect to thermostat, zone valve, end switch, or other dry contacts which are intended to start the boiler upon closing (Fig. 14b).

- 1,2- Auxiliary 24VAC power source for 3 way motorized zone valve or other device requiring less than 15.6 VA of power.

IMPORTANT

If terminals 1 & 2 are connected to a device drawing more than 0.65 AMPS the boiler transformer may be destroyed.

Make 24 volt connections by running low voltage wiring from the low voltage terminal strip through the clips on the left edge of the control tray. These wires can then be routed out of the boiler either along the gas pipe or through metal conduit installed in the 7/8" knock-out to the left of the control tray.

- 5) Zone wiring- Fig. 14c, d, and e show common zone wiring for 3 way domestic water zone valves, 2 way zone valves, and circulator zoning respectively.

FIGURE 13A: GENERAL CONTROL LAY-OUT

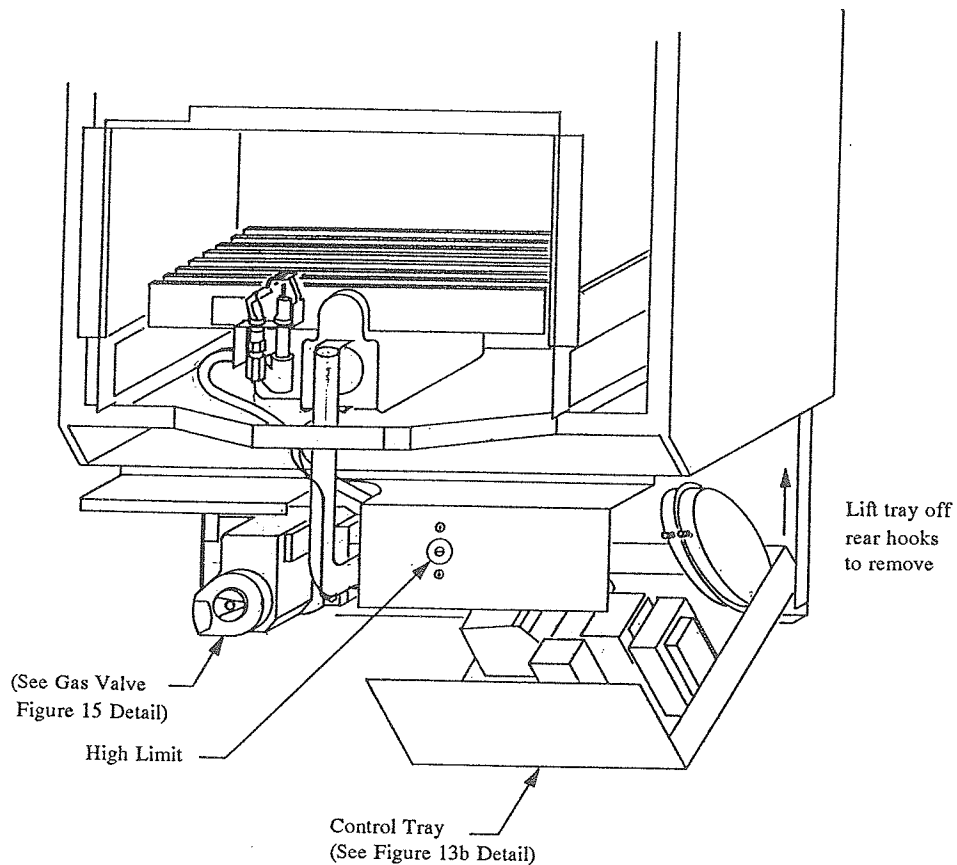

FIGURE 13B: CONTROL TRAY TOP VIEW

Wiring Harnesses omitted for clarity

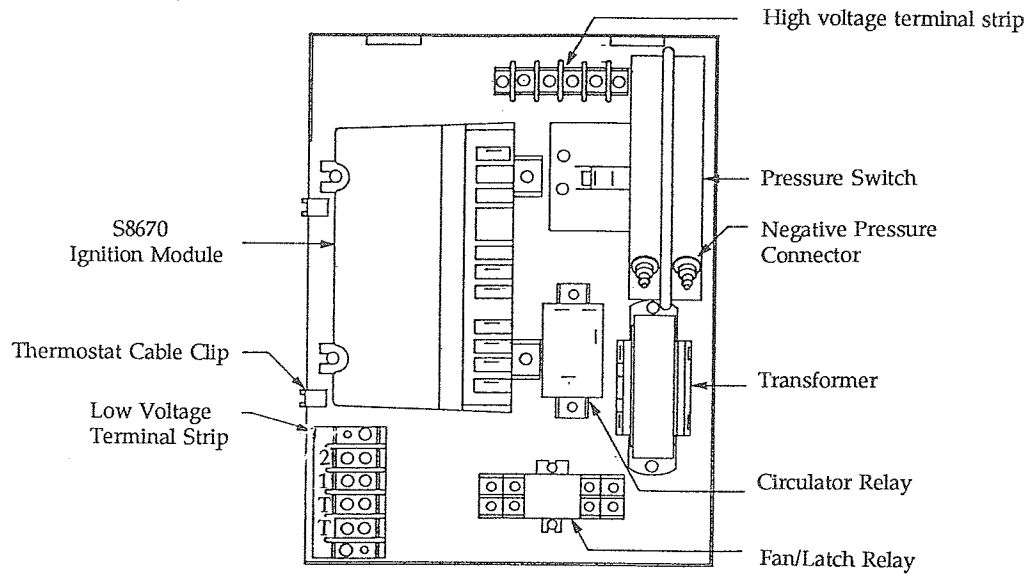

FIGURE 14A: 115 VOLT WIRING - FOR USE WITH FIGURES 14B, C, D

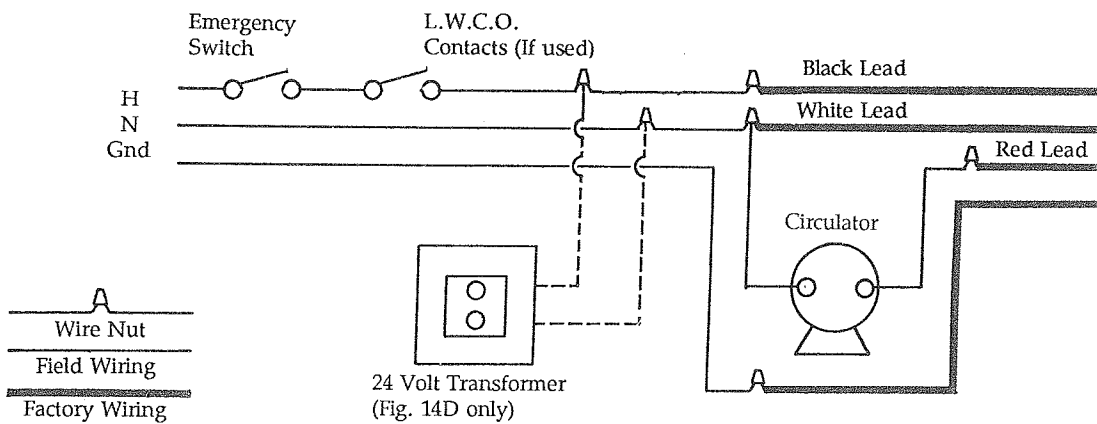

FIGURE 14B: 24 VOLT WIRING - SINGLE ZONE

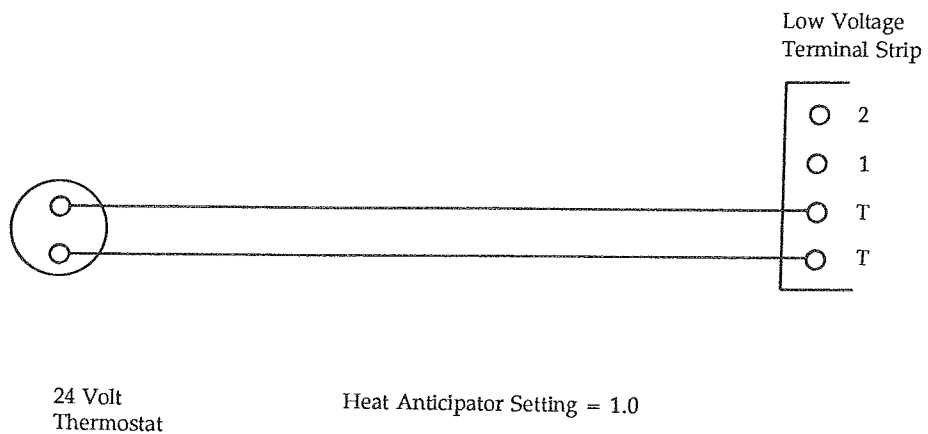

FIGURE 14C: 24 VOLT WIRING - PRIORITY ZONING OF AN INDIRECT WATER HEATER WITH A 3 WAY ZONE VALVE

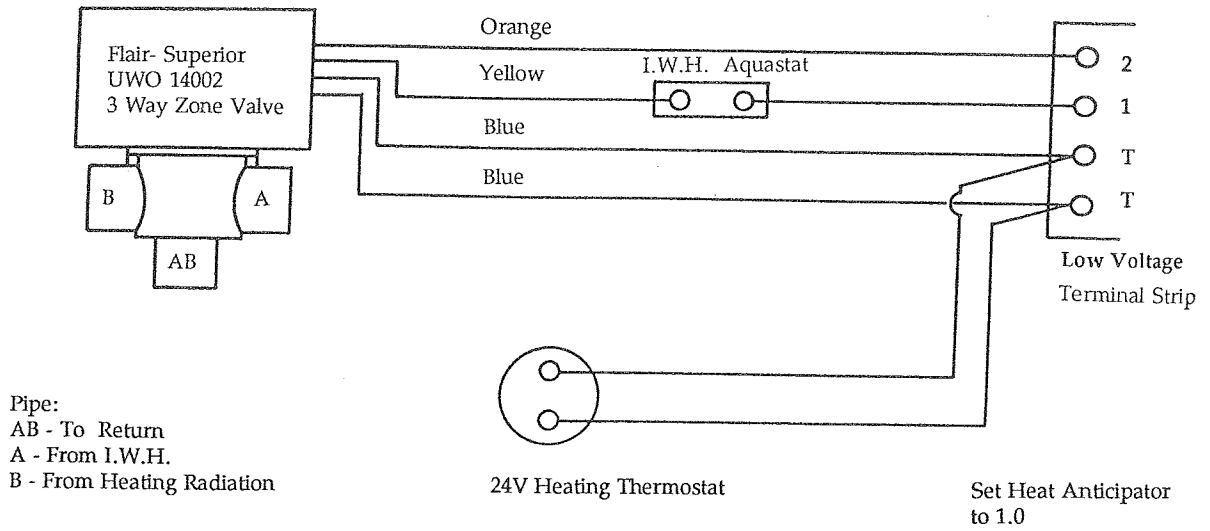

FIGURE 14D: 24 VOLT WIRING - ZONING WITH HONEYWELL V8043F ZONE VALVES

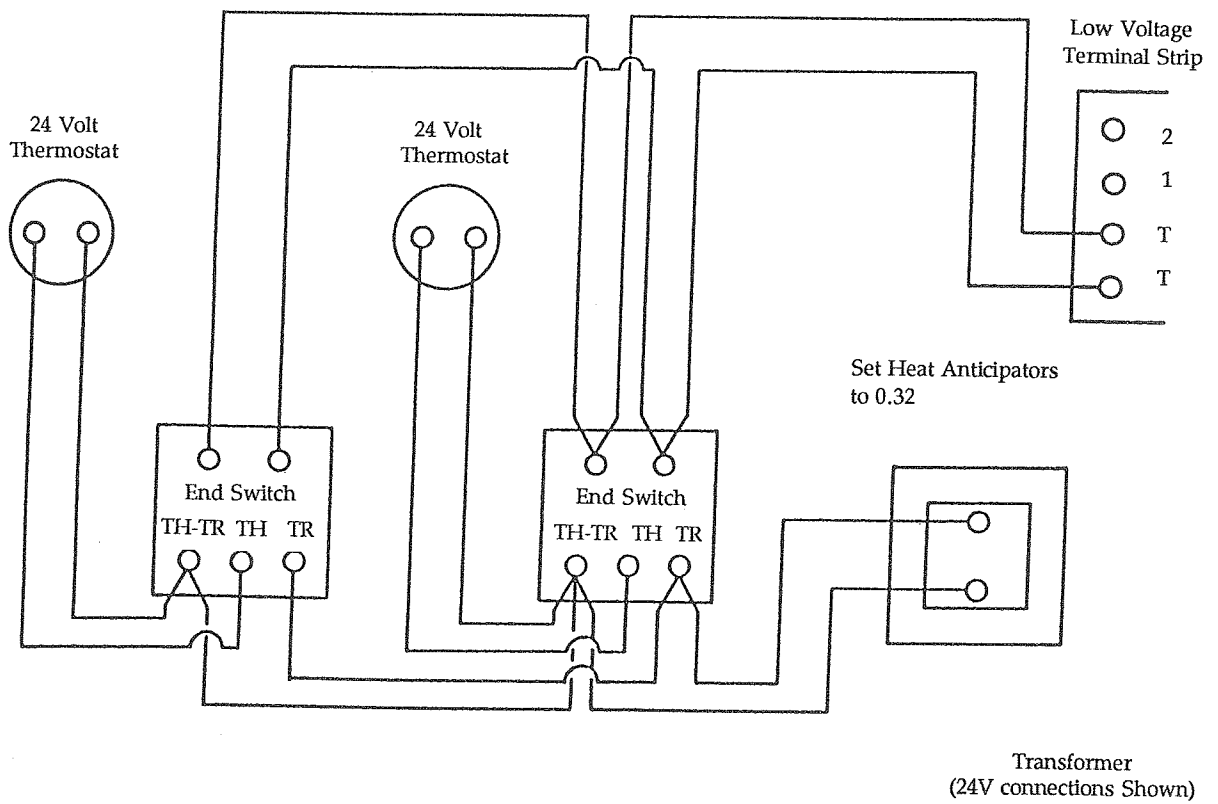
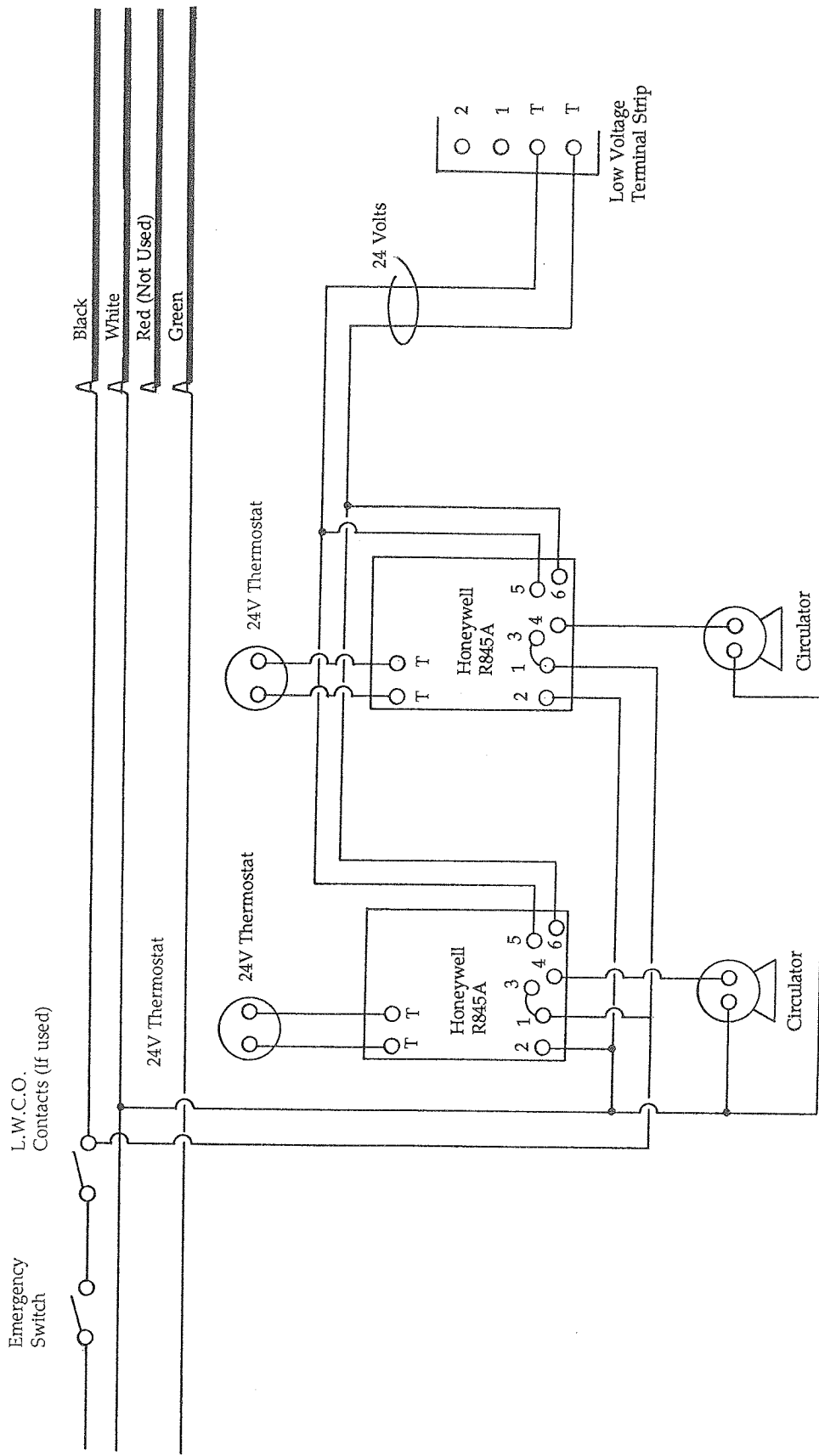

FIGURE 14E: 24 AND 115 VOLT WIRING - CIRCULATOR ZONING
 (All Wiring 115 Volts Unless Otherwise Specified)



Set Heat Anticipators to 0.40

XI. START-UP AND CHECK-OUT

- 1) Fill the boiler system with water and purge of all air. Pressurize to desired operating pressure (typically 15psi).
- 2) Fire boiler: Turn on electrical power from remote disconnect switch.

WARNING

Never attempt to fill a hot empty boiler.

NOTE

Safe lighting and other performance criteria were met with gas manifold and control assembly provided on this boiler when the boiler underwent the tests specified in ANSI Z21, 13b-1991.

FOR YOUR SAFETY READ BEFORE OPERATING

WARNING: If you do not follow these instructions exactly, a fire or explosion may result causing property damage, personal injury or loss of life.

- A. This appliance is equipped with an ignition device which automatically lights the pilot. Do not try to light the pilot by hand.
 - If you cannot reach your gas supplier, call the fire department.
 - B. BEFORE OPERATING smell all around the appliance area for gas. Be sure to smell next to the floor because some gas is heavier than air and will settle on the floor.
 - C. Use only your hand to push in or turn the gas control knob. Never use tools. If the knob will not push in or turn by hand, don't try to repair it, call a qualified service technician. Force or attempted repair may result in a fire or explosion.
 - D. Do not use this appliance if any part has been under water. Immediately call a qualified service technician to inspect the appliance and to replace any part of the control system and any gas control which has been under water.
- WHAT TO DO IF YOU SMELL GAS**
- Do not try to light any appliance.
 - Do not touch any electric switch; do not use any phone in your building.
 - Immediately call your gas supplier from a neighbor's phone. Follow the gas supplier's instructions.

OPERATING INSTRUCTIONS

1. STOP! Read the safety information above on this label.
2. Set the thermostat to lowest setting.
3. Turn off all electric power to the appliance.
4. This appliance is equipped with an ignition device which automatically lights the pilot. Do not try to light the pilot by hand.
5. Remove control access panel.
6. Push in gas control knob slightly and turn clockwise to "OFF."
NOTE: Knob cannot be turned to "OFF" unless knob is pushed in slightly. Do not force.
7. Wait five (5) minutes to clear out any gas. If you then smell gas, STOP! Follow "B" in the safety information above on this label. If you don't smell gas, go to next step.
8. Turn gas control knob counterclockwise to "ON"
9. Replace control access panel.
10. Turn on all electric power to the appliance.
11. Set thermostat to desired setting.
12. If the appliance will not operate, follow the instructions "To Turn Off Gas To Appliance" and call your service technician or gas supplier.

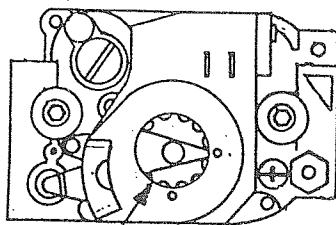

Gas Control Knob
Shown in "ON"
Position

3) Check-out

- a) **Ignition system safety check-** Fire boiler and carefully disconnect ignition cable from the S8670E. Main and burner flame should immediately extinguish. If it does not, consult the gas utility or Crown representative. Do not leave in operation.

If main flame extinguishes, turn off power to the boiler and reconnect spark cable. Boiler may then be restarted

- b) **High limit check-** Set the high limit to the desired setting (180° F is typical for baseboard or standing radiation). Raise or temporarily jump the thermostat so as to run the boiler until the water temperature reaches the limit setting. At the water temperature $\pm 10^\circ$ F the burners should shut down and the circulator continue to operate.
- c) **Thermostat check and adjustment -** Lower thermostat to point shown on thermostat thermometer and make sure that the burners and circulator shut-off at approximately this setting. Set thermostat heat anticipator. On a zoned system this step must be done for each thermostat.
- d) **Main burner check-out-** Main burner flame should be mostly blue in color and well defined (Fig. 17). No yellow should be present although orange

flecks may intermittently appear. If yellow is present in the flame:

- ✓ Check the manifold pressure at the gas valve. This should be:

4.0 in w.c. for Natural gas
8.0 in w.c. for LP Gas

- ✓ Check gas orifice size against parts list in the back of this manual. Check for burrs or score marks in orifice opening.

If the boiler is natural gas fired, the input may alternately be checked by clocking the gas meter.

The input is then approximately:

$$\text{BTU/hr Input} = \frac{(1000 \text{ BTU/ft}^3) \times (\# \text{ Cu. ft clocked}) \times (3600 \text{ S/hr.})}{(\# \text{ Seconds clocked})}$$

- ✓ Check the orifice and burner venturi for any foreign matter.
- ✓ Check to make sure that the flue orifice and air intake orifice are of the correct size.
- ✓ Check that there is no recirculation of flue gases into combustion air system.
- ✓ Check casing for combustion air leakage.

FIGURE 15: GAS VALVE

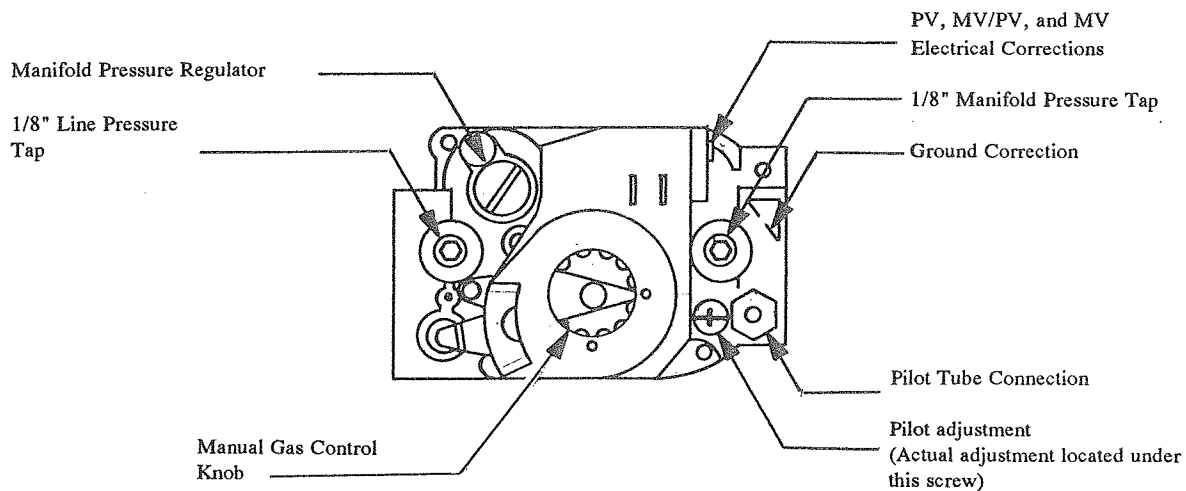

TO TURN OFF GAS TO APPLIANCE

1. Set the thermostat to lowest setting.
2. Turn off all electric power to the appliance if service is to be performed.
3. Remove control access panel.
4. Push in gas control knob slightly and turn clockwise  to "OFF." Do not force.
5. Replace control access panel

- e) **Pilot check-out-** Pilot should be blue, stable, and completely cover the gap between the electrode and grounding strap (Fig. 18). If necessary, it may be adjusted by removing the cover screw shown in Fig. 15. Using a 1/8" flat bladed screw driver, turn the pilot adjusting screw clockwise to lower the pilot and counter clockwise to raise it.
- f) **Casing seal check –** With the boiler operating run your hand around the casing door joint and all other joints and seals to make sure no air is leaking from these areas.
- g) **Low Water Cut-off Check-out –** Check the low water cut off for proper operation at the intervals specified by the low water cut-off manufacturer. Consult the low water cut-off manufacturer's instructions for the proper manner in which to do this.

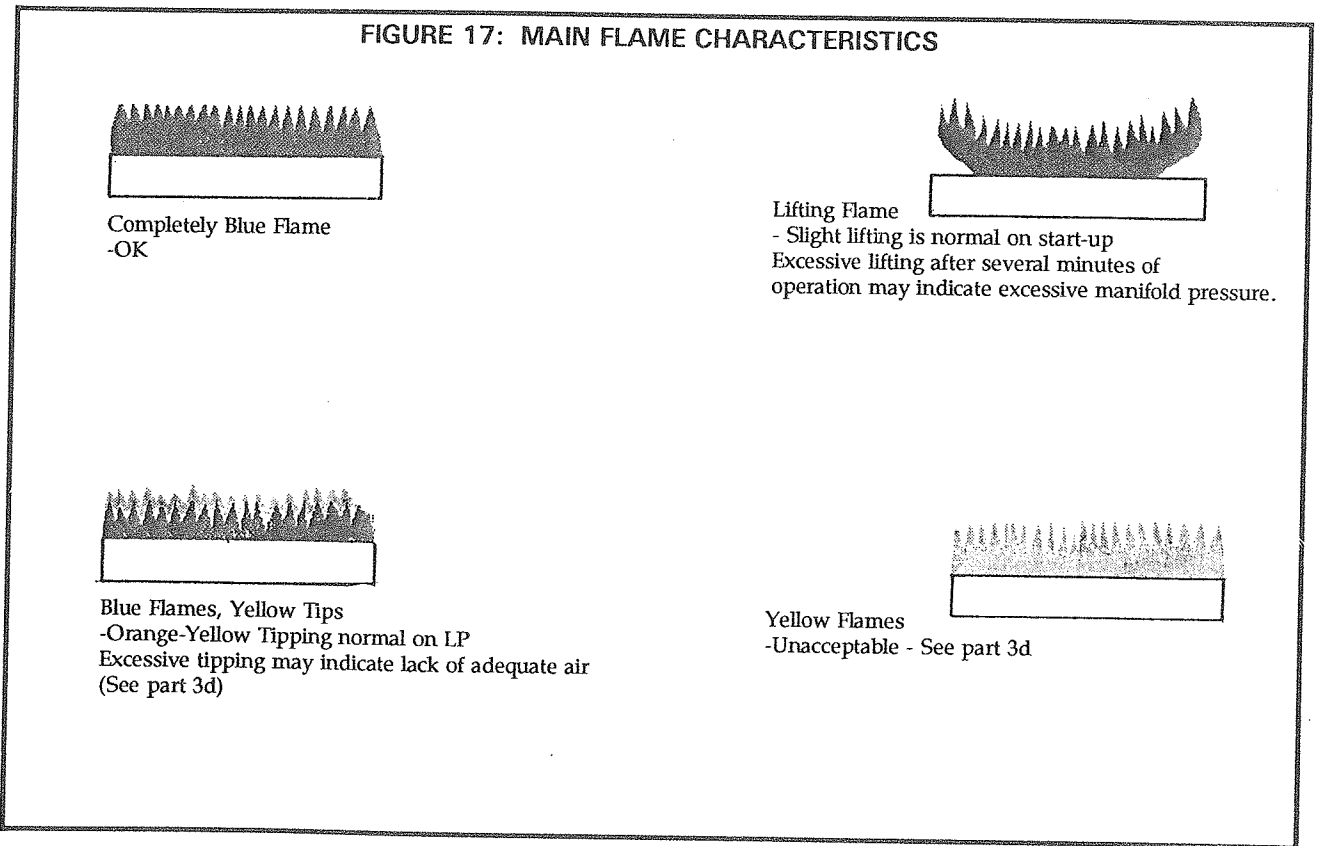
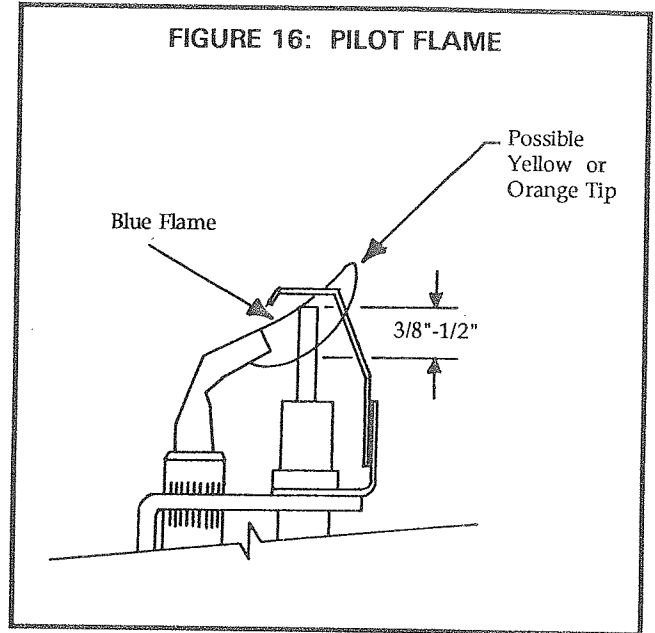

XII. MAINTENANCE

In order to ensure safe reliable operation the following maintenance procedures should be performed by a qualified serviceman on an annual basis.

- 1) Check flue passages for cleanliness - Remove control cover, casing cover, fan assembly, and

fire door. Remove the flue elbow, flue collector, and baffles (if used). Place a light in the combustion chamber. Using a mirror (held at a 45° angle over the top of heat exchanger) examine the flue passages.

Remove any visible deposits from the flue ways with a small flue brush. In order to prevent such

deposits from falling onto burners place a piece of cardboard on top of burner assembly before brushing out flue collector.

WARNING

A rapid accumulation of soot in a gas boiler is indicative of a hazardous condition. The cause of such sooting should be located and corrected (See section X part 3d)

- 2) Shine a light down both the inlet and exhaust tubes (this may have to be done from the vent terminal end). Inspect both air intake and vent tubes for foreign objects or deterioration of tubes. Also inspect vent terminal for blockage. Clean and repair as necessary

After cleaning and inspecting heat exchanger and vent tubes, reassemble flue collector, flue elbow, and fan assembly, replacing any deteriorated gaskets.

- 3) Burner assembly should be inspected for foreign matter in the venturi and blade holes. Any such matter should be blown out with compressed air or vacuumed out. Once burner has been inspected the fire door may be reinstalled.
- 4) Fan motor is equipped with ball bearings, and should not be lubricated.
- 5) Reassemble casing cover, and control cover. Perform checks outlined in Section X.

XIII. TROUBLESHOOTING

- 1) Sequence of normal operation (Reference Fig. 18, Fig. 19).
 - a) Upon a call for heat thermostat terminals are made, energizing relay coil 1K. This closes contacts 1K1 which energizes circulator.
 - b) If the high limit contacts are made, and the C-NC pressure switch contacts are made, current flows through the 2K relay coil. This energizes the combustion fan via contacts 2K2 and simultaneously provides an alternate route to coil 2K around the C-NC contacts via contacts 2K1.

The purpose of this "latch" system is to provide a check, before attempting to start the burners, that the pressure switch is not stuck in the "pressure OK" position.

- c) The fan moves air through the boiler providing a pressure differential across the pressure sensing tubes in the flue elbow. If a pressure differential of at least a 1.74 ± 0.07 " w.c. is present, the C-NC contacts will break and the C-NO contacts will make. This energizes the Honeywell S8670-based intermittent ignition system.
- d) Upon begin energized, the S8670 module waits for a 30 second prepurge period to pass before attempting to light the pilot. At the end of this time, an ignition spark is started and 24VAC is applied to the pilot valve in the VR8204 (terminals PV-MV/PV).

- e) Upon establishment of a pilot flame, AC current coming up the ignition cable is rectified to a DC current by the pilot flame. This signal passes from the pilot grounding strap through the frame of the boiler to the ground screw in the utility box. It then travels to the "Grd" terminal on the S8670 via the green wire.

If the S8670 senses a current greater than $1.2\mu\text{A}$ DC it deenergizes the spark and energizes the main valve on the VR8204 gas valve (Terminals MV-MV/PV).

- f) If the pilot flame is not detected by the S8670 after a 90 second trial for ignition, it will deenergize the pilot valve and spark. It will then wait 5 minutes and try to establish pilot again. During this time the fan and circulator will continue to operate. If no pilot is ever detected, this cycle will continue indefinitely.
- g) After the main flame is established, the pilot will continue to burn. Both main and pilot flames will continue to burn until the thermostat or high limit opens. When either device opens the 2K relay coil is deenergized and the system returns to its original status.

If the high limit opens, only the 2K coil is opened. The 1K coil remains energized, keeping the circulator running until the call for heat is satisfied.

- 2) The following four pages contain a troubleshooting chart for use in locating and solving control problems. To use it do the following:
- a) Go to the start box on the next page and follow the instructions contained in that box.
 - b) Follow the line out of that box into diamond which asks "does the circulator start." If the circulator is operating follow the path leaving this diamond to the right (the "Y" for yes path). If it is not operating leave the diamond by the bottom ("N" for no path). Continue in this manner, following the boxed instructions and answering the questions in diamonds, until you come to a box with a list of possible causes denoted with asterisks (*). One of these causes is probably behind the problem being experienced.
 - c) If you rule out all the causes in a particular box, first retrace the path taken to get to this box and make sure that all questions have been accurately answered. If you arrive at the same box, check the wiring against the connections diagram in Fig. 19. If all wiring is in accordance with this diagram, contact a Crown representative for further assistance.

IMPORTANT

Although the causes listed in the boxes above are in no particular order, all controls are factory tested at least once in the assembly process and A DEFECTIVE CONTROL IS GENERALLY THE LEAST LIKELY CAUSE. If you suspect you have a defective control, double check your path through the troubleshooting chart before you replace it.

It is also important to remember that THE LIKELIHOOD OF COMING ACROSS TWO IDENTICAL DEFECTIVE CONTROLS IN A ROW IS ALMOST NIL. If this seems to be happening, chances are that either there is nothing wrong with the control or it is being damaged by some other problem (a short burning out a transformer, for example).

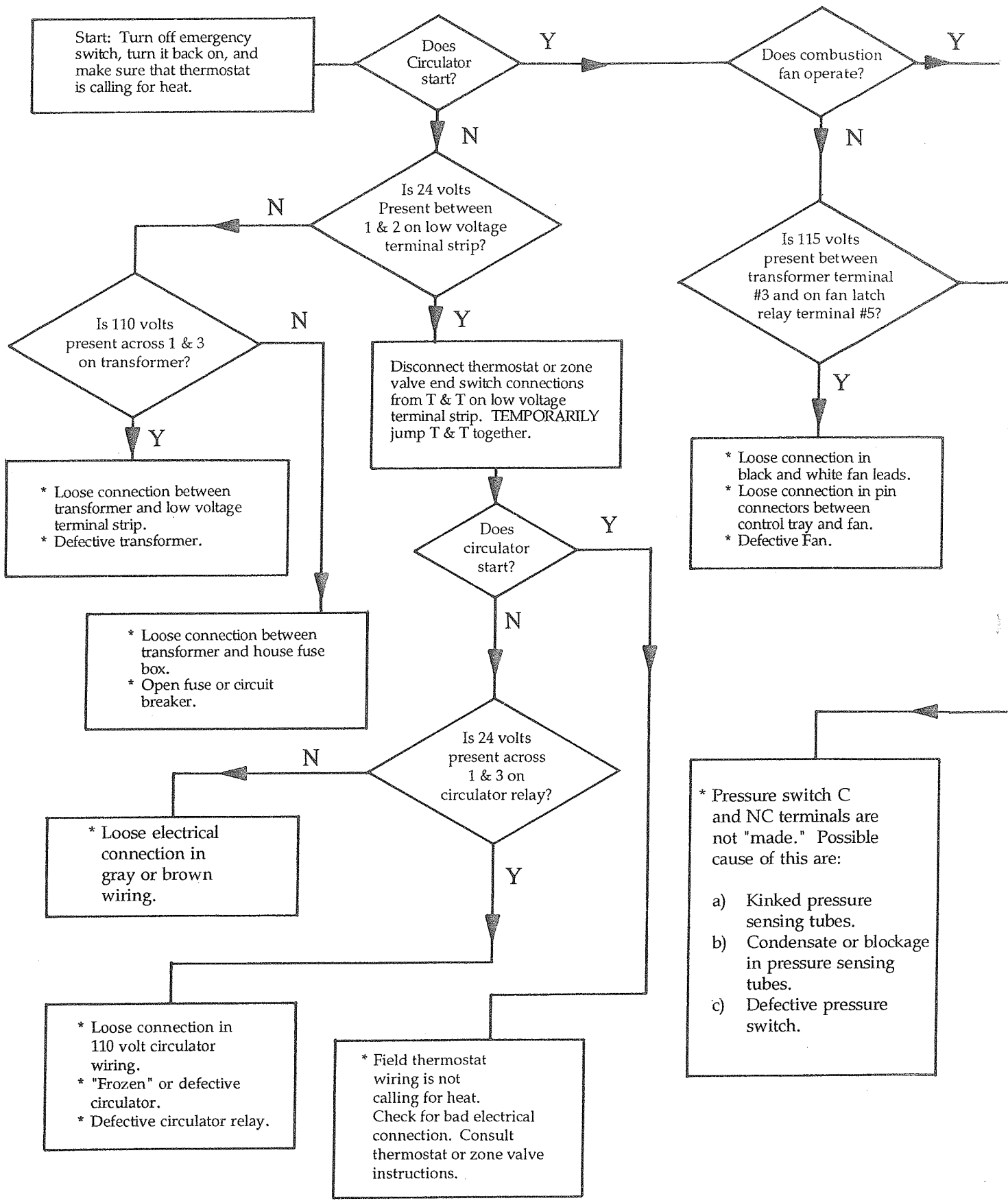

Wait 30 seconds. Note: If fan has been running more than 120 seconds continuously, the ignition system may be "locked out." If this has happened the ignition system will not "retry" until 5 minutes has passed from the time of lockout. Instead of waiting 5 minutes for this to occur, the ignition system may be "reset" by turning the 115 volt power to the boiler off and back on. The ignition spark should then start after approximately 30 seconds.

Does spark start at pilot? Y *Next Page*

Disconnect yellow and brown leads from S8670E. Connect a volt meter to these leads.

Is 24 volts present across these leads? N

- * Make sure that S8670E is not "locked out."
- * Inspect spark cable for poor connection or broken insulation.
- * Inspect pilot for cracked porcelain or misoriented electrode/grounding strap.
- * Defective S8670E.

Is 24 Volts present between terminals 13 and 8 on fan/latch relay? N

- * Loose connection in wiring or pin connector between high limit and control tray.
- * Boiler is off on high limit.
- * High limit is defective.

Is 24 Volts present between terminals 13 and 14 on fan/latch relay? Y

* Defective fan/latch relay or relay base.

Is at least 1.7" w.c. of pressure present between the pressure switch hose connections? Y

* Pressure sensing tubes are reversed. Make sure that the connections with red rings are connected together and go to the left ("red") pressure switch connection.
 * Defective pressure switch.

- * Pressure sensing tubes are reversed. Make sure that the connections with red rings are connected together and go to the left ("red") pressure switch connection.
- * Kinked pressure sensing tube.
- * Condensate or blockage in pressure sensing tubes.
- * Leaky pressure sensing tube.
- * Flue orifice missing.
- * Blockage in vent tubes.
- * Loose or missing casing door.
- * Sooted heat exchanger.
- * Damaged or missing gaskets under fan.
- * Defective fan.

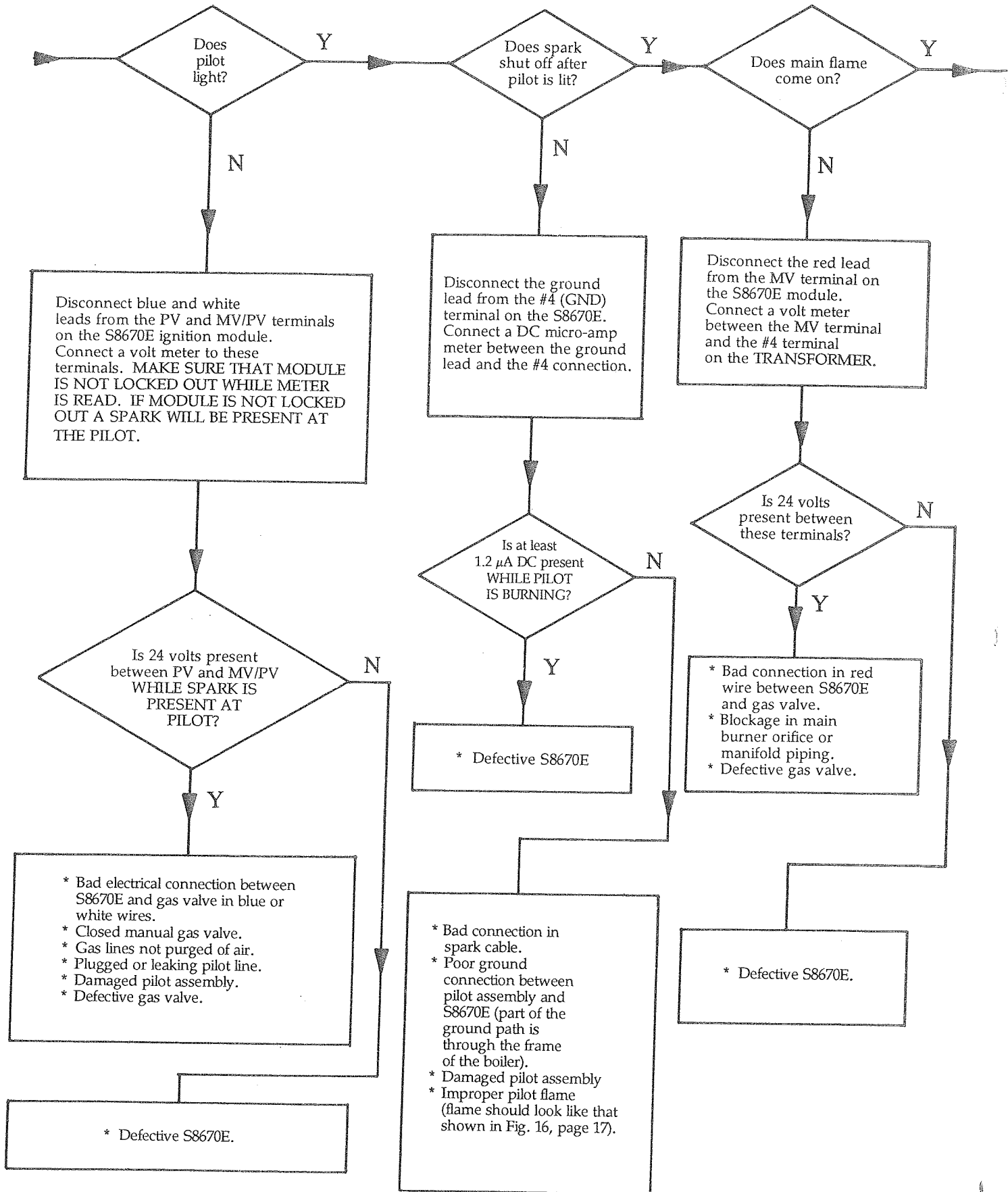

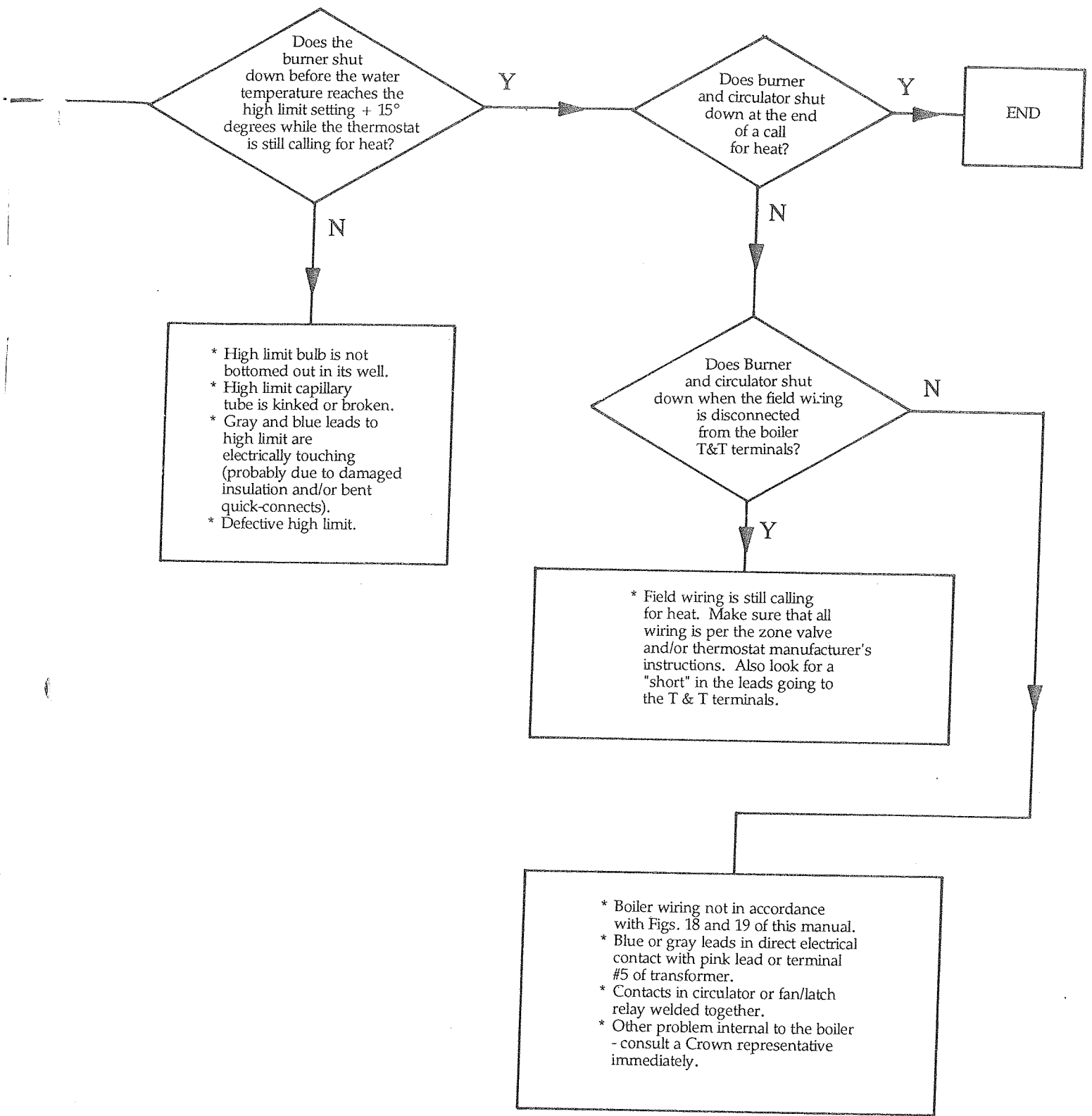
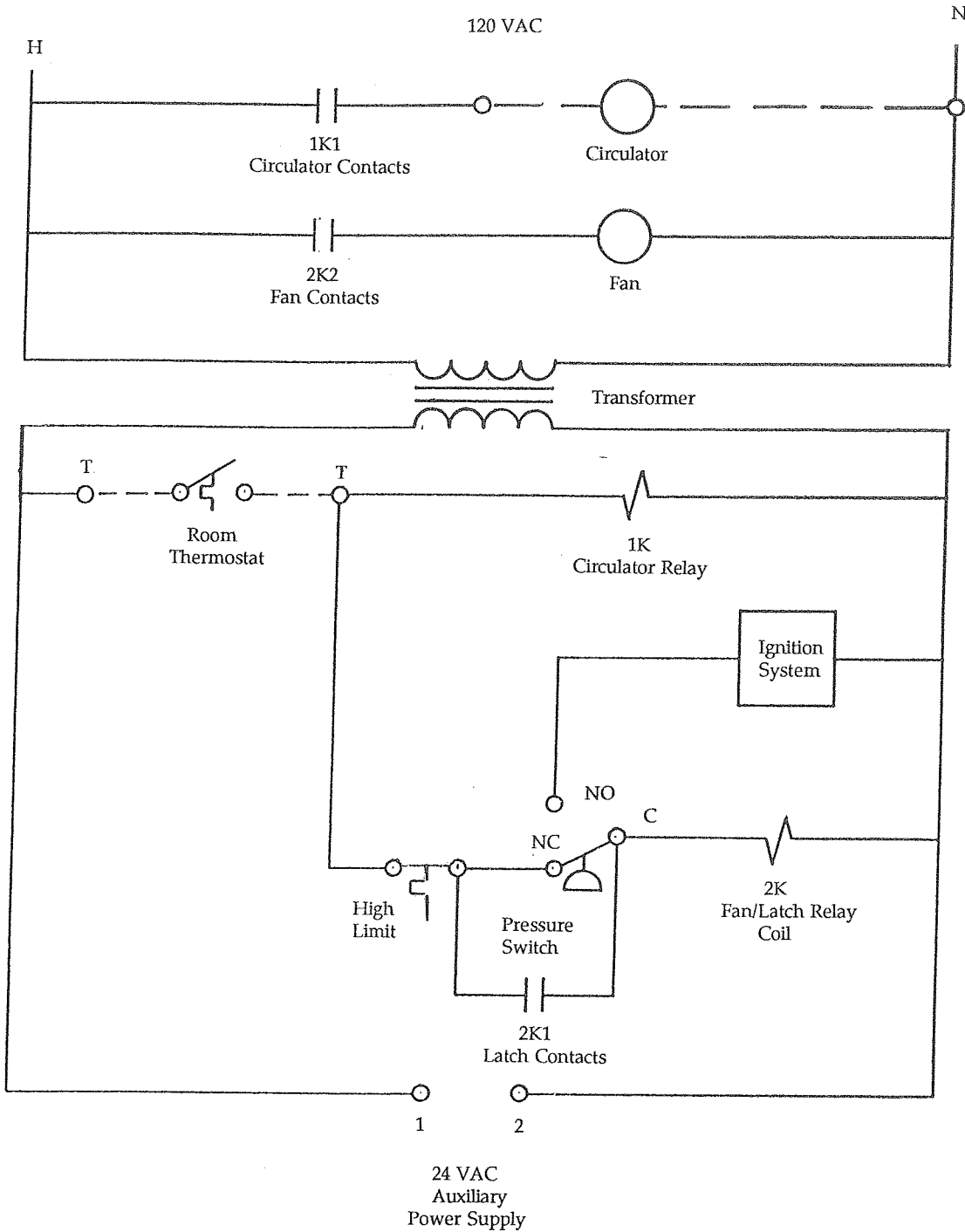

FIGURE 18: BOILER LADDER DIAGRAM



NOTE: System is shown in the deenergized position with thermostat open and high limit closed.

Factory Wiring

Field Wiring

FIGURE 19: BOILER CONNECTIONS DIAGRAM

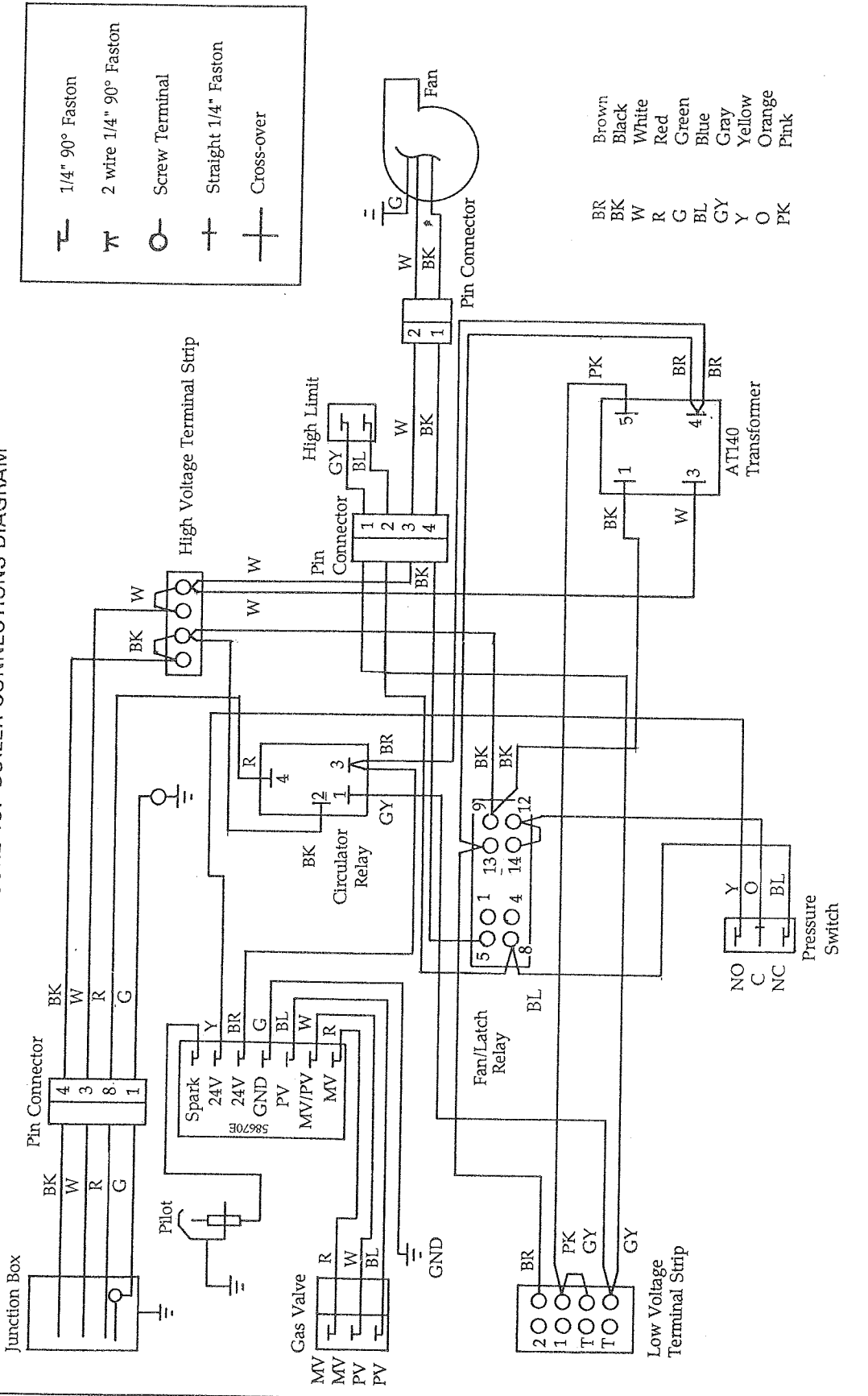

Note: If any wire must be replaced use:
 18 AWG 200C Type IFE for fan leads in casing
 16 AWG 105C Type AWM for all other wiring

APPENDIX A

IMPORTANT

The following information is provided to assist the installer who is permanently removing a gas fired appliance from a common venting system. It is provided for informational purposes only and is not directly relevant to the installation of a PF series boiler. NEVER ATTEMPT TO CONNECT A PF BOILER INTO A CHIMNEY.

At the time of removal of an existing boiler, the following steps shall be followed with each appliance remaining connected to the common venting system placed in operation, while the other appliances remaining connected to the common venting system are not in operation.

- (a) Seal any unused openings in the common venting system.
- (b) Visually inspect the venting system for proper size and horizontal pitch and determine there is no blockage or restriction, leakage, corrosion and other deficiencies which could cause an unsafe condition.
- (c) Insofar as is practical, close all building doors and windows and all doors between the space in which the appliances remaining connected to the common venting system are located and other spaces of the building. Turn on clothes dryers and any appliance not connected to the common venting system. Turn on any exhaust fans, such as range hoods and bathroom exhausts, so they will operate at maximum speed. Do not operate a summer exhaust fan. Close fireplace dampers.
- (d) Place in operation the appliance being inspected. Follow the lighting instructions. Adjust thermostat so appliance will operate continuously.
- (e) Test for spillage at the draft hood relief opening after 5 minutes of main burner operation. Use the flame of a match or candle, or smoke from a cigarette, cigar or pipe.
- (f) After it has been determined that each appliance remaining connected to the common venting system properly vents when tested as outlined above, return doors, windows, exhaust fans, fireplace dampers and any other gas-burning appliance to their previous conditions of use."
- (g) Any improper operation of the common venting system should be corrected so the installation conforms with the National Fuel Gas Code, ANSI Z223.1-1988. When resizing any portion of the common venting system, the common venting system should be resized to approach the minimum size as determined using the appropriate tables in Appendix G in the National Fuel Gas Code, ANSI Z223.1-1988.

Never connect appliances vented by natural draft into any portion of mechanical draft systems operating under positive pressure.

APPENDIX B: REPLACEMENT PARTS

IMPORTANT

- 1) This boiler uses a mixture of metric and english threaded fasteners. These fasteners are specified in the following parts lists ("M5" and "5 millimeter" are the same thread diameter). All specified metric fasteners are available through Crown Distributors and may also be found in some hardware or auto supply stores.
- 2) It is extremely important that the casing and fan seals be maintained (see Part XI, for more information on this). When replacing parts be sure to have silicone sealant and any extra gaskets on hand which might be damaged during the replacement process.
- 3) All replacement parts (except for screws and other common hardware) must be factory original unless otherwise noted. They must be installed by a qualified serviceman.
- 4) Replacement parts are available through Crown distributors only. We do not sell direct.

CASING AND VENT COMPONENTS

KEY #	DESCRIPTION	CROWN PART #	QUANTITY PER BOILER
1	Vent Terminal Mounting Screw Pkg.	10-193	Pkg. C
2	Vent Terminal	10-135	1
3	Wall Plug	10-194	Pkg. B
4	Wall Plug Screw	10-194	Pkg. B
5	Rope Sealing Ring	10-136	1
6	Vent Tubes, Standard	10-124	
6	Vent Tubes, 78 in.	10-195	
7	Sealing Collar (side vent only)	10-137	1
8	Casing Door	10-211	1
9	Casing Door Gasket	10-152	1
10	Sight Glass Gasket	10-153	2
11	Sight Glass	10-156	1
12	Sight Glass Retainer	10-154	1
13	6-32 Hex Nut	90-011	3
14	M6 x 15 Casing Door Screws	10-196	2
15	Retainers for Casing Door Screws	10-197	2
16	8-32 x 1/2 Philips Head Machine Screws	90-014	18
17	Utility Box	96-001	1
*	Cover for Utility Box	96-002	1
18	Strain Relief Adapter	10-173	1
19	Strain Relief	10-033	1
20	Line Voltage Harness	10-161, 10-032	1 each
21	#10 x 3/16 Sheet Metal Screw	90-007	6
22	Pipe Seal Plate	10-023	2
23	Pipe Seal Gasket	10-024	2
24	M5 Wing Nut	10-019	16
25	Pinhole Grommett	10-026	5
26	Pressure Sensing Tubes	10-020	2
27	Pressure Sensing Tube Grommetts	10-021	4
28	Ignition Wire Grommett	10-021	1
29	Control Cover Bracket	10-036	1
30	1/4-20 Knurled Screw	10-051	1
31	Retainer for (30)	10-052	1
32	Control Cover	10-212	1
33	5/16 x 2" Lag Screw	90-010	6
34	5/16 Flat Washer	90-008	6
35	5/16 "Long" Lag Shield	90-009	6
36	Boiler Mounting Bracket	10-128	1
37	Rear Vent Gasket (rear venting only)	10-129	1
38	5mm x 850mm Rope	10-120	1
39	Casing	10-110	1
40	Retaining Clips	10-043	8
41	M5 x 15 Cap Screw	90-017	2
42	1/4 - 20 x 1/2 Truss Hd. Screw	90-005	4
43	Control Tray Chassis (Metal only)	10-086	1
44	Boiler Hook	10-118	1
45	M8 x 10mm Cap Screw	10-119	2
46	Vent Cover Gasket	10-116	3
47	Vent Cover	10-117	3
48	Support Channels	10-112	2
49	M5 x 12mm Machine Screw	10-115	6
50	Chassis Support Bracket	10-027	1
51	1/4-20 x 5/8 Machine Screw	90-015	2
52	1/4-20 Thin Nut	90-004	2
53	#10 x 1 1/4 Sheet Metal Screw	90-018	2
54	3/16 USS Washer	90-020	2
55	#10 Plastic Anchor	90-019	2

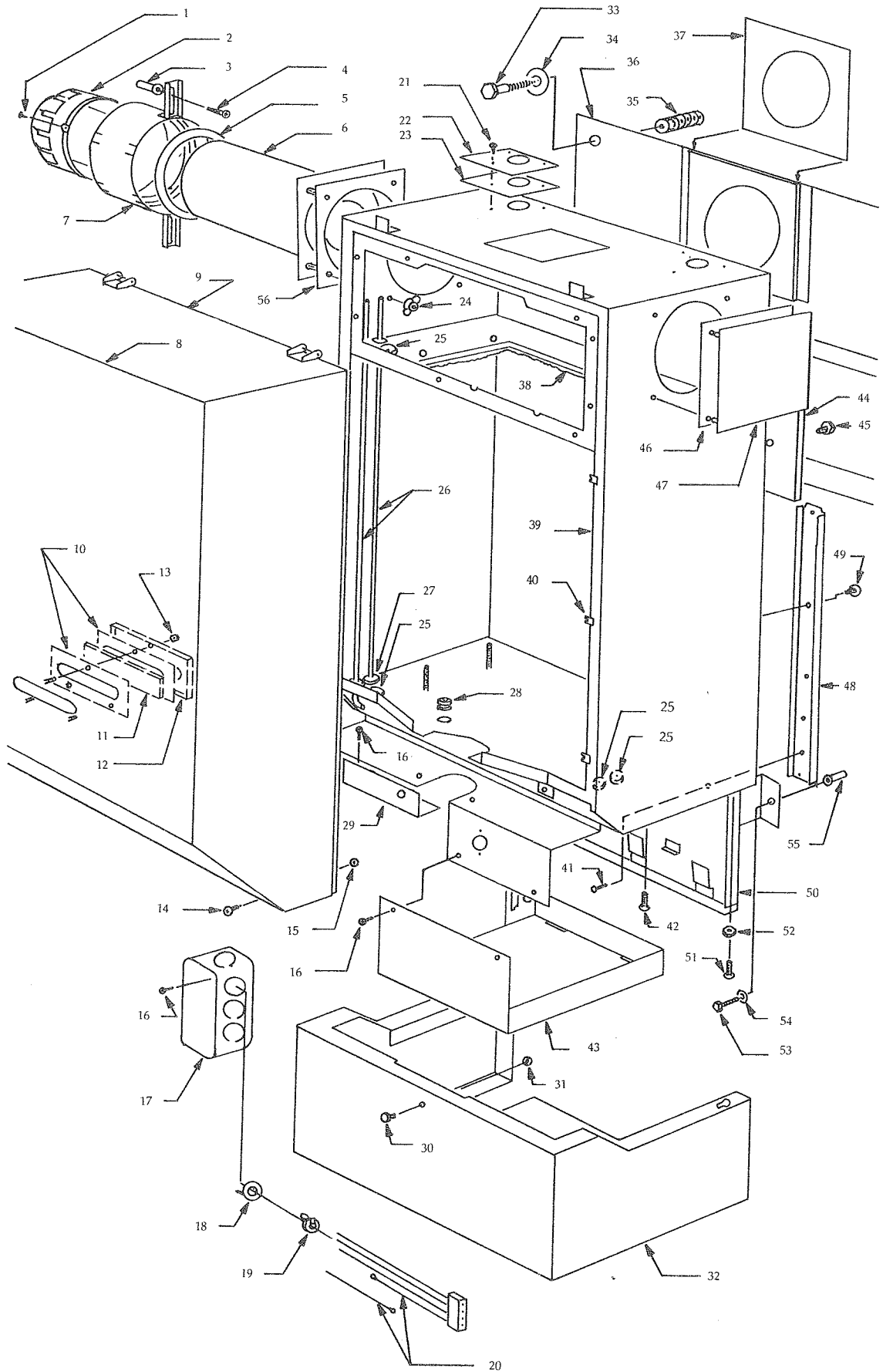

INNER CASING COMPONENTS

KEY #	DESCRIPTION	CROWN PART #	QUANTITY PER BOILER
56	Vent Tube Gasket	10-134	1
57	Elbow Extension (side vent only)	10-142	1
58	Upper Silicone Pressure Sensing Tubing	10-046	2
59	Flue Elbow	10-017	1
61	Flue Elbow Gasket	10-018	1
62	Flue Orifice for:		
	PF 50	10-016	
	PF 65	10-015	
	PF 82	10-014	
63	Flue Collector	10-013	1
64	Fan Mounting Plate Gasket	10-146	1
65	Fan Mounting Plate	10-144	1
66	M5mmx15mm Dog Point Screw	10-045	15
67	Fan Gasket	10-145	1
68	M8mm Hex Nut	10-009	24
69	3/4 x 8 1/2 Nipple	95-001	2
70	Flue Collector Gasket (12mm x 850mm Rope)	10-199	1
71	Flue Baffle (PF 65 and 82 only)	10-012	1
72	M8mm Thin Hex Nut	10-122	4
73	High Limit Well	10-083	1
74	High Limit Retainer Pin	10-044	1
75	M8 x 32mm Stud	10-121	4
76	Heat Exchanger	10-078	1
77a	Heat Exchanger Cover	10-079	2
77b	Heat Exchanger Cover Gasket	10-080	2
78	M8 Washer	10-082	16
79	M8x27 Studs	10-081	16
80	Dart Clip	10-062	2
81	Firedoor Insulation	10-061	1
82	Firedoor Assy, Metal Only	10-200	1
83	Firedoor Sight Glass	10-063	1
	Firedoor Assembly Complete	10-215	
84	#6 x 1/4 Sheet Metal Screw	90-002	2
85	M8 x 18mm Stud	10-008	4
86	Firebox	10-001	1
87	Side Firebox Insulation	10-002	2
-	Rear Firebox Insulation	10-003	1
88	Cerablanket Strip	10-011	1
89	Left Side Baffle	10-004	1
90	Right Side Baffle	10-005	1
91	M5 Hex Nut	10-010	8
92	Bottom Radiation Shield	10-006	1
93	Radiation Shield Spacers	10-007	4

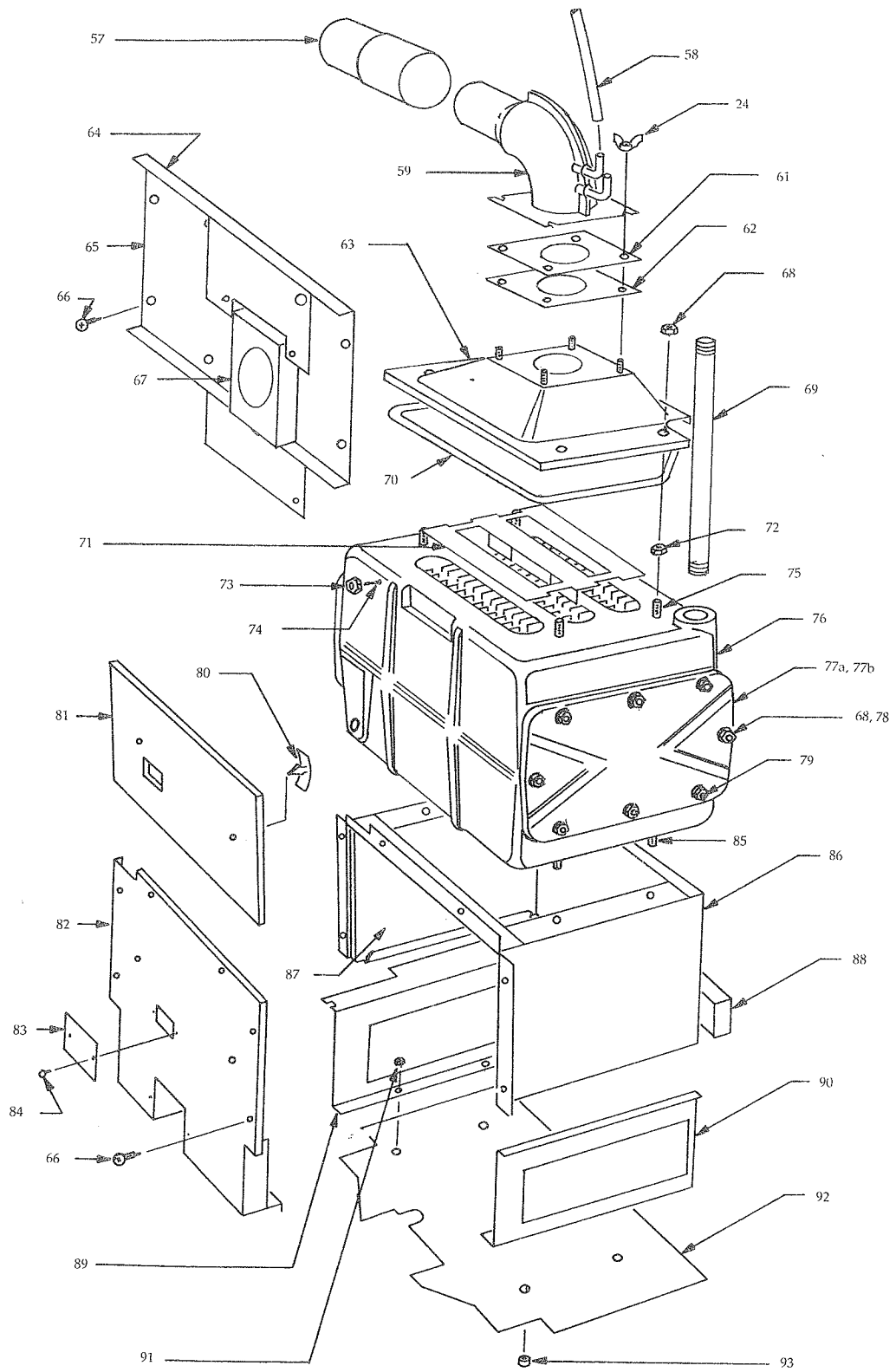

BURNER ASSEMBLY

KEY	DESCRIPTION	CROWN PART #	QUANTITY PER BOILER
94	Pilot Assembly		
	For Natural Gas (Q345A 2014)	10-066@	1
	For Propane (Q345A 2006)	10-157	1
	(Includes key parts 97 or 98)		
95	Ignition wire assembly (Honeywell 394803)	10-041	1
96	10-32 x 3/16 Machine Screws	90-007	2
97	Pilot Orifice		
	For Nat Gas Boilers (0.018")	85-002	
	For LP Gas Boilers (0.012")	85-001	
98	Pilot Tube Ferrule (long)	85-003	
99	Pilot Tube (1/8 OD)	10-067	1
101	Burner	10-065	1
102	3/8" Gas Valve Elbow (Honeywell 393670)	10-077	1
103	8-32 x 1/2 Screw	Part of 10-077	2
104	8-32 x 1-1/4 Screw	Part of 10-077	2
105	"O" Ring	Part of 10-077	1
106	Main Burner Orifice:		
	PF 50 (#22 Drill)	10-073	1
	PF 65 (#17 Drill)	10-072	1
	PF 82 (#12 Drill)	10-071	1
	PF 50LP (#41 Drill)	10-076	1
	PF 65LP (#36 Drill)	10-075	1
	PF 82LP (#32 Drill)	10-074	1
107	Gas Valve		
	Nat Gas (VR8204A-2274)	10-068*	1
	LP Gas (VR8204A-2282)	10-158	1
108	Pilot Tube Ferrule (Short)	85-004	
109	Gas Valve Brace	10-037	1
110	8-32 x 1/4 Truss Hd. Machine Screw	90-016	2
	PF50 Burner Assy. Complete	10-201	
	PF65 Burner Assy. Complete	10-202	
	PF82 Burner Assy. Complete	10-203	
	PF50LP Burner Assy. Complete	10-204	
	PF65LP Burner Assy. Complete	10-205	
	PF82LP Burner Assy. Complete	10-206	

* If a replacement VR8204A2274 is not available, a VR8204A2241 (used on some Crown ABF's, XE's and JBF's) may be used with the manifold pressure readjusted to 4.0" w.c..

@ A Honeywell Tradeline Q345A1313 may be used as a replacement for this.

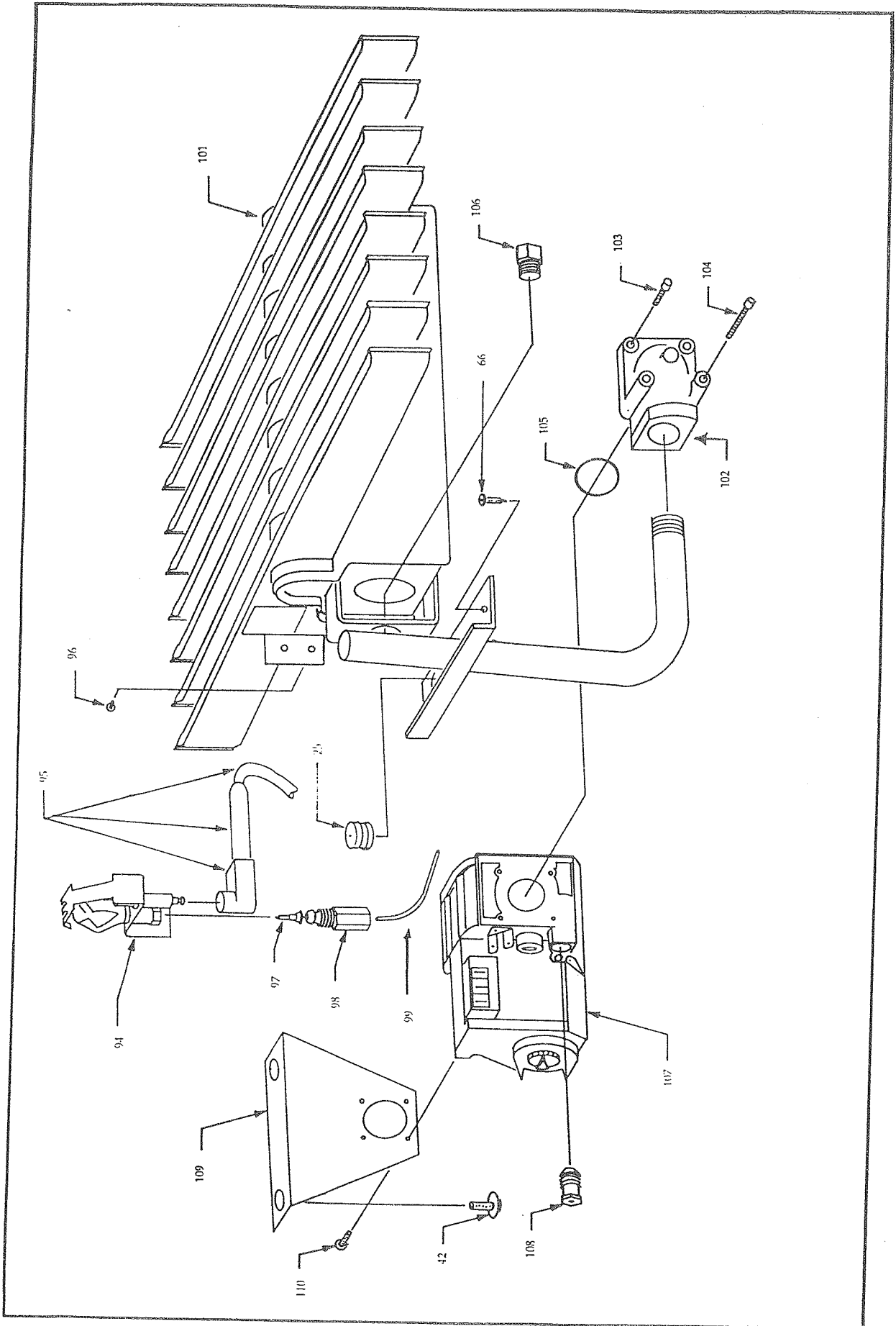

FAN AND FAN HARDWARE

KEY	DESCRIPTION	CROWN PART #	QUANTITY PER BOILER
111	8-32x1 1/2 Screw	90-013	3
112	8-32 Lock Washer	90-003	3
113	Fan	10-143	1
114	Strain Relief	10-148	1
115	Pin Connector Male Shell	10-149	1
116	Pins for Key #115	10-150	2
117	Wire Harness "N"	10-040	1
	Fan Asssy. Complete	10-207	

CONTROL COMPONENTS

KEY	DESCRIPTION	CROWN PART #	QUANTITY PER BOILER
118	High Voltage Terminal Strip	10-095	1
119	S8670E1007	10-087+	1
120	Differential Pressure Switch	10-089	1
121	Low Voltage Terminal Strip	10-093	1
122	Marker Strip	10-094	1
123	Honeywell AT140	10-088	1
124	Circulator Relay	10-090	1
125	Fan/Latch Relay Base	10-092	1
126	Fan/Latch Relay	10-091	1
	Honeywell L4189B2012 High Limit	10-030	1
	Control Tray Wire Harness Sets:		
	High Voltage Wire Harness Set	10-216	1
	Low Voltage Wire Harness Set	10-217	1
	Gas Valve Wire Harness	10-106	1
	Gas Valve Harness Strain Relief	10-108	1
	6-32x1/2 Machine Screws for Key #124	90-002	2
	Jumpers for Terminal Strips	10-096	3
	Control Assy. Complete	10-208	

Notes:

+NOT interchangeable with S8600 modules used on other Crown Boilers.

8-32x1/2 Machine Screws (Key #40) used to attach all controls and devices to tray except for circulator relay.

FAN AND FAN HARDWARE

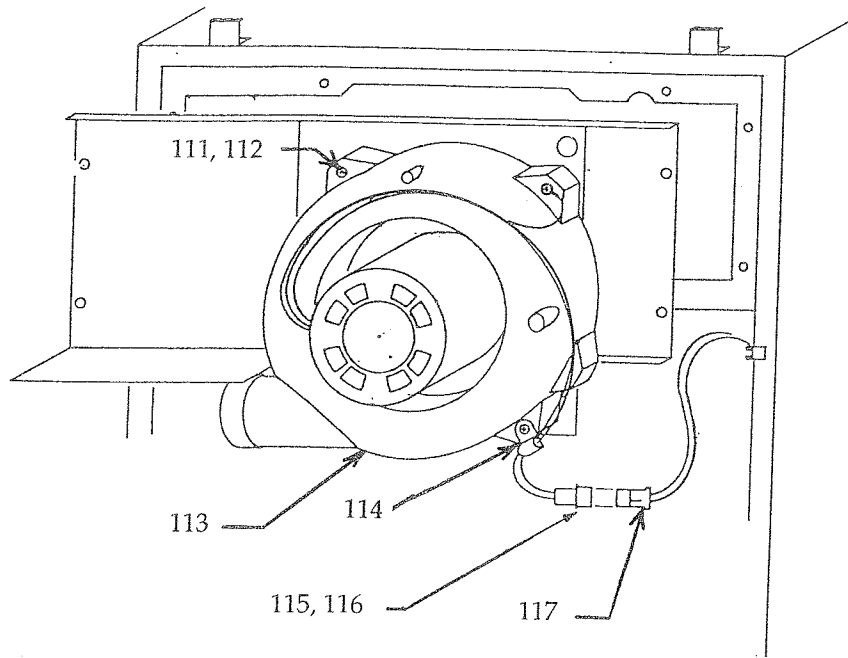

CONTROL TRAY TOP VIEW

Wiring Harnesses omitted for clarity

