LP Gas (Propane) Conversion Instructions

Combi Boilers Only

⚠ DANGER! Asphyxiation Hazard. These instructions include a procedure for adjusting the air-fuel mixture on this boiler. Always use a combustion analyzer to measure the CO₂ (or Oxygen) and Carbon Monoxide (CO) levels in flue gas. Adjusting the air-fuel mixture without a proper combustion analyzer will result in unreliable boiler operation, personal injury, or death due to carbon monoxide poisoning.

Explosion Hazard, Electrical Shock Hazard, Burn Hazard. The gas supply shall be shut off prior to disconnecting the electrical power, before proceeding with the conversion.

⚠ WARNING! This conversion kit shall be installed by a qualified service agency in accordance with the manufacturer's instructions and all applicable codes and requirements of the authority having jurisdiction. If the information in these instructions is not followed exactly, a fire, an explosion, or production of carbon monoxide may result causing property damage, personal injury, or loss of life. The qualified service agency is responsible for proper installation of this kit. The installation is not proper and complete until the operation of the converted appliance is checked as specified in the manufacturer's instructions supplied with the kit.

These instructions are intended for use only with sizes listed in this document.

If boiler can be installed at altitude, consult Appendix A in Installation, Operating and Service (I, O & S) Instructions for installations above 2,000 ft. I, O & S Instructions are supplied with boiler and available on manufacturer's website.

These instructions are included in LP conversion kits listed in Table 1:

Table 1: LP Conversion Kits

Size	LP Conversion Kit
135-150	107874-01
180	107875-01

Required Tools/Equipment:

- 10mm Wrench (Cold Burner Door)
- (2) Adjustable Wrenches
- Torx T-25 (Gas Valve to Venturi)
- Torx T-30 (Venturi Assembly to Blower)
- Phillips Head Screwdriver
- Flat Head Screwdriver
- Combustion Analyzer

Included with this Kit:

- LP Venturi
- Hardware
- Blower O-ring (Blower to Venturi)
- Gas Valve Coupling (Venturi to Gas Valve)
- Rating Plate Label
- Service Label

1. **Disconnect power supply to boiler.**
2. **Shut-off gas supply to boiler.**
3. If not already done, install the boiler in accordance with the Installation, Operating, and Service instructions, following all instructions in Section XII "Start-up and Check-out" up to Step 10.
4. Disconnect tube to air proving switch and disconnect the ends of these wire harnesses (Figure 1 & 2):
 - a. At gas valve.
 - b. Two connections at back of blower (not shown).
 - c. Two connections at ignitor.
 - d. At flame sensor.
 - e. Three connections at top of control box.
 - f. Display harness at control.
 - g. Harness connection at PCB.
 - h. Power supply connection from J-Box assembly.
5. Remove intake attenuator if applicable (Figure 1).

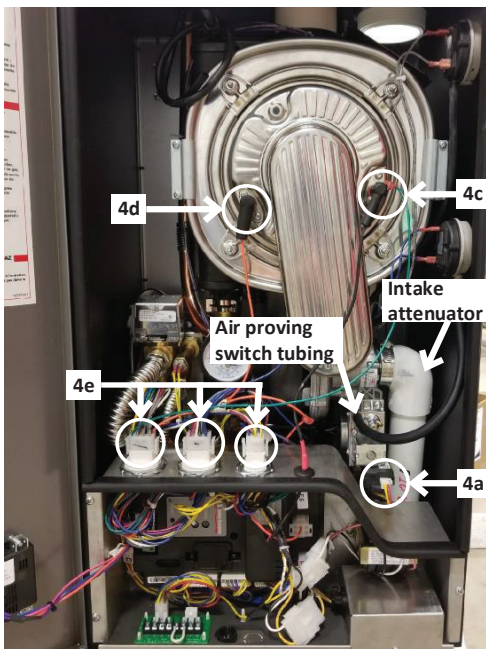

Figure 1

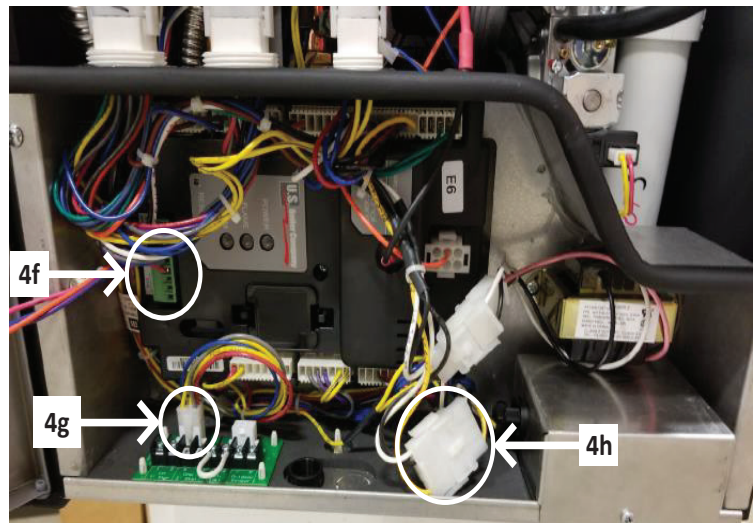

Figure 2

- Remove the (3) screws from control box assembly and remove control box assembly from boiler.

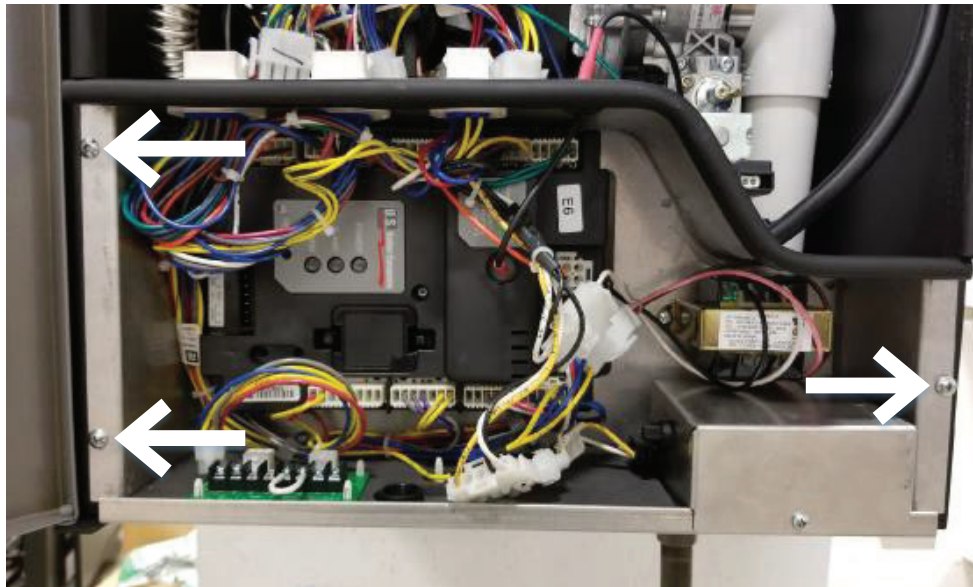

Figure 3

- If the gas piping is already installed and the boiler manual is followed, a 1/2" union should be installed directly under the boiler as shown in Figure 4. If so, the blower/gas valve assembly can be removed from the boiler with the top half of this union in place. Break this union using a "backup wrench" on the top (male) half of the union to protect the boiler gas piping from excessive torque. Note: If there is no union at the location shown, break the gas line at the closest convenient point and remove the gas piping attached to the boiler (when re-assembling install a 1/2" union as shown in Figure 4).
- Remove the (2) 8-32 screws and nuts holding the gas line sealing plate to the bottom jacket panel (Figure 5).
- Remove the (4) 10mm nuts that attach the cold burner door to the heat exchanger (Figure 6).
- Slide the cold burner door off the heat exchanger studs. Once the door is clear of the studs, the entire door/ blower/gas valve/gas pipe assembly can be lifted out of the boiler.

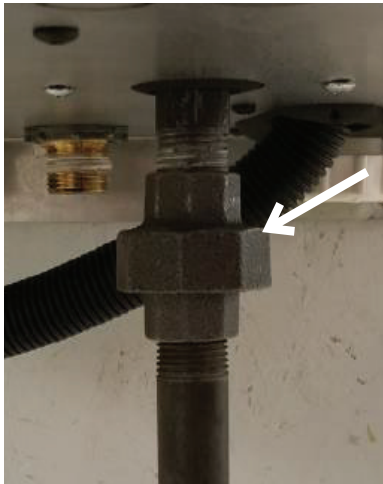

Figure 4

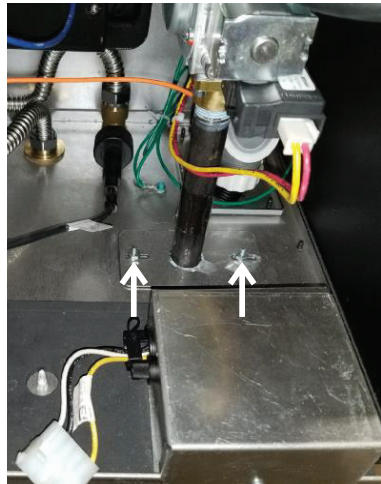

Figure 5

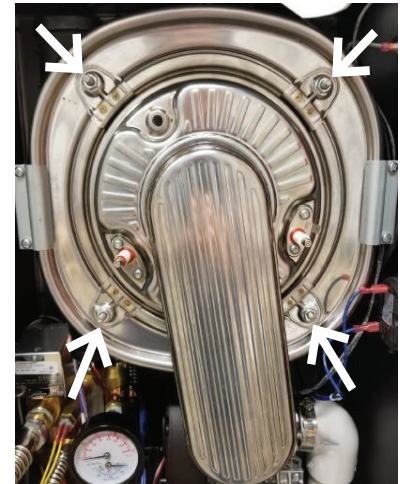

Figure 6

⚠ WARNING! Fire Hazard. Explosion Hazard. Always use back-up wrench when making or breaking gas line connection. Failure to do so can cause damage to gas valve or cause adjacent threaded connections to loosen. Check all internal gas piping for leaks any time it is disconnected or disturbed during servicing.

See Figure 7 :

11. (on bench) Remove (2) screws connecting gas valve to venturi assembly.
12. Remove (3) screws connecting venturi assembly to blower.
13. Replace natural gas venturi assembly with propane (LP) venturi assembly, ensuring O-ring between blower and venturi assembly is in place and arrow on venturi points up.
14. Secure venturi assembly to blower using (3) screws removed in step 12.
15. Ensure coupling between venturi assembly and gas valve is in place and secure using (2) screws removed in step 11.
16. Reconnect cold burner door to heat exchanger using (4) 10mm nuts removed in step 9.
17. Reconnect gas piping.
18. Re-connect tube to air proving switch, intake attenuator, and all electrical connections.
19. Check all gas connections for leaks.
20. Before attempting to start the boiler, turn the throttle (Figure 9) clockwise until it stops (several turns).
21. Turn throttle counter-clockwise the exact number of turns shown in Table 8.

⚠ WARNING! Explosion Hazard. Gas leaks could cause severe property damage, personal injury or death. Do not use matches, open flame, or other ignition sources to check for leaks.

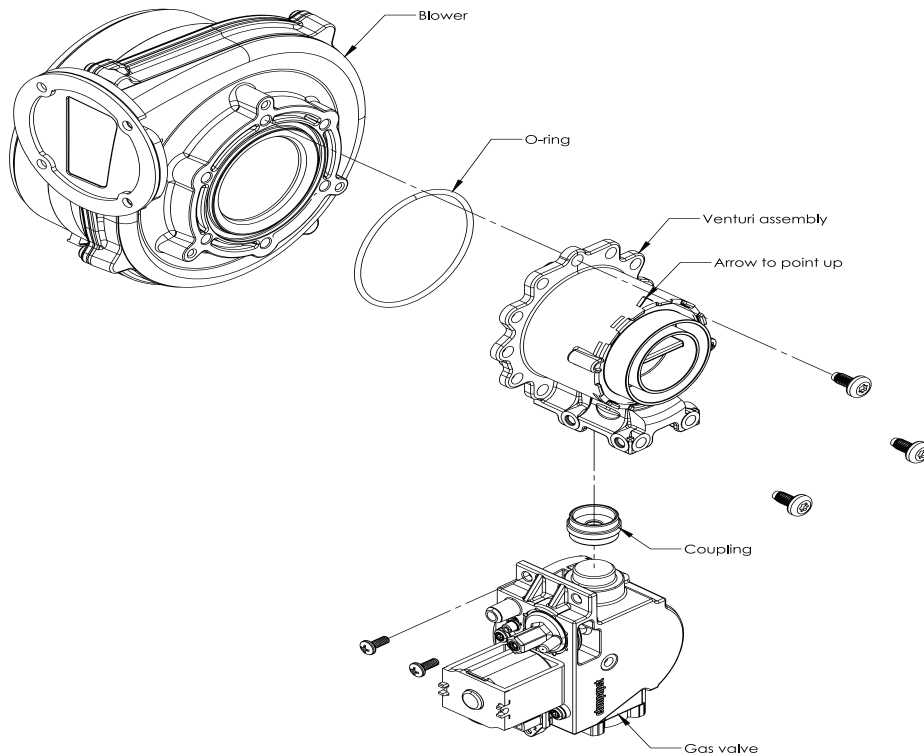

Figure 7: Gas Line Union

⚠ WARNING! The throttle adjustments in Table 8 are approximate. The final throttle setting must be found using a combustion analyzer. Leaving the boiler in operation with a CO level in excess of 200PPM air-free could result in injury or death from carbon monoxide poisoning.

Table 8: Starting Number of Throttle Turns for Conversion to LP Gas

Boiler Size	# Counter-clockwise Turns (From Fully Closed)
135	9
150	10
180	14

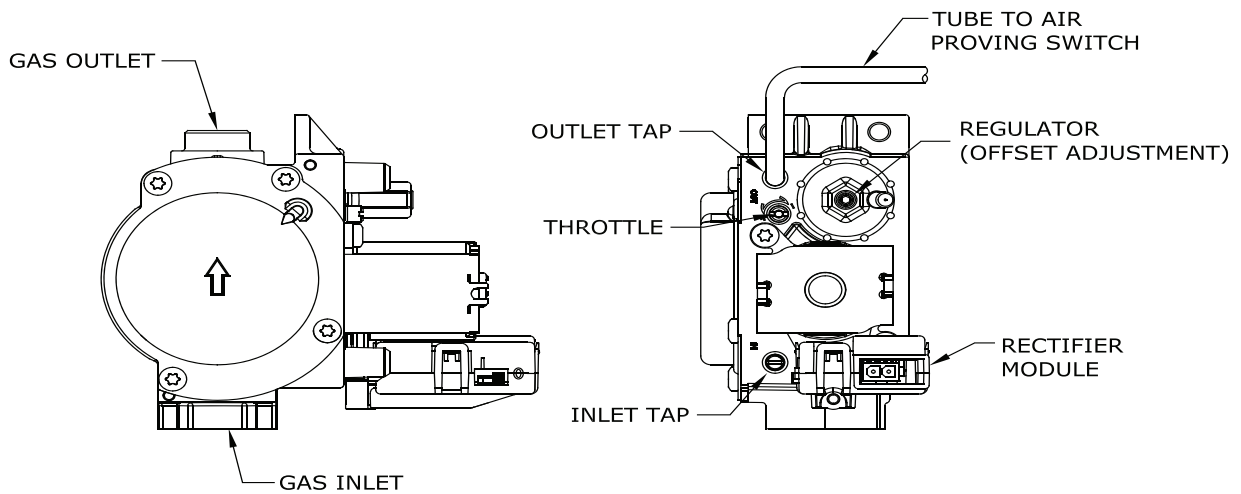

Figure 9: Gas Valve Detail

22. Select the correct boiler size, altitude, and fuel using the touch screen display:
 - a. Check boiler's rating label for actual boiler size.
 - b. Confirm installation altitude.
 - c. Press "Adjust" button on the Home screen.
 - d. Press "Adjust" button on the Adjust Mode screen.
 - e. Press "Login" button to access Password screen.
 - f. Press 5-digit display to open a keypad. **Enter the password "86"** and press the return arrow to close keypad. Press "Save" button.
 - g. Press "Adjust" button to enter Adjustment Mode.
 - h. Press "Modulation Setup" menu button.
 - i. Press "Adjust" button after reading Warning screen.
 - j. Use the ↓↑ arrow buttons to select the correct size, altitude, and fuel of your boiler. Press the (Check with Circle) button to enter your selection.
 - k. Press "Enter" button until display stops blinking, press next and repeat until "Completed" is displayed.
 - l. Press X to exit.
 - m. Press "Confirm" to verify correct size, altitude, and fuel is displayed.

⚠ WARNING! All combustion performance numbers MUST be verified with a combustion analyzer. Failure to do so could result in substantial property damage, severe personal injury or death.

23. Attempt to start the boiler using the operating instructions located on inside of boiler front door. If the boiler does not light on the first try for ignition, allow boiler to make at least five more attempts to light. If boiler still does not light, turn the throttle counter-clockwise in 1/8 turn increments, allowing the boiler to make at leave five tries for ignition at each setting until the boiler lights.
24. After the burner lights, force the burner to high fire by entering the Adjust Menu and the High Fire Hold as described in Section XII "Start-up and Checkout" of I, O & S Instructions. Allow the boiler to operate for approximately 5 minutes before taking combustion readings. Note: after 10-15 minutes, the boiler is automatically released from high fire hold.
25. Perform a combustion test, sampling flue products from the tap in front of the vent adapter.
26. With burner at high fire, adjust throttle as needed to obtain CO₂ (or O₂) setting shown in Table 10:
 - To reduce CO₂ (increase O₂) turn throttle clockwise. ↻
 - To increase CO₂ (reduce O₂) turn throttle counter-clockwise. ↺

Make adjustments in increments of 1/8 and 1/4 turns and allow the boiler at least a minute to respond to each adjustment before making another.

27. Force burner to low fire by entering the Adjust Menu and then Low Fire Hold as described in Section XII "Start-up and Checkout". Allow the boiler to operate for approximately 5 minutes before taking combustion readings.

⚠ WARNING! Asphyxiation Hazard. Use combustion analyzer for all gas valve adjustments. Low fire offset screw is very sensitive. Adjust offset no more than 1/8 turn before checking combustion with analyzer. Maximum total offset adjustment ± 1 turn. Adjustments greater than ± 1 turn may damage regulator diaphragm. Failure to follow these instructions could result in death, serious injury or substantial property damage.

28. With burner at low fire, offset regulator as needed to obtain CO₂ (or O₂) setting shown in Table 10:
 - To reduce CO₂ (increase O₂) turn offset regulator counter-clockwise. ↻
 - To increase CO₂ (reduce O₂) turn offset regulator clockwise. ↺

Make adjustments in increments of no more than 1/8 turn and allow the boiler at least a minute to respond to each adjustment before making another.

Table 10: Acceptable Combustion Readings for LP Gas (Propane) Operation

Acceptable %CO ₂ Combustion Readings for LP Gas (Propane)*									
Boiler Size	Altitude								Max. CO Air Free
	0-2,000 ft.		2,001-6,000 ft.		6,001-7,800 ft.		7,801-10,100 ft.		
	Range	Target	Range	Target	Range	Target	Range	Target	
135	9.8-10.1	10.0	9.4-9.7	9.7	9.8-10.1	10.1	Not Permitted		COAF readings must be less than 200 ppm.
150			9.5-9.8	9.8	9.5-9.8	9.8	9.5-9.8	9.8	
180			Not Permitted						

* Low Fire Range and Target values are the same as High Fire above. Ensure low fire CO₂ reading is less than or equal to high fire CO₂ reading.

Acceptable %O ₂ Combustion Readings for LP Gas (Propane)**									
Boiler Size	Altitude								Max. CO Air Free
	0-2,000 ft.		2,001-6,000 ft.		6,001-7,800 ft.		7,801-10,100 ft.		
	Range	Target	Range	Target	Range	Target	Range	Target	
135	5.5-6.0	5.7	6.2-6.6	6.2	5.6-6.0	5.6	Not Permitted		COAF readings must be less than 200 ppm.
150			6.0-6.5	6.0	6.0-6.5	6.0	6.0-6.5	6.0	
180			Not Permitted						

* Low Fire Range and Target values are the same as High Fire above. Ensure low fire O₂ reading is greater than or equal to high fire O₂ reading.

Table 11: Altitude Derates for LP Gas (Propane) Operation

Boiler Size	Approximate Derate per 1000 ft.		
	2,001-6,000 ft.	6,001-7,800 ft.	7,801-10,100 ft.
135	1.7%	3.3%	Not Permitted
150	3.2%	3.0%	3.3%
180	Not Permitted		

29. Verify gas inlet pressure is between 11.0 and 14.0 inches w.c. with all gas appliances (including converted boiler) both on and off.
30. A sheet of yellow labels is provided with these instructions for boilers converted from natural to LP gas. Select the respective firing rate for the boiler being converted from this sheet of labels and apply them as follows:
 - Apply the "Rating Plate Label" adjacent to the rating plate.
 - Apply the "Gas Valve Label" to a conspicuous area on the gas valve.
 - Apply the "Boiler Conversion Label" to a conspicuous surface on, or adjacent to, the outer boiler jacket. Fill in the date of the conversion and the name and address of the company making the conversion with a permanent marker.
31. A label with acceptable LP combustion readings is provided with these instructions. Affix this label in a conspicuous location on the boiler.
32. Refer to the Section XII " Start-up and Checkout" in the I, O, and S Instructions and perform any checks not already completed.

