



Phantom II 136C, 200C, 080H, 120H, 120HB, 150H, 180H

Residential High Efficiency  
Hot Water Condensing Gas Boilers

PHNTM2 Combi/Heat Only Submittal Sheet

**PHNTM2 Wall Mount and Floor Standing Heating Boilers**

Wholesaler \_\_\_\_\_

Job Name \_\_\_\_\_

Mechanical Contractor \_\_\_\_\_

Model Number \_\_\_\_\_ Quantity: \_\_\_\_\_

Gas Type \_\_\_\_\_

BTU/hr INPUT \_\_\_\_\_

BTU/hr OUTPUT \_\_\_\_\_

Venting Application \_\_\_\_\_

**Standard Features - All Models**

- ASME Constructed 316L Stainless Steel Water Tube Heat Exchanger
- 30 psi Relief Valve, Maximum Allowable Working Pressure 50 psi
- 210F Maximum Allowable Temperature Setting, 180F Target Set Point
- Energy Star Qualified
- 95.0% AFUE
- 10:1 Turndown, Direct Vent Appliance
- 2" Vent/Air Adapters Standard for use with CPVC/PVC or Single Wall Polypropylene Venting with Optional Concentric Vent Terminals.  
3" Vent/Air Piping Optional with use of 2" x 3" Increaser.

Note: See Installation Manual for a List of Approved Vent Systems, Vent Length Limitations, and Other Installation Requirements

- Boiler Circulator (shipped loose on Heat Only Models)
- Pre-Installed UL 353 Listed Boiler Flow Switch
- Built-In Hanging Bracket with Wall Mount Kit
- Unobstructed access to inside of boiler is possible from either the front or sides.
- Boiler Control System with Large Key Control Pad & User Display
  - o "Gas adaptive technology" directly monitors & regulates air-fuel ratio.
  - o Natural to LP Conversion is accomplished by selecting fuel on display and on the gas valve. In addition some models require a different electrode when used with LP at altitudes above 2000ft. See installation manual for details.
  - o Built-in Rate Based Sensorless Reset, (no outdoor air sensor required)
  - o Self Diagnostics
  - o Combi models have built-in management for a DHW recirculation pump.
  - o Terminals for external limit(s)
  - o Terminals for optional LWCO kits
  - o Warm Weather Shutdown (requires outdoor air sensor)
  - o Fuse Protected, Spare Fuses Provided
- 12 Year Limited Heat Exchanger Warranty, 5 Year Warranty On Parts

**Standard Features - Combi Models**

- Integrated DHW Block with Flat Plate Heat Exchanger, Boiler Circulator, 3-Way Valve, Flow & Boiler Return Sensors & Automatic Air Vent
- Low Loss Header

**Optional Equipment**

- 2" CPVC/PVC Vent Kit, (PN 107039-01)
- 3" CPVC/PVC Vent Kit, (PN 107039-02)
- Hydrolevel 1100 Auto Reset LWCO Kit, (PN 105591-01)
- Hydrolevel 1100M Manual Reset LWCO Kit, (PN 108182-01)
- Ignitor/Flame Sensor Kit for Select LP Models at Altitude (PN 111745-01)
- Service Parts Kit (PN 431057)
- L4006E Manual Reset High Limit (PN 3503101)
- Floor Stand (PN 111576-01)
- Primary/Secondary Piping Kit, Heat Only (PN 111884-01)

**Special Job Notes:**

\_\_\_\_\_

\_\_\_\_\_

\_\_\_\_\_

\_\_\_\_\_

\_\_\_\_\_

\_\_\_\_\_

\_\_\_\_\_

\_\_\_\_\_

\_\_\_\_\_

\_\_\_\_\_

# PHNTM2 136C, 200C, 080H, 120H, 120HB, 150H, 180H

## Combi Model Shown

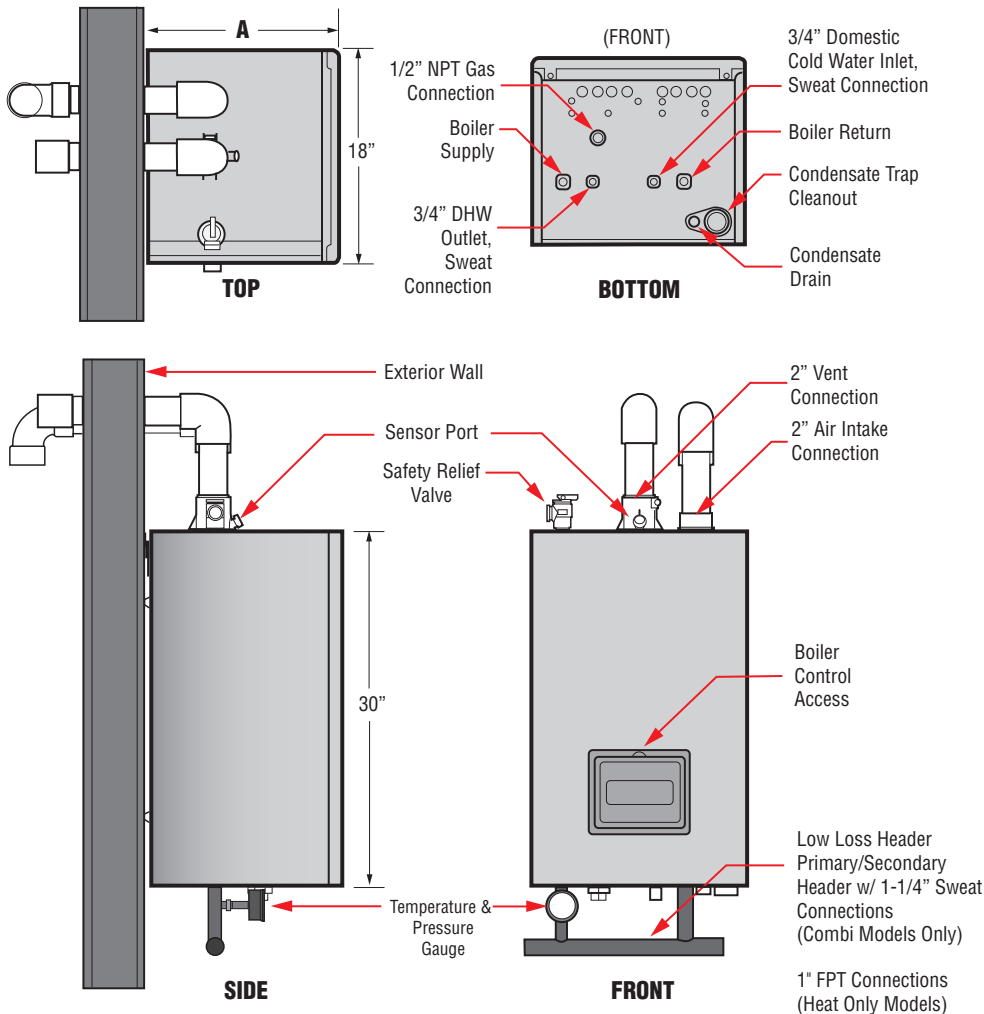

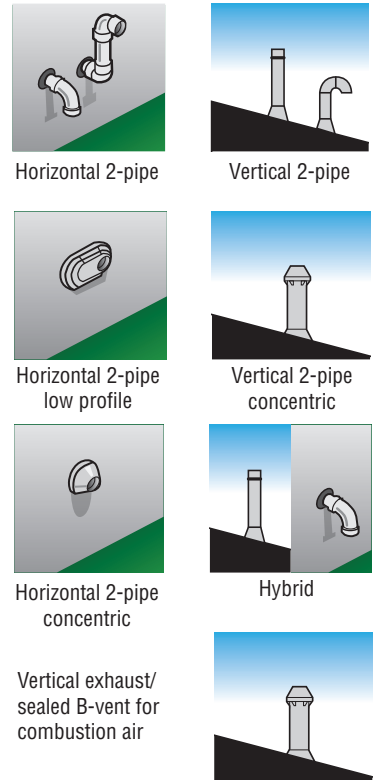

## Typical Venting Configurations (Horizontal and Vertical)

Illustrations are for representation only. For complete venting information, please see Installation, Operating and Service Instructions.



PLUS polypropylene chimney chase option

Space Heating Ratings					Domestic Hot Water (DHW) Ratings <sup>1</sup>				"A" Dimension	Empty Boiler Weight (lbs)
Model Number <sup>5</sup>	Input (MBH) Min-Max	Heating Capacity, MBH	Net AHRI Water, MBH <sup>2</sup>	  AFUE, %	Input (MBH) Min-Max	Max Draw GPM <sup>3,4</sup>				
						70°F Rise	77°F Rise	90°F Rise		
PHNTM2136C	13.6-120	112	97	95.0	13.6-136	3.7	3.4	2.9	16.3"	95
PHNTM2200C	20-150	141	123	95.0	20-200	5.2	4.7	4.0	20.4"	116
PHNTM2080H	8-80	75	65	95.0	-	-	-	-	16.3"	71
PHNTM2120H	13.6-120	112	97	95.0	-	-	-	-	16.3"	76
PHNTM2120HB										
PHNTM2150H	20-150	141	123	95.0	-	-	-	-	20.4"	103
PHNTM2180H	20-180	169	147	95.0	-	-	-	-	20.4"	103

**Notes:**

- DHW ratings are not AHRI certified.
- The Net AHRI Water Ratings shown are based on a piping and pickup allowance of 1.15. The manufacturer should be consulted before selecting a boiler for installations having unusual piping and pickup requirements, such as intermittent system operation, extensive piping systems, etc.
- Maximum draw rates shown are at sea level and minimum vent length. Under other conditions draw rates will be reduced proportionally to the reduction in input. See manual for input de-rate information.
- Minimum flow rate of 0.5 GPM required through the boiler to initiate a call for DHW. A higher flow rate may be required through the fixture due to mixing at the tempering valve and fixture itself.
- Consult installation manual for limitations on installations above 2000ft.

Venting Note: Size noted is for two pipe CPVC/PVC & certain specified two pipe polypropylene and vent systems. Concentric vent terminals permitted in most installations. See installation manual for venting option details.

# Combi Model Shown

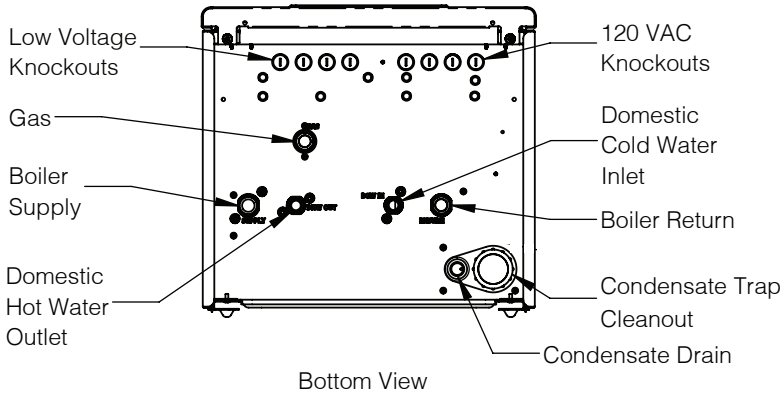
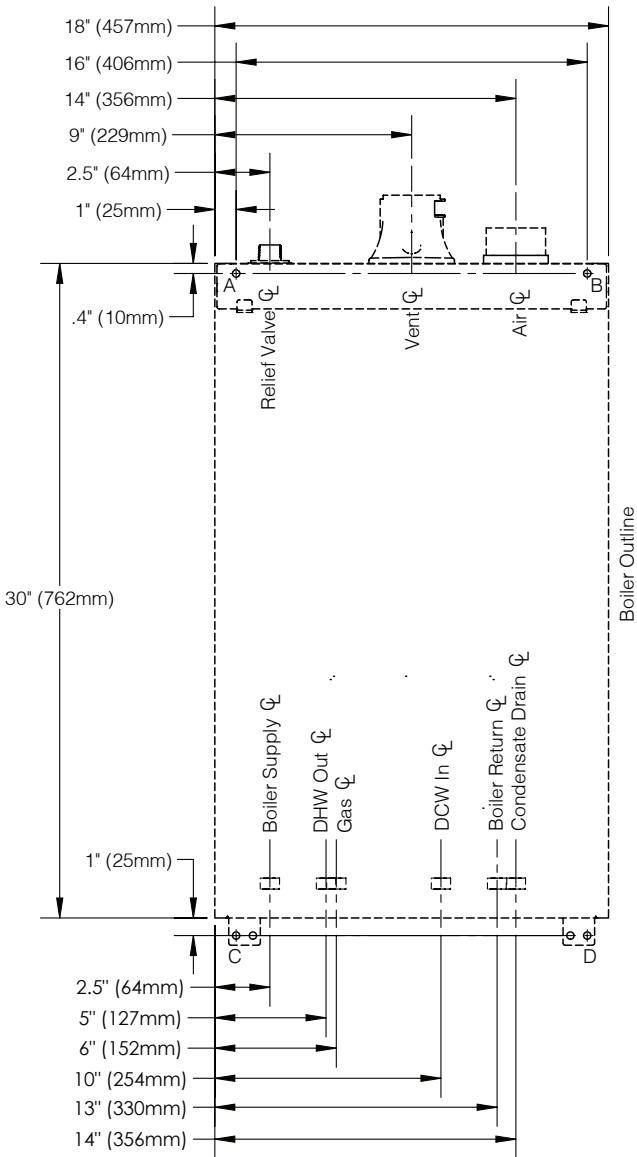

## Boiler Connections

### Wall Layout and Mounting Holes & Dimensions to Connections

## Heat Only Model Shown

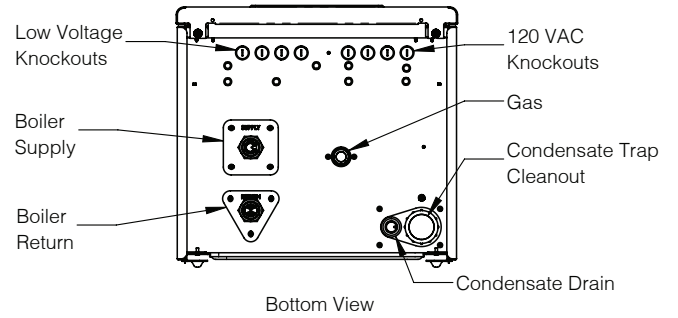
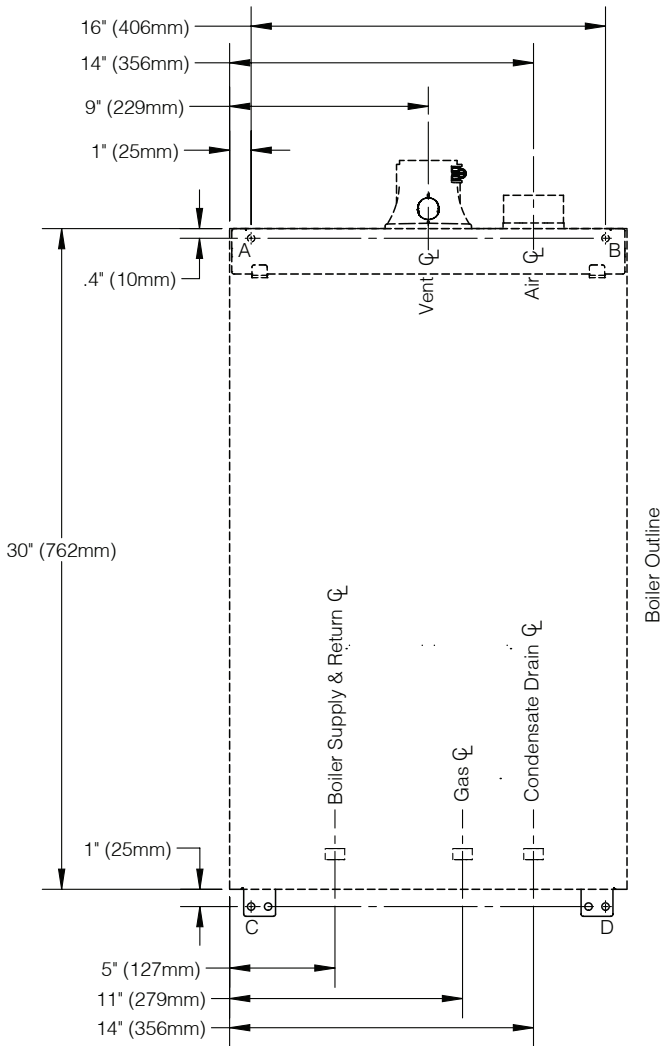

## Boiler Connections

### Wall Layout and Mounting Holes & Dimensions to Connections