

INSTALLATION INSTRUCTIONS

These instructions must be affixed on or adjacent to the boiler.

CROWN ARUBA SERIES

Gas-Fired Hot Water Boilers

These Gas-Fired Water Boilers are low pressure, sectional cast iron boilers Design Certified by A.G.A. (American Gas Association) and C.G.A. (Canadian Gas Association) for use with Natural and Propane Gases. They are constructed and hydrostatically tested for a maximum working pressure of 50 psi (pounds per square inch) in accordance with A.S.M.E. (American Society of Mechanical Engineers) Boiler and Pressure Vessel Code Section IV Standards for cast iron heating boilers.



MODEL ABF-SPD Continuous Pilot

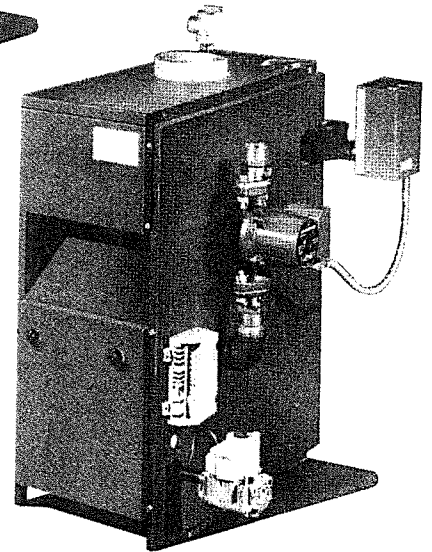
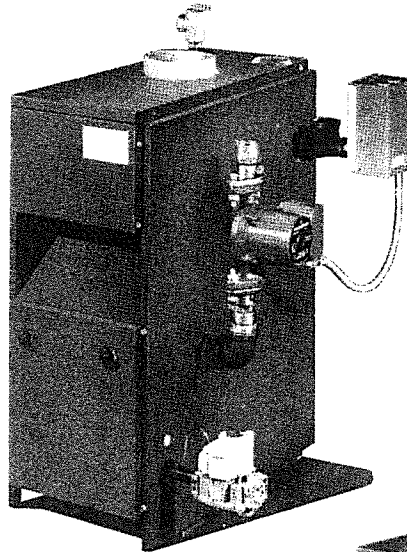

MODEL ABF-EID Electronic Intermittent Ignition

WARNING: Improper installation, adjustment, alteration, service or maintenance can cause injury or property damage. Refer to this manual. For assistance or additional information consult a qualified installer, service agency or the gas supplier. Natural gas boilers are not to be converted to Propane Gas.



CROWN BOILER CO.

P.O. Box 14818 • 3633 I Street • Philadelphia, PA 19134

(215) 535-8900

Boiler Ratings and Capacities

FIG. 1

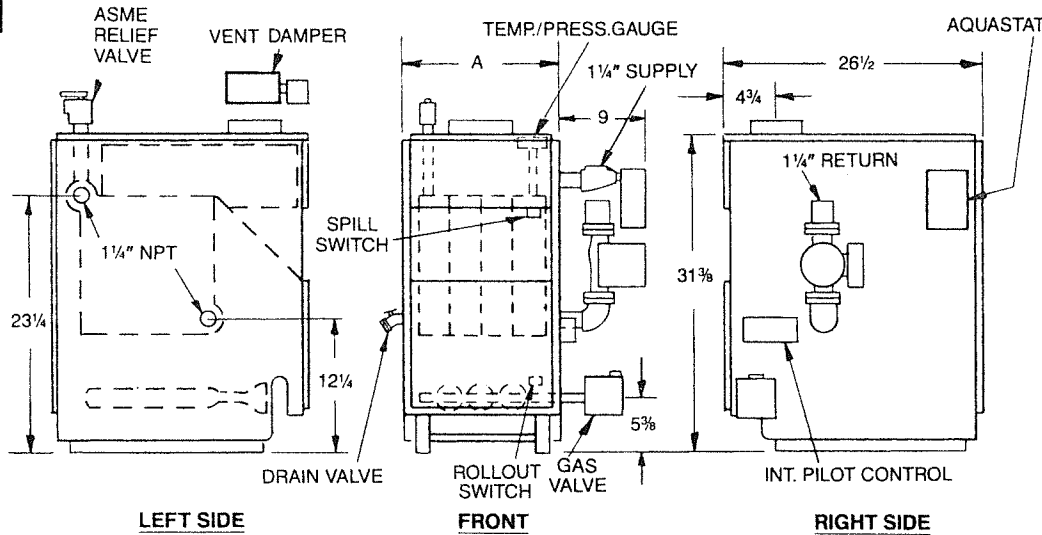

GAS-FIRED HOT WATER BOILERS

BASIC BOILER UNIT NO.		NO. OF SECTIONS	NATURAL AND PROPANE GAS			DIMENSIONS (Inches)	
Electronic Ignition With Vent Damper	Continuous Pilot With Vent Damper		AGA/CGA INPUT *MBH	HEATING CAPACITY *MBH	NET I=B=R RATING *MBH	FLUE DIAMETER	"A" WIDTH
ABF-38EID	ABF-38SPD	2	37.5	30	26	4‡	8
ABF-70EID	ABF-70SPD	3	70	57	50	5	11 1/4
ABF-105EID	ABF-105SPD	4	105	85	74	6	14 1/2
ABF-140EID	ABF-140SPD	5	140	113	98	6	17 3/4
ABF-175EID	ABF-175SPD	6	175	142	123	7	21
ABF-210EID	ABF-210SPD	7	210	170	148	7	24 1/4
ABF-245EID	ABF-245SPD	8	245	198	172	7	27 1/2
ABF-280EID	ABF-280SPD	9	280	226	197	7	30 3/4

* MBH = 1,000 Btuh Btuh = British Thermal Unit Per Hour

Boilers are equipped for altitudes up to 2,000 feet only.

U.S.A. Only - For altitudes above 2,000 feet, ratings should be reduced at the rate of 4% for each 1,000 feet above sea level.

Canada Only - Boilers may be used at high altitude by using a certified field conversion kit, resulting in a 10% derate.

+ Heating Capacity based on D.O.E. (Department of Energy) test procedure

Add 5 1/2" to height when vent damper is used.

‡ 2 Section boilers are equipped with a 3' diameter flue collar on the draft diverter, and use a furnished 3"x4" increaser fitting to install the furnished 4" vent damper.

The Ratings marked "Net I=B=R Ratings" indicate the amount of equivalent direct radiation each boiler will take care of under normal conditions and thermostatic control. The Net I=B=R Ratings shown are based on an allowance of 1.15 in accordance with the factors shown on the I=B=R Standard as published by The Hydronics Institute.

Selection of boiler size should be based upon "Net I=B=R Rating" being equal to or greater than the calculated heat loss of the building.

The manufacturer should be consulted before selecting a boiler for installations having unusual piping and pickup requirements.

These boilers must stand on a non-combustible floor. If installed on a combustible floor, use Combustible Floor Base Number 42135-1 or 146-14-031 (2-6 section boilers) or 42135-2 or 146-14-032 (7-9 section boilers).

BOILERS FOR USE AT HIGH ALTITUDE

This boiler is factory equipped for use at altitudes of 0-2,000 feet above sea level. For use at altitudes above 2,000 feet above sea level, the input ratings are reduced by a change in main burner orifice size.

U.S.A. Only - For altitudes above 2,000 feet above sea level, input ratings should be reduced at the rate of 4% for each 1,000 feet above sea level. Consult the *National Fuel Gas Code* (NFPA54/ANSI Z223.1-latest edition), or the manufacturer for correct orifice sizing information. High altitude orifices are available from the boiler manufacturer.

Canada Only - For altitudes in the range of 2,000-4,500 feet above sea level, boilers may be field equipped for use at high altitude by using a certified field conversion kit. The change in main burner orifice size results in the boiler's input rating being reduced by 10%. The conversion shall be carried out by a manufacturer's authorized representative, in accordance with the requirements of the manufacturer, provincial or territorial authorities having jurisdiction and in accordance with the requirements of the CAN/CGA-B149.1 and CAN/CGA-B149.2 Installation Codes. The certified field conversion kit includes a conversion data plate, which must be attached to the boiler adjacent to the rating plate, indicating that the boiler has been converted for high altitude use. The conversion data plate must be filled in with the correct conversion information.

Before You Start

Check to be sure you have the right size boiler before starting the installation. See rating and capacity table on previous page. Also be sure the new boiler is for the type of gas you are using. Check the rating plate on the right side of the boiler.

You must see that the boiler is supplied with the correct type of gas, fresh air for combustion, and a suitable electrical supply. Also, the boiler must be connected to a suitable venting system and an adequate piping system. Finally, a thermostat, properly located, is needed for control of the heating system. If you have any doubts as to the various requirements, check with local authorities and obtain professional help where needed. Take the time to complete all of the steps for SAFE and PROPER operation of the heating system.

Where required by the authority having jurisdiction, the installation must conform to American Society of Mechanical Engineers Safety Code for Controls and Safety Devices for Automatically Fired Boilers, No. CSD-1.

The installation must conform to the requirements of the authority having jurisdiction or, in the absence of such requirements, to the National Fuel Gas Code, ANSI Z223.1-latest revision.

In Canada, the boiler shall be installed according to CAN/CGA-B149.1 and .2, Installation Code for Gas Burning Appliances and Equipment.

Installers – Follow local regulations with respect to installation of CO detectors. Follow maintenance recommendations in this instruction manual.

Techniciens – Veuillez vous conformer à la réglementation en vigueur concernant l'installation des détecteurs d'oxyde de carbone. Suivre les consignes d'entretien figurant dans le manuel d'instruction ci-joint.

KEEP BOILER AREA CLEAN AND FREE FROM COMBUSTIBLE MATERIALS, GASOLINE AND OTHER FLAMMABLE VAPORS AND LIQUIDS

Locating the Boiler

1. Select level location as centralized with piping system, and as near chimney, as possible.
2. Place crated boiler at selected location, remove crate by pulling crate sides from top and bottom boards. Combustible floors: When boiler is to be installed on a combustible floor, a Special Base Plate must be used – 42135-1 or 146-14-031 (2-6 Section), or 42135-2 or 146-14-032 (7-9 Section).

This boiler must not be installed on carpeting.

3. Boiler is to be level. Metal shims may be used under base legs for final leveling.
4. **Accessibility clearances must take precedence over fire protection clearances.** 18" clearance should be maintained at a side where passage is required to access to another side for cleaning or servicing, inspection, or replacement of any parts that normally may require such attention. 18" clearance is recommended on the control side for servicing.

Figure 2 shows minimum clearances to combustible construction. Rooms that are large in comparison with the size of the boiler are defined as rooms having a volume equal to or greater than 16 times the volume of the boiler. Where the actual ceiling height of a room is greater than 8', the volume of a room shall be figured on the basis of a ceiling height-of 8'. Determination of room size should be based on the total volume of all gas fired equipment installed in the room. Consult section 6.3.1 of the National Fuel Gas Code for further information, including approved methods for reducing clearances in large rooms.

5. Equipment shall be installed in a location in which the facilities for ventilation permit satisfactory combustion of gas, proper venting, and maintenance of ambient temperature at safe limits under normal conditions of use. Equipment shall be located so as not to interfere with proper circulation of air. When normal infiltration does not provide the necessary air, outside air shall be introduced (See Page 4 – "Fresh Air for Combustion").
6. Advise owner to keep air passages free of obstructions. Ventilating and combustion air must enter boiler room without restrictions.

7. The boiler shall be installed such that the automatic gas ignition system components are protected from water (dripping, spraying, rain, etc.) during appliance operation and service (circulator replacement, control replacement, etc.).

FIG. 2 - MINIMUM CLEARANCE DIMENSIONS

	Alcove, or Room Not Large in Comparison With Boiler		Room Large in Comparison With Boiler
	2-5 SECT.	6-9 SECT.	2-9 SECT.
Top	6"	6"	6"
Rear	6"	6"	6"
Control Side	8"	24"	6"
Opposite Side	6"	24"	6"
Front	18"	18"	18"
Flue/Vent Connector	6"	6"	6"
Near Boiler Piping	1"	1"	1"

Boiler Size	Boiler Volume (Cu. Ft.)	Minimum Room Volume Required To Be Large Room (Cu. Ft.) *
2 sect.	3.8	61.6
3 sect.	5.4	86.6
4 sect.	7.0	111.6
5 sect.	8.5	136.6
6 sect.	10.1	161.7
7 sect.	11.7	186.7
8 sect.	13.2	211.7
9 sect.	14.8	236.7

* FOR ROOM WITH SINGLE BOILER ONLY

THIS UNIT MUST BE SET ON A CONCRETE OR OTHER NON-COMBUSTIBLE MATERIAL BASE OR FLOOR.

Fresh Air for Combustion

Provision for combustion and ventilation air must be in accordance with Section 5.3, Air for Combustion and Ventilation, of the National Fuel Gas Code, ANSI Z223.1-latest revision, or applicable provisions of the local building codes.

WARNING

Be sure to provide enough fresh air for combustion. Enough air insures proper combustion and **assures that no hazard will develop due to the lack of oxygen.**

You must provide for enough fresh air to assure proper combustion. The fire in the boiler uses oxygen. It must have a continuous supply. The air in a house contains only enough oxygen to supply the burner for a short time. Outside air must enter the house to replace that used by the burner. Study following examples 1 and 2 to determine your fresh air requirements.

EXAMPLE 1: Boiler Located in Unconfined Space

If your boiler is in an open area (unpartitioned basement) in a conventional house, the air that leaks through the cracks around doors and windows will usually be adequate to provide air for combustion. The doors should not fit tightly. Do not caulk the cracks around the windows.

An unconfined space is defined as a space whose volume is not less than 50 cubic feet per 1,000 Btu per hour of the total input rating of all appliances installed in that space.

EXAMPLE 2: Boiler Located in Confined Space

A. **All Air from Inside the Building:** The confined space shall be provided with two permanent openings communicating directly with an additional room(s) of sufficient volume so that the combined volume of all spaces meets the criteria for an unconfined space. The total input of all gas utilization equipment installed in the combined space shall be considered in making this determination. Each opening shall have a minimum free area of one square inch per 1,000 Btu per hour of the total input rating of all gas utilization equipment in the confined space, but not less than 100 square inches. One opening shall be within 12 inches of the top and one within 12 inches of the bottom of the enclosure.

B. **All Air from Outdoors:** The confined space shall be provided with two permanent openings, one commencing within 12 inches of the top and one commencing within 12 inches of the bottom of the enclosure. The openings shall communicate directly, or by ducts, with the outdoors or spaces (crawl or attic) that freely communicate with the outdoors.

1. When directly communicating with the outdoors, each opening shall have a minimum free area of one square inch per 4,000 Btu per hour of total input rating of all equipment in the enclosure.

NOTE

If you use a fireplace or a kitchen or bathroom exhaust fan, you should install an outside air intake. These devices will rob the boiler and water heater of combustion air.

2. When communicating with the outdoors through vertical ducts, each opening shall have a minimum free area of one square inch per 4,000 Btu per hour of total input rating of all equipment in the enclosure.
3. When communicating with the outdoors through horizontal ducts, each opening shall have a minimum free area of one square inch per 2,000 Btu per hour of total input rating of all equipment in the enclosure.
4. When ducts are used, they shall be of the same cross-sectional area as the free area of the openings to which they connect. The minimum dimension of rectangular air ducts shall be not less than three inches.

FIG. 3 - FRESH AIR DUCT CAPACITIES

Fresh Air Duct Capacities for Ducts Supplying Fresh Air to boiler in tightly constructed houses. British Thermal Units per hour Input (Btuh)*.

Fresh Air Duct Size	¼" Mesh Screen Btuh	Wood Louvers Btuh	Metal Louvers Btuh
3' × 12"	144,000	36,000	108,000
8' × 8"	256,000	64,000	192,000
8' × 12"	384,000	96,000	288,000
8½' × 16"	512,000	128,000	384,000

*Based on opening covered by ¼" mesh screen, wood louvers, or metal louvers.

**FIG. 4
FRESH AIR DUCT FOR TIGHTLY SEALED HOUSE**

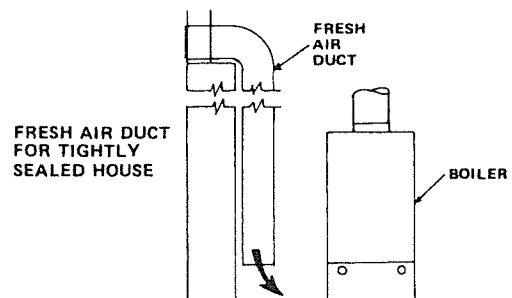

Installation - System Piping

1. Place boiler in the selected location (as near chimney as possible). Your boiler is shipped assembled. You need only to install the Relief Valve and a drain line to carry any water or steam to a drain.
2. Install Relief Valve into the $\frac{3}{4}$ " pipe on the top of the boiler. See Figure 5. Use $\frac{3}{4}$ " Pipe and an elbow (not furnished) to carry the water or steam to a nearby drain. Do not connect directly to a drain but leave an air gap. No shutoff of any description shall be placed between the safety relief valve and the boiler, or on discharge pipes between such safety valves and the atmosphere. Installation of the safety relief valve shall conform to the requirements of the ANSI/ASME Boiler and Pressure Vessel Code, Section IV. The manufacturer is not responsible for any water damage. Install Drain Valve in lower left side of boiler as marked.
3. Connect Supply and Return Lines to boiler. The connections may require certain additional fittings and parts, as shown on diagram (Figs. 5 and 6).
4. This boiler is equipped with $1\frac{1}{4}$ " supply and return connections on both the left and right sides of the boiler.

In connecting the cold water supply to the water inlet valve, make sure that a clean water supply is available. When the water supply is from a well or pump, a sand strainer should be installed at the pump.

A hot water boiler installed above radiation level must be equipped with a low water cutoff device. A periodic inspection is necessary, as is flushing of float type devices, per manufacturers specific instructions.

FOR USE WITH COOLING UNITS

- A. This boiler, when used in connection with chilled water systems, must be installed so that the chilled water is piped in parallel with the heating boiler. Appropriate valves must be used to prevent the chilled water from entering the heating boiler (Fig. 6).
- B. When this boiler is connected to heating coils located in air handling units where they may be exposed to refrigerated air circulation, the piping system shall be equipped with flow control valves or other automatic means to prevent gravity circulation of the boiler water during the cooling cycle.

LOW DESIGN WATER TEMPERATURE SYSTEMS (BELOW 140° F)

If the boiler is to be used in a heating system where design water temperatures

below 140° F are desired (e.g. radiant floor heating), a 3-way or 4-way mixing valve or suitable alternative is required to prevent low temperature return water from entering the boiler. Follow the mixing valve manufacturer's installation instructions.

The minimum design return water temperature to the boiler to prevent condensation in the boiler and venting is 120° F. The minimum high limit setting is 140° F.

FIG. 5 - TYPICAL HOT WATER PIPING

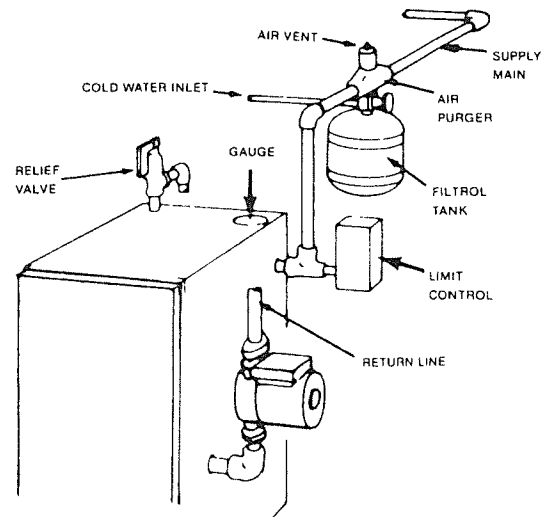
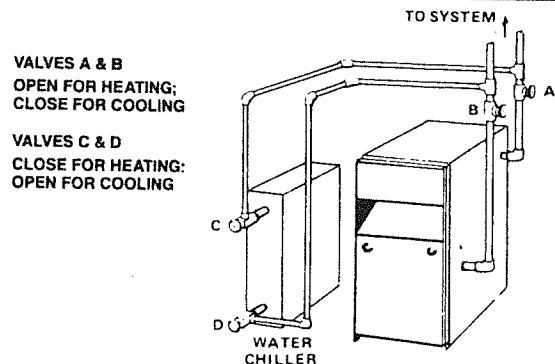

FIG. 6 - CHILLED WATER PIPING



Chimney and Vent Pipe Connection

For boilers for connection to gas vents or chimneys, vent installations shall be in accordance with Part 7, Venting of Equipment, of the National Fuel Gas Code, ANSI Z223.1-latest revision and applicable provisions of the local building codes.

CHECK YOUR CHIMNEY

This is a very important part of your heating system. It must be clean, the right size, properly constructed and in GOOD CONDITION. No boiler can function properly with a bad chimney. Fig. 7 gives typical chimney sizes. Fig. 8 gives you an idea how a boiler might be vented to a chimney. Note that the height (HT) is measured from the vent pipe to the top.

CHIMNEY SIZING

Chimney sizing, and all other aspects of the vent installation must be in accordance with Part 7 of the National Fuel Gas Code, ANSI Z223.1 - latest revision, and applicable provisions of the local building codes. In Canada, follow CAN/CGA B149.1 and B149.2, Installation Codes for Gas Burning Appliances and Equipment.



CONNECTING THE VENT DAMPER AND VENT CONNECTOR

Refer to Fig. 1 flue diagram for the size and location of the vent (flue opening). Use a 28 gauge (minimum) galvanized pipe to connect to the chimney.

IMPORTANT - The damper blade on the furnished vent damper has a ½ square inch hole (approximately ¾" diameter). On boilers equipped with standing pilot, the hole **must** be left open. On boilers equipped with intermittent ignition, the hole should be plugged by using the plug supplied with the vent damper.

1. Position furnished vent damper on top of flue outlet collar. Fasten damper securely to flue outlet collar with sheet metal screws. Make sure damper blade has clearance to operate inside of diverter.
On 2 section boilers equipped with vent damper, the supplied 4-inch vent damper is equipped with a 3- to 4-inch adapter so that the 4-inch vent damper may be installed on the boiler's 3-inch flue outlet collar. Fasten all fittings securely.

As An Option (U.S.A. Only)

The damper may be installed in any horizontal or vertical position, closer to the flue outlet collar preferred. Follow the diagrams - Figures 9, 10 and 11.

2. Install the vent damper to service only the single boiler for which it is intended. The damper position indicator shall be in a visible location following installation. Locate the damper so that it is accessible for servicing.
3. The damper must be in the open position when appliance main burners are operating.
4. The boiler is equipped with a factory wired harness that plugs into the vent damper.
5. Vent pipe must be same size as the flue outlet collar, except 2 section boilers with vent damper as noted above.
6. Slope pipe up from boiler to chimney not less than ¼" per foot.
7. Run pipe as directly as possible with as few elbows as possible.
8. Do not connect to fireplace flue.
9. End of vent pipe must be flush with inside face of chimney flue. Use a sealed-in thimble for the chimney connection.
10. Horizontal run should not be longer than ¾ the chimney height (HT) (Fig. 8).

The sections of vent pipe should be fastened with sheet metal screws to make the piping rigid. Horizontal portions of the vent system must be supported to prevent sagging. Use stovepipe wires every 5' to support the pipe from above. If the vent pipe must go through a crawl space, double wall vent pipe should be used. Where vent pipe passes through a combustible wall or partition, use a ventilated metal thimble. The thimble should be 4 inches larger in diameter than the vent pipe.

FIG. 7 - TYPICAL CHIMNEY SIZES

Boiler Input Btu/h	FLUE AREA IN INCHES		
	*HT. 10-15 Ft.	*HT. 15-25 Ft.	*HT. 25 Ft. Up
Up to 100,000	6 × 6	6 × 5	5 × 5
Up to 155,000	6 × 7	6 × 6	6 × 5
Up to 230,000	7 × 8	7 × 7	6 × 7
Up to 350,000	9 × 9	8 × 9	8 × 8

*HT = top of thimble to top of flue. See Fig. 8.

For boiler input refer to table, page 2.

For information only - not meant to imply minimum sizes.

MINIMUM VENT PIPE CLEARANCE

Wood and other combustible materials must not be closer than 6" from any surface of single wall metal vent pipe. Listed Type B vent pipe or other listed venting systems shall be installed in accordance with their listing.

REMOVING EXISTING BOILER FROM COMMON VENTING SYSTEM

When an existing boiler is removed from a common venting system, the common venting system is likely to be too large for proper venting of the appliances remaining connected to it.

At the time of removal of an existing boiler, the following steps shall be followed with each appliance remaining connected to the common venting system placed in operation, while the other appliances remaining connected to the common venting system are not in operation.

1. Seal any unused openings in the common venting system.
2. Visually inspect the venting system for proper size and horizontal pitch and determine there is no blockage or restriction, leakage, corrosion and other deficiencies which could cause an unsafe condition.
3. Insofar as is practical, close all building doors and windows and all doors between the space in which the appliances remaining connected to the common venting system are located and other spaces of the building. Turn on clothes dryers and any appliance not connected to the common venting system. Turn on any exhaust fans, such as range hoods and bathroom exhausts, so they will operate at maximum speed. Do not operate a summer exhaust fan. Close fireplace dampers.
4. Place in operation the appliance being inspected. Follow the lighting instructions. Adjust thermostat so appliance will operate continuously.
5. Test for spillage at the draft hood relief opening after 5 minutes of main burner operation. Use the flame of a match or candle, or smoke from a cigarette, cigar or pipe.
6. After it has been determined that each appliance remaining connected to the common venting system properly vents when tested as outlined above, return doors, windows, exhaust fans, fireplace dampers and any other gas-burning appliance to their previous conditions of use.

7. Any improper operation of the common venting system should be corrected so the installation conforms with the National Fuel Gas Code, ANSI Z223.1-latest revision. When resizing any portion of the common venting system, the common venting system should be resized to approach the minimum size as determined using the appropriate tables in Part 11 in the National Fuel Gas Code, ANSI Z223.1-latest revision.

For boilers for connection to gas vents or chimneys, vent installations shall be in accordance with Part 7, Venting of Equipment, of the National Fuel Gas Code, ANSI Z223.1-latest revision and applicable provisions of the local building codes.

Vent connectors serving appliances vented by natural draft shall not be connected into any portion of mechanical draft systems operating under positive pressure.

**FIG. 8
TYPICAL MASONRY CHIMNEY REQUIREMENTS**

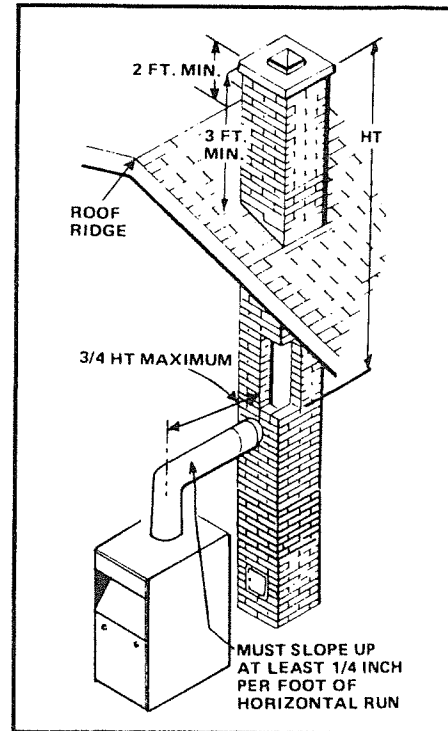

Vent Damper Operation

FIG. 9

HORIZONTAL INSTALLATION

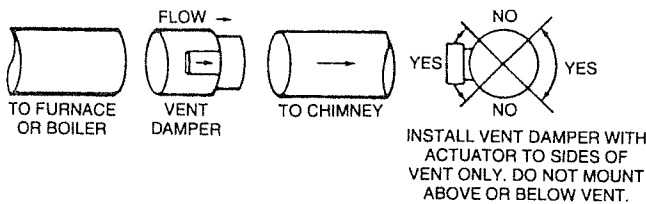

VERTICAL INSTALLATION

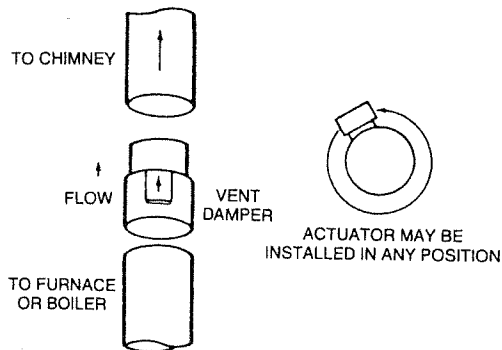
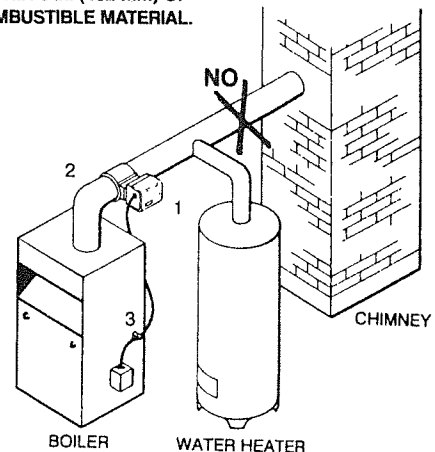

FIG. 10

CAUTION: DO NOT INSTALL THE VENT DAMPER WITHIN 6 in. (152 mm) OF COMBUSTIBLE MATERIAL.



TYPICAL INSTALLATION FOR VENT DAMPER NOTE CAUTION AND FOOTNOTES

1. Install the vent damper to service only the single appliance for which it is intended. If improperly installed, a hazardous condition, such as an explosion or carbon monoxide poisoning, could result.
2. Do not install the vent damper on vent pipe curve.
3. Do not run wires near high temperature surfaces. Use stand-off brackets if necessary.

For safe, efficient operation, the vent damper and all flue product carrying areas of the appliance must be checked annually by you, with particular attention given to deterioration from corrosion or other sources. If you see corrosion or other deterioration, contact your heating contractor for repairs. Check vent damper operation as follows:

1. When the boiler is off, check that the vent damper position indicator points to the closed position, Fig. 11.
2. Turn the thermostat or controller up to call for heat and check that the vent damper indicator points to the open position, Fig. 11.
3. Turn the thermostat or controller down again and check that the vent damper position indicator returns to the closed position.

MANUAL OPERATION OF THE VENT DAMPER

The Effikal vent damper may be placed in the open position to permit burner operation by using the "HOLD DAMPER OPEN" switch, located on the damper controller. The thermostat will control the burner firing as before, while the damper will remain open. **DO NOT** turn damper open manually or motor damage will result. Set switch to "AUTOMATIC OPERATION" to close vent damper during burner off cycle.

For further information, and for a vent damper troubleshooting guide, refer to the Effikal manual that was packaged with the vent damper.

The vent damper must be inspected at least once a year by a trained, experienced service technician. The name of the person who originally installed your vent damper is shown on the installation label.

**FIG. 11
EFFIKAL VENT DAMPER POSITION INDICATOR**

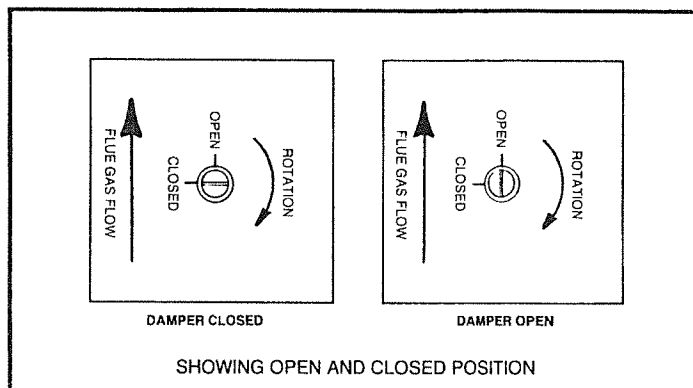

NOTES FOR CANADA ONLY

1. Canadian Standard CAN1-2.28-M81 prohibits the use of vent dampers on propane fired appliances equipped with intermittent ignition.
2. In Canada, the vent damper must be attached directly to the flue outlet collar, with the exception of the 2 section boiler, where the 3- to 4-inch adapter is supplied with the vent damper.

No other interconnecting pieces are allowed between the boiler and the vent damper.

3. In Canada, vent dampers are not an option. Boilers are either factory built for use with a vent damper and the vent damper is supplied with the boiler, or they are factory built for use without a vent damper. In the second case a vent damper cannot be installed later.

Gas Supply Piping

CHECK GAS SUPPLY

The gas pipe to your boiler must be the correct size for the length of the run and for the total BTU per hour input of all gas utilization equipment connected to it. See Fig. 12 for the proper size. Be sure your gas line complies with local codes and gas company requirements.

The boiler and its individual shutoff valve must be disconnected from the gas supply piping system during any pressure testing of that system at test pressures in excess of 1/2 psig (3.5 kPa).

The boiler must be isolated from the gas supply piping system by closing its individual manual shutoff valve during any pressure testing of the gas supply piping system at test pressures equal to or less than 1/2 psig (3.5 kPa).

CONNECTING THE GAS PIPING

Refer to Fig. 13 for the general layout at the boiler. It shows the basic fittings you will need. The gas line enters the boiler from the right side.

The following rules apply:

1. Use only those piping materials and joining methods listed as acceptable by the authority having jurisdiction, or in the absence of such requirements, by the National Fuel Gas Code, ANSI Z223.1-latest revision. In Canada, follow the CAN/CGA B149.1 and .2 Installation Codes for Gas Burning Appliances and Equipment.
2. Use pipe joint compound suitable for LP gas on male threads only.
3. Use ground joint unions.
4. Install a sediment trap upstream of gas controls.
5. Use two pipe wrenches when making the connection to the gas valve to keep it from turning.
6. Install a manual shut-off valve in vertical pipe about 5 feet above floor.
7. Tighten all joints securely.
8. Propane gas connections should only be made by a licensed propane installer.
9. Two-stage regulation should be used by the propane installer.
10. Propane gas piping should be checked out by the propane installer.

CHECKING THE GAS PIPING

Upon completion of piping, check immediately for gas leaks. Open the manual shut-off valve. Test for leaks by applying soap suds (or a liquid detergent) to each joint. Bubbles forming indicate a leak. CORRECT EVEN THE SMALLEST LEAK AT ONCE.

WARNING

Never use a match or open flame to test for leaks.

FIG. 12 - GAS PIPE SIZES

NATURAL GAS				
Length of Pipe - Ft.	Pipe Capacity - BTU Per Hour Input Includes Fittings			
	1/2"	3/4"	1"	1 1/4"
20	92,000	190,000	350,000	625,000
40	63,000	130,000	245,000	445,000
60	50,000	105,000	195,000	365,000

PROPANE GAS				
Length of Pipe - Ft.	Pipe Capacity - BTU Per Hour Input Includes Fittings			
	Copper Tubing*		Iron Pipe	
	5/8"	3/4"	1/2"	3/4"
20	131,000	216,000	189,000	393,000
40	90,000	145,000	129,000	267,000
60	72,000	121,000	103,000	217,000

*Outside diameter
The length of pipe or tubing should be measured from the gas meter or propane second stage regulator.

FIG. 13 - GAS PIPING AT BOILER

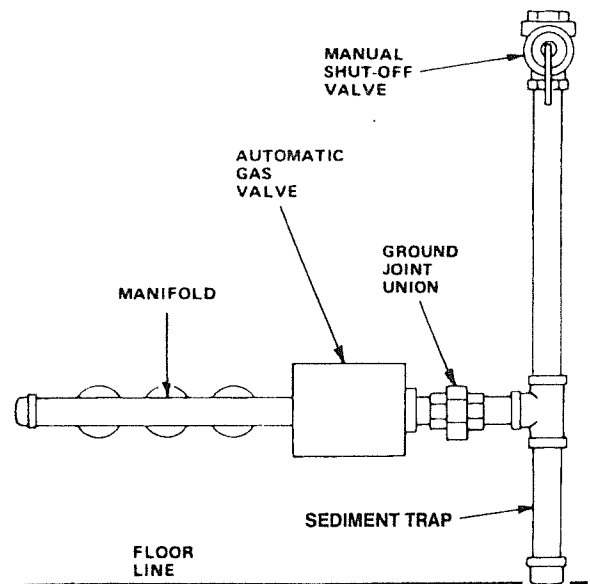

Electrical Wiring

All electrical work must conform to local codes as well as the National Electrical Code, ANSI/NFPA-70, latest revision. In Canada, electrical wiring shall comply with the Canadian Electrical Codes, CSA-C22.1 and .2.

ELECTRIC POWER SUPPLY

Run a separate 120 volt circuit from a separate overcurrent protective device in the electrical service entrance panel. This should be a 15 ampere circuit. Locate a shut-off switch at the boiler. It must be turned off during any maintenance. Connect 120 volt power supply to aquastat terminals L1 (HOT) and L2.

The boiler, when installed, must be electrically grounded in accordance with the requirements of the authority having jurisdiction or, in the absence of such requirements, with the National Electrical Code, ANSI/NFPA No. 70-latest revision. Run a 14 gauge or heavier copper wire from the boiler to a grounded connection in the service panel or a properly driven and electrically grounded ground rod.

WARNING

Turn off electric power at fuse box before making any line voltage connections. Follow local electrical codes.

INSTALL YOUR THERMOSTAT

The thermostat location has an important effect on the operation of your boiler system. **BE SURE TO FOLLOW THE INSTRUCTIONS INCLUDED WITH YOUR THERMOSTAT.**

Locate the thermostat about five feet above the floor on an inside wall. It may be mounted directly on the wall or on

a vertically mounted outlet box. It should be sensing average room temperature, so avoid the following:

DEAD SPOTS:

- Behind doors
- Corners and alcoves

HOT SPOTS:

- Concealed pipes
- Fireplace
- TV sets
- Radios
- Lamps
- Direct sunlight
- Kitchens

COLD SPOTS:

- Concealed pipes or ducts
- Stairwells - drafts
- Doors - drafts
- Unheated rooms on other side of wall

Set heat anticipator at .2 amps. 24 volt thermostat connects to aquastat terminals T and TV.

VENT DAMPER WIRING

The boiler is equipped with a factory wired harness with 4 pin molex plug, that plugs into a 4 pin molex receptacle inside the vent damper operator.

The vent damper must be connected for the boiler to operate.

Wiring diagrams follow for the various different models.

CAUTION

Label all wires prior to disconnection when servicing controls. Wiring errors can cause improper and dangerous operation. Verify proper operation after servicing.

WIRING DIAGRAMS FOR HOT WATER BOILERS

INTERMITTENT IGNITION

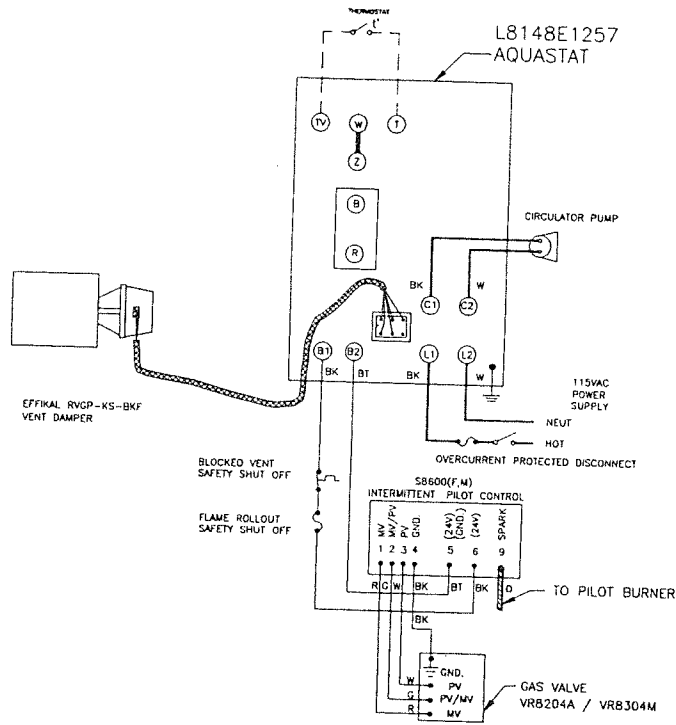

WIRE CODE

- DAMPER CABLE
- IGNITION CABLE
- LINE VOLTAGE
- LOW VOLTAGE
- LOW VOLTAGE FIELD WIRING

COLOR CODE

- BK-BLACK
- BR-BROWN
- O-ORANGE
- Y-YELLOW
- R-RED
- BT-BLACK WITH WHITE TRACER
- W-WHITE
- G-GREEN

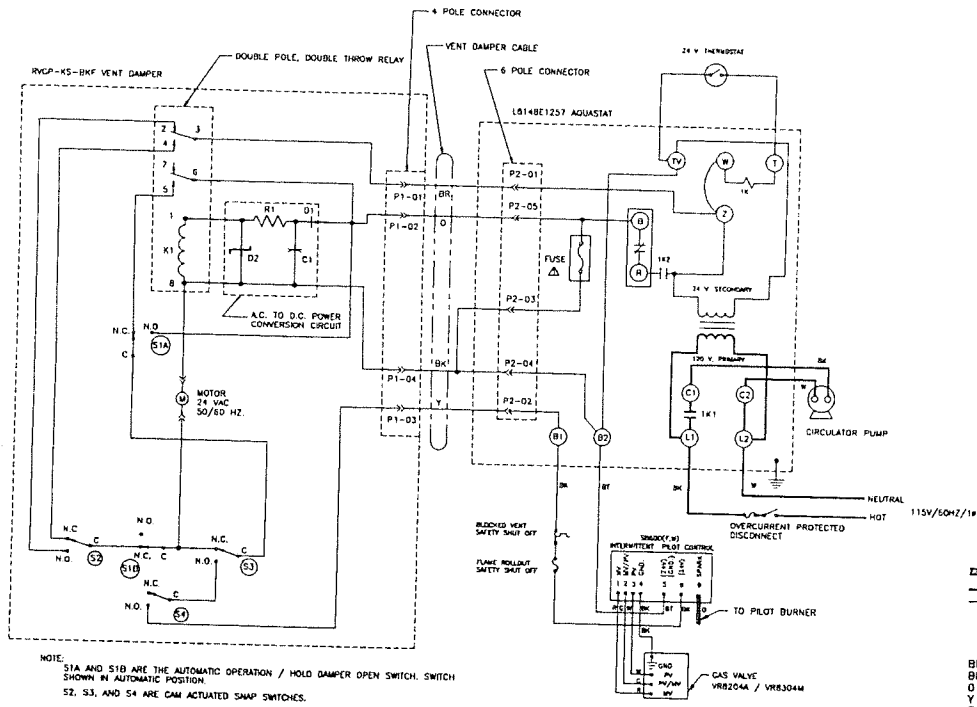

NOTE: S1A AND S1B ARE THE AUTOMATIC OPERATION / HOLD DAMPER OPEN SWITCH, SWITCH SHOWN IN AUTOMATIC POSITION.
S2, S3, AND S4 ARE CAM ACTUATED SNAP SWITCHES.
FUSE Δ BLOWS THE FIRST TIME THE THERMOSTAT CLOSSES AFTER THE VENT DAMPER IS PLUGGED IN. AFTER FUSE BLOWS, THE L8148E1257 WILL OPERATE THE BURNERS ONLY IF THE VENT DAMPER IS CONNECTED (PLUGGED IN).

WIRE CODE

- IGNITION CABLE
 - LINE VOLTAGE
 - LOW VOLTAGE
- ### COLOR CODE
- BK-BLACK
 - BR-BROWN
 - O-ORANGE
 - Y-YELLOW
 - R-RED
 - BT-BLACK WITH WHITE TRACER
 - W-WHITE
 - G-GREEN

IF ANY OF THE ORIGINAL WIRE AS SUPPLIED WITH THIS APPLIANCE MUST BE REPLACED, IT MUST BE REPLACED WITH TYPE 105° C THERMOPLASTIC WIRE OR ITS EQUIVALENT.

WIRING DIAGRAMS FOR HOT WATER BOILERS

STANDING PILOT

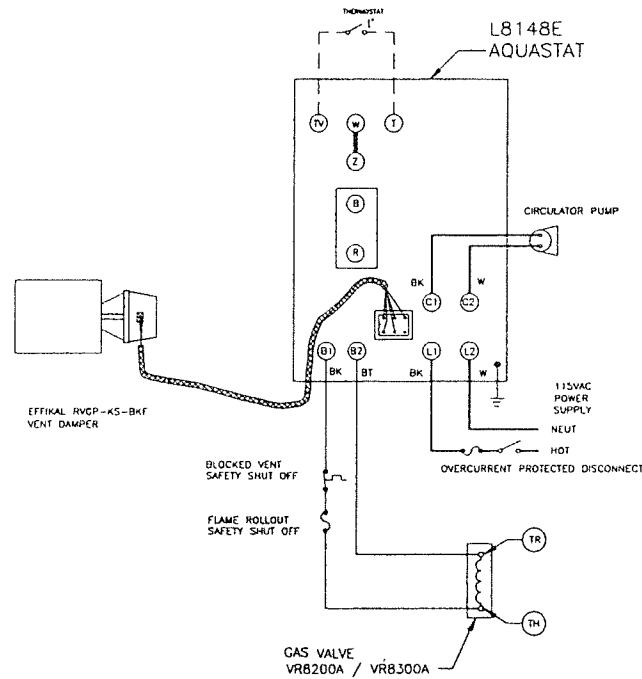

- WIRE CODE**
- DAMPER CABLE
 - IGNITION CABLE
 - LINE VOLTAGE
 - LOW VOLTAGE
 - LOW VOLTAGE
 - FIELD WIRING

- COLOR CODE**
- BK - BLACK
 - BR - BROWN
 - O - ORANGE
 - Y - YELLOW
 - R - RED
 - BT - BLACK WITH WHITE TRACER
 - W - WHITE
 - G - GREEN

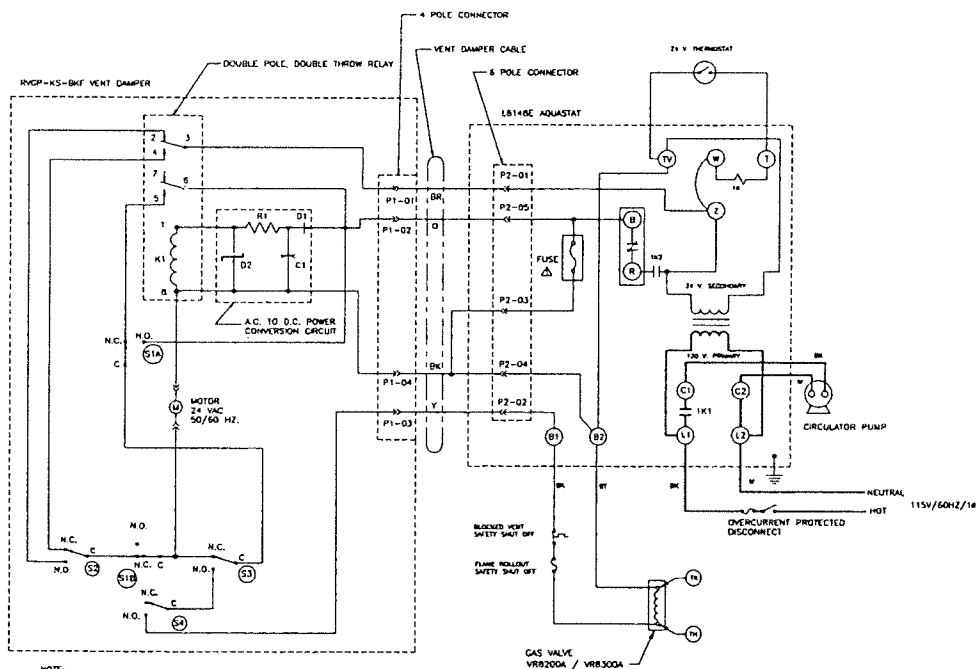

NOTE: S1A AND S1B ARE THE AUTOMATIC OPERATION / HOLD DAMPER OPEN SWITCH SHOWN IN AUTOMATIC POSITION.
 S2, S3, AND S4 ARE CAM ACTUATED SNAP SWITCHES.
 FUSE Δ BLOWS THE FIRST TIME THE THERMOSTAT CLOSURES AFTER THE VENT DAMPER IS PLUGGED IN. AFTER FUSE BLOWS, THE L8148E1257 WILL OPERATE THE BURNERS ONLY IF THE VENT DAMPER IS CONNECTED (PLUGGED IN).

- WIRE CODE**
- LINE VOLTAGE
 - LOW VOLTAGE

- COLOR CODE**
- BK - BLACK
 - BR - BROWN
 - O - ORANGE
 - Y - YELLOW
 - R - RED
 - BT - BLACK WITH WHITE TRACER
 - W - WHITE
 - G - GREEN

IF ANY OF THE ORIGINAL WIRE AS SUPPLIED WITH THIS APPLIANCE MUST BE REPLACED, IT MUST BE REPLACED WITH TYPE 105° C THERMOPLASTIC WIRE OR ITS EQUIVALENT.



Equipment and Optional Accessories - What They Do

RELIEF VALVE

You must have a relief valve on your boiler. Water expands as it is heated. If there is no place for the water to expand into, water pressure will build up inside the boiler and system. Should this happen, the relief valve will automatically open at a pre-determined pressure. This will relieve the strain on the boiler and system. Run a pipe from the relief valve outlet (pipe must be same size as outlet and the open end must not be threaded) to an open drain, tub or sink, or other suitable drainage point not subject to freezing. Failure to do so may cause water damage or injury should relief valve release.

EXPANSION TANK

In a properly assembled system, the expanding water flows into an expansion tank. This tank should be of the correct size.

The tank is filled with air. As the water expands it compresses the air in the tank to form an air pressure cushion. This "spring-like" cushion serves to maintain correct operating water pressure regardless of water temperature. This assures a "full measure" of water, even in the highest radiation unit of the system. It also prevents blowing off of the relief valve.

The air in the tank in the beginning (with system filled with cold water) is sufficient for proper operation. The tank also serves as a trap for excess air in the system. The air would cause gurgling in the pipes and inefficient circulation in the radiators if left in the system.

It is possible for a tank to become "water-logged" (filled with water). It can also become overfilled with air. This can happen after filling the system with new water. Fittings provided on the tank and in the line to the tank are for bleeding off excess water or air.

When installing this tank, it is important: 1) That the tank be higher than the boiler top. 2) That the pipe to the tank continuously rises up to the tank (so that air can "bubble" up to it).

DIAPHRAGM TYPE EXPANSION TANK

The diaphragm type expansion tank (EX-TROL) takes the place of the conventional expansion tank. Carefully read the instructions packed with your EX-TROL tank assembly.

The EX-TROL tank comes to you with a 10-12 pounds per square inch air charge. This is the same as the pressure produced in the system by the automatic fill valve. When the system is first filled, the EX-TROL tank will contain little or no water.

As the water is heated its pressure increases. It expands into the EX-TROL tank, compressing the air in the tank. This compressed air cushion permits the water in the system to expand as the temperature changes.

The diaphragm type tank can be mounted on the air purger fitting or at any other convenient place in the supply or return line.

AIR ELIMINATING FITTING (AIR PURGER)

An air purger is used to remove excess air from the system. It is installed in the supply line. It will eliminate air from the water before it reaches the radiators and bleed off this air.

MAIN AIR VENT FOR DOWN FLOW SYSTEMS OR DIAPHRAGM TYPE EXPANSION TANK

Before a system is filled with water, there is air in the pipes and radiation units. Some of it will be trapped as the system is filled. It is possible to eliminate most of this air through the air vents on the radiation units. A main air vent will speed and simplify this. It should be installed on the highest point in the supply main when all radiation is below top of boiler.

AUTOMATIC FILL VALVE

For safe, efficient operation, a hot water system must be **completely filled** with water. Adding new water, when needed can be done manually (by use of a hand valve in the water supply line). This requires regular attention to the system's needs. An automatic fill valve accomplishes this without attention. It is installed in the supply line on hot water boilers only. The valve operates through water pressure differentials. It does not require an electrical connection.

DRAIN VALVE

This manual valve provides a means of draining all water from the boiler and system. It is often installed in the $\frac{3}{4}$ " tapping at the bottom of the end boiler section. Or it can be installed in a tee where the return line enters the boiler.

WATER TEMPERATURE CONTROL

The water temperature limit control in the relay is adjustable and may be set as necessary. It may be set as low as 140° F., or as high as 240° F. This depends on the type and amount of radiation involved and weather conditions.

CIRCULATING PUMP

Every forced hot-water system requires a circulating pump. A separate pump or zone valve is required for each zone, if you have a two or more zone system. This pump must have the capacity to provide the circulation required by your system. The pump is connected into the return main just ahead of the boiler. It is also wired to the electrical system.

VENT DAMPER

This product is an automatic, motorized stack damper that has been developed to increase the efficiency of heating systems by reducing standby losses from the heating apparatus and the conditioned air space. The damper closes the chimney vent when the burner is off and fully opens it when combustion is required.

ROLLOUT SWITCH (FLAME ROLLOUT SAFETY SHUTOFF)

The rollout switch is a temperature-sensitive fuse link device. It is located on the boiler base just outside the fire box. In the event of heat exchanger flueway blockage causing flame to roll out of the fire box, the fuse will blow, shutting down the flow of gas to the main burners. The fuse does not change in appearance when blown.

If the rollout switch blows, it must be replaced with an exact replacement. Check heat exchanger flueways for blockage when restoring system to operating condition. Do not operate system without a rollout switch.

SPILL SWITCH (BLOCKED VENT SAFETY SHUTOFF)

The spill switch is a manual reset disc thermostat with a fixed setpoint (340°F), and normally closed contacts. It is located at the relief opening of the integral draft diverter. In the event of chimney or venting system blockage causing products of combustion to spill out of the relief opening, the spill switch disc heats up and the spill switch contacts will open, shutting down the flow of gas to the main burners by removing power to the gas valve.

In the event that the spill switch contacts open, the reset button on the back of the switch will pop up. The spill switch must be reset manually, after the switch has cooled off, by pushing the reset button down. Check the venting system and chimney for blockage when restoring the system to operating condition. DO NOT operate the boiler without a spill switch.

Starting Your Boiler

HOW A HOT-WATER SYSTEM OPERATES

Your entire heating system (boiler, piping and radiation units) is filled with water. As the water in the boiler is heated, it is pumped from the top of the boiler through the supply main to the radiation units. The cooler water in them flows back through the return main to the boiler. This provides positive and rapid response to the thermostat.

FILLING SYSTEM WITH WATER

Close the air vents on all radiation units. Open the valves to these units. Make sure the boiler and expansion tank drain cocks are closed. The air bleed screw on the tank drain fitting should be closed. Open the valve in the line from the boiler to the expansion tank (see page 17 for additional information). Open the water inlet to your boiler and leave it open. Start with the **lowest** radiation unit. Open the air vent on this unit. When all the air has escaped and water

starts to flow from the vent, close it. Go to the next radiation unit, and repeat this process. Repeat until you have covered every radiation unit in the system (ending up at the highest unit in the system). If your units have automatic vents, this manual venting is unnecessary but it will speed up the proper filling of your system.

If your system is a closed expansion tank system, you may have an Automatic Fill Valve. You may leave it open to refill the system automatically as needed. Check the temperature-pressure gauge. Not the position of the hand indicating pressure. This should be between 10 and 15 lbs. Any lowering of this movable hand below 10 lbs. will indicate loss of water due to leakage. The automatic fill valve should compensate for this. Instructions are packaged with the valve.

WARNING – Never run water into a hot empty boiler.

For Your Safety Read Before Operating

WARNING: If you do not follow these instructions exactly, a fire or explosion may result causing property damage, personal injury or loss of life.

- A. Some boilers are equipped with an intermittent ignition device which automatically lights the pilot. Do **not** try to light the pilot by hand.
Some boilers are equipped with a continuous pilot and must be manually lighted. (See lighting instructions on page 15.) A match holder is included in the parts bag.
- B. BEFORE OPERATING smell all around the appliance area for gas. Be sure to smell next to the floor because some gas is heavier than air and will settle on the floor.
- WHAT TO DO IF YOU SMELL GAS
- Do not try to light any appliance.
 - Do not touch any electric switch; do not use any phone in your building.
 - Immediately call your gas supplier from a neighbor's phone. Follow the gas supplier's instructions.
 - If you cannot reach your gas supplier, call the fire department.
- C. Use only your hand to push in or turn the gas control knob. Never use tools. If the knob will not push in or turn by hand, don't try to repair it, call a qualified service technician. Force or attempted repair may result in a fire or explosion.
- D. Do not use this appliance if any part has been under water. Immediately call a qualified service technician to inspect the appliance and to replace any part of the control system and any gas control which has been under water.

Intermittent Ignition Boiler – VR8204A/VR8304M Gas Valve Operating Instructions

1. STOP! Read the safety information on page 14.
2. Set the thermostat to lowest setting.
3. Turn off all electric power to the appliance.
4. This appliance is equipped with an ignition device which automatically lights the pilot. Do **not** try to light the pilot by hand.
7. Wait five (5) minutes to clear out any gas. Then smell for gas, including near the floor. If you smell gas, STOP! Follow "B" in the safety information on page 14. If you don't smell gas, go to next step.
8. Rotate the gas control knob counterclockwise to "ON."
9. Replace lower front panel.
10. Turn on all electric power to the appliance.
11. Set thermostat to desired setting.
12. If the appliance will not operate, follow the instructions "To Turn Off Gas To Appliance" and call your service technician or gas supplier.

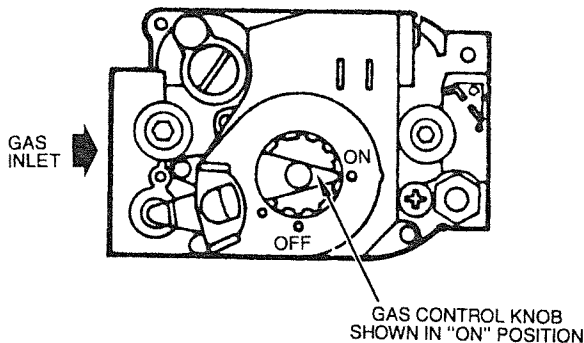

5. Remove lower front panel.
6. Rotate the gas control knob clockwise to "OFF."
1. Set the thermostat to lowest setting.
2. Turn off all electric power to the appliance if service is to be performed.
3. Push in gas control knob slightly and turn clockwise to "OFF." Do not force.

TO TURN OFF GAS TO APPLIANCE

Continuous Pilot Boiler – VR8200A/VR8300A Gas Valve Operating Instructions

1. STOP! Read the safety information on page 14.
2. Set the thermostat to lowest setting.
3. Turn off all electric power to the appliance.
4. Remove lower front panel.
5. Rotate gas control knob slightly and turn clockwise to "OFF."

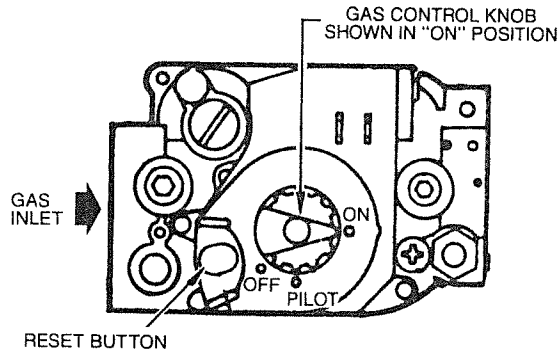

6. Wait five (5) minutes to clear out any gas. Then smell for gas, including near the floor. If you smell gas, STOP! Follow "B" in the safety information on page 14. If you don't smell gas, go to next step.
7. Find pilot – follow metal tube from gas control. The pilot is between two burner tubes as shown in Fig. 14.
8. Turn knob on gas control counterclockwise to "PILOT."

9. Rotate the gas control knob counterclockwise to "PILOT." Push down and hold the red reset button while you light pilot burner with a match.

After about one minute, release reset button. Pilot should remain lit. If it goes out, turn gas control knob clockwise to OFF. To relight, repeat steps 5-9.

- If button does not pop up when released, stop and immediately call your service technician or gas supplier.
 - If the pilot will not stay lit after several tries, turn the gas control knob to "OFF" and call your service technician or gas supplier.
10. After pilot remains lit when red reset button is released, turn gas control knob counterclockwise to "ON."
 11. Replace lower front panel.
 12. Turn on all electric power to the appliance.
 13. Set thermostat to desired setting.

TO TURN OFF GAS TO APPLIANCE

1. Set the thermostat to lowest setting.
2. Turn off all electric power to the appliance if service is to be performed.
3. Push in gas control knob slightly and turn clockwise to "OFF." Do not force.

Operating Your Boiler

AUTOMATIC GAS VALVE

The Automatic Gas Valve opens or closes according to the heat requirements of the thermostat and temperature limit control. It closes if the pilot goes out. Each individual control must be operating correctly before any gas can pass to the burners. Any one control can hold the gas supply from burner regardless of the demand of any other control.

SAFETY PILOT

Safety Pilot prevents the flow of gas to burner if the pilot goes out, or will not ignite.

GAS VALVE SAFETY SHUTDOWN TEST

1. For boilers equipped with continuous pilot, with main burners firing, disconnect the thermocouple from the gas valve. The gas valve should immediately shut off the main burners and the pilot.
2. For boilers equipped with intermittent ignition, with main burners firing, disconnect the ignition cable from the intermittent pilot control box. The gas valve should shut off the main burners. TURN OFF ELECTRIC POWER to boiler before reconnecting ignition cable, to prevent electric shock.

RELIGHT

The electric and gas shall be off for 5 minutes before relighting.

THERMOSTAT

Keep it set at a desired room temperature. If windows are to be opened or heat is not needed, move thermostat pointer to a lower setting.

NOTE

In the event of failure of any component, the system will not operate or will go into safety lockout. The system is completely self-checking. On every call for heat, each component must be functioning properly to permit operation. On safety lockout the system has to be reset by turning the thermostat to the lowest setting for one minute, then back to the normal setting.

Safe lighting and other performance criteria were met with the gas manifold and control assembly provided on the boiler when the boiler underwent tests specified in ANSI Z21.13 – latest revision.

FIG. 14 - LIGHTING PILOT

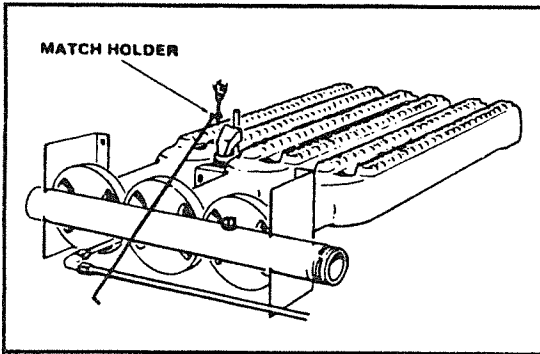

FIG. 15 - VR8200A VR8300A AUTOMATIC GAS VALVE

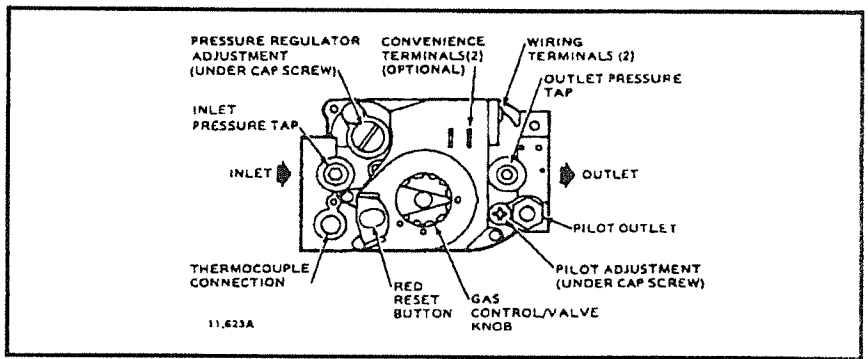

FIG. 16 - VR8204A/VR8304M AUTOMATIC GAS VALVE

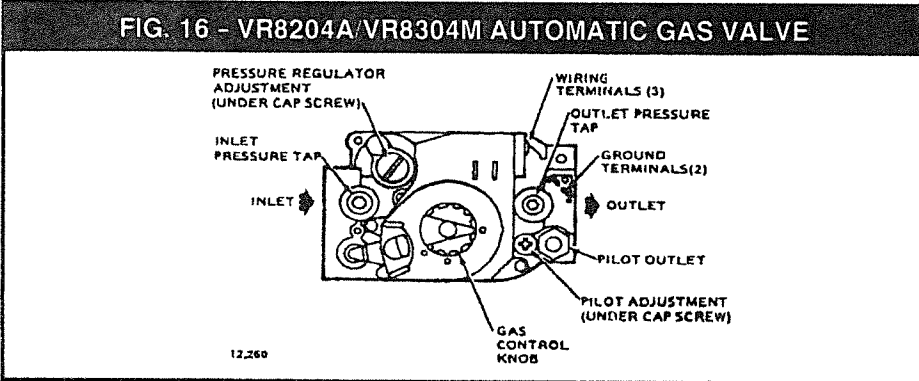
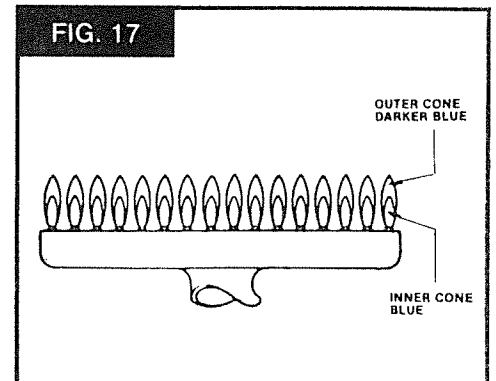

FIG. 17



Checking and Adjusting

ADJUST PILOT BURNER

Pilot flame should surround 3/8" to 1/2" of the pilot sensor. Refer to Fig. 18. If flame needs adjusting, do it as follows:

1. Remove screw cover over pilot adjusting screw.
2. Insert small screwdriver and adjust flame as needed. Turn screw counterclockwise to increase flame, clockwise to decrease.
3. Replace screw cover over pilot adjusting screw.

MAIN BURNER AIR ADJUSTMENT

The primary air shutters on the cast iron main burners should be adjusted so the flame forms a sharp blue cone with no yellow. Refer to Fig. 17. It may be necessary to remove the rollout shield to observe main burner flames. Replace after adjustment of air shutters.

The stainless steel main burners (Propane Gas Boilers) do not require primary air adjustment.

ADJUST LIMIT CONTROLS

Instructions for each control are included with the controls.

RECOMMENDED BOILER WATER TEMPERATURES

Type of Heating Unit	Limit Control Setting
Standing Radiators	180° F.
Baseboard and Convector Radiators	200° F.

These settings can be changed after you have had some idea how the system works. Example: If your system does

not give quite enough heat in very cold weather, you can raise the limit setting to 220° F. Use the boiler gauge to check your settings. Make the adjustments according to its readings. Check thermostat operation. When set above temperature indicated on the thermometer, boiler should ignite. Make certain the thermostat turns off the boiler when room temperature reaches the selected setting and starts the boiler operating when room temperature falls a few degrees.

After setting limit control to limit setting, check to see if it shuts off the gas supply to the burners. Turn your thermostat up to call for heat and let your boiler run until the temperature of the water reaches the limit setting. The gas valve should shut off and the circulator keep running until the thermostat is satisfied, or the water cools enough to restart the burners through the limit control.

Finally, set the thermostat for the desired temperature. Special conditions in your home and the location of the thermostat will govern this setting.

FIG. 18

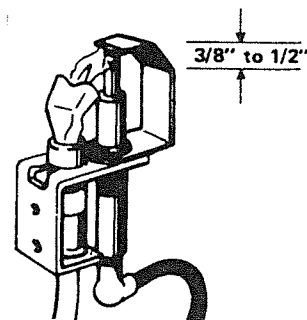

Maintaining Your Boiler

BURNERS

A visual check of the pilot and main burner flames should be made at least once each year, preferably at the beginning of the heating season. See page 16.

RELIEF VALVE

This valve should open automatically if the system pressure exceeds the pressure rating (usually 30 psi) of the relief valve. Should it ever fail to open under this condition, shut down your system. Drain the system until system pressure is reduced below the relief valve pressure rating. If valve discharge occurs, or if valve fails to open as described above, contact an authorized contractor or qualified service technician to replace the relief valve and inspect the heating system to determine the cause, as this may indicate an equipment malfunction.

This valve should be tested every month during periods of boiler operation, and at the beginning and end of any extended non-service period. Prior to testing, make certain discharge pipe is properly connected to valve outlet and arranged so as to contain and safely dispose of boiler discharge. Test at normal system operating pressure. Hold the trip lever fully open for at least five seconds in order to flush free any sediment that may lodge on the valve seat. Then permit the valve to snap shut.

EXPANSION TANK

As previously noted, this tank may become waterlogged, or may receive an excess of air. Frequent automatic opening of the relief valve indicates water logging. A high boiler temperature accompanied by unusually low radiation unit temperature (and "knocking") indicates excess air in tank.

To correct either condition, close the valve between the boiler and the tank. Drain the tank until it is empty. Check all the tank plugs and fittings. Tighten as necessary. Open the valve between the boiler and tank. Water will rise to the normal height in the tank if you have an automatic fill valve (otherwise, manually refill the system).

BOILER FLUE PASSAGES

Under normal operating conditions, with the burners properly adjusted, it should not be necessary to clean the boiler flue gas passages. However, to assure trouble-free operation, we recommend that you have the flue passages, burner adjustment, and operation of the controls checked *once each year* by a competent Service Technician.

Before the start of each season (or whenever system has been shut down for some time) recheck the whole system for leaks . . . and recheck the boiler and vent pipe for leaks. Replace or patch any boiler seals that are faulty.

VENT PIPE

The venting of this unit is very important and the piping should be checked at least once a season. If the vent piping shows any sign of leaking, replace it immediately.

WATER SYSTEM

If system is to remain out of service during freezing weather, always **drain it** completely (water left in to freeze will crack the pipes and/or boiler).

CLEANING YOUR BOILER AND BURNERS

Flue passages between sections should be examined yearly and cleaned if necessary. To clean, remove burners, pilot, and vent pipe. Remove top and front jacket panels. Remove the two screws attaching the intermediate front panel to the left and right side jacket panels. Remove the draft diverter and intermediate front panel as a unit. Carefully remove the cerafelt gasket strips. Clean passageways between sections with a flexible handle wire brush. Remove dirt from bottom of boiler and from between sections by vacuuming. Make sure all flame ports in burners are open and clear. Shake out or blow out all loose dirt in burners. Reseal seams between adjacent sections as necessary with 400 F RTV silicone sealant. Reassemble all parts. Be sure to check tightness of pilot connections and condition of burner flames after reassembly (see Figures 17 and 18). Be sure vent pipe connections to chimney are secure and no obstructions are present.

Service Hints

You may avoid inconvenience and service calls by checking these points before you call for service.

FOR YOUR SAFETY
WHAT TO DO IF YOU SMELL GAS

1. Do Not try to light any appliance.
2. Do not touch any electric switch, do not use the phone.
3. Leave the building immediately, then call your gas supplier.
4. If you cannot reach the gas supplier, call the fire department.

IF YOUR SYSTEM IS NOT HEATING OR NOT GIVING ENOUGH HEAT

Possible Cause	What to do
Thermostat is not set correctly	Reset thermostat above room temperature.
Burner is not operating properly	Check flame. If it is yellow, the burner is not getting enough air. Or, if flame is blue and noisy and seems to lift off the burner, the burner is getting too much air. Contact your service technician.
No electric power to boiler	Check overcurrent protection. Check to be sure electric power supply circuit is "ON."
Controls out of adjustment	Reset according to instructions.
Radiators not heating	Open radiator vents to vent excess air. Check flow control valve (if used). It may be in closed position.
Circulating pump not running	Check overcurrent protection. Check relay operation.
Poor electrical contact	Check all control terminals and wire joints.
Rollout switch blown	Have your service technician check heat exchanger for blockage. Replace rollout switch with exact replacement.
Spill switch blown	Have your service technician check venting system and chimney for blockage, or down draft condition. Reset spill switch.
Vent damper not operating	Consult troubleshooting guide in Effikal manual, packaged with vent damper.

IF BURNER IS NOISY

Possible Cause	What to do
Gas input amount is incorrect	Contact your service technician.

RELIEF VALVE LEAKING

Possible Cause	What to do
Dirt on seat	Open valve manually. Allow water to run and clear valve seat.
Water logged expansion tank	Drain tank, see instructions.

HAVE YOUR SERVICE TECHNICIAN CHECK ANY PROBLEM YOU ARE UNABLE TO CORRECT.

Repair Parts

GAS-FIRED HOT WATER BOILERS

— IMPORTANT —

READ THESE INSTRUCTIONS BEFORE ORDERING

All parts listed in the following Parts List may be ordered through your nearest supplier.

When ordering parts, first obtain the Model Number from the data plate on your boiler, then determine the Part No. (not the Key No.) and the Description of each part from the following illustrations and list. Be sure to give us all this information:

The Part No. - The Part Description - The Boiler Model No.

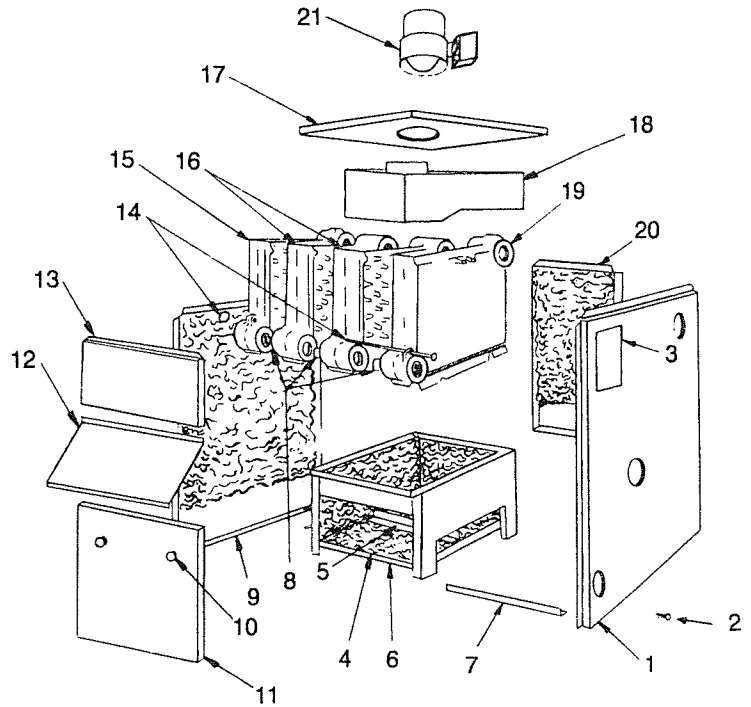

JACKET - SECTION AND BASE PARTS

THIS IS A REPAIR PARTS LIST - NOT A PACKING LIST

KEY NO.	DESCRIPTION	NATURAL GAS								
		2 SECTION	3 SECTION	4 SECTION	5 SECTION	6 SECTION	7 SECTION	8 SECTION	9 SECTION	
		Part No.	Part No.	Part No.	Part No.	Part No.	Part No.	Part No.	Part No.	
1	Jacket, Right Side Panel	425-00-901	425-00-901	425-00-901	425-00-901	425-00-901	425-00-901	425-00-901	425-00-901	425-00-901
2	#10 × 1/2" Sheet Metal Screw	146-95-074	146-95-074	146-95-074	146-95-074	146-95-074	146-95-074	146-95-074	146-95-074	146-95-074
3	Rating Plate	146-94-016	146-94-016	146-94-016	146-94-016	146-94-016	146-94-016	146-94-016	146-94-016	146-94-016
4	Base Insulation - Base Sides (2) - Base Front - Base Rear	146-14-020	146-14-130	146-14-130	146-14-130	146-14-130	146-14-130	146-14-130	146-14-130	146-14-130
		146-14-112	146-14-113	146-14-114	146-14-115	146-14-116	146-14-117	146-14-118	146-14-119	146-14-120
		146-14-122	146-14-123	146-14-124	146-14-125	146-14-126	146-14-127	146-14-128	146-14-129	146-14-130
5	Base Baffle	425-00-642	425-00-643	425-00-644	425-00-645	425-00-646	425-00-647	425-00-648	425-00-649	
6	Base	425-00-662	425-00-663	425-00-664	425-00-665	425-00-666	425-00-667	425-00-668	425-00-669	
7	Jacket Tie Bar	425-00-652	425-00-653	425-00-654	425-00-655	425-00-656	425-00-657	425-00-658	425-00-659	
8	Push Nipple	433-00-976	433-00-976	433-00-976	433-00-976	433-00-976	433-00-976	433-00-976	433-00-976	
9	Jacket, Left Side Panel	425-00-900	425-00-900	425-00-900	425-00-900	425-00-900	425-00-900	425-00-900	425-00-900	
10	Knob, Service Door (pair)	137-02-153	137-02-153	137-02-153	137-02-153	137-02-153	137-02-153	137-02-153	137-02-153	
11	Jacket Service Door	425-00-912	425-00-913	425-00-914	425-00-915	425-00-916	425-00-917	425-00-918	425-00-919	
12	Jacket Intermediate Panel	425-00-812	425-00-813	425-00-814	425-00-815	425-00-816	425-00-817	425-00-818	425-00-819	
13	Jacket Front Panel	425-00-810	425-00-811	425-00-804	425-00-805	425-00-806	425-00-807	425-00-808	425-00-809	
14	1/4" Tie Rod and Nut	146-05-008	146-05-001	146-05-002	146-05-051	146-05-053	146-05-005	146-05-007	146-05-009	
15	Boiler Section, Left End	410-00-020	410-00-020	410-00-020	410-00-020	410-00-020	410-00-020	410-00-020	410-00-020	
16	Boiler Section, Middle	410-00-022	410-00-022	410-00-022	410-00-022	410-00-022	410-00-022	410-00-022	410-00-022	
17	Jacket Top Panel	425-00-842	425-00-843	425-00-844	425-00-845	425-00-846	425-00-847	425-00-848	425-00-849	
18	Draft Diverter	425-00-672	425-00-673	425-00-674	425-00-675	425-00-676	425-00-677	425-00-678	425-00-679	
19	Boiler Section, Right End	410-00-021	410-00-021	410-00-021	410-00-021	410-00-021	410-00-021	410-00-021	410-00-021	
20	Jacket Back Panel	425-00-902	425-00-903	425-00-904	425-00-905	425-00-906	425-00-907	425-00-908	425-00-909	
‡	Jacket Complete	425-00-922	425-00-923	425-00-924	425-00-925	425-00-926	425-00-927	425-00-928	425-00-929	
‡	Block Assembly (19, 16, 15, 14, 8)	410-00-213	410-00-313	410-00-413	410-00-513	410-00-613	410-00-713	410-00-813	410-00-913	
‡	Combustible Floor Plate	146-14-031	146-14-031	146-14-031	146-14-031	146-14-031	146-14-032	146-14-032	146-14-032	
‡	Cerafelt Gasket	146-14-018	146-14-018	146-14-018	146-14-018	146-14-018	146-14-018	146-14-018	146-14-018	
21	Vent Damper	146-28-011	146-28-001	146-28-002	146-28-002	146-28-003	146-28-003	146-28-003	146-28-003	
‡	Base Assembly (4, 5, 6)	433-00-662	433-00-663	433-00-664	433-00-665	433-00-666	433-00-667	433-00-668	433-00-669	

‡Not Illustrated.

Repair Parts

FOR USE WITH NATURAL GAS ONLY

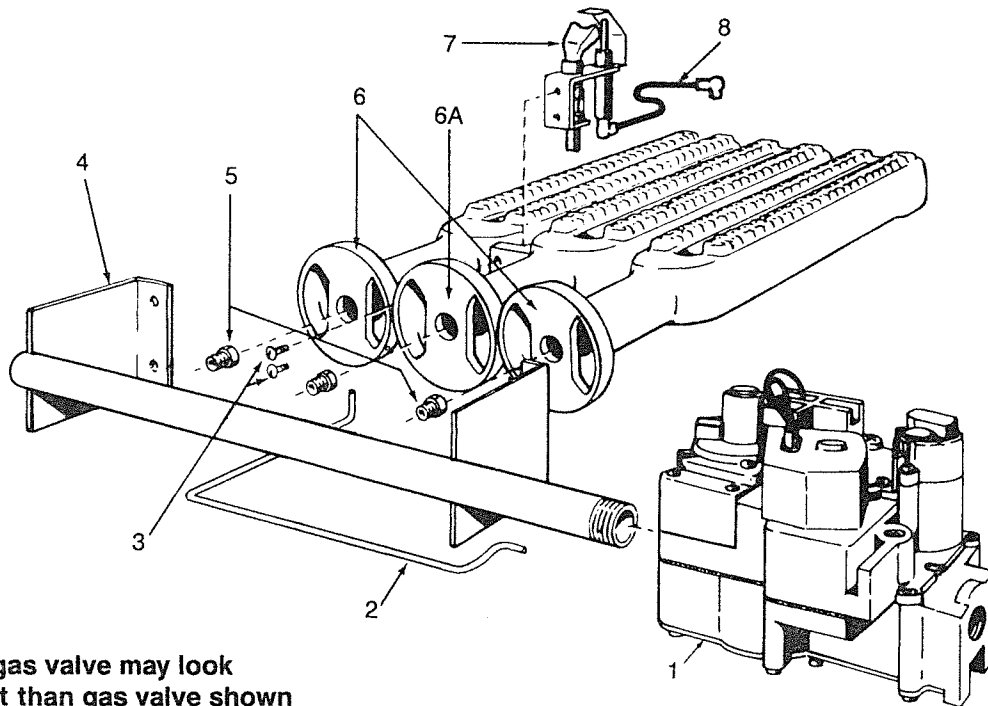

NOTE: Actual gas valve may look different than gas valve shown

GAS BURNERS AND MANIFOLD PARTS

THIS IS A REPAIR PARTS LIST - NOT A PACKING LIST

ELECTRONIC INTERMITTENT IGNITION (Shown)

KEY NO.	DESCRIPTION	2 SECTION	3 SECTION	4 SECTION	5 SECTION	6 SECTION	7 SECTION	8 SECTION	9 SECTION
		Part No.	Part No.	Part No.	Part No.	Part No.	Part No.	Part No.	Part No.
1	24 Volt Gas Valve, Elect. Int. Ign.	146-62-052	146-62-052	146-62-052	146-62-052	146-62-058	146-62-058	146-62-058	146-62-058
2	Pilot Tube	146-15-005	146-15-005	146-15-005	146-15-005	146-15-005	146-15-005	146-15-006	146-15-006
3	10-32 x 1/2" Hex Head Screw (2 req'd.)	146-95-307	146-95-307	146-95-307	146-95-307	146-95-307	146-95-307	146-95-307	146-95-307
4	Gas Manifold	146-16-032	146-16-033	146-16-034	146-16-035	146-16-013	146-16-014	146-16-015	146-16-016
5	Main Burner Orifice*	146-15-031	146-15-031	146-15-031	146-15-031	146-15-035	146-15-035	146-15-035	146-15-035
6	Main Burner**	—	146-15-523	146-15-523	146-15-523	146-15-523	146-15-523	146-15-523	146-15-523
6A	Main Burner with Pilot Bracket	146-15-522	146-15-522	146-15-522	146-15-522	146-15-522	146-15-522	146-15-522	146-15-522
7	Pilot Burner	146-62-054	146-62-054	146-62-054	146-62-054	146-62-054	146-62-054	146-62-054	146-62-054
8	Ignition Cable	146-62-074	146-62-074	146-62-074	146-62-074	146-62-075	146-62-075	146-62-075	146-62-075
‡	Air Shutter Springs (1 per Burner)	146-34-061	146-34-061	146-34-061	146-34-061	146-34-061	146-34-061	146-34-061	146-34-061
‡	Air Shutters (1 per Burner)	425-00-418	425-00-418	425-00-418	425-00-418	425-00-418	425-00-418	425-00-418	425-00-418
‡	Rollout Shield	425-00-932	425-00-933	425-00-934	425-00-935	425-00-936	425-00-937	425-00-938	425-00-939

ALTERNATE PARTS FOR CONTINUOUS PILOT - 24 VOLT

1	24 Volt Gas Valve, Continuous Pilot	146-62-051	146-62-051	146-62-051	146-62-051	146-62-060	146-62-060	146-62-060	146-62-060
7	Pilot Burner	146-62-053	146-62-053	146-62-053	146-62-053	146-62-053	146-62-053	146-62-053	146-62-053
8	Thermocouple	146-62-037	146-62-037	146-62-039	146-62-039	146-62-039	146-62-039	146-62-036	146-62-036

Quantity is 1 unless otherwise noted.

* Requires 1 less than the number of sections.

** Requires 2 less than the number of sections.

‡ Not Illustrated.

Repair Parts

FOR USE WITH PROPANE GAS ONLY

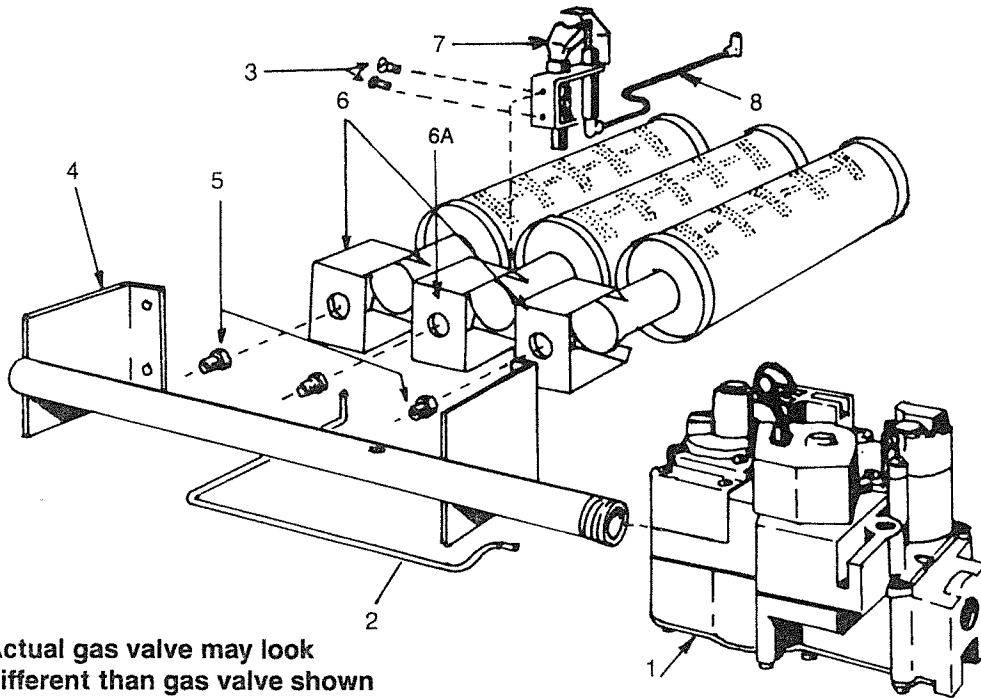

NOTE: Actual gas valve may look different than gas valve shown

PROPANE GAS BURNERS AND MANIFOLD PARTS

THIS IS A REPAIR PARTS LIST - NOT A PACKING LIST

ELECTRONIC INTERMITTENT IGNITION (Shown)

KEY NO.	DESCRIPTION	2 SECTION	3 SECTION	4 SECTION	5 SECTION	6 SECTION	7 SECTION	8 SECTION	9 SECTION
		Part No.	Part No.	Part No.	Part No.	Part No.	Part No.	Part No.	Part No.
1	24 Volt Gas Valve, Elect. Int. Ign.	146-62-062	146-62-062	146-62-062	146-62-062	146-62-059	146-62-059	146-62-059	146-62-059
2	Pilot Tube	146-15-005	146-15-005	146-15-005	146-15-005	146-15-005	146-15-005	146-15-006	146-15-006
3	10-32 × 3/16" Hex Head Screw (2 req'd.)	146-95-301	146-95-301	146-95-301	146-95-301	146-95-301	146-95-301	146-95-301	146-95-301
4	Gas Manifold	146-16-009	146-16-010	146-16-011	146-16-012	146-16-013	146-16-014	146-16-015	146-16-016
5	Main Burner Orifice*	146-15-036	146-15-036	146-15-036	146-15-036	146-15-036	146-15-036	146-15-036	146-15-036
6	Main Burner less Pilot Bracket**	---	146-15-528	146-15-528	146-15-528	146-15-528	146-15-528	146-15-528	146-15-528
6A	Main Burner with Pilot Bracket	146-15-529	146-15-529	146-15-529	146-15-529	146-15-529	146-15-529	146-15-529	146-15-529
7	Pilot Burner	146-62-038	146-62-056	146-62-056	146-62-056	146-62-056	146-62-056	146-62-056	146-62-056
8	Ignition Cable	146-62-074	146-62-074	146-62-074	146-62-074	146-62-075	146-62-075	146-62-076	146-62-076
‡	Rollout Shield	425-00-932	425-00-933	425-00-934	425-00-935	425-00-936	425-00-937	425-00-938	425-00-939

ALTERNATE PARTS FOR CONTINUOUS PILOT - 24 VOLT

1	24 Volt Gas Valve, Continuous Pilot	---	146-62-061	146-62-061	146-62-061	146-62-061	146-62-061	146-62-061	146-62-061
7	Pilot Burner	---	146-62-055	146-62-055	146-62-055	146-62-055	146-62-055	146-62-055	146-62-055
8	Thermocouple	---	146-62-037	146-62-039	146-62-039	146-62-039	146-62-039	146-62-036	146-62-036

Quantity is 1 unless otherwise noted.

* Requires 1 less than the number of sections.

** Requires 2 less than the number of sections.

‡ Not Illustrated.

Repair Parts

BOILER CONTROLS AND PIPING

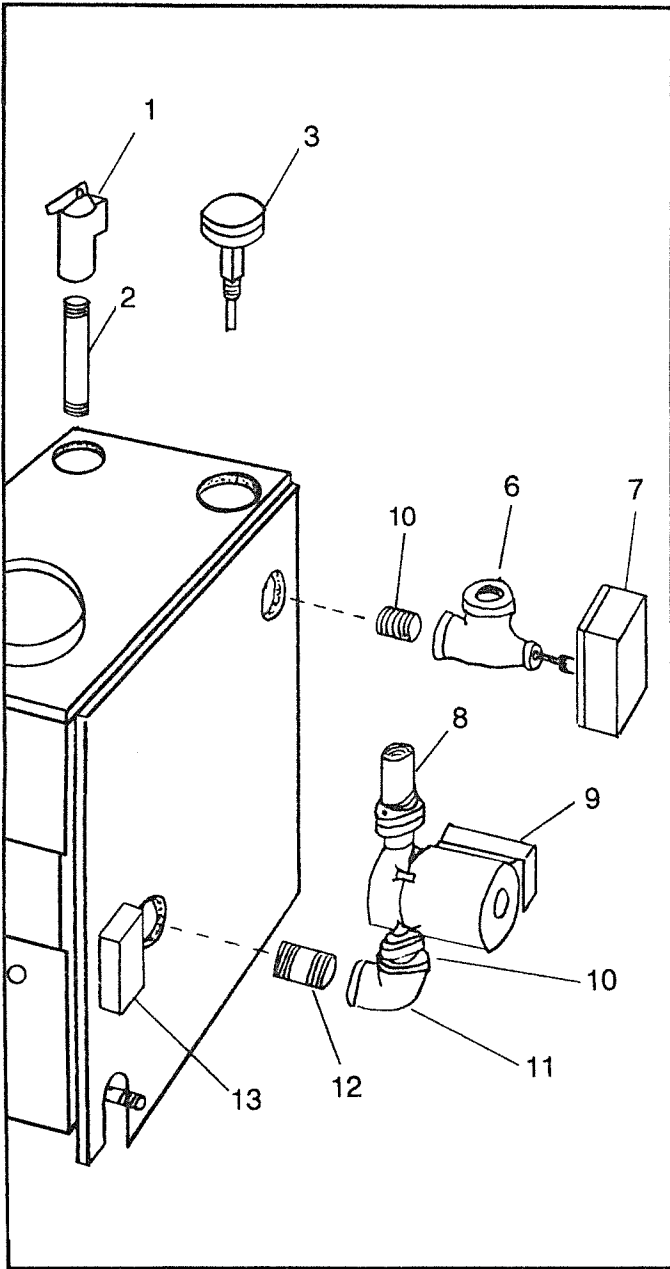

KEY NO.	DESCRIPTION	PART NO.
1	3/4" ASME Relief Valve	146-22-011
2	3/4" x 7 1/2" Nipple	146-07-041
3	Temperature Pressure Gauge - 5" Stem	146-23-009
6	1 1/4" x 3/4" x 1 1/4" Tee	146-93-049
7	Aquastat Relay	433-00-523
†	Isolation Valve Set - Grundfos	146-26-046
8	Isolation Valve Set - Taco	146-26-048
†	Cast Iron Flange Set - Grundfos	146-26-050
†	Cast Iron Flange Set - Taco	146-26-049
†	Grundfos UP15-42F Circulator	146-26-045
9	Taco 007 Circulator	146-26-047
10	1 1/4" x 2 1/2" Nipple	146-07-044
11	1 1/4" Ell	146-93-042
12	1 1/4" x 3 1/2" Nipple	146-07-008
13	Intermittent Pilot Control - Natural Gas	146-62-303
	- Propane Gas	146-62-071
†	Spill Switch (36TX16-6281) 340° F	146-60-001
†	Rollout Switch	146-29-002
†	4" Vent Damper (with 3" Adapter)	146-28-011
†	5" Vent Damper	146-28-001
†	6" Vent Damper	146-28-002
†	7" Vent Damper	146-28-003
†	Vent Damper Operator (Motor)	146-28-006

† Not Illustrated

