



D E S I G N E D T O L E A D

# Mega-Stor™

Stainless Steel, Indirect Water Heaters

- INSTALLATION AND OPERATING INSTRUCTIONS
  - ENGINEERING MANUAL
    - MAINTENANCE
      - PARTS

## CAUTION

1. The heat transfer-medium must be water or other nontoxic fluid having a toxicity rating or Class of 1, as listed in Clinical Toxicology of Commercial Products, 5th edition.
2. The pressure of the heat transfer medium must be limited to a maximum of 30 PSIG by an approved safety or relief valve.



---

Manufacturer of Hydronic Heating Products  
P.O. Box 14818 3633 I. Street  
Philadelphia, PA 19134  
[www.crownboiler.com](http://www.crownboiler.com)

# CONTENTS

I.	Product Description . . . . .	2
II.	Specifications . . . . .	2
III.	Sizing . . . . .	4
IV.	Zone Design . . . . .	6
V.	Before Starting Installation . . . . .	11
VI.	Locating The Mega-Stor . . . . .	11
VII.	Piping . . . . .	12
	Boiler Side Piping . . . . .	12
	Domestic Piping . . . . .	15
VIII.	Wiring . . . . .	21
IX.	Start-up and Check-out . . . . .	24
X.	Maintenance . . . . .	25
XI.	Parts . . . . .	26

# I. PRODUCT DESCRIPTION

The Crown Mega-Stor series indirect water heater is designed to generate domestic hot water in conjunction with a hot water boiler using forced boiler water circulation. This indirect water heater consists of a stainless steel tank in which a smooth stainless steel coil is located. Boiler water is pumped through the coil and heats the water in the tank. This tank is not intended for use in pool heating applications or for heating any other fluid other than water. It is also not intended for use in gravity hot water heating systems.

## IMPORTANT NOTE

Some localities require indirect water heaters having a relief valve capacity in excess of 200,000 BTU/hr to be constructed and stamped in accordance with ASME requirements. Check with the local authority having jurisdiction before installing an MS-79 or MS-119 with a boiler or boilers having a total gross output in excess of 200,000 BTU/hr.

# II. SPECIFICATIONS

**TABLE 2.1: AHRI PERFORMANCE SPECIFICATIONS**

Model	First Hour Rating	Continuous Draw Rating	Standby Loss (°F/hr)	Minimum Boiler Output (MBH)	Boiler Water Through Coil	
	(Gal/hr)	(Gal/hr)			Min Flow (Gal/min)	Head Loss (ft w.c.)
MS-26	144	121	1.7	77	8.0	2.5
MS-40	195	157	1.4	102	8.0	3.0
MS-53	226	179	0.9	114	8.0	3.5
MS-79	287	218	1.0	145	8.0	4.8
MS-119	472	384	1.4	225	12.7	7.9
MSH-40	151	116	1.4	75	8.0	2.5
MSH-53	203	158	1.3	101	8.0	3.5

Notes:

AHRI ratings based on 77F DHW temperature rise (135F outlet temp) and 180F boiler supply temperature. The ratings in Table 2.1 were obtained at the heat source (boiler) output rates and heat source flow rates shown above. Other results shall be obtained under different conditions.

Pressure Ratings:

Maximum Allowable Tank Working Pressure - 150 psi  
 Design Hydrostatically Tested to 300 psi



**FIGURE 2.2: MEGA-STOR INDIRECT WATER HEATER**

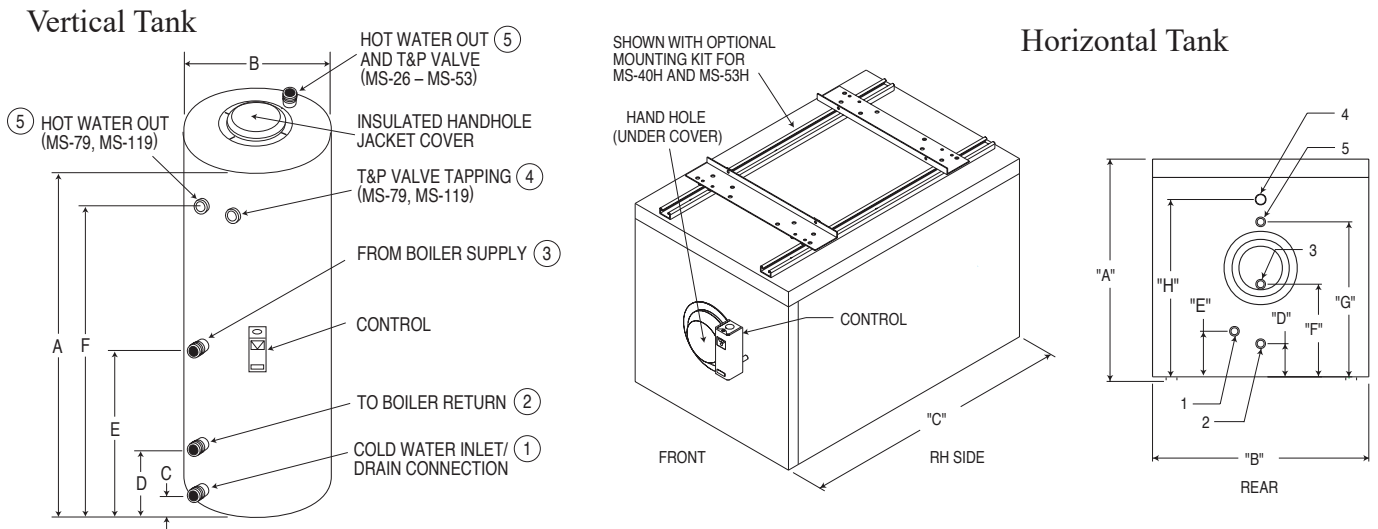

**TABLE 2.3: PHYSICAL SPECIFICATIONS**

Model	Potable Volume (Gal.)	Dimensions in Inches								Coil Surface (Sq. Ft.)	Weight	
		A	B	C	D	E	F	G	H		Net	Full
MS-26	25.6	38-3/4	20-1/4	2	9-3/4	22-1/2	---	---	---	6.5	57	269
MS-40	38.7	54-3/4	20-1/4	2	9-3/4	25-3/4	---	---	---	8.6	77	396
MS-53	51.1	47-7/8	23-7/8	2	9-7/8	26-3/4	---	---	---	10.1	103	522
MS-79	80.0	69-1/4	23-3/4	1-5/8	10-1/4	29-1/4	59-1/4	---	---	15.1	204	831
MS-119	111.7	66	29-1/2	2-1/2	12-3/4	36-1/4	52-3/4	---	---	24.3	218	1178
MSH-40*	37.6	24-3/8	23-7/8	34-11/16	3-5/8	5	10-1/8	16-7/8	19-3/8	6.7	127	449
MSH-53*	51.0	24-3/8	23-7/8	44-7/8	3-5/8	5	10-1/8	16-7/8	19-3/8	9.8	168	595

\*Horizontal Tank

**TABLE 2.4: CONNECTIONS**

Key #	Description	Size (NPT)			
		MS-26 MS-53	MSH-40 MSH-53	MS-79	MS-119
1	Cold Water Inlet	3/4M	3/4M	1M	1-1/4M
2	To Boiler Return	3/4M	3/4M	3/4M	1-1/4M
3	From Boiler Supply	3/4M	3/4M	3/4M	1-1/4M
4	T&P Valve Tapping	---	3/4F	1F	1F
5	Hot Water Out	3/4M	3/4M	1F	1-1/4F

# III. SIZING

## IMPORTANT

The following procedures are used to size indirect water heaters based on the amount of hot water which will be required during a given hour. In doing so it is assumed that this demand will be evenly spread out over the course of the entire hour.

THESE SIZING PROCEDURES ARE PROVIDED AS A GUIDE TO ASSIST THE PROFESSIONAL CONTRACTOR IN SIZING MEGA-STOR TANKS. BECAUSE OF THE LARGE VARIETY OF DEMAND SITUATIONS ENCOUNTERED IN THE FIELD, CROWN BOILER COMPANY CANNOT GUARANTEE THE SUITABILITY OF THESE PROCEDURES TO ALL INSTALLATIONS.

### Residential Applications

Table 3.1 shows the minimum sized Mega-Stor that should be considered for one and two family homes based on the numbers of bedrooms and bathrooms being served. In cases where the boiler is sized significantly larger than that shown in column (d) in order to meet space heating demand, there is usually no need to add boiler capacity just for the Mega-Stor. Note that the sizing recommendations shown in Table 3.1 may not provide satisfactory performance when there are unusually high peak demands, such as when multiple showers are used simultaneously or when a Whirlpool tub is filled. To address these cases, review Tables 3.2 and 3.3 and make adjustments to Mega-Stor and/or boiler size, to make sure that the peak demand can be satisfied. For Whirlpool tubs, it is recommended that the Mega-Stor have a domestic water volume at least as large as the nominal volume of the tub.

### Commercial Applications

Use a fixture count method to determine the domestic hot water demand, such as that shown in the Service Water Heating chapter of the *ASHRAE Applications Handbook*. Then use the data provided in Tables 2.1, 3.2, and 3.3 to select the boiler and Mega-Stor.

**Table 3.1: Mega-Stor Sizing for Typical One and Two Family Units**

(a)	(b)	(c)	(d)	(e)
Number of Bathrooms	Number of Bedrooms	Mega-Stor	First Hour Requirement (GPH)	Min. Boiler Output (MBH)
1 to 1 1/2	1	MS-26	43	27
	2	MS-40	60	36
	3	MS-40	60	36
2 to 2 1/2	2	MS-40	60	36
	3	MS-40	70	36
	4	MS-40	72	38
	5	MS-53	90	47
3 to 3 1/2	3	MS-53	72	47
	4	MS-53	82	47
	5	MS-53	90	47
	6	MS-53	92	47

**Table 3.2: Maximum Possible Continuous Draw  
(180F Boiler Supply, 77F DHW Rise, 135F Outlet)**

(a)	(b)	(c)
Mega-Stor	Continuous Draw (Gal/min)	Min Boiler Output (MBH)
MS-26	2.0	77
MS-40	2.6	102
MS-53	3.0	114
MS-79	3.6	145
MS-119	6.4	225
MSH-40	1.9	75
MSH-53	2.6	101

**Table 3.3: AHRI First Draw Rating\***

(a)	(b)	(c)
Mega-Stor	Draw Rate (GPM)	First Draw Rating (Gal)
MS-26	2.0	22.6
MS-40	2.6	38.2
MS-53	3.0	46.5
MS-79	3.6	69.3
MS-119	6.4	88.3
MSH-40	1.9	35.6
MSH-53	2.6	44.6

\* First Draw Rating is the amount of stored water available from a fully recovered Mega-Stor, with no boiler output during the draw, before the outlet temperature falls by 25F. At draw rates higher than that shown in column (b), less stored hot water may be available.

# IV. ZONE DESIGN

## IMPORTANT

**All First Hour Ratings shown in this manual are based on the boiler water flow rates shown in Table 2.1. Read this section for information on sizing, piping and circulators for the Mega-Stor zone.**

In designing the Mega-Stor zone piping system the following points should be considered:

- 1) Circulator or Zone Valve Zoning? - Circulator zones are usually a better choice. Zone valves have a relatively high pressure drop at the flow rate required through the Mega-Stor coil (see Table 2.1). If zone valves are selected, use a zone valve with a minimal delay in opening, such as a motorized type.
- 2) Priority Zoning - Priority zoning is used to divert all boiler output to the Mega-Stor when its zone calls for heat regardless of any simultaneous calls for heat from space heating zones. Priority zoning can be done using a 3-way zone valve, or by using a relay to de-energize the heating zones when the Mega-Stor calls for heat. See the Piping and Wiring Sections for more information on these zone systems.
- 3) Use Worksheet 1 to size piping and select a circulator for the Mega-Stor zone. To do this:
  - a) Use column (a) to enter the total number of each type of fitting. For straight pipe enter the total number of feet. When counting fittings, count all fittings in the Mega-stor zone as well as all fittings in the piping common to all zones (zone manifolds, etc.).
  - b) Refer to Table 1 to find the required flow rate through the Mega-Stor coil.
  - c) Columns (b) and (c) each show pressure drops for fittings at a given flow rate. Select the appropriate column for the required flow rate. Multiply the number of each type of fitting by the pressure drop in the column selected. Enter the result in column (d).
  - d) Total column (d). This is the total pressure drop for the Mega-Stor zone.
  - e) Use Table 4.1 or a circulator manufacturer's literature to select a circulator which will develop the required flow rate at the pressure drop calculated.

**TABLE 4.1: SELECTING A CIRCULATOR**

Circulator	AVAILABLE HEAD (FT. W.C.)	
	8.0 GPM	12.7 GPM
Taco 007	8.2	5.8
Taco 008	9.8	4.2
Taco 0014	17.5	15.2
Grundfos UPS 15-42F	9.0	5.0
Grundfos UP 26-64F	21.0	16.0

Select a circulator which has an Available Head greater than the pressure drop calculated using Worksheet 3.

## WORKSHEET 1: PRESSURE DROP CALCULATIONS THROUGH MEGA-STOR ZONE

Fitting Description	Quantity (a)	HEAD LOSS (FT W.C.)		Total (d)
		8.0 GPM (b)	12.7 GPM (c)	
MS-26, MSH-40 Coil		2.5	---	_____
MS-40 Coil		3.0	---	_____
MS-53, MSH-53 Coil		3.5	---	_____
MS-79 Coil		4.8	---	_____
MS-119 Coil		---	7.9	_____
1 ft 1" St. Pipe	_____ft	0.05	0.13	_____
1 ft 1-1/4" St. Pipe	_____ft	0.01	0.03	_____
1 ft 1-1/2" St. Pipe	_____ft	0.01	0.01	_____
1" 90 El	_____	0.16	0.40	_____
1-1/4" El	_____	0.06	0.15	_____
1-1/2" El	_____	0.04	0.10	_____
1" Run of Tee	_____	0.05	0.13	_____
1-1/4" Run of Tee	_____	0.02	0.05	_____
1-1/2" Run of Tee	_____	0.01	0.03	_____
1" Branch of Tee	_____	0.26	0.66	_____
1-1/4" Branch of Tee	_____	0.08	0.20	_____
1-1/2" Branch of Tee	_____	0.05	0.13	_____
1" Std. Ball Valve	_____	0.12	0.30	_____
1-1/4" Std. Ball Valve	_____	0.06	0.15	_____
1-1/2" Std. Ball Valve	_____	0.02	0.05	_____
Taco #220 (1")	_____	2.18	5.49	_____
"Flo-Chek" #221 (1-1/4")	_____	0.84	2.12	_____
#222 (1-1/2")	_____	0.44	1.11	_____
Taco Air #431 (1")	_____	0.15	0.38	_____
Scoop #432 (1-1/4")	_____	0.05	0.25	_____
Honeywell Zone Valves				
V8043F1101 (1" Cv=8)		2.31	4.69	_____
Allowance for bushings and sudden transitions*	1	0.53	1.34	_____
Boiler**	_____			_____
Total Head Loss Through Manifold Piping and Mega-Stor Zone				_____

\*Includes (2) 1-1/2 x 3/4 and (2) 1-1/2 x 1 transitions

\*\*Pressure drop through boiler can be ignored for most cast iron or steel boilers. If in doubt, consult the boiler manufacturer.

Above pressure drops may be used for black pipe or copper tubing.



## EXAMPLE 1

Size a circulator for the Mega-Stor zone shown below. An MS-40 is to be used with an 8 GPM flow rate through the coil.

- 1) Using Worksheet 1, record the total number of fittings in Mega-Stor zone and piping common to all zones (piping shown in bold) in column (a).
- 2) Since 8 GPM is required, use the pressure drops shown in column (b). Multiply each entry in column (a) by the corresponding pressure drop in column (b). Enter the result in column (d).
- 3) The total of column (d) is 7.94 ft. of head. This is the total pressure drop for the Mega-Stor zone.
- 4) Select a pump which will develop 7.94 ft of Head at 8 GPM. From Table 4.1, we see that either a Taco 007 or a Grundfos UPS 15-42F can be used.

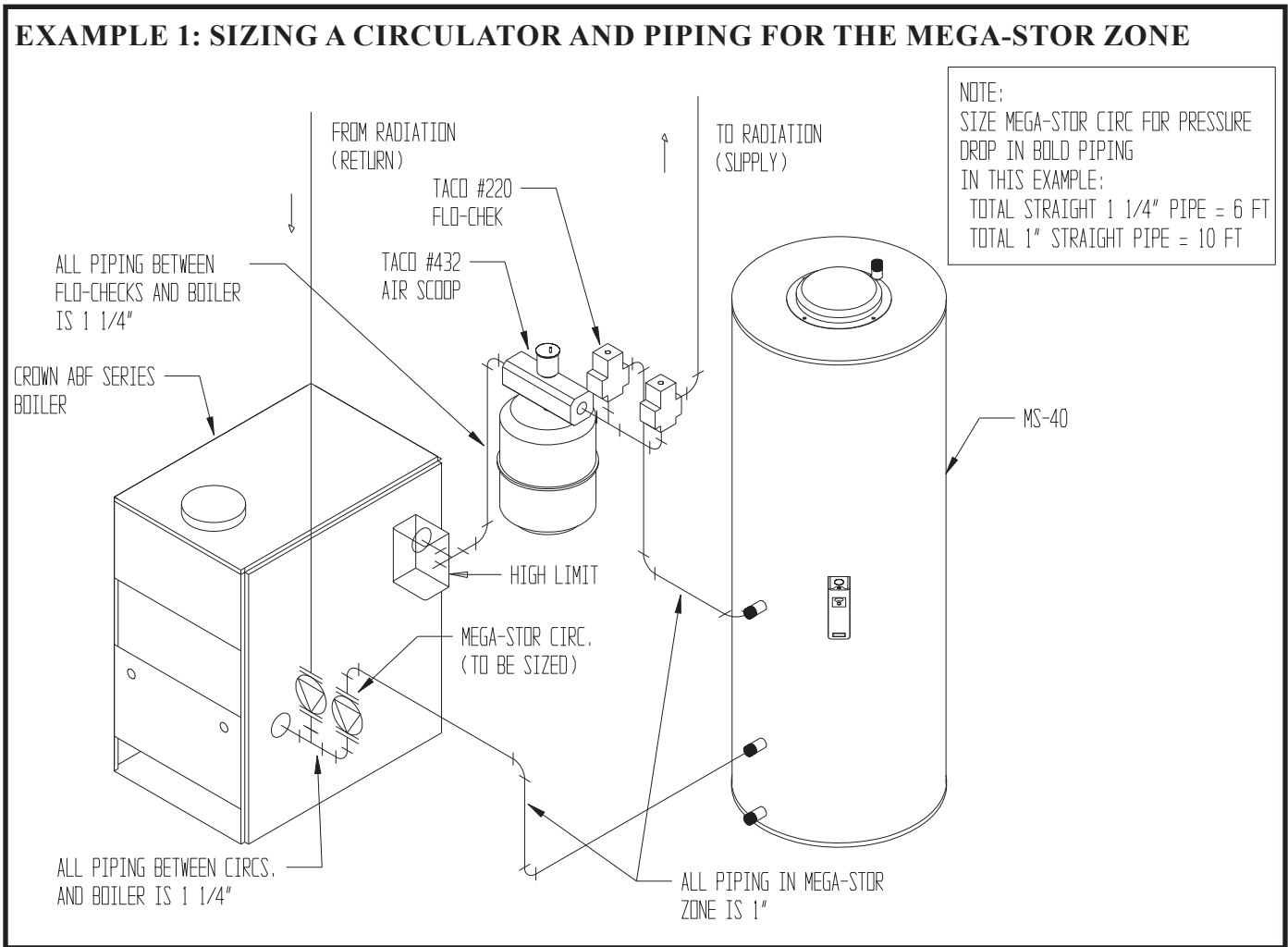

**FIGURE 4.2: COMPLETED WORKSHEET 3  
PRESSURE DROP CALCULATIONS THROUGH MEGA-STOR ZONE**

Fitting Description	Quantity (a)	HEAD LOSS (FT W.C.) Flow		Total (d)
		8.0 GPM (b)	12.7 GPM (c)	
MS-26 Coil, MSH-40 Coil		2.5	---	---
MS-40 Coil		3.0	---	<u>3.0</u>
MS-53, MSH-53H Coil		3.5	---	---
MS-79 Coil		4.8	---	---
MS-119 Coil		---	7.9	---
1 ft 1" St. Pipe	<u>10</u> ft	0.05	0.13	<u>0.50</u>
1 ft 1-1/4" St. Pipe	<u>6</u> ft	0.06	0.03	<u>0.36</u>
1 ft 1-1/2" St. Pipe	_____ft	0.01	0.01	_____
1" 90 El	<u>6</u>	0.16	0.40	<u>0.96</u>
1-1/4" El	<u>3</u>	0.06	0.15	<u>0.18</u>
1-1/2" El	_____	0.04	0.10	_____
1" Run of Tee	_____	0.05	0.13	_____
1-1/4" Run of Tee	<u>1</u>	0.02	0.05	<u>0.02</u>
1-1/2" Run of Tee	_____	0.01	0.03	_____
1" Branch of Tee	_____	0.26	0.66	_____
1-1/4" Branch of Tee	<u>2</u>	0.08	0.20	<u>0.16</u>
1-1/2" Branch of Tee	_____	0.05	0.13	_____
1" Std. Ball Valve	_____	0.12	0.30	_____
1-1/4" Std. Ball Valve	_____	0.06	0.15	_____
1-1/2" Std. Ball Valve	_____	0.02	0.05	_____
Taco #220 (1")	<u>1</u>	2.18	5.49	<u>2.18</u>
"Flo-Chek" #221 (1-1/4")	_____	0.84	2.12	_____
#222 (1-1/2")	_____	0.44	1.11	_____
Taco Air #431 (1")	_____	0.15	0.38	_____
Scoop #432 (1-1/4")	<u>1</u>	0.05	0.25	<u>0.05</u>
Honeywell Zone Valves V8043F1101 (1" Cv=8)		2.31	4.69	_____
Allowance for bushings and sudden transitions*	<u>1</u>	0.53	1.34	<u>0.53</u>
Boiler**	_____			<u>0</u>
<b>Total Head Loss Through Manifold Piping and Mega-Stor Zoning</b>				<u><b>7.94</b></u>

\*Includes (2) 1-1/2 x 3/4 and (2) 1-1/2 x 1 transitions

\*\*Pressure drop through boiler can be ignored for most cast iron or steel boilers. If in doubt, consult the boiler manufacturer.

Above pressure drops may be used for black pipe or copper tubing.

## V. BEFORE STARTING INSTALLATION

- 1) Be sure that the planned installation is in accordance with all local codes.
- 2) Be certain the domestic water supply to the tank has physical and chemical characteristics that fall within the limits shown in Table 5.1. Where questions exist as to the composition of the water on the job, a qualified water treatment expert should be consulted.
- 3) Read and understand all installation requirements in this manual.

### IMPORTANT

Water with characteristics outside the limits shown in Table 5.1 may severely shorten the life of the tank due to corrosion. Damage to tanks in such cases is not covered under warranty.

### TABLE 5.1: WATER CHEMISTRY REQUIREMENTS

Water used in the Mega-Stor must have characteristics falling within the following limits:

Characteristic	Min	Max
pH	6.0	8.0
Chloride (PPM)	0.0	80.0

## VI. LOCATING THE MEGA-STOR

- 1) Table 2.3 shows the weights of all Mega-Stors filled with water. Make sure that the location chosen for the Mega-Stor is capable of supporting it.

### WARNING

Failure to properly support an MS tank could result in property damage or personal injury.

- 2) Locate the Mega-Stor in a location where a leak in the tank, the adjacent piping, or an open T&P valve will not damage the surrounding structure. If the area around the desired tank location is highly susceptible to water damage, install the Mega-Stor in a pan with a drain.
- 3) The Mega-Stor may be located some distance from the boiler provided the zone system is designed to provide the flow called for in Table 2.1 through the coil. Also, the further the Mega-Stor is from the boiler, the longer the response of the boiler will be to a call from the Mega-Stor zone. If long runs exist between the boiler and Mega-Stor it is advisable to insulate the piping.

# VII. PIPING

## 1) BOILER SIDE PIPING

Figures 7.1 thru 7.4 show typical boiler side piping for several common situations. Regardless of which system is used it is imperative that the flow rates called for in Table 1 are developed through the coil. This requires properly sized piping and a properly sized pump. To determine the pipe/pump sizes required see page 6.

The systems shown in Figures 7.1 thru 7.4 are described below:

### STANDARD CIRCULATOR ZONE

This system is just like the circ zone system on a straight heat job except that one of the zones goes to the MS tank instead of radiation. As on any circulator zone system, check valves should be installed in each zone to prevent unwanted circulation through zones which are not calling for heat. Figure 7.1 illustrates typical circ zone piping.

### ZONE VALVE SYSTEM

Figure 7.2 illustrates a typical Mega-Stor installation using zone valves. The circulator must be large enough to move boiler water through the coil at the flow rate in Table 2.1, regardless of the flow rate required through the heating zones.

### 3-WAY ZONE VALVE SYSTEM

Figure 7.3 illustrates typical piping using a 3-way zone valve. In this system a 3-way zone valve is used which has a common port, a “normally open” port, and a “normally closed” port. The zone valve motor is wired so as to be energized by the Mega-Stor thermostat (see Part VIII for wiring information). The common side of the zone valve is connected to the boiler. The heating zone is connected to the normally open side of the zone valve and the Mega-Stor coil is connected to the normally closed side of the zone valve. As long as the Mega-Stor is not calling for heat, boiler water can flow from the space heating zone, through the normally open side of the 3-way valve, to the boiler. As soon as the Mega-Stor calls for heat, the zone valve is energized, and boiler water can only flow through the Mega-Stor zone.

### MEGA-STOR MANIFOLD PIPING (BOILER SIDE)

Multiple tank installations must be done in the “reverse return” manner illustrated in Figure 7.4. The reason for this is to create the same pressure drop (and therefore the same flow) through the coil of each tank. The boiler manifold piping must be sized so that each coil has the flow rate called for in Table 2.1. For example, if two MS-26's are to be manifolded together, the circulator and zone piping common to both tanks must be capable of moving 16 GPM (2 x 8GPM).

Because the pressure drop through Mega-Stor coils varies from size to size, it is hard to predict the flow rate that will be developed through each coil when two Mega-Stors of different sizes are placed in the same manifold. For this reason it is best not to mix Mega-Stors of two different sizes in the same zone if their recovery is critical.

**FIGURE 7.1: BOILER-SIDE PIPING USING CIRCULATOR ZONES**

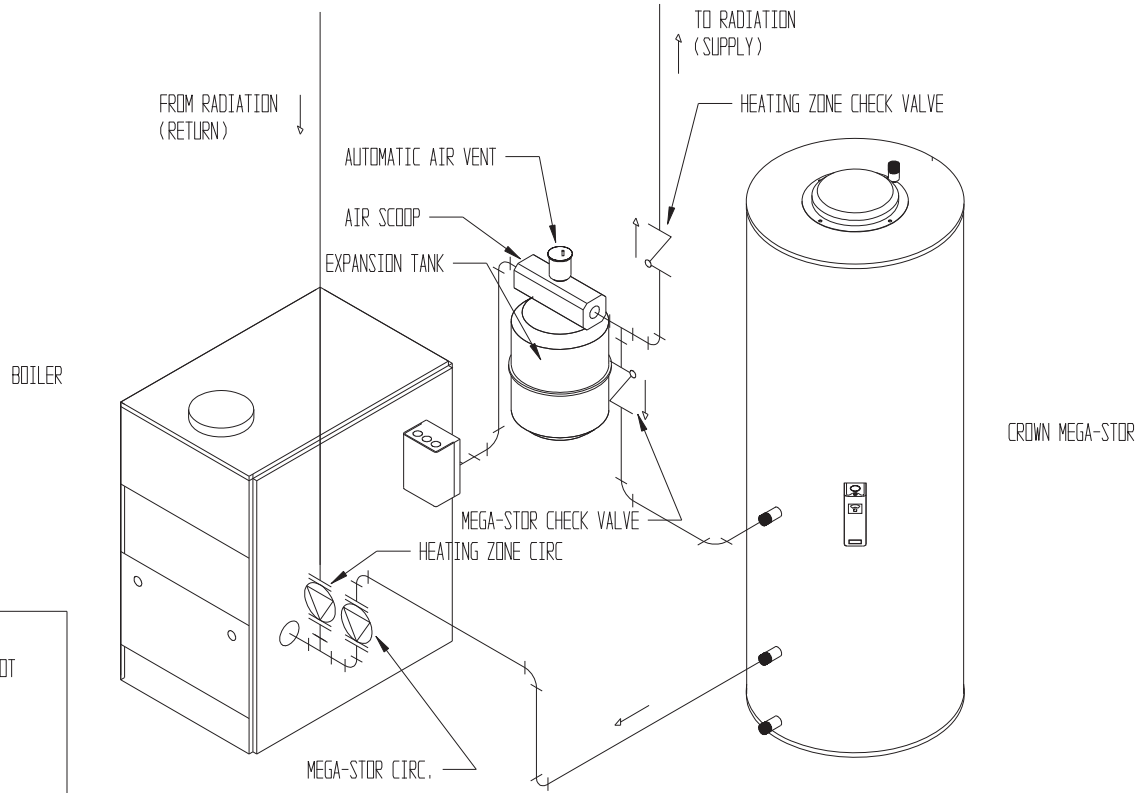

**FIGURE 7.2: BOILER-SIDE PIPING USING ZONE VALVES (2-WAY)**

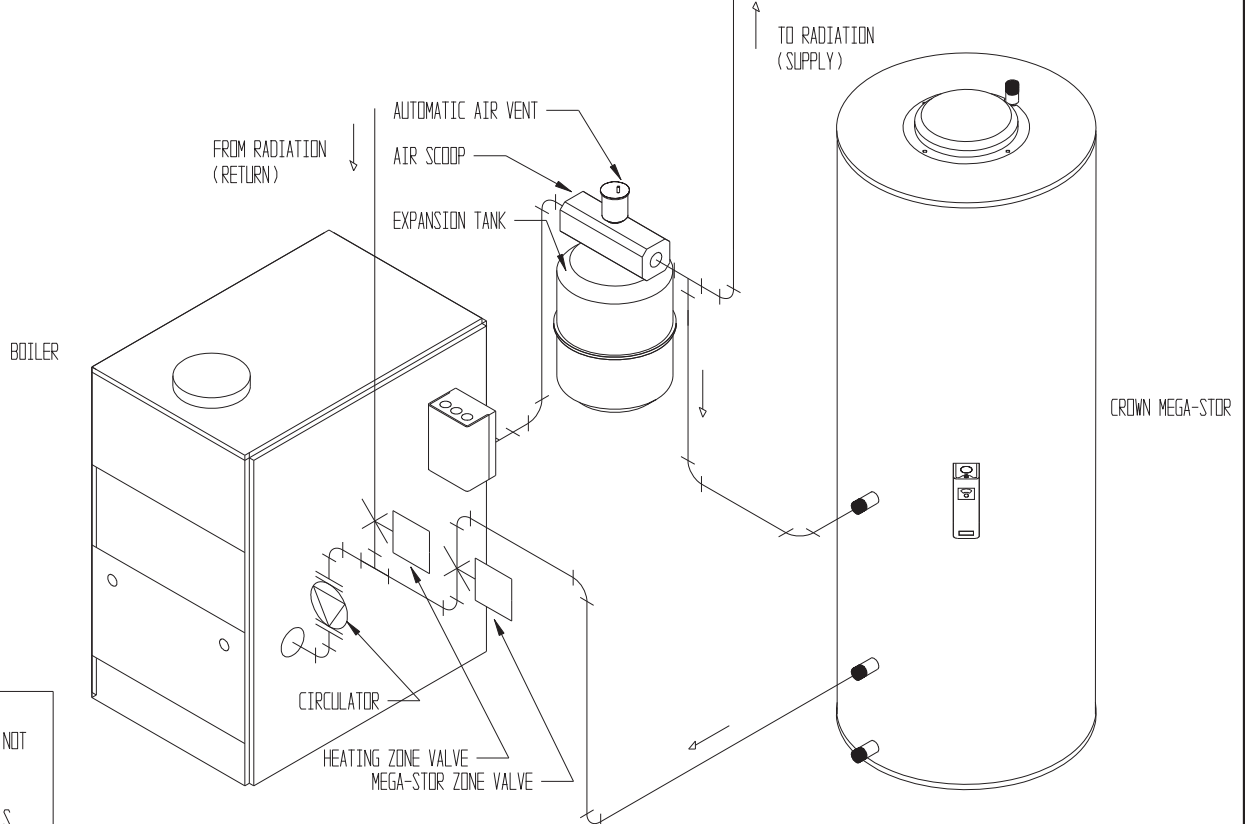

**FIGURE 7.3: BOILER-SIDE PIPING USING A THREE WAY ZONE VALVE**

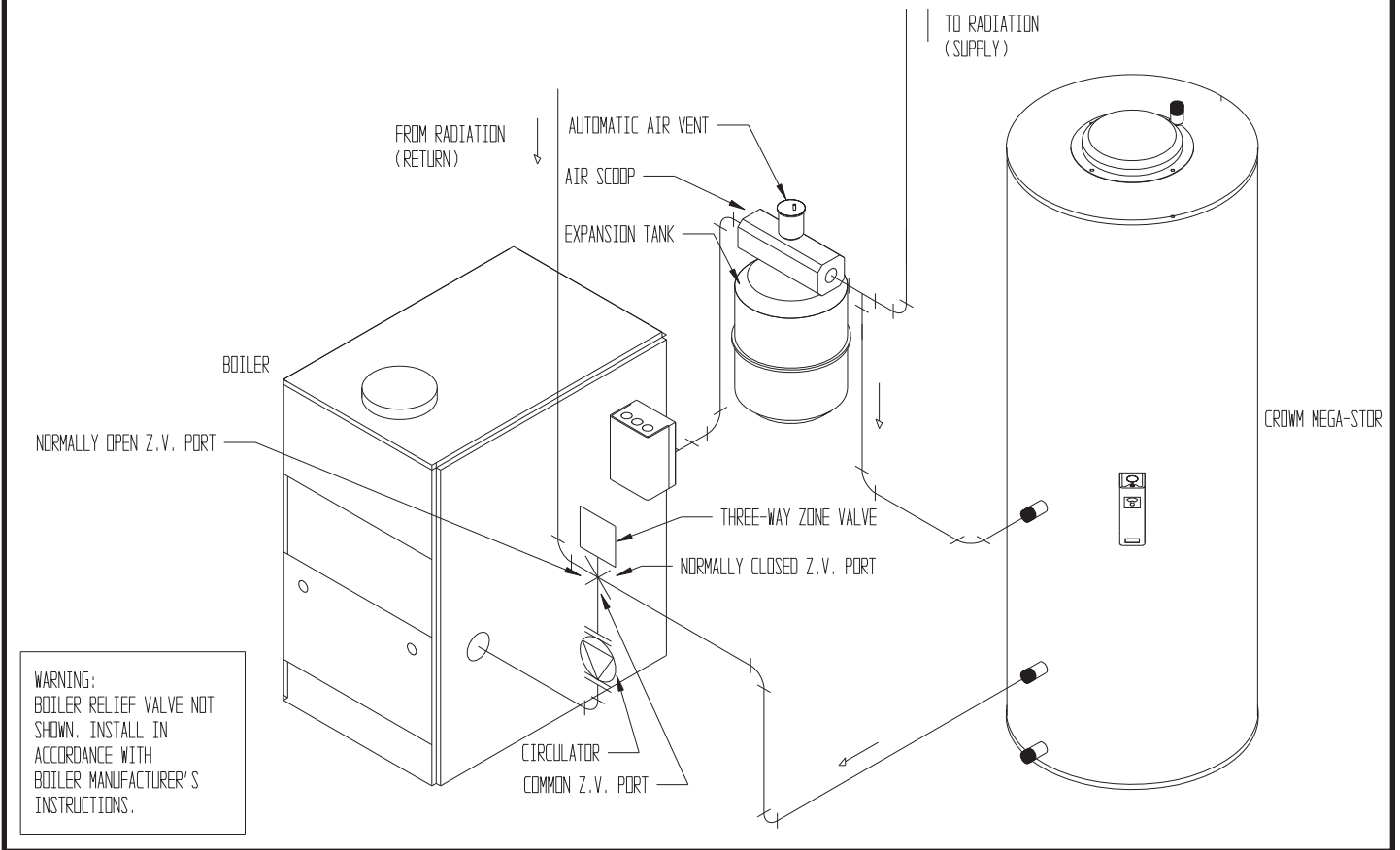

**FIGURE 7.4: BOILER-SIDE PIPING FOR MULTIPLE MEGA-STORS**

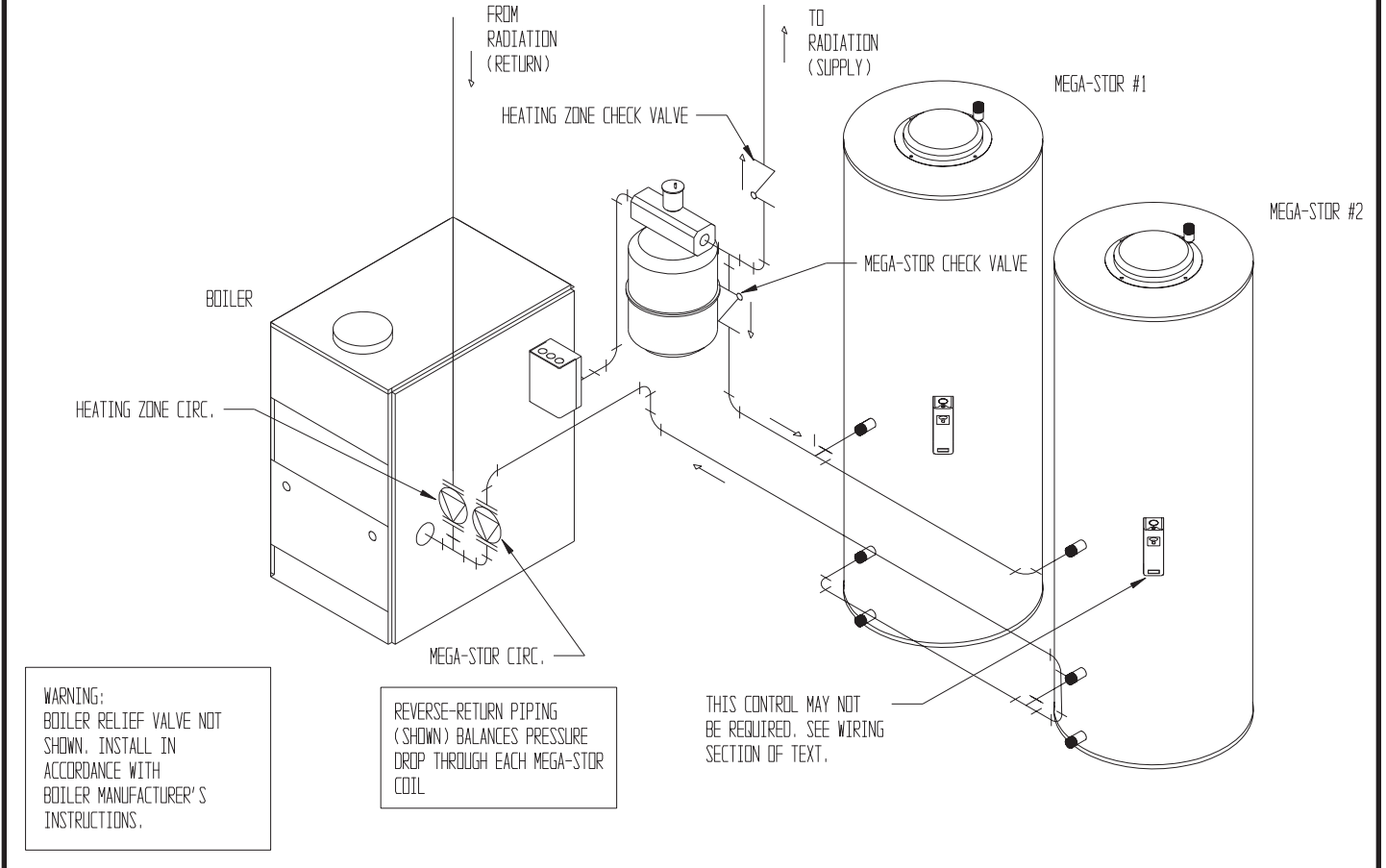

## 2) DOMESTIC SIDE PIPING

### BASIC DOMESTIC PIPING

Figure 7.6A shows typical domestic water piping for a Mega-Stor. All components except the control are provided by the installer. The function of the components shown are as follows:

- a) Temperature Control (required) - This control is provided by Crown and must be installed in the aquastat well location of the water heater indicated in Figure 2.2. Remove the cover and loosen the clamping screws. Insert the capillary bulb so that it is “bottomed out” in the control well as shown in Figure 7.5 and screw the control clamp securely in the well groove at the end of the well. See Section VIII for wiring details and Section IX for instructions on adjusting the temperature setting.
- b) Shut-off valves (recommended) - Use to isolate the tank for servicing.
- c) Backflow Preventer (required by some codes) - Use to prevent water from backing out of the Mega-Stor in the event that inlet water pressure drops.
- d) Expansion Tank (required when a backflow preventer is used) - This expansion tank absorbs the increased volume caused by heating water. If a backflow preventer is installed, this expansion tank is required because the increased water volume will otherwise have no place to go and the T&P valve will open. Use an expansion tank designed for use on domestic water systems such as Watts DET series expansion tank. Refer to the expansion tank manufacturer’s literature for the proper size expansion tank to use.

### IMPORTANT

If an expansion tank is used, do not put any valves between the expansion tank and Mega-Stor inlet.

- e) Unions (optional) - Use to disconnect the Mega-Stor in the event that this is necessary.
- f) Drain (Required) - Used to drain the tank for inspection or servicing.
- g) Temperature/Pressure Relief Valve (required) - Opens to relieve excess pressure or temperature which has developed in the Mega-Stor. This valve must comply with ANSI Z21.22 Standard for Relief Valves and Automatic gas Shutoff Devices for Hot Water Supply Systems and must be sized in accordance with Table 7.7.

Pipe this valve as shown in Figure 7.6B or 7.6C. Run the discharge to a location where hot water discharge will not cause injury or damage. Leave a 6” gap between the T&P valve pipe termination and the drain or closest obstruction. Do not run T&P valve discharge pipe to the outdoors or other potentially freezing location. Make sure the discharge line is installed to allow complete drainage of both the valve and line.

### IMPORTANT

Do not put any valves between the relief valve and the tank.  
Do not install a reducing coupling or otherwise restrict the discharge line.

- h) Vacuum Breaker (Recommended) - This valve protects the tank in the event that the pressure in the tank falls below atmospheric. Use a Watts N-36 or equivalent.
- i) Heat Trap (Optional) - The heat trap retards the migration of heat from the Mega-Stor up the hot water supply pipe.

**FIGURE 7.5: AQUASTAT INSTALLATION**

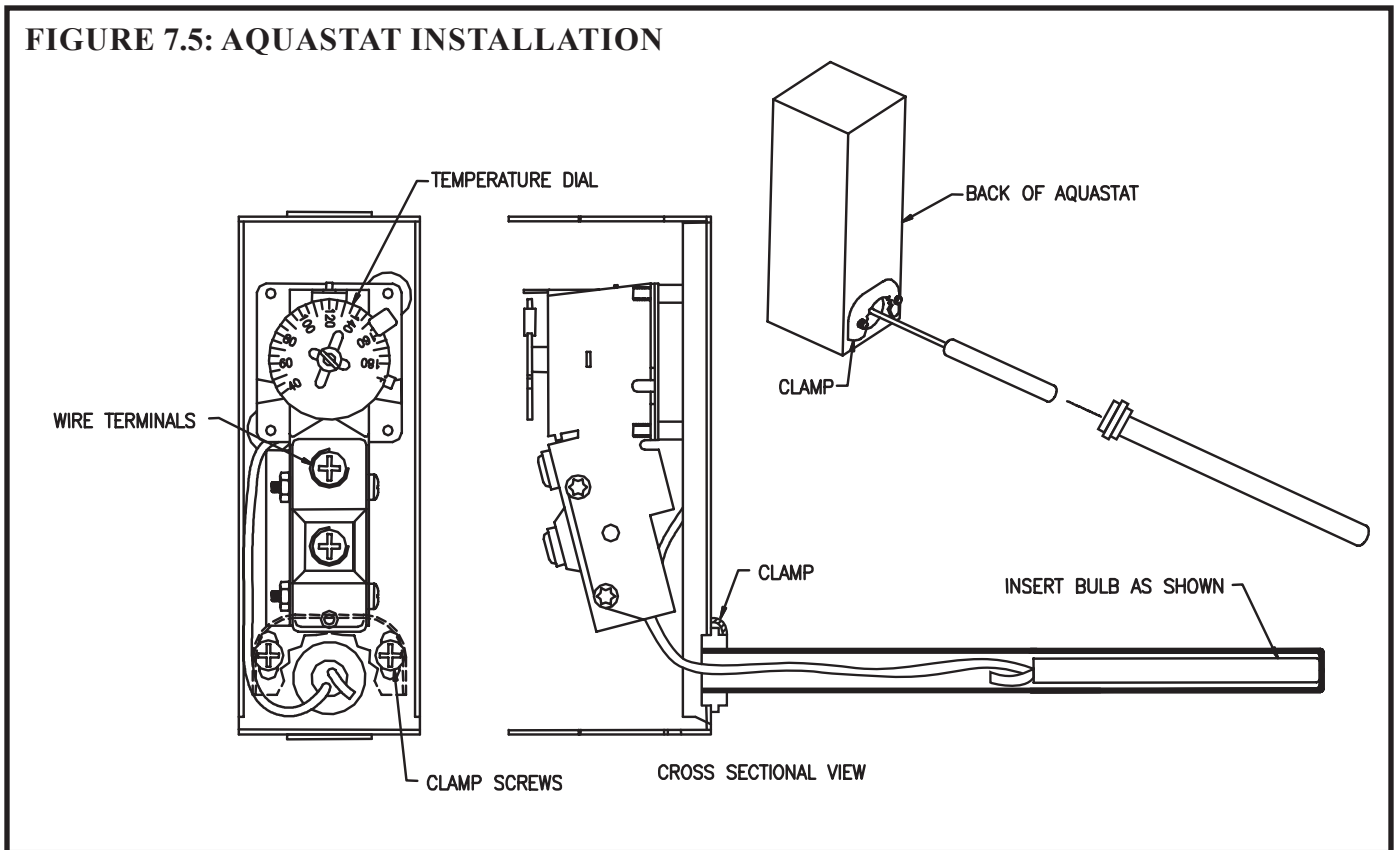

### **MEGA-STOR PIPING WITH A “TEMPERATURE LIMITING VALVE”**

Usually, the maximum temperature of the outlet water will stay near the setting of the Mega-Stor control. In some cases, however, hot water usage patterns can cause the outlet water temperature to rise significantly above the control setting.

The temperature of water going to the fixtures may be more carefully controlled through the use of a thermostatic mixing valve. This device blends a controlled amount of cold water with the hot water leaving the Mega-Stor so that water at a more constant temperature exits the mixing valve. Typical thermostatic mixing valve piping is illustrated in Figure 7.8. Consult a licensed plumber or the local plumbing authority for requirements in your area.

### **WARNING**

**A thermostatic mixing valve does not eliminate the risk of scalding.**

- \* Set the Mega-Stor thermostat as low as practical.
- \* Feel water before bathing or showering
- \* If anti-scald or anti-chill protection is required, use devices specifically designed for such service. Install these devices in accordance with their manufacturer’s instructions.

### **DOMESTIC WATER PIPING FOR DISTANT FIXTURES**

In some cases the furthest fixture may be quite distant from the Mega-Stor. In such an installation the configuration shown in Figure 7.6A or 7.8 would result in an unacceptable delay before hot water reaches these distant fixtures. Even if all the fixtures are relatively close to the Mega-Stor, the building owner may want hot water at all fixtures as soon as they are opened.

Figure 7.9 illustrates a solution to this problem. In it, a pipe is run from the furthest fixture on each branch back to the return of the Mega-Stor. A small bronze circulator is mounted in this line and is wired so as to run continuously. A check valve in this line permits flow towards the Mega-Stor inlet only.



**FIGURE 7.6A: BASIC DOMESTIC WATER PIPING**

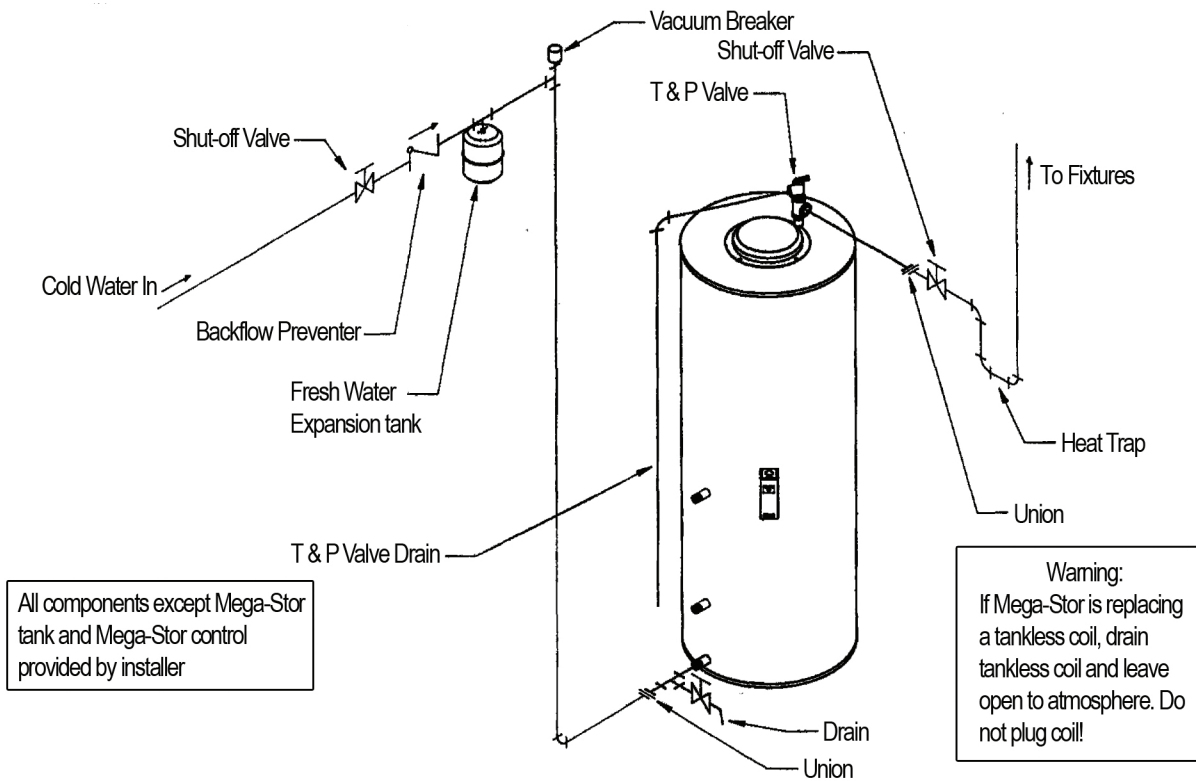

When no fixtures are drawing water, the bronze circulator moves hot water from the Mega-Stor to end of the branch just below the last fixture, then back to the inlet of the Mega-Stor via the return pipe. When a fixture is opened, hot water is already out in the branch very close to the fixture and hot water appears at it almost immediately. The check valve prevents cold water in the Mega-Stor's inlet pipe from passing around the tank and heading directly to the fixture.

Because hot water is always circulated in the hot water branch the entire branch should be insulated to prevent excessive heat loss.

**MANIFOLD DOMESTIC WATER PIPING**

Figure 7.10 illustrates the recommended method of piping the domestic water side of several tanks together. All Mega-Stors are piped in a "reverse-return" manner just like the boiler piping. This balances the pressure drop through each tank, resulting in an even flow rate through each tank.

Each tank must have its own T&P valve. It is recommended that each tank be equipped with its own isolation valves, unions, and drains so that one tank may be removed from the system. If local codes require a backflow preventer, check with the appropriate authority to find out whether one backflow preventer may be used for tanks or each tank must be equipped with its own backflow preventer. If each tank must have its own backflow preventer, each tank must also have its own expansion tank. If a common backflow preventer is permitted, an expansion tank must be sized to accommodate the expansion volume of all tanks.

**TABLE 7.7: MINIMUM T&P VALVE SIZES**

\*If the Mega-Stor is connected to a boiler which has a Gross Output LESS than the "Max. T&P Valve Capacity" shown below, install a T&P valve having a capacity greater than or equal to the boiler's Gross Output.

\*If the Mega-Stor is connected to a boiler which has a Gross Output GREATER than the "Max. T&P Valve Capacity" shown below, install a T&P valve having a capacity greater than or equal to the "Max T&P Valve Capacity."

<u>Model</u>	<u>Max T&amp;P Valve Capacity (BTU/hr)</u>
MS-26	172,800
MS-40	181,800
MS-53	199,800
MS-79	215,100
MS-119	445,635
MSH-40	103,344
MSH-53	145,289

\*Maximum T&P valve pressure setting - 150 psi

**FIGURE 7.6B: CORRECT TEMPERATURE & PRESSURE VALVE PIPING FOR MS-26, MS-40, MS-53**

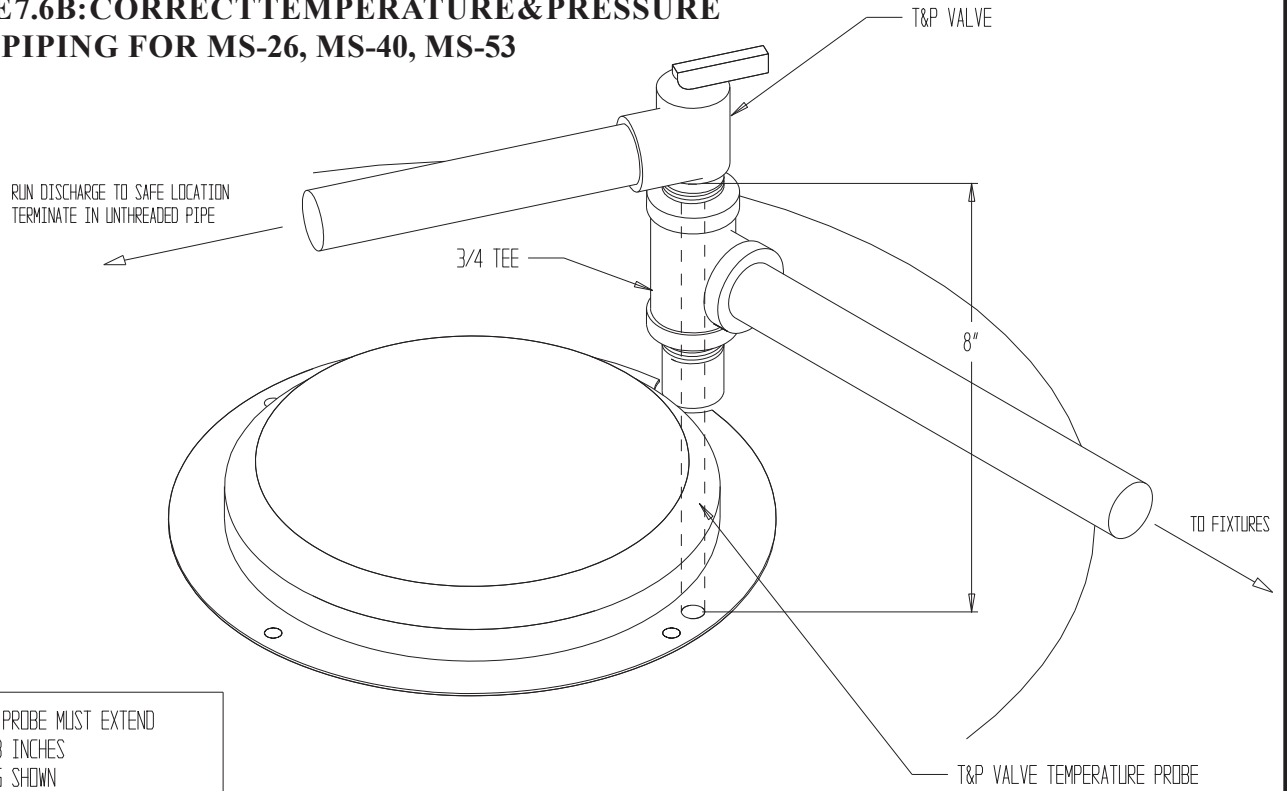

**FIGURE 7.6C: CORRECT TEMPERATURE & PRESSURE VALVE PIPING FOR MS-79, MS-119**

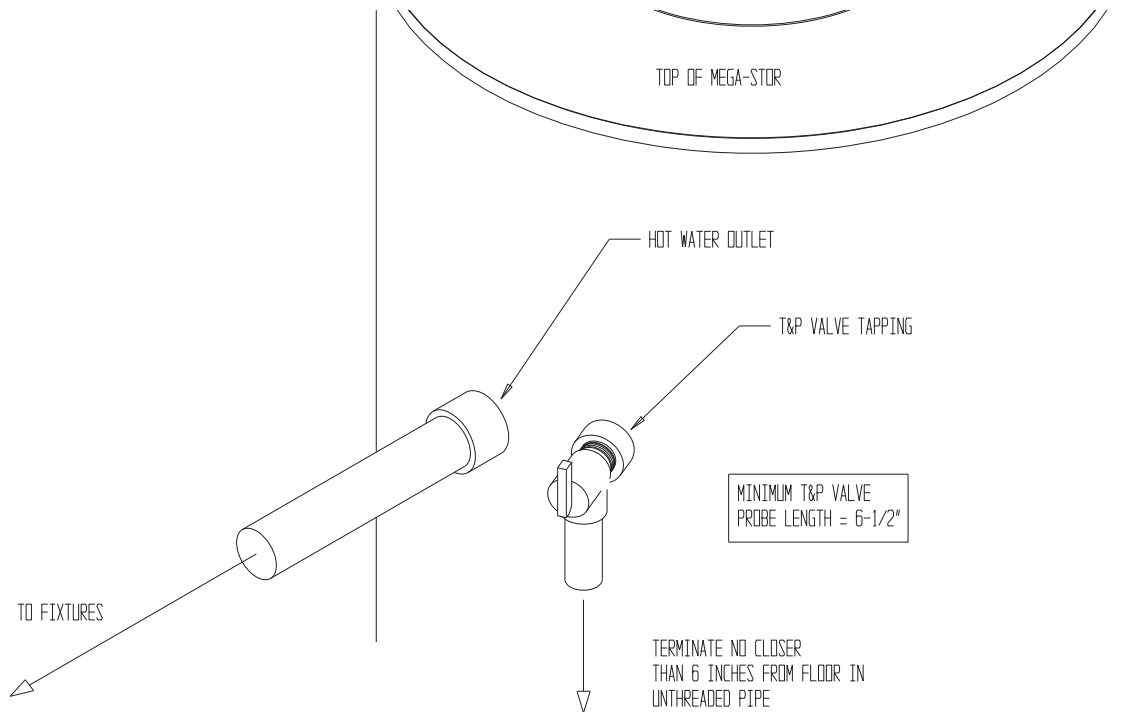

**FIGURE 7.8: DOMESTIC HOT WATER PIPING USING A MIXING VALVE**

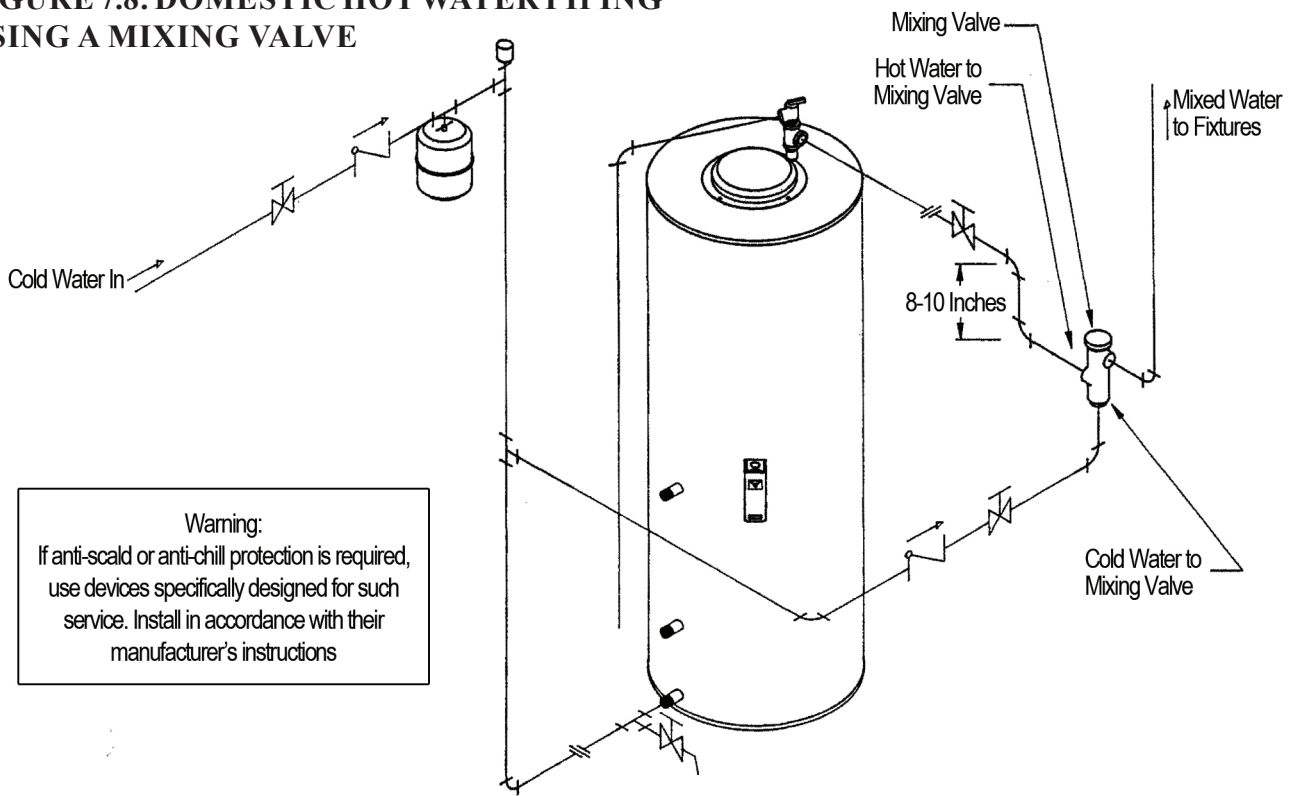

**FIGURE 7.9: DOMESTIC WATER PIPING FOR DISTANT FIXTURES USING A RECIRCULATION LINE**

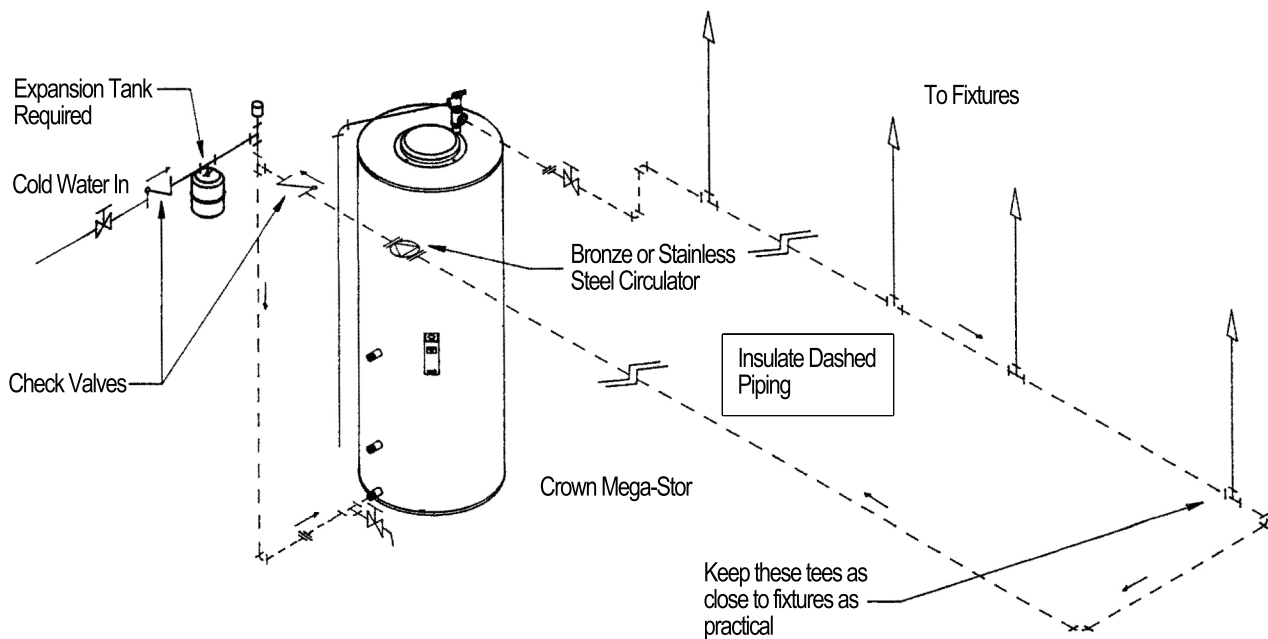

**FIGURE 7.10: DOMESTIC HOT WATER PIPING USING MULTIPLE MEGA-STORS**

COLD WATER IN

IMPORTANT:  
PRESSURE DROP THROUGH EACH MEGA-STOR  
BRANCH MUST BE EQUAL. THIS CAN BE  
DONE BY "REVERSE PIPING" THE TANKS AS SHOWN.

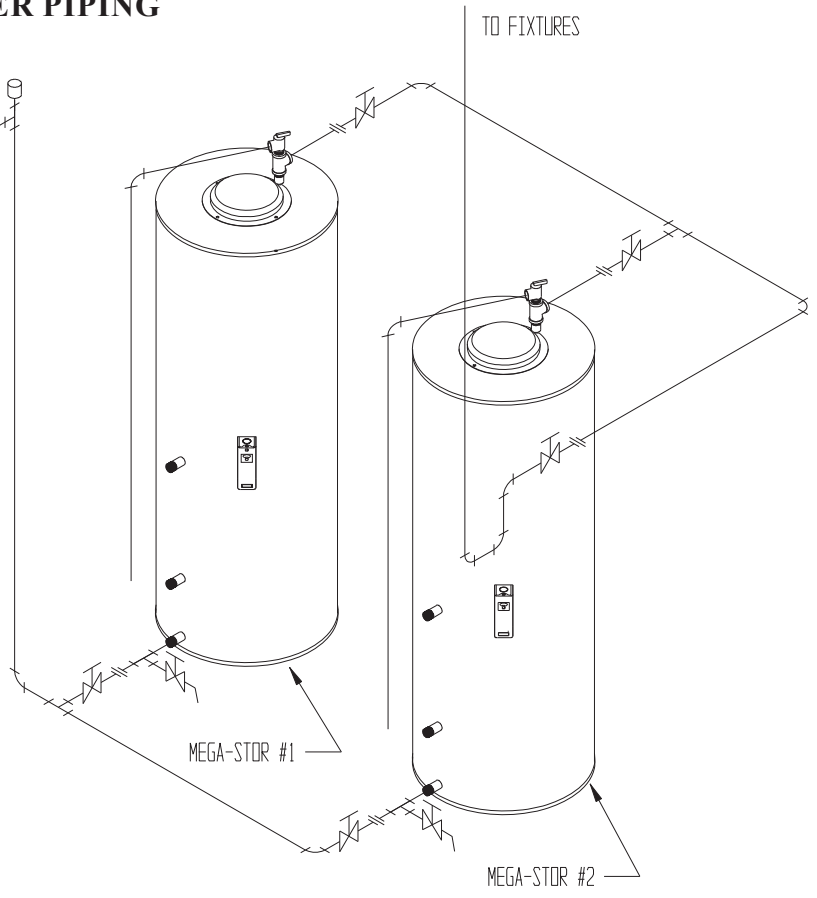

# VIII. WIRING

The following general notes apply to all wiring:

- 1) Wiring must be done in accordance with all codes. In the absence of any codes the system must be wired in accordance with the National Electric Code (ANSI/ZFPA 70-1990).
- 2) The Mega-Stor is equipped with Honeywell L4006A series temperature control. This control has a set of contacts which make upon a call for domestic water and break when this temperature is satisfied.

## CIRC ZONE WIRING (NON PRIORITY)

Figure 8.1 is a connections diagram for a non-priority circulator zone system using Honeywell R845A's. The R845A is equipped with two sets of contacts (3,4 and 5,6) which become made when the T and T terminals are made. Terminals 1 and 2 on the R845A are supplied with 110 VAC to power its internal transformer. In this application one R845A is provided for each zone including that of the Mega-Stor. If the boiler has a factory equipped circulator, this is disconnected from terminals C1 and C2 on the boiler.

When any thermostat (including the thermostat on the Mega-Stor) calls for heat, the relay in the R845A for that zone becomes energized. Terminals 3 and 4 become "made", energizing the circulator. Terminals 5 and 6 are also made which start the boiler.

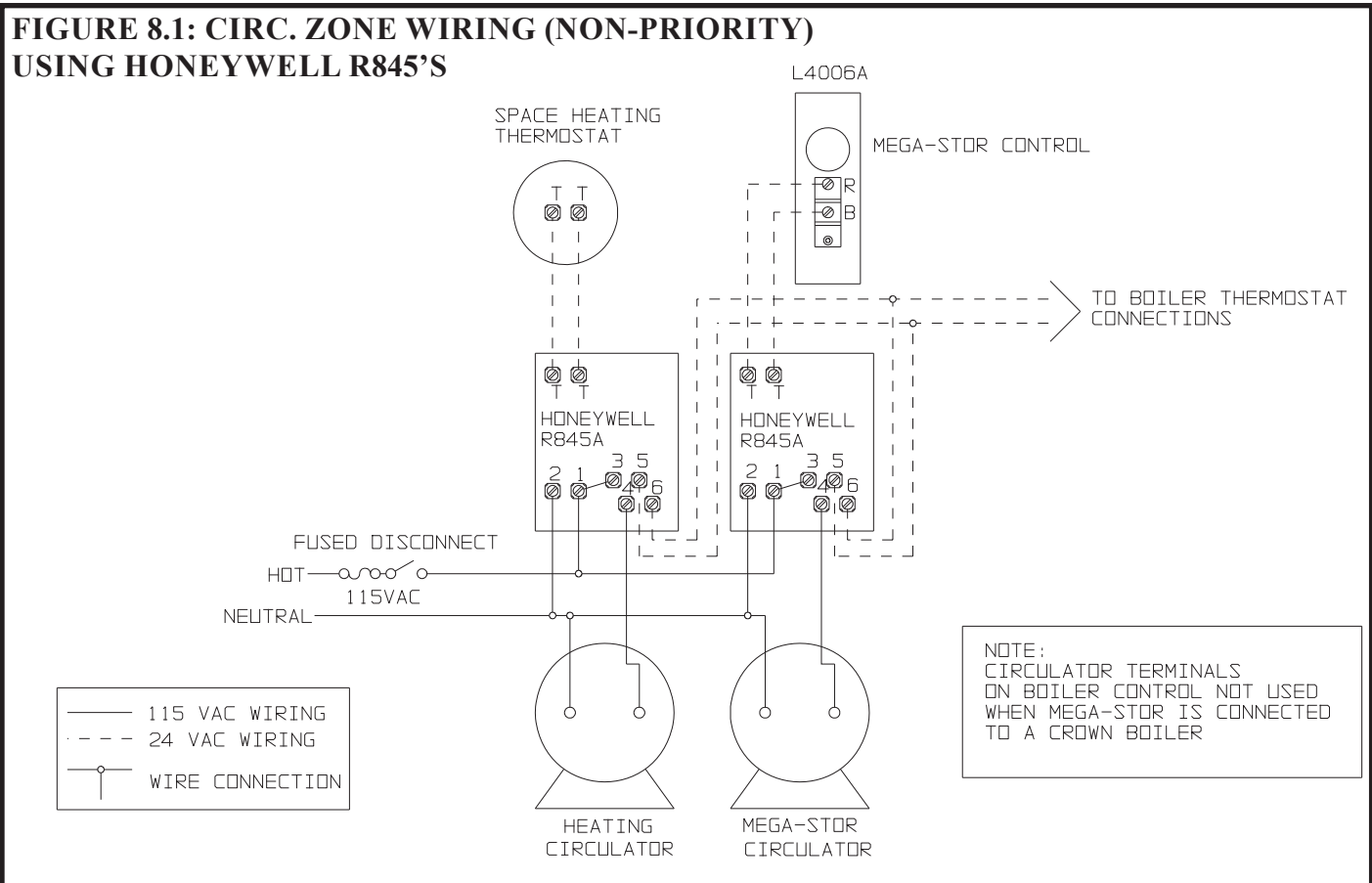

## **CIRCULATOR ZONE WIRING (PRIORITY)**

Figure 8.2 is a connections diagram for priority circulator zoning. This system is similar to non-priority circulator zoning except that a Honeywell R8285B relay is used in place of the R845A on the Mega-Stor zone. This relay is equipped with its own 24 volt transformer and D.P.D.T. contacts. The Mega-Stor control is connected to terminals R and G so that when the Mega-Stor control calls for heat the relay is energized.

One set of contacts on the R8285B is used to switch line voltage. On this set of contacts the common is connected to an unswitched “hot”. The normally closed contact is connected to terminal #1 on each of the space heating zone’s R845A’s. The normally open contact is connected to the Mega-Stor zone circulator.

The normally closed contact on the other set of R8285B contacts is not used. The common and normally open contacts are connected in parallel with terminals #5 and #6 on the space heating zone R845As.

As long as the Mega-Stor zone does not call for heat, the R845As for the heating zones have 110 VAC across their 1 and 2 terminals and the heating zones will function as described in the non-priority circulator zone section. As soon as the Mega-Stor calls for heat, however, the normally closed terminals in the R8285B open, de-energizing the heating zones and energizing the Mega-Stor circulator.

The other set of contacts in the R8285B (connected across the boiler thermostat connections) become “made” which brings on the boiler.

## **ZONE VALVES (NON PRIORITY)**

Figure 8.3 is a connections diagram for a zone system using Honeywell V8043F motorized zone valves. The motor on these valves is connected between TH and TR. TH/TR is provided for the electrician’s convenience as a binding post and is connected to nothing inside the valve. The “endswitch” terminals are connected to a set of switch contacts inside the valve which become made when the valve is open.

A call for heat from any thermostat or the Mega-Stor aquastat results in the application of 24 volts across the motor in that zone’s zone valve. This drives open the zone valve. When the valve has opened, the endswitch in that zone valve makes and brings on the boiler.

## **ZONE VALVES (2-WAY PRIORITY)**

Figure 8.4 is a connections diagram for a priority zone system using Honeywell V8043F motorized valves. An R8285B relay is used which is equipped with its own transformer and a set of S.P.D.T. contacts.

The Mega-Stor control is connected to terminals R and G on the R8285B so that when the Mega-Stor control calls for heat, the relay coil is energized. One side of the transformer is connected to the common contact. The normally closed contact is connected to all space heating thermostats. The normally open contact is connected directly to the Mega-Stor zone valve motor.

As long as the Mega-Stor is not calling for heat, power is supplied to all space heating thermostats and a call from any space heating thermostat will energize that zone’s zone valve and bring on the boiler. As soon as the Mega-stor calls for heat, however, the normally closed contacts, which supply all power to the space heating thermostats, open. This de-energizes the heating zones and closes any open space heating zone valves. At the same time, the normally open contacts in the R8285B become made which energizes the Mega-Stor zone valve. The Mega-Stor zone valve opens and its endswitch brings on the boiler.

If four or fewer zones (including the Mega-Stor zone) are present, the transformer in the R8285B may be used instead of an external transformer. Use terminals R and C with C being the “common” side of the 24 volt wiring.

**FIGURE 8.2: CIRCULATOR ZONING (PRIORITY)**

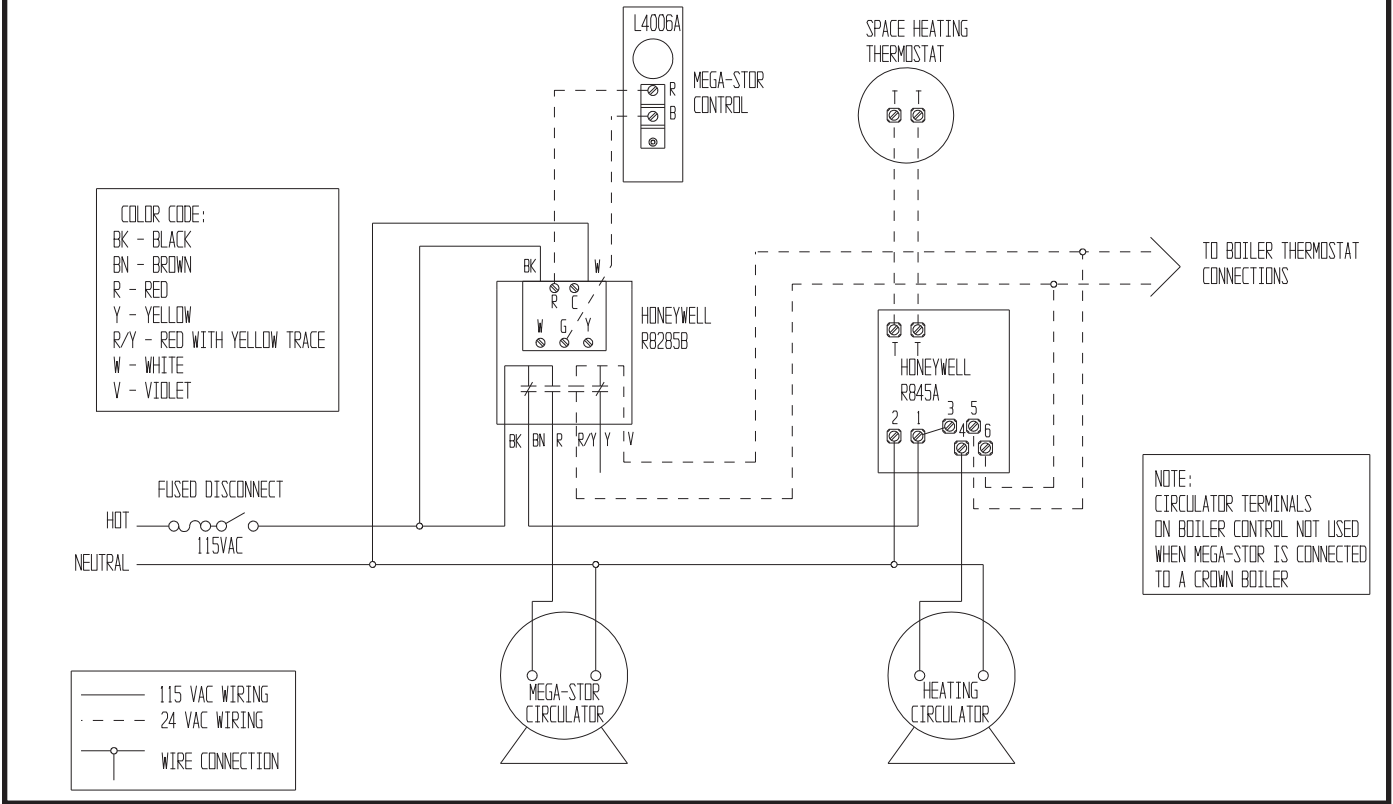

**FIGURE 8.3: ZONE VALVE WIRING (2-WAY VALVES, NON-PRIORITY)**

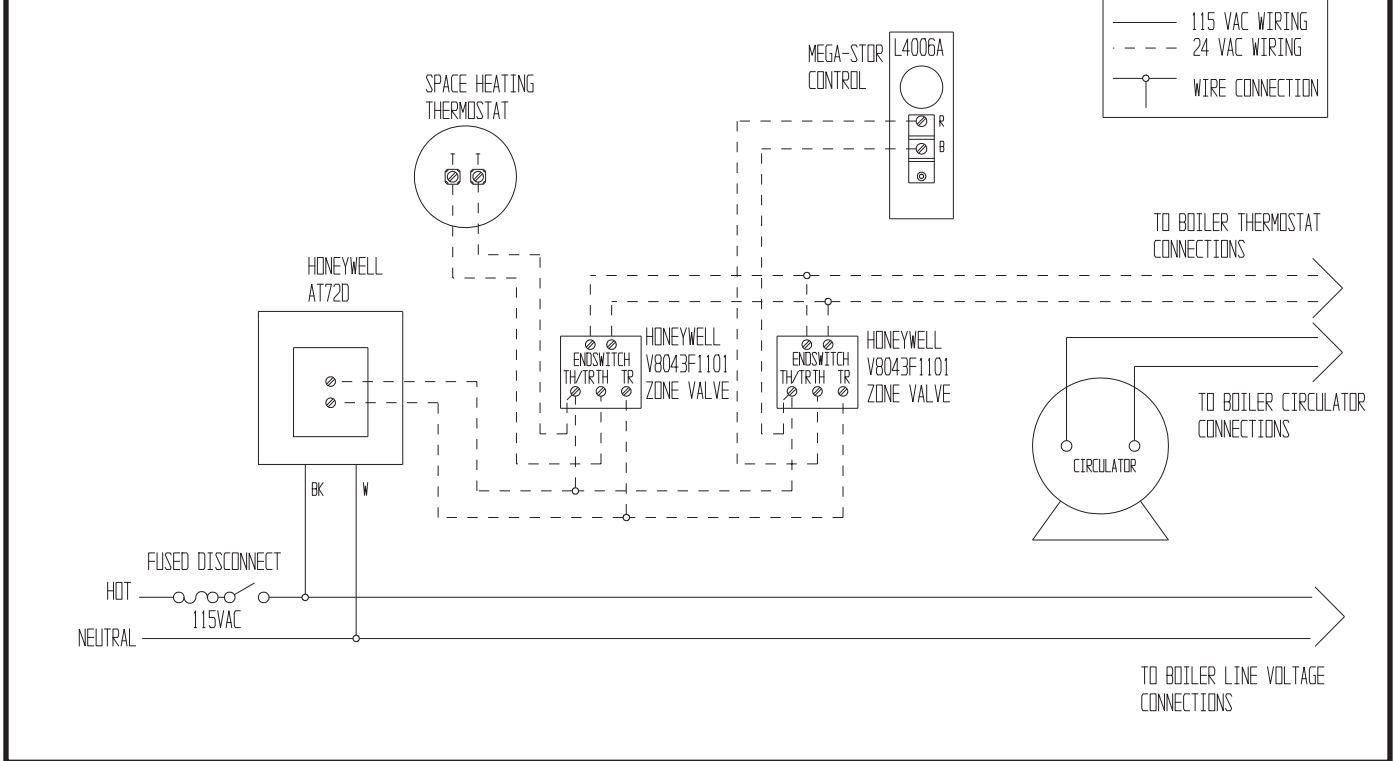

**FIGURE 8.4: ZONE VALVE WIRING  
(2-WAY VALVES, PRIORITY)**

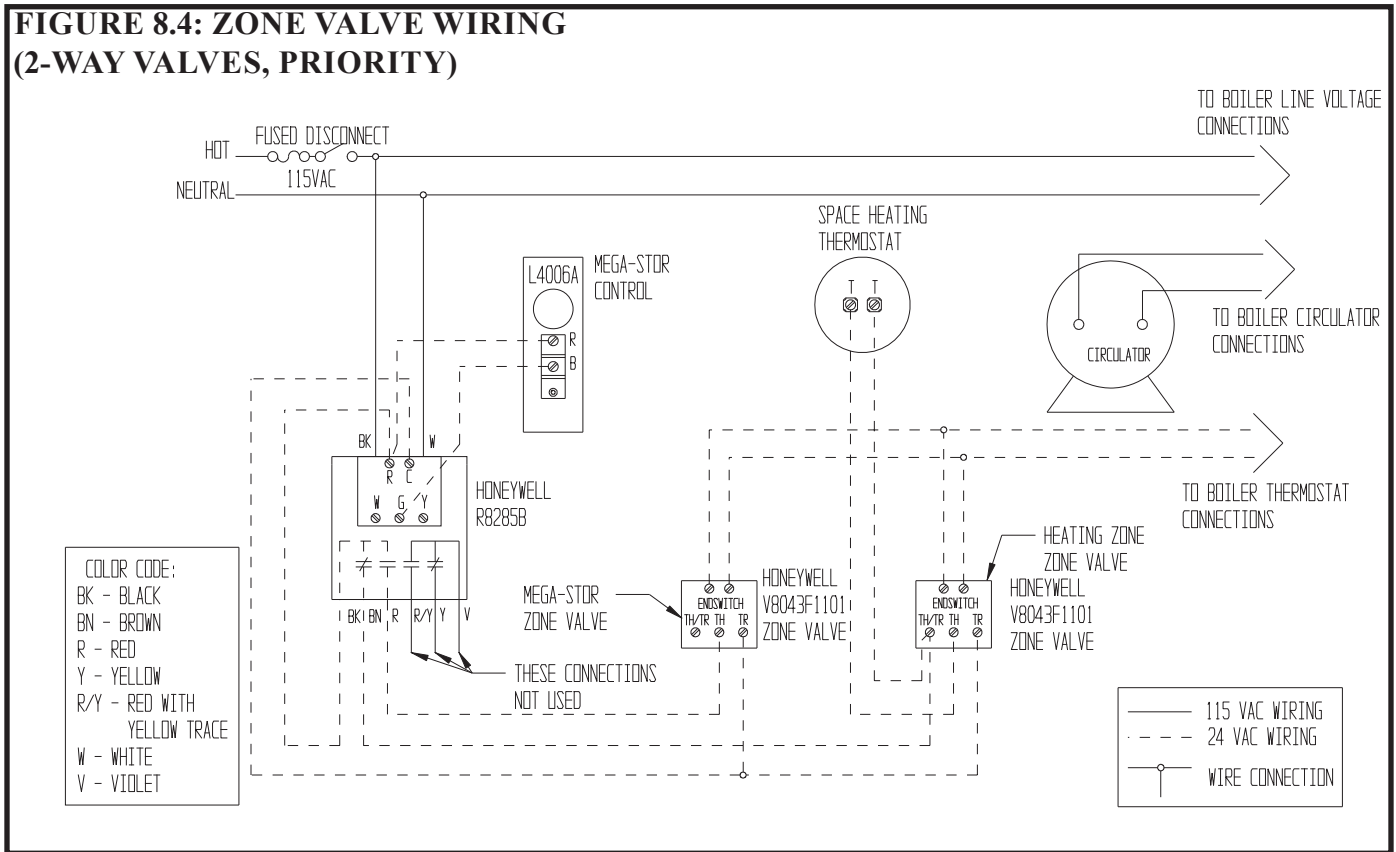

## IX. START-UP AND CHECK-OUT

- 1) Make sure that the system is free of leaks and that air is purged from the system.

### WARNING

Never attempt to fill a hot empty boiler

### IMPORTANT

Fix any leaks found before proceeding further. Leakage from the boiler piping can result in severe damage to the boiler.

- 2) Many soldering fluxes contain Zinc Chloride which can cause severe corrosion damage to stainless steel. After completing all domestic water connections, flush the Mega-Stor thoroughly before leaving the installation. This is particularly important if the Mega-Stor will be unused for an extended period of time after installation. Flush the Mega-Stor by drawing at least three times its volume from the tank.
- 3) Make sure that all electrical connections are correctly made and that no exposed high voltage wiring is present.
- 4) Temporarily disable the burner.
- 5) Make sure that each zone valve or circulator operates when, and only when, its thermostat calls for heat. Let each zone operate long enough to purge any remaining air from the system.
- 6) Re-enable the burner and allow the Mega-Stor zone to operate. Make sure that the Mega-Stor aquastat shuts down the zone when it is satisfied.
- 7) The setting of Mega-Stor aquastat temperature control determines the maximum water temperature in the tank. The differential of the control is a fixed 5°F with a 150°F maximum setting, set by the manufacturer to the lowest setting of 40°F.



For the most energy efficient operation, adjust the aquastat for the minimum water temperature necessary to meet domestic water needs. Because hot water presents a scald hazard, it is best to set the thermostat at 120°F or lower and raise it only if necessary to provide adequate hot water. See Table 9.2 for more information about scalding.

- a) Using a small flat screwdriver rotate the adjusting screw shown in Figure 9.1 until the desired temperature setting on the dial is aligned with the notch in the temperature indication window.
- b) After the water heater completes a heat-up cycle, check the water temperature at the faucet. Allow enough water to flow to ensure that the water temperature reflects the tank temperature. Adjust the water heater's temperature setting as necessary.
  - i) Adjusting to a lower temperature setting will not immediately affect the water temperature. Draw sufficient water or allow the water heater to sit until a heat-up cycle is initiated. Repeat steps a) and b).
  - ii) Adjusting to a higher temperature setting may not immediately affect the water temperature if a heat-up cycle begins, return to steps a) and b). If a heat-up cycle does not begin, draw sufficient water or allow the water heater to sit until a heat-up cycle is initiated. Repeat steps a) and b).

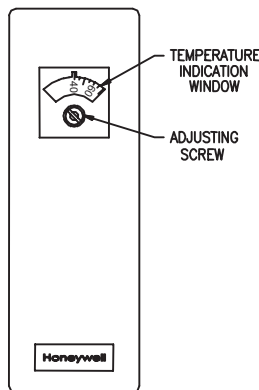

**FIGURE 9.1: TEMPERATURE CONTROL**

<b>APPROXIMATE TIME/TEMPERATURE RELATIONSHIPS FOR SCALDING</b>	
120°F	More than 5 minutes
125°F	1-1/2 to 2 minutes
130°F	About 30 seconds
135°F	About 10 seconds
140°F	Less than 5 seconds
145°F	Less than 3 seconds
150°F	About 1-1/2 seconds
155°F	About 1 second

**TABLE 9.2: SCALD RISK**

## X. MAINTENANCE

The Mega-Stor is an extremely simple device and as such requires very little maintenance. There are, however, several items which should be checked out on an annual or as needed basis to ensure a reliable supply of hot water:

- \* On an annual basis, remove the black cover over the handhole and make sure that the handhole cover is leak-tight.
- \* Make sure that the rest of the boiler and domestic water piping is free of leaks.
- \* If there is an oil lubricated circulator in the system, make sure that it is lubricated as called for by the circulator manufacturer.
- \* The Mega-Stor depends upon the boiler for a source of heat and is therefore only as reliable as the boiler. Make sure that the boiler is maintained in accordance with the boiler manufacturer's instructions.
- \* If a water treatment system is required to keep the water chemistry within the parameters shown in Table 5.1, make sure that this system is properly maintained.

# XI. PARTS

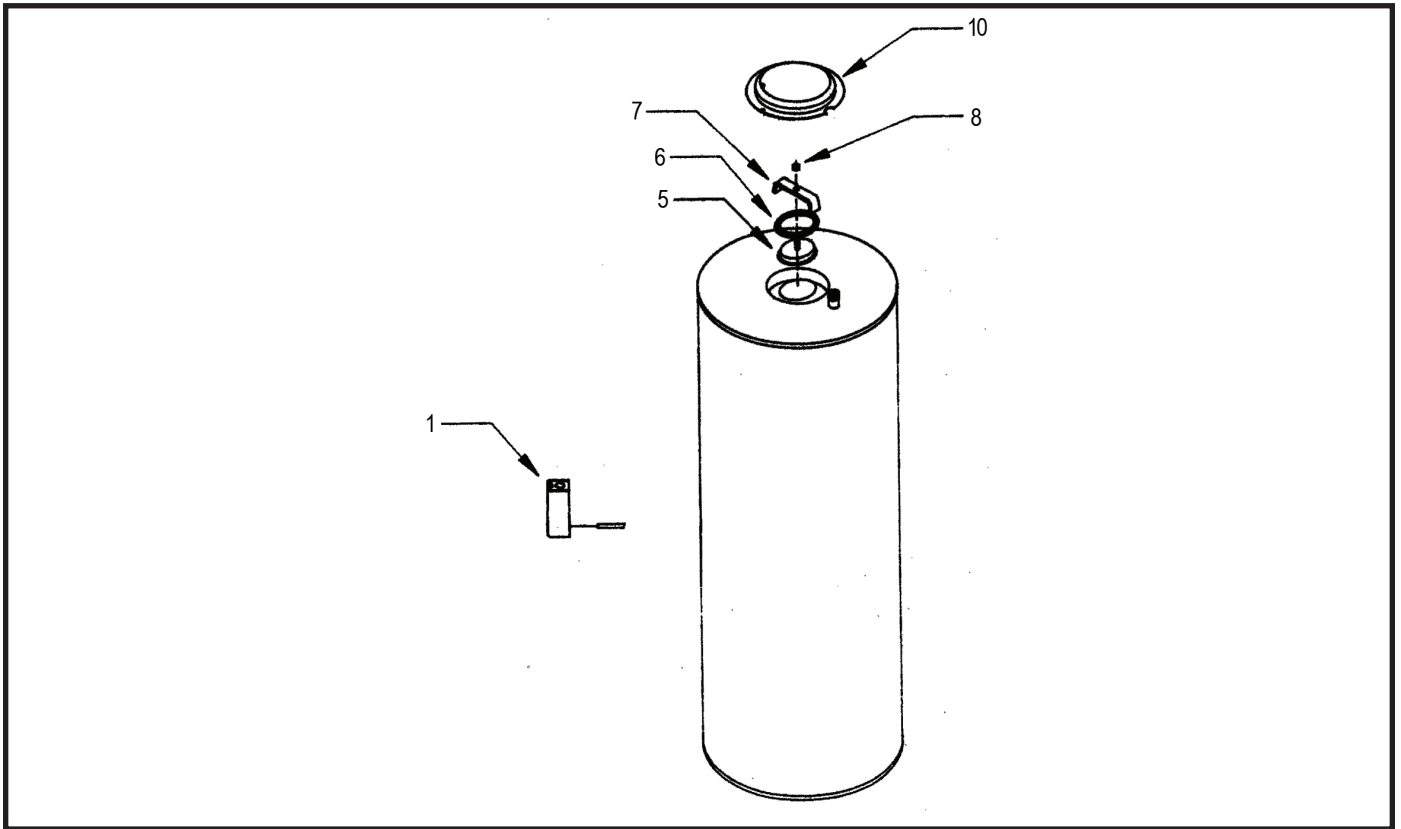

<u>Key #</u>	<u>Part #</u>	<u>Description</u>	<u>Qty./Tank</u>
1	35-3200	Thermostat (L4006A2114)	1
5	20-021	Handhole Cover	1
6	20-022	"O" Ring Gasket	1
7	20-023	Handhold Cover Bracket	1
8	90-025	M10 Nut	1
10	20-024*	Handhold Jacket Cover	1

**Notes:**

All part numbers are per item.

\*This part not used on MS-79 or MS-119





---

Manufacturer of Hydronic Heating Products  
P.O. Box 14818 3633 I. Street  
Philadelphia, PA 19134  
[www.crownboiler.com](http://www.crownboiler.com)