

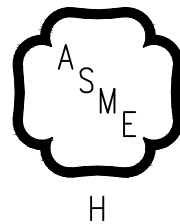
# Bali BWF Series

**Models:**

- BWF070CN
- BWF105CN
- BWF140CN
- BWF175CN
- BWF210CN
- BWF245CN
- BWF063CL
- BWF094CL
- BWF126CL
- BWF157CL
- BWF189CL
- BWF220CL

- Water Boiler
- Cast Iron
- Induced Draft
- Gas Fired

| Manual Contents  | Page |
|--|------|
| 1. Qualified Installer, Service Agency or Gas Supplier Read Before Proceeding . . . . .                        | 3    |
| 2. User/Homeowner Read Before Proceeding . . . . .   | 4    |
| 3. Specifications . . . . .  | 4    |
| 4. Locating the Boiler . . . . .   | 6    |
| 5. Preparing Boiler . . . . .  | 8    |
| 6. Air for Combustion and Ventilation . . . . .  | 8    |
| 7. Venting . . . . .   | 11   |
| 8. Water Piping . . . . .  | 22   |
| 9. Gas Piping . . . . .  | 26   |
| 10. Electrical . . . . .   | 27   |
| 11. Start-up and Checkout . . . . .  | 31   |
| 12. Operation . . . . .  | 36   |
| 13. Before Leaving Jobsite . . . . .   | 44   |
| 14. Service and Maintenance . . . . .  | 45   |
| 15. How It Works . . . . .   | 50   |
| 16. Troubleshooting . . . . .  | 52   |
| 17. Service Parts . . . . .  | 55   |
| Appendix A Direct Vent Installations . . . . .   | 64   |
| Appendix B Instructions for High Altitude Installations (US only) . . . . .                                    | 69   |
| Appendix C Low Water Return Temperatures . . . . .   | 71   |
| Appendix D Special Requirements For Side-Wall Vented Appliances In The Commonwealth of Massachusetts . . . . . | 73   |



**⚠ WARNING**

**Attention Installer** - Affix these instructions adjacent to boiler. Provide model number and serial number when seeking information and support.

**Attention Building Owner** - Retain these instructions for future reference. Contact a qualified installer, service agency or gas supplier for all issues and support.

**⚠ WARNING**

**Read these instructions carefully before installing.** This boiler must only be installed, serviced, or repaired by a qualified installer, service agency, or gas supplier. Improper installation, adjustment, alteration, service or maintenance can cause severe personal injury, death, or substantial property damage. For assistance or additional information, consult a qualified installer, service agency, or gas supplier.



The city of New York requires a Licensed Master Plumber supervise the installation of this product.

The Massachusetts Board of Plumbers and Gas Fitters has approved these boilers. See the Massachusetts Board of Plumbers and Gas Fitters website [https://licensing.reg.state.ma.us/public/pl\\_products/pb\\_pre\\_form.asp](https://licensing.reg.state.ma.us/public/pl_products/pb_pre_form.asp) for the latest Approval Code or ask your local Sales Representative.

The Commonwealth of Massachusetts requires this product to be installed by a licensed Plumber or Gas fitter.

**The following terms are used throughout this manual to bring attention to the presence of hazards of various risk levels, or to important information concerning product life.**

** DANGER**

**Indicates an imminently hazardous situation** which, if not avoided, will result in death, serious injury or substantial property damage.

** CAUTION**

**Indicates a potentially hazardous situation** which, if not avoided, may result in moderate or minor injury or property damage.

** WARNING**

**Indicates a potentially hazardous situation** which, if not avoided, may result in moderate or minor injury or property damage.

**NOTICE:** Indicates special instructions on installation, operation, or maintenance which are important but not related to personal injury hazards.

** DANGER**

**Explosion Hazard.** DO NOT store or use gasoline or other flammable vapors or liquids in the vicinity of this or any other appliance.

If you smell gas vapors, DO NOT try to operate any appliance - DO NOT touch any electrical switch or use any phone in the building. Immediately, call the gas supplier from a remotely located phone. Follow the gas supplier's instructions or if the supplier is unavailable, contact the fire department.

** WARNING**

**This boiler must only be serviced and repaired by skilled and experienced service technicians.**

- If any controls are replaced, they must be replaced with identical models.
- Read, understand and follow all the instructions and warnings contained in all the sections of this manual.
- If any electrical wires are disconnected during service, clearly label the wires and assure that the wires are reconnected properly.
- Never jump out or bypass any safety or operating control or component of this boiler.
- Assure that all safety and operating controls and components are operating properly before placing the boiler back in service.
- Annually inspect all vent gaskets and replace any exhibiting damage or deterioration.

# 1 Qualified Installer, Service Agency or Gas Supplier Read Before Proceeding

## DANGER

### Asphyxiation Hazard, Burn Hazard, Electrical Shock Hazard.

- Carefully read all instructions in literature packet and posted on boiler before attempting installation, startup, or service of this boiler. Perform steps in order given. Failure to follow all instructions in proper order could result in severe personal injury, death or substantial property damage.
- Use proper personal protective equipment when installing, servicing, or working near this boiler. Materials of construction, flue products, and fuel contain alumina, silica, heavy metals, carbon monoxide, nitrogen oxides, and/or other toxic or harmful substances that can be hazardous to health and life and that are known to the State of California to cause cancer, birth defects, and other reproductive harm.
- Do not disconnect pipe fittings on boiler or in heating system without first verifying system is cool and free of pressure and that your clothing will protect you from a release of hot water or steam. Do not rely solely on boiler temperature and pressure gauge when making this judgement.
- Install all guards, cover plates, and enclosures before leaving boiler in operation.
- Disconnect electrical supply before installing or performing maintenance.

### NOTICE:

1. Size boiler properly. A grossly oversized boiler will cycle excessively leading to premature failure of boiler and its components. Warranty does not cover damage from excessive cycling.
2. Systems employing baseboard and/or radiators, use an industry accepted sizing method such as the I=B=R Guide published by Air Conditioning Contractors of America (ACCA).
3. Inspect shipment carefully for signs of damage. Any claim for damage or shortage in shipment must be filed immediately against carrier by consignee. No claims for variances or shortages will be allowed by boiler manufacturer, **unless presented within 60 days after receipt of equipment.**

## 2 User/Homeowner Read Before Proceeding

### WARNING

#### Asphyxiation Hazard. Fire Hazard.

- A qualified installer, service agency or gas supplier should annually inspect boiler.
- If you are not qualified to install or service boilers, do not install or service this one.
- Carbon monoxide is an odorless, deadly gas that may be introduced into your home by any malfunctioning fuel burning product or vent system failure. The installer must verify that at least one carbon monoxide alarm has installed with a residential living space or home following the alarm manufacturer's instructions and applicable local codes before putting the appliance into operation. Consider installing CO alarms near bedrooms in all levels of building to warn you and your family of potential CO exposure..
- Do not block air flow into or around boiler or opening for fresh air into boiler room. Insufficient air may cause the boiler to produce carbon monoxide or start a fire.

**NOTICE:** Protect your home in freezing weather. A power outage, operating control, or component failure will prevent your boiler from lighting. In winter your pipes may freeze and cause extensive property damage. Do not leave heating system unattended during cold weather unless alarms or other safeguards are in place to prevent such property damage.

### CAUTION

#### Burn Hazard.

Keep children and pets away from hot surfaces of the boiler including boiler piping, vent piping, and vent terminals.

**NOTICE:** Boiler may leak water or steam at the end of its useful life. Be sure to protect walls, carpets, and valuables from water or steam that could leak from boiler.

**NOTICE:** This boiler contains controls which may cause the boiler to shut down and not restart without service. If damage due to frozen pipes is a possibility, heating system should not be left unattended in cold weather; or appropriate safeguards and alarms should be installed on heating system to prevent damage if boiler is inoperative.

## 3 Specifications



Table 3-1: Ratings

| Model Number | Fuel     | AFUE% | Input (MBH) <sup>(1)</sup> | Heating Capacity (MBH) | Net AHRI Rating, Water <sup>(2)</sup> (MBH) |
|--------------|----------|-------|----------------------------|------------------------|---|
| BWF070CN     | Nat. Gas | 85.0  | 70                         | 60                     | 52  |
| BWF105CN     | Nat. Gas | 85.0  | 105                        | 90                     | 78  |
| BWF140CN     | Nat. Gas | 85.0  | 140                        | 120                    | 104   |
| BWF175CN     | Nat. Gas | 85.0  | 175                        | 150                    | 130   |
| BWF210CN     | Nat. Gas | 85.0  | 210                        | 179                    | 156   |
| BWF245CN     | Nat. Gas | 84.0  | 245                        | 208                    | 181   |
| BWF063CL     | Propane  | 85.0  | 63                         | 54                     | 47  |
| BWF094CL     | Propane  | 85.0  | 94.5                       | 81                     | 70  |
| BWF126CL     | Propane  | 85.0  | 126                        | 108                    | 94  |
| BWF157CL     | Propane  | 85.0  | 157.5                      | 135                    | 117   |
| BWF189CL     | Propane  | 85.0  | 189                        | 161                    | 140   |
| BWF220CL     | Propane  | 84.0  | 220.5                      | 187                    | 163   |

<sup>(1)</sup> Input ratings can be used for elevations up to 2,000 ft. above sea level. Refer to Appendix B for elevations 2,000 ft. or higher.

<sup>(2)</sup> Net AHRI Water Ratings shown are based on a piping and pickup allowance of 1.15. Consult manufacturer before selecting boiler for installations having unusual piping and pickup requirements, such as intermittent system operation, extensive piping systems, etc.

**Maximum Allowable Working Pressure - 50 psi. Boiler shipped from factory with a 30 psi safety relief valve.**

**Electrical Requirements: 120 VAC, 60 Hz, less than 12A**

### 3 Specifications *(continued)*

**Table 3-2: Dimensions and Connections**

| Boiler Model | # of Sections | Depth (in.) | Width (in.) | Height (in.) | Gas (NPT) | Vent (in.) | Supply NPT | Return NPT | Relief Valve NPT | Drain Valve NPT | Maximum Allowable Working Pressure (PSI) |
|--------------|---------------|-------------|-------------|--------------|-----------|------------|------------|------------|------------------|-----------------|--|
| BWF070CN     | 3             | 26-1/2      | 12-3/4      | 37-3/4       | 1/2       | 3          | 1-1/4      | 1-1/4      | 3/4              | 3/4             | 50                                       |
| BWF105CN     | 4             | 26-1/2      | 15-1/2      | 37-3/4       | 1/2       | 3          | 1-1/4      | 1-1/4      | 3/4              | 3/4             | 50                                       |
| BWF140CN     | 5             | 26-1/2      | 18-1/2      | 37-3/4       | 1/2       | 3          | 1-1/4      | 1-1/4      | 3/4              | 3/4             | 50                                       |
| BWF175CN     | 6             | 26-1/2      | 21-1/2      | 37-3/4       | 1/2       | 3          | 1-1/4      | 1-1/4      | 3/4              | 3/4             | 50                                       |
| BWF210CN     | 7             | 26-1/2      | 24-3/4      | 37-3/4       | 3/4       | 3          | 1-1/4      | 1-1/4      | 3/4              | 3/4             | 50                                       |
| BWF245CN     | 8             | 26-1/2      | 27-3/4      | 37-3/4       | 3/4       | 4          | 1-1/4      | 1-1/4      | 3/4              | 3/4             | 50                                       |
| BWF063CL     | 3             | 26-1/2      | 12-3/4      | 37-3/4       | 1/2       | 3          | 1-1/4      | 1-1/4      | 3/4              | 3/4             | 50                                       |
| BWF094CL     | 4             | 26-1/2      | 15-1/2      | 37-3/4       | 1/2       | 3          | 1-1/4      | 1-1/4      | 3/4              | 3/4             | 50                                       |
| BWF126CL     | 5             | 26-1/2      | 18-1/2      | 37-3/4       | 1/2       | 3          | 1-1/4      | 1-1/4      | 3/4              | 3/4             | 50                                       |
| BWF157CL     | 6             | 26-1/2      | 21-1/2      | 37-3/4       | 1/2       | 3          | 1-1/4      | 1-1/4      | 3/4              | 3/4             | 50                                       |
| BWF189CL     | 7             | 26-1/2      | 24-3/4      | 37-3/4       | 3/4       | 3          | 1-1/4      | 1-1/4      | 3/4              | 3/4             | 50                                       |
| BWF220CL     | 8             | 26-1/2      | 27-3/4      | 37-3/4       | 3/4       | 4          | 1-1/4      | 1-1/4      | 3/4              | 3/4             | 50                                       |

**Table 3-3: Weights and Volume**

| Boiler Model | Water Content (gal) | Approx. Shipping Weight (lbs) | Optional Direct Vent Conversion Kit (PN) | Shipping Crate Depth (in.) | Shipping Crate Width (in.) | Shipping Crate Height (in.) | Heat Exchanger Surface Area (ft. <sup>2</sup> ) |
|--------------|---------------------|-------------------------------|--|----------------------------|----------------------------|-----------------------------|---|
| BWF070CN     | 2                   | 260                           | 110019-03                                | 39                         | 26                         | 47                          | 7.72  |
| BWF105CN     | 3                   | 310                           | 110019-04                                | 39                         | 26                         | 47                          | 11.58   |
| BWF140CN     | 4                   | 360                           | 110019-05                                | 39                         | 26                         | 47                          | 15.44   |
| BWF175CN     | 5                   | 415                           | 110019-06                                | 39                         | 26                         | 47                          | 19.31   |
| BWF210CN     | 6                   | 470                           | 110019-07                                | 39                         | 35                         | 47                          | 23.17   |
| BWF245CN     | 7                   | 525                           | 110019-08                                | 39                         | 35                         | 47                          | 27.03   |
| BWF063CL     | 2                   | 260                           | 110019-03                                | 39                         | 26                         | 47                          | 7.72  |
| BWF094CL     | 3                   | 310                           | 110019-04                                | 39                         | 26                         | 47                          | 11.58   |
| BWF126CL     | 4                   | 360                           | 110019-05                                | 39                         | 26                         | 47                          | 15.44   |
| BWF157CL     | 5                   | 415                           | 110019-06                                | 39                         | 26                         | 47                          | 19.31   |
| BWF189CL     | 6                   | 470                           | 110019-07                                | 39                         | 35                         | 47                          | 23.17   |
| BWF220CL     | 7                   | 525                           | 110019-08                                | 39                         | 35                         | 47                          | 27.03   |

## 4 Locating Boiler

### Code Requirements

1. Installations must conform to requirements of authority having jurisdiction or, in the absence of such requirements, to *National Fuel Gas Code*, ANSI Z223.1/NFPA 54.
2. All wiring must comply with *National Electrical Code* NFPA 70.
3. Where required by authority having jurisdiction, installation must conform to *Standard for Controls and Safety Devices for Automatically Fired Boilers*, ASME CSD-1.

### Location Considerations

1. Provide combustion and ventilation air in accordance with the *National Fuel Gas Code*, ANSI Z223.1/NFPA 54, or applicable provisions of local building codes.
2. If replacing an existing boiler, check for and correct common system problems including:
  - A. System leaks resulting in premature heat exchanger failure from oxygen corrosion or hardness deposits.
  - B. Inadequate freeze protection resulting in system freezing and leaking.
  - C. Dirt or debris left in existing piping if it has not been properly flushed or cleaned.
3. Appliance is listed for installation on combustible flooring and must not be installed on carpeting.
4. Install on level floor. For basement installation provide concrete base if floor is not level or if water may be encountered on floor around boiler.
5. Protect gas ignition system components from water (dripping, spraying, etc.) during appliance operation and service.
6. Locate boiler to avoid water damage in case there is a leak. If boiler must be located in an area sensitive to water damage, install drain pan underneath boiler and pipe to a suitable drain location. Manufacturer will not be held responsible for water damage resulting from this appliance or any of its components.
7. Check for and remove any combustible materials, gasoline, or other flammable liquids from area around boiler.
8. Check for and remove any potential combustion air contaminants from area around boiler. See Table 4-1.

**NOTICE:** Flue side corrosion caused by contaminants is not covered by warranty.

**Table 4-1: Corrosive Combustion Contaminants and Sources**

|   |
|---|
| Contaminants to avoid:  |
| Spray cans containing chloro/fluorocarbons (CFC's)  |
| Permanent wave solutions  |
| Chlorinated waxes/cleaners  |
| Chlorine-based swimming pool chemicals  |
| Calcium chloride used for thawing   |
| Sodium chloride used for water softening  |
| Refrigerant leaks   |
| Paint or varnish removers   |
| Hydrochloric acid/muriatic acid   |
| Cements and glues   |
| Antistatic fabric softeners used in clothes dryers  |
| Chlorine-type bleaches, detergents, and cleaning solvents found in household laundry rooms. |
| Adhesives used to fasten building products and other similar products                       |
| Excessive dust and dirt   |

|  |
|--|
| Areas likely to have contaminants:             |
| Dry cleaning/laundry areas and establishments  |
| Swimming pools                                 |
| Metal fabrication plants                       |
| Beauty shops                                   |
| Refrigeration repair shops                     |
| Photo processing plants                        |
| Auto body shops                                |
| Plastic manufacturing plants                   |
| Furniture refinishing areas and establishments |
| New building construction                      |
| Remodeling areas                               |
| Garages with workshops                         |

### Clearances

1. Provide clearances between boiler jacket and combustible material in accordance with authority having jurisdiction. Minimum clearances to combustible material shown in Figure 4-2.
2. **Recommend 24 in. service clearance from left side, right side and front.**  
**NOTICE:** If recommended service clearances are not provided, it may be necessary to remove boiler for service.
3. Boiler must not be installed on carpeting.

## 4 Locating Boiler *(continued)*

### Before Removing Existing Boiler

Take pictures and measure and/or mark existing steam and condensate return piping to ensure proper re-piping of new boiler. Support existing piping before disconnecting to prevent change in pitch.

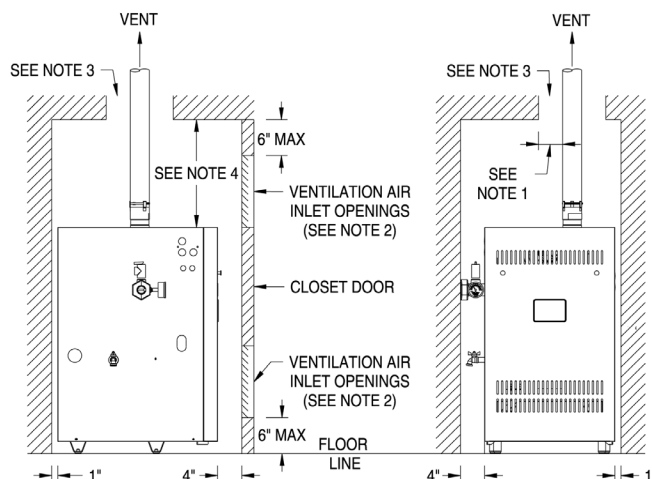
### After Removing Existing Boiler

When an existing boiler is removed from a common venting system, the common venting system is likely to be too large for proper venting of appliances remaining connected to it.

At time of removal of an existing boiler, the following steps must be followed with each appliance remaining connected to the common venting system placed in operation, while the other appliances remaining connected to the common venting system are not in operation:

1. Seal any unused openings in the common venting system.
2. Visually inspect venting system for proper size and horizontal pitch and determine there is no blockage or restriction, leakage, corrosion, and other deficiencies which could cause an unsafe condition.

3. Insofar as is practical, close all building doors and windows and all doors between the space in which the appliances remaining connected to the common venting system are located and other spaces of building. Turn on clothes dryers and any appliance not connected to the common venting system. Turn on any exhaust fans, such as range hoods and bathroom exhausts, so they will operate at maximum speed. Do not operate a summer exhaust fan. Close fireplace dampers.
4. Place in operation appliance being inspected. Follow Operating Instructions. See Figure 11-3. Adjust thermostat so appliance will operate continuously.
5. Test for spillage at draft hood relief opening after 5 minutes of main burner operation. Use flame of a match or candle, or smoke from a cigarette, cigar or pipe.
6. After it has been determined that each appliance remaining connected to the common venting system properly vents when tested as outlined above, return doors, windows, exhaust fans, fireplace dampers and any other gas-burning appliance to their previous condition of use.
7. Any improper operation of the common venting system must be corrected so the installation conforms with the *National Fuel Gas Code*, ANSI Z223.1/NFPA 54. When resizing any portion of the common venting system, the common venting system must be resized to approach minimum size as determined using appropriate tables in the *National Fuel Gas Code*, ANSI Z223.1/NFPA 54.



#### NOTES:

1. VENT PIPE MINIMUM CLEARANCE TO COMBUSTIBLE MATERIAL IS 4" WHEN VENT IS INSTALLED IN A FULLY ENCLOSED CHASED APPLICATION OR 3" WHEN VENT IS INSTALLED WITH AT LEAST ONE SIDE OPEN, SIMILAR TO A JOIST BAY APPLICATION.
2. AREA OF EACH OPENING, 1 SQ. INCH FOR EACH 1000 BTUH INPUT WITH MINIMUM OF 100 SQ. INCHES. HEIGHT OF OPENING SHOULD BE HALF THE WIDTH.
3. USE DOUBLE WALL THIMBLE WHEN PENETRATING A COMBUSTIBLE WALL.
4. 18" CLEARANCE REQUIRED FOR CLOSET INSTALLATION.  
4" CLEARANCE REQUIRED FOR ALCOVE OR OPEN INSTALLATION.

**Figure 4-2: Minimum Clearances to Combustible Construction**

### **WARNING**

Adequate combustion and ventilation air must be provided to assure proper combustion.

## 5 Preparing Boiler

### DANGER

Use precautions and appropriate rigging apparatus when moving heavy objects.

### CAUTION

Do not drop boiler. Do not bump boiler jacket against floor.

### Unpack boiler

1. Move boiler to approximate installed position.
2. Remove all crate fasteners.
3. Lift outside container and remove with all other inside protective spacers and bracing. Save two of the wooden slats from the container sleeve for use in Steps 5 and 6.
4. Remove all boiler hold-down fasteners.
5. Tilt the boiler to one side and slide a wooden slat under the two raised feet.
6. Tilt the boiler to the other side and slide another wooden slat under the two raised feet.
7. Slide the boiler forward or backward off the skid using the two wooden slats as runners.
8. Move boiler to its permanent location.

## 6 Air for Combustion and Ventilation

**NOTICE:** If combustion air is being brought to this boiler using one of the Direct Vent Conversion Kits shown in Table 3-3, requirements in Section 6 do not apply. See Appendix A for combustion and ventilation air requirements.

### WARNING

INSUFFICIENT COMBUSTION AIR SUPPLY may result in the production and release of deadly carbon monoxide (CO) into the home.

### WARNING

PROVIDE ENOUGH AIR to ventilate the boiler room and sustain combustion. Ignition failure, overheating, fire, carbon monoxide, and spillage of flue gases may result from poor air supply.

### WARNING

Do not install this boiler in areas where it will draw combustion air from areas where chemicals, such as bleaches, fabric softeners, paints, cleaners, refrigerants, and cat boxes are used or stored. Do not draw combustion air containing large amounts of dust such as that generated by dry wall construction or woodworking. Failure to observe this warning could result in objectionable odors, severe boiler damage, personal injury or loss of life.

Provide provisions for combustion and ventilation air in accordance with the section "Air for Combustion and Ventilation," of the National Fuel Gas Code, ANSI Z223.1/NFPA 54, or Clause 8.2, 8.3 or 8.4 of Natural Gas and Propane Installation Code, CAN/CSA B149.1, or applicable provisions of the local building codes.

In almost all cases, one of the following two techniques will be best for supplying this boiler with adequate fresh air:

Indoor Combustion Air – Combustion air is drawn into the boiler room from other parts of the building and from outdoors through natural infiltration (cracks under doors, etc). **This method cannot be used in all cases – see discussion below.**

Direct Venting – Combustion air is pulled directly from outside using the appropriate Direct Vent Conversion Kit shown in Table 3-3 with installer supplied PVC or galvanized air intake piping. See Appendix A for details on installing this boiler with a direct vent system.

## 6 Air for Combustion and Ventilation *(continued)*

The *National Fuel Gas Code* does describe some other acceptable techniques for bringing outdoor combustion air to the boiler room, but these should rarely be needed and are not discussed here.

### 1. Using the Indoor Combustion Air Method

- A. Total the input of all appliances in the boiler room in thousands of BTU/hr.
- B. Find the volume of the boiler room in cubic feet:

$$\text{Volume (ft}^3\text{)} = \text{Length (ft.)} \times \text{Width (ft.)} \times \text{Height (ft.)}$$

If the boiler room adjoins another room and there is no door present between these two rooms, add the volumes of the rooms together. Repeat for any other connected rooms which do not have doors. **Do not add the volume of two rooms separated by a door even if that door is “always left open”:**

- C. Divide the volume obtained in Step 2 by the input calculated in Step 1.
- D. If the result is at least 50 ft<sup>3</sup> per 1,000 BTU/hr., and none of the conditions described in (6) below are met, normal infiltration should provide adequate fresh air into the boiler room.
- E. If the result is less than 50 ft<sup>3</sup> per 1,000 BTU/hr., provide two openings into the boiler room, one near the floor and one near the ceiling. The top edge of the upper opening must be within 6 in. of the ceiling and the bottom edge of the lower opening must be within 6 in. of the floor (Figure 6-1):
  - For rooms that are both on the same floor, each opening must have a free area of 1 square inch per 1,000 BTU/hr. input of all gas burning appliances in the boiler room.
  - For rooms that are not all on the same floor (such as a boiler room and adjoining hall with stairway), each opening must have a free area of 2 square inches per 1,000 BTU/hr. input of all gas burning appliances in the boiler.
  - The minimum opening dimension is 3 inches. Minimum opening free area is 100 square inches per opening.

- If the total volume of both the boiler room and the room to which the openings connect is less than 50 cubic feet per 1,000 BTU/hr. of total appliance input, install a pair of identical openings into a third room. Connect additional rooms with openings until the total volume of all rooms is at least 50 cubic feet per 1,000 BTU/hr. of input. Note that if any of the connected rooms, is on a different floor, each of the two openings between all connected rooms must have a free area of 2 square inches per 1,000 BTU/hr. of input.
  - The “free area” of an opening takes into account the blocking effect of mesh, grills, and louvers. Where screens are used, they must be no finer than ¼ in. (4 x 4) mesh.
  - If providing openings into adjacent rooms is undesirable, use the Direct Vent Conversion Kit.
- F. Do not use the Indoor Combustion Air Method described above if any of the following are true:
- i. The indoor space is so tightly constructed that the number of air changes per hour is known to be 0.4 or less.
  - ii. The boiler room is depressurized relative to the outdoors. This depressurization is possible if the structure is tightly constructed and/or is equipped with exhaust fans.
  - iii. The building is known to be of unusually tight construction, which is defined here as construction having all of the following characteristics:
    - Walls exposed to the outdoor atmosphere having a continuous water vapor retarder with a rating of 1 perm or less with openings gasketed or sealed.
    - Openable windows and doors are weather stripped.
    - Caulking or sealants are applied to areas, such as joints around window and door frames, between sole plates and floors, between wall-ceiling joints, between wall panels, at penetrations for plumbing, electrical and gas lines and at other openings.

## 6 Air for Combustion and Ventilation *(continued)*

Example:

A 105,000 BTU/hr. input boiler and a water heater are to be installed in a room measuring 6 ft. - 3 in. x 7 ft. with an 8 ft. ceiling. The water heater has an input of 30,000 BTU/hr.

Total input in thousands of BTU/hr. =  
 $(105,000 \text{ BTU/hr.} + 30,000 \text{ BTU/hr.}) \div 1,000$   
 = 135

Volume of room = 6.25 ft. x 7 ft. x 8 ft. = 350 ft<sup>3</sup>

$350 \div 135 = 2.59$ . Since 2.59 is less than 50, there will be an inadequate fresh air supply in the boiler room unless openings are installed between the boiler room and at least one adjacent room. It turns out that the boiler room in this example is adjacent to a full basement which is 20 ft. x 45 ft. x 8 ft. high. If two openings are installed into this basement that each have a free area of 135 in<sup>2</sup>, the combined volume of the boiler room and basement will be:

$350 \text{ ft}^3 + 6,400 \text{ ft}^3 = 6,750 \text{ ft}^3$  and:  
 $6,750 \div 135 = 50 \text{ ft}^3$  per 1,000 BTU/hr.

In the absence of one of the conditions described in (6) above, this arrangement should provide an adequate fresh air supply to all the appliances in the boiler room.

### 2. Using Outdoor Combustion Air ("Direct Venting")

This method requires the Direct Vent Conversion Kit shown in Table 3-3. Appendix A describes how to size and run the intake pipe.

Although combustion air is supplied through the air intake piping, ventilation air is still required around the boiler to prevent overheating of boiler components. If the boiler is installed in a closet, provide two openings in the closet, each having a net free area of 100 square inches as shown in Figure 6-1. Note that these openings are independent of the boiler size. Additional area may be required if other fuel burning appliances are installed in this closet.

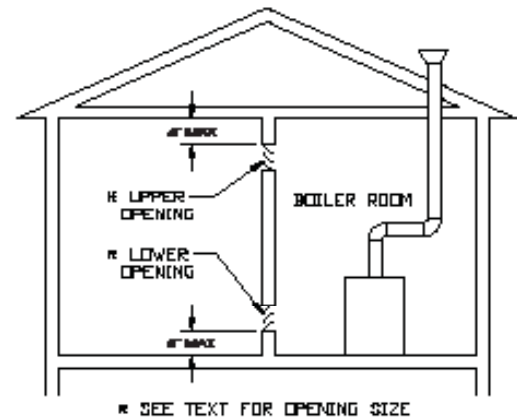


Figure 6-1: Indoor Combustion Air Method

# 7 Venting

## DANGER

### Asphyxiation Hazard.

- Failure to vent this boiler in accordance with these instructions could cause products of combustion and/or carbon monoxide to enter living space, resulting in severe personal injury, death or substantial property damage.
- Vent installation shall be in accordance with local codes, authority having jurisdiction or *National Fuel Code, ANSI Z223.1/NFPA 54* or applicable requirements of the local building codes.

Do not vent this boiler with vent systems not specifically specified in this manual. Prohibited vent system components include, but are not limited to:

- CPVC, PVC, Radel® (polyphenolsulfone) and other Non-metallic pipe.
- Metallic pipe that is not AL29-4C stainless steel.
- Do not attempt to vent this boiler into a masonry or "B" vent chimney.
- Do not use a barometric damper, draft hood or vent damper with this boiler.
- Do not attempt to mix components from different approved vent systems.
- Do not connect this boiler with any other appliances.
- Do not penetrate vent pipe with holes or fasteners.
- Do not locate vent termination under a deck.

**NOTICE:** When this boiler is direct vented, refer to this section for proper installation of the venting system. Refer to Appendix A for the proper design and assembly of the air intake system.

### 1. Vent System Design

There are two basic ways to vent this boiler:

- Horizontal ("side wall") venting using an approved AL29-4C stainless steel vent system.
- Vertical venting using an approved AL29-4C stainless steel vent system.

Table 7-1 summarizes these venting options. One of the columns in Table 7-1 must describe the planned vent system exactly. In addition, observe the following guidelines:

A. Approved Vent Systems - Use only one of the approved vent systems shown in Table 7-7. These systems are made of a special stainless steel alloy (AL29-4C) for protection against corrosive flue gas condensate. They are also designed to provide a gas tight seal at all joints and seams so that flue gas does not enter the building. Each approved vent system has unique method for installation - do not attempt to mix components from different vent systems.

### B. Maximum Vent Lengths

The maximum length of the vent piping depends upon the vent option selected, the vent pipe size, and the boiler size. See Table 7-1 for the maximum vent length.

The maximum allowable vent length must be reduced by the amount shown in Table 7-8 for each elbow used. Note: Termination fittings are not counted when counting additional elbows.

*Example:*

*A 3 in. vent system is planned for a horizontal direct vented 105,000 BTU/hr boiler which has the following components:*

*2 ft. vertical pipe  
1 90 elbow  
5 ft. horizontal pipe  
1 90 elbow  
3 ft. horizontal pipe  
1 45 elbow  
4 ft. horizontal pipe  
1 termination tee*

*The Vent Option #1 column in Table 6.1 describes a horizontal direct exhaust system using 3 in. vent pipe. From this column, we see that this boiler may have a vent length of up to 50 ft. The termination tee is not considered. From Table 6.8, the equivalent length of the 3 in. 45 elbow, is 4 ft. and the equivalent length of the 3 in. 90 degree elbow, is 5.5 ft. The maximum allowable run of straight pipe on this system is therefore:*

*50 ft. – 5.5 ft. – 5.5 ft. – 4.0 ft. = 35 ft.*

*Since the planned installation has only 14 ft. of straight pipe, the planned vent length is acceptable.*

## 7A Vent System Design *(continued)*

**Table 7-1: Summary Of Venting Options Using Indoor Combustion Air**  
(See Appendix A for Options Using Outdoor Air)

| Classification Used in this Manual |                  | Horizontal Direct Exhaust  |                        | Vertical Direct Exhaust |                        |
|------------------------------------|------------------|--|------------------------|-------------------------|------------------------|
| Vent Option #                      |                  | 1  | 2                      | 3                       | 4                      |
| Illustrated in Figure              |                  | 7-2  | 7-2                    | 7-6                     | 7-6                    |
| Structure Penetration              |                  | Wall   | Wall                   | Roof                    | Roof                   |
| Material                           |                  | Listed AL29-4C Stainless Special Gas Vent System (See Table 6.7) |                        |                         |                        |
| Nominal Diameter (inches)          |                  | 3  | 4 <sup>3</sup>         | 3                       | 4                      |
| Maximum Vent Length                | 3 thru 6 Section | 50 ft.   | Not Permitted          | 50 ft.                  | Not Permitted          |
|                                    | 7 Section        | 15 ft.   | 50 ft.                 | 15 ft.                  | 50 ft.                 |
|                                    | 8 Section        | Not Permitted  | 40 ft.                 | Not Permitted           | 40 ft.                 |
| Terminal Option A                  |                  | 3 in. Tee <sup>1</sup>   | 4 in. Tee <sup>1</sup> | 3 in. Cap <sup>1</sup>  | 4 in. Cap <sup>1</sup> |
| Terminal Option B                  |                  | Miter + 45 Elbow <sup>2</sup>                                    | Not Permitted          | Not Permitted           | Not Permitted          |

1. Tee or Cap terminal is supplied by the installer and is compatible with special gas vent system. See Table 7-7 for details.
2. Suitable for use on 3 section thru 6 section only. Miter terminal is part #8110701 and is purchased separately. 45° elbow is by special gas vent manufacturer.
3. The 7 section is factory supplied with a 3 in. adaptor. A 3 x 4 increaser compatible with the special gas vent system is required when this model is vented using 4 in. pipe. When used, this increaser must be the first fitting installed on the boiler adaptor.

**NOTICE:** Do not exceed maximum vent system length. Refer to Table 7-1 in this section for maximum vent system length. Use only vent terminals and terminal locations shown in Tables 7-1, and 7-6 and related Figures in this section.

C. Permitted Terminals for Horizontal Venting  
(Vent Option 1, 2) - Table 7-1 shows permitted types of terminals.

D. Horizontal Vent Terminal Location - Observe the following limitations on the vent terminal location (also see Figure 7-9):

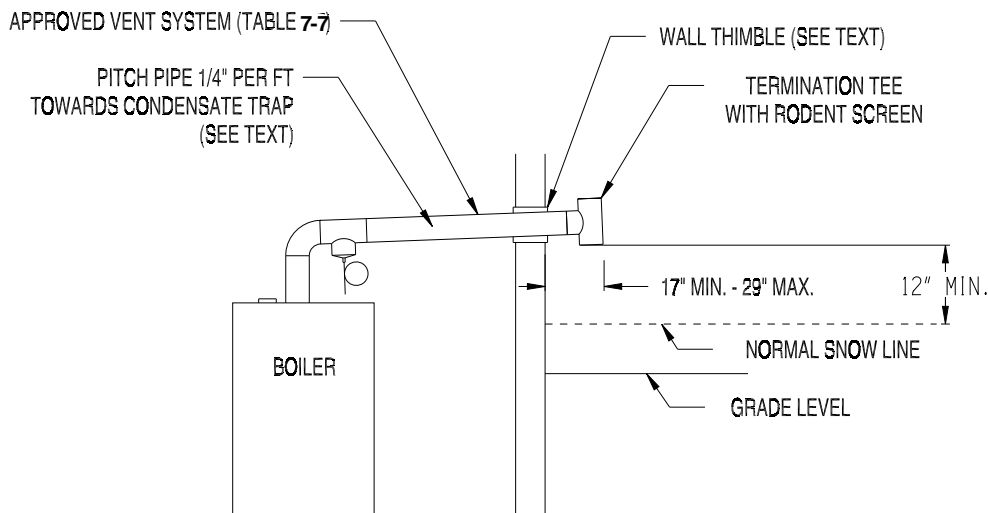
- Terminal must be at least 4 feet below or 4 feet horizontally from any operable window, door, or gravity air inlet into the building.
- The bottom of the terminal must be at least 12 in. above the normal snow line. In no case should it be less than 12 in. above grade level.
- Do not locate the vent terminal over a public walkway.
- The bottom of the terminal must be at least 3 feet above any forced air inlet located within 10 feet.
- Minimum clearance from electric meters, gas meters, regulators, and relief equipment:

United States - Minimum 4 ft. (1.22 m) horizontally from and in no case above or below, unless a 4 ft. (1.22 m) horizontal distance is maintained.

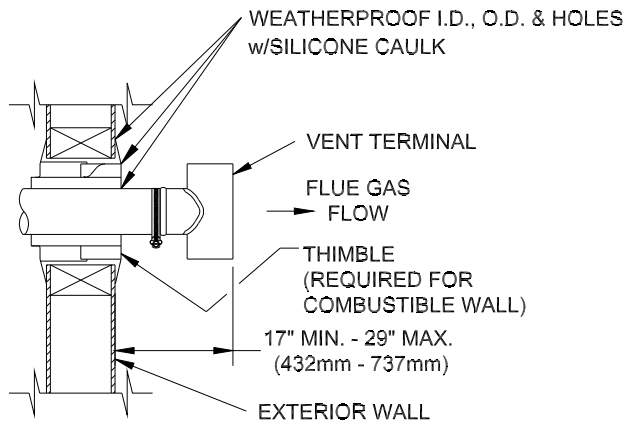
Canada - Minimum 6 ft. (1.83 m) horizontally from and in no case above or below, unless a 6 ft. (1.83 m) horizontal distance is maintained.

- Do not locate the terminal under decks or similar structures.
- In general, the top of the vent terminal must be at least 4 ft. below eaves, soffits, and other overhangs. If the overhang is unventilated and if the terminal can extend beyond the overhang while meeting the stick-out requirements shown in Figure 7-3 or 7-4, this vertical clearance can be reduced to as little as 12 in. See Figure 7-9c. Note that flue gas condensate will form under such overhangs and construction in this area must be appropriately protected.
- Terminal must be at least 12 in. from an inside corner. Exception: if window and/or air inlet is within four (4) feet of an inside corner, then vent terminal must be at least six (6) feet from adjoining wall of inside corner.
- Under certain conditions, water in the flue gas may condense on the structure in areas around the terminal. If these areas are made of materials subject to damage from flue gas condensate or ice, they should be protected.

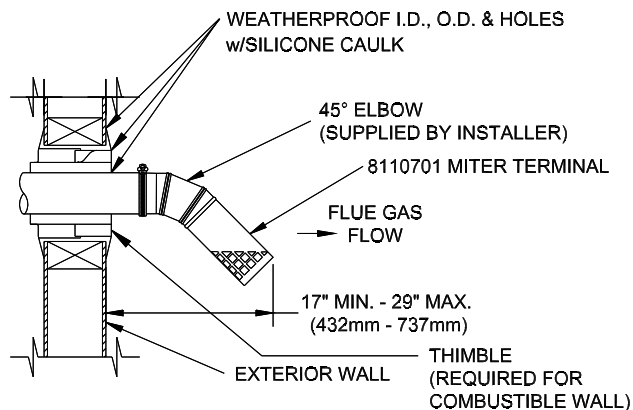
# 7A Vent System Design *(continued)*



**Figure 7-2: Horizontal Direct Exhaust Vent System (Vent Option 1, 2)**



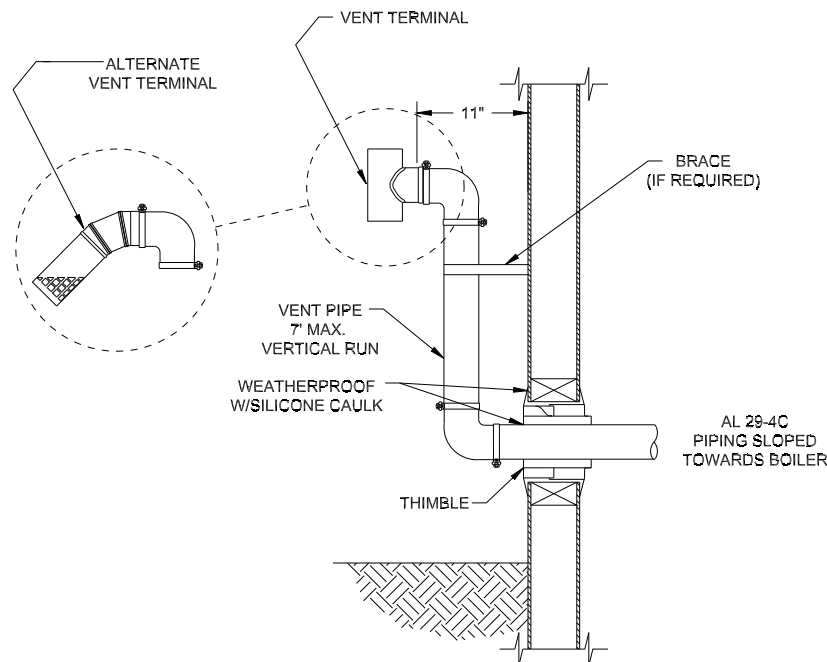
**Figure 7-3: Tee Terminal**



**Figure 7-4: Optional Miter Terminal (3 thru 6 section only)**

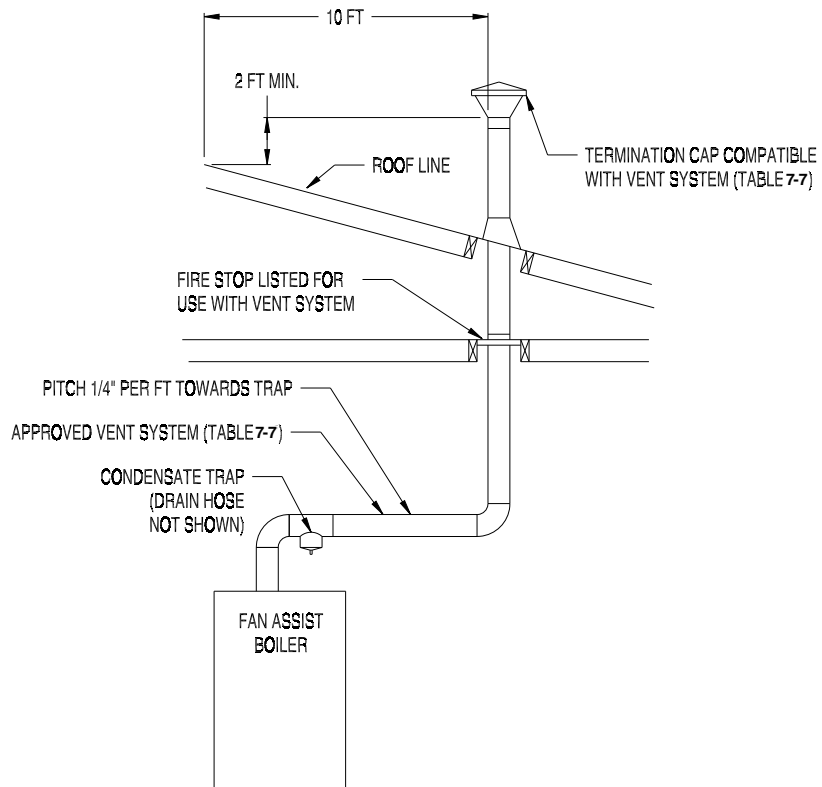
## 7A Vent System Design *(continued)*

- If possible, install the terminal on a wall away from the prevailing wind. Reliable operation of this boiler cannot be guaranteed if the terminal is subjected to winds in excess of 40 mph.
  - The noise level in the vicinity of the terminal is approximately 65 dB (roughly the level of a normal conversation). Avoid positioning the terminal in areas where this might be objectionable.
- E. Terminal Offsets - Tee terminals may be offset by as much as 7 ft. as shown in Figure 7-5. This sometimes helps maintain the 12 in. minimum clearance required above the snow line. The extra two elbows and the section of vertical pipe on the outside of the building must be counted when checking that the maximum vent pipe length is not exceeded. When this offset is used, the horizontal section of vent pipe must be pitched away from the outside so that condensate cannot collect in the lower offset elbow.
- F. Permitted Terminals for Vertical Venting (Vent Option 3, 4) - Terminals used on these systems are caps provided by the vent system manufacturer. Vent manufacturer part numbers for these caps are shown in Table 7-7.
- G. Vertical Vent Terminal Locations (Vent Option 3, 4) - The lowest discharge opening on the cap must be at least 2 feet above any object located within 10 feet. (Figure 7-6)
- H. Wall Thimbles – Wall thimbles are required where the vent pipe passes through combustible walls with less than the required clearance shown in Figure 4-2 or as required by local codes. Vent manufacturer's wall thimble part numbers are shown in Table 7-7.
- I. Condensate Traps and Pitch of Horizontal Piping – All installations require a condensate trap. Pitch all horizontal piping  $\frac{1}{4}$  in. per foot so that any condensate or rain water in the vent system will run towards this trap. Vent manufacturer's part numbers for suitable traps are shown in Table 7-7.
- J. Fire Stops and Wall Thimbles – Use fire stops where required by code or by the vent system manufacturer. Consult vent system manufacturer's literature for information on suitable fire stops.
- K. Supports - Vertical and horizontal sections of vent pipe must be properly supported. See the Vent System assembly section of this manual for more information.
- L. Access for Inspection - Refer to the vent manufacturer's instructions for access requirements to vent components.



**Figure 7-5: Optional Terminal Offset for Horizontal Vent Systems**

## 7A Vent System Design *(continued)*



**Figure 7-6: Vertical Direct Exhaust System (Vent Option 3, 4)**

## 7A Vent System Design *(continued)*

**Table 7-7: Permissible Vent Systems And Principle Vent Components**

| MANUFACTURER         | VENT SYSTEM                      | SIZE | CONDENSATE TRAP                | WALL THIMBLES               | HORIZONTAL TERMINATION | VERTICAL TERMINATION |
|----------------------|----------------------------------|------|--------------------------------|-----------------------------|------------------------|----------------------|
| HEAT FAB             | SAF-T VENT EZ SEAL               | 3    | 9321<br>(NOTE 2)               | 7393GC<br>7393GCS<br>5391CI | TEE: 7390TEE           | 5300CI               |
|                      |                                  | 4    | 9421<br>(NOTE 2)               | 7493GC<br>7493GCS<br>5491CI | TEE: 7490TEE           | 5400CI               |
| PROTECH SYSTEMS INC. | FASNSEAL                         | 3    | FSHDT3                         | FSWT3                       | TEE: FSTT3             | FSRC3                |
|                      |                                  | 4    | FSHDT4<br>OR FSCD4<br>(NOTE 3) | FSWT4                       | TEE: FSTT4             | FSRC4                |
| Z-FLEX               | SVE SERIES III<br>("Z-VENT III") | 3    | SVEDWCF03                      | 2SVSWTEF03                  | TEE: 2SVSTTF03         | 2SVSRCF03            |
|                      |                                  | 4    | SVEDWCF04                      | 2SVSWTEF04                  | TEE: 2SVSTTF04         | 2SVSRCF04            |
| METAL-FAB            | CORR/GUARD                       | 3    | CGSWDS(3 in.)                  | CGSWWPK(3 in.)              | TEE: CGSWTTM(3 in.)    | CGSWC(3 in.)         |
|                      |                                  | 4    | CGSWDS(4 in.)                  | CGSWWPK(4 in.)              | TEE: CGSWTTM(4 in.)    | CGSWC(4 in.)         |

**NOTES:**

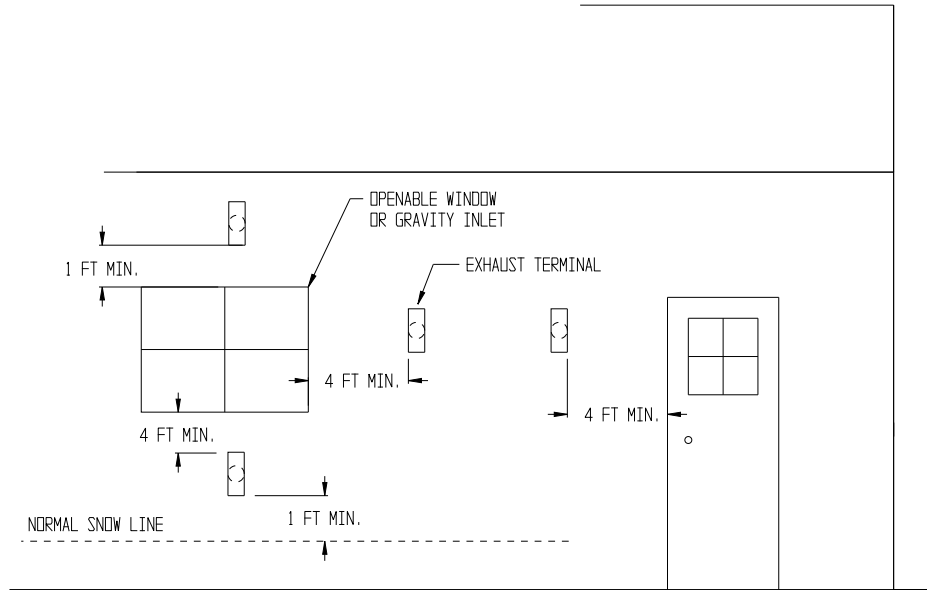
1. See vent system manufacturer's literature for other part numbers that are required such as straight pipe, elbows, firestops and vent supports.
2. All Heat Fab condensate traps shown may be installed in vertical or horizontal run.
3. Protech FSCD4 condensate trap may be installed in a vertical or horizontal run. All other Protech traps must be installed in a horizontal run only.
4. Metal-Fab CGSWDS condensate traps may only be installed in a horizontal run.
5. 8110701 Miter terminal may be used as shown in Figure 7-4. 45° elbow is supplied by vent system manufacturer.

**Table 7-8: Vent Fitting Equivalent Length**

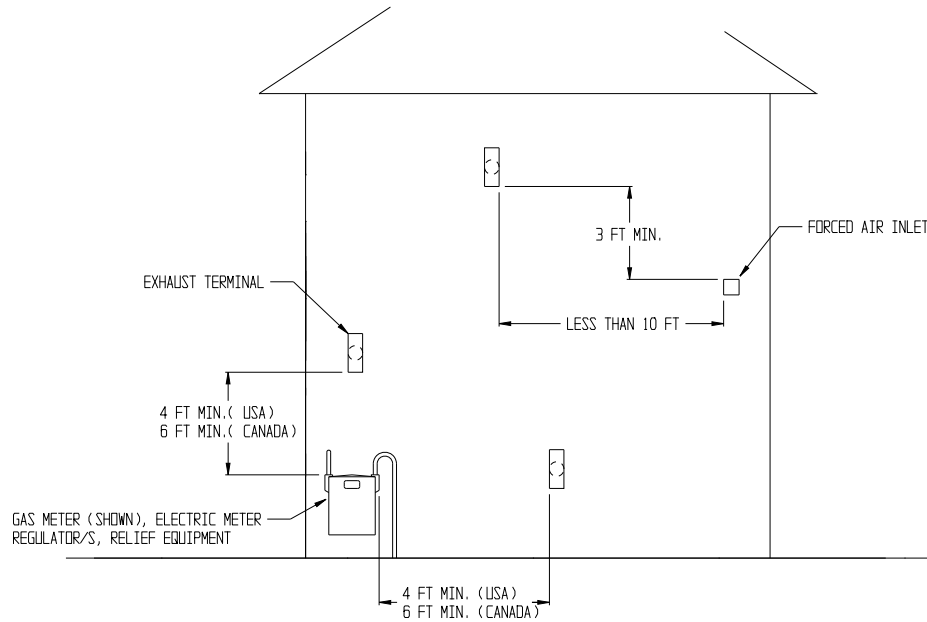
| VENT FITTING   | EQUIVALENT LENGTH (ft.)* |
|----------------|--------------------------|
| 3 in. 90 ELBOW | 5.5                      |
| 3 in. 45 ELBOW | 4.0                      |
| 4 in. 90 ELBOW | 8.0                      |
| 4 in. 45 ELBOW | 4.5                      |

\* Where different equivalent lengths are published by the vent system manufacturer, these may be used in lieu of the values shown in Table 7-8.

# 7A Vent System Design *(continued)*

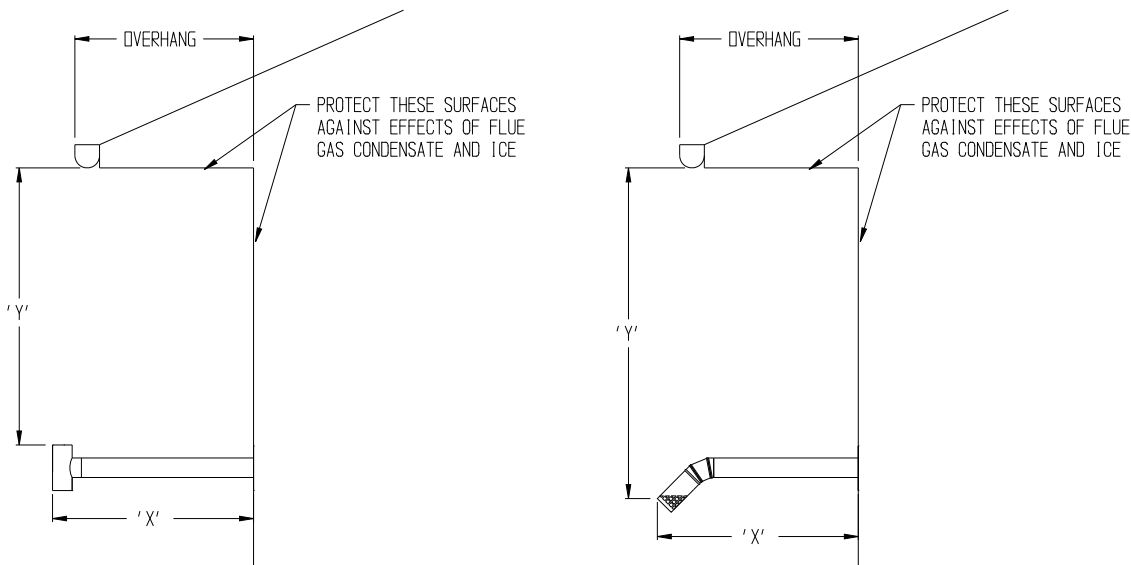


**Figure 7-9a: Location of Vent Terminal Relative to Windows, Doors and Grades**



**Figure 7-9b: Location of Vent Terminal Relative to Meters and Forced Air Inlets**

# 7A Vent System Design *(continued)*



| 'Y'                 | 'X'           | Max. Overhang |
|---------------------|---------------|---------------|
| 0 - 12 in.          | NOT PERMITTED |               |
| 12 - 48 in.         | 17 - 29 in.   | X minus 7 in. |
| Greater than 48 in. | 17 - 29 in.   | 36 in.        |

**Note:** Overhang may not be ventilated if 'Y' is less than 48 in.

**Figure 7-9c: Location of Vent Terminal Under Overhangs**

## 7B Removing Boiler From Common Chimney

### 2. Removing Boiler From Common Chimney

When an existing boiler is removed from a common venting system, the common venting system is likely to be too large for proper venting of the appliances remaining connected to it.

At the time of removal of an existing boiler, the following steps shall be followed with each appliance remaining connected to the common venting system placed in operation, while the other appliances remaining connected to the common venting system are not in operation:

- A. Seal any unused openings in the common venting system.
- B. Visually inspect the venting system for proper size and horizontal pitch and determine there is no blockage or restriction, leakage, corrosion, and other deficiencies which could cause an unsafe condition.
- C. Insofar as is practical, close all building doors and windows and all doors between the space in which the appliances remaining connected to the common venting system are located and other spaces of the building. Turn on clothes dryers and any appliance not connected to the common venting system. Turn on any exhaust fans, such as range hoods and bathroom exhausts, so they will operate at maximum speed. Do not operate a summer exhaust fan. Close fireplace dampers.
- D. Place in operation the appliance being inspected. Follow the Lighting (or Operating) Instructions. Adjust thermostat so appliance will operate continuously.
- E. Test for spillage at the draft hood relief opening after 5 minutes of main burner operation. Use the flame of a match or candle, or smoke from a cigarette, cigar or pipe.
- F. After it has been determined that each appliance remaining connected to the common venting system properly vents when tested as outlined above, return doors, windows, exhaust fans, fireplace dampers and any other gas-burning appliance to their previous condition of use.
- G. Any improper operation of the common venting system should be corrected so the installation conforms with the *National Fuel Gas Code, ANSI Z223.1/NFPA 54*. When resizing any portion of the common venting system, the common venting system should be resized to approach the minimum size as determined using the appropriate tables in Chapter 13 of the *National Fuel Gas Code, ANSI Z223.1/NFPA 54* and/or the *Natural Gas and Propane Installation Code, CAN/CSA B149.1*.

### WARNING

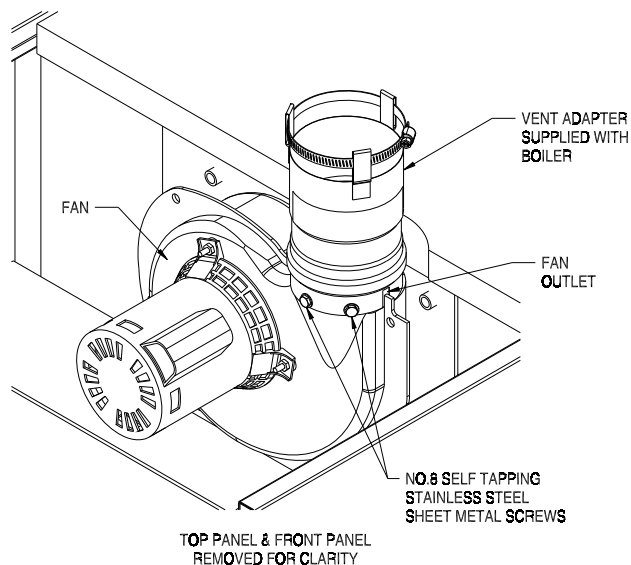
Never common vent this boiler with other appliances.

Au moment du retrait d'une chaudière existante, les mesures suivantes doivent être prises pour chaque appareil toujours raccordé au système d'évacuation commun et qui fonctionne alors que d'autres appareils toujours raccordés au système d'évacuation ne fonctionnent pas:

- A. Sceller toutes les ouvertures non utilisées du système d'évacuation.
- B. Inspecter de façon visuelle le système d'évacuation pour déterminer la grosseur et l'inclinaison horizontale qui conviennent et s'assurer que le système est exempt d'obstruction, d'étranglement, de fuite, de corrosion et autres défaillances qui pourraient présenter des risques.
- C. Dans la mesure du possible, fermer toutes les portes et les fenêtres du bâtiment et toutes les portes entre l'espace où les appareils toujours raccordés au système d'évacuation sont installés et les autres espaces du bâtiment. Mettre en marche les sècheuses, tous les appareils non raccordés au système d'évacuation commun et tous les ventilateurs d'extraction comme les hottes de cuisinière et les ventilateurs des salles de bain. S'assurer que ces ventilateurs fonctionnent à la vitesse maximale. Ne pas faire fonctionner les ventilateurs d'été. Fermer les registres des cheminées.
- D. Mettre l'appareil inspecté en marche. Suivre les instructions d'allumage. Régler le thermostat de façon que l'appareil fonctionne de façon continue.
- E. Faire fonctionner le brûleur principal pendant 5 min ensuite, déterminer si le coupe-tirage déborde à l'ouverture de décharge. Utiliser la flamme d'une allumette ou d'une chandelle ou la fumée d'une cigarette, d'un cigare ou d'une pipe.
- F. Une fois qu'il a été déterminé, selon la méthode indiquée ci-dessus, que chaque appareil raccordé au système d'évacuation est mis à l'air libre de façon adéquate. Remettre les portes et les fenêtres, les ventilateurs, les registres de cheminées et les appareils au gaz à leur position originale.

## 7B Removing Boiler From Common Chimney *(continued)*

- G. Tout mauvais fonctionnement du système d'évacuation commun devrait être corrigé de façon que l'installation soit conforme au National Fuel Gas Code, ANSI Z223.1/NFPA 54 et (ou) aux codes d'installation CAN/CSA-B149.1. Si la grosseur d'une section du système d'évacuation doit être modifiée, le système devrait être modifié pour respecter les valeurs minimales des tableaux pertinents de l'appendice F du National Fuel Gas Code, ANSI Z223.1/NFPA 54 et (ou) des codes d'installation CAN/CSA-B149.1.



**Figure 7-10: Installation of Vent Adapter**

### 3. Vent System Assembly

#### A. General Assembly Notes:

- i. Where the use of "silicone" is called for in the following instructions, use GE RTV 106 for the vent adapter.
- ii. Longitudinal welded seams should not be placed at the bottom of horizontal sections of exhaust pipe.
- iii. Do not drill holes in vent pipe.
- iv. Do not attempt to mix vent components of different vent system manufacturers.
- v. In some cases, there are differences between the vent system installation instructions in this manual and those in the vent system manufacturer's manual. Where such differences exist, this manual takes precedence over the vent system manufacturer's manual.

#### **CAUTION**

Approved vent systems rely on gaskets for proper sealing. Take the following precautions:

- Make sure that gasket is in position and undamaged in the female end of the pipe.
- Make sure that both the male and female pipes are free of damage prior to assembly.
- After making the vent adapter connection, only cut vent pipe as permitted by the vent manufacturer in accordance with their instructions. When pipe is cut, cut end must be square and carefully deburred prior to assembly.

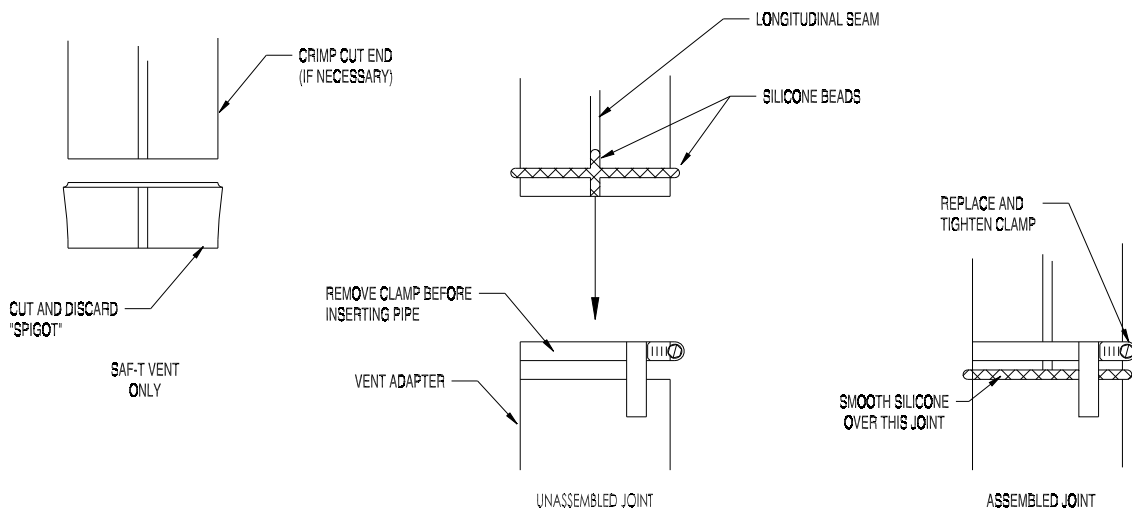
- B. Vent Adapter Installation – The vent adapter is shipped loose. Mount the vent adapter to the fan outlet on the boiler as shown in Figure 7-10 using the two stainless steel screws provided.

#### C. Connection of Vent Pipe to Vent Adapter

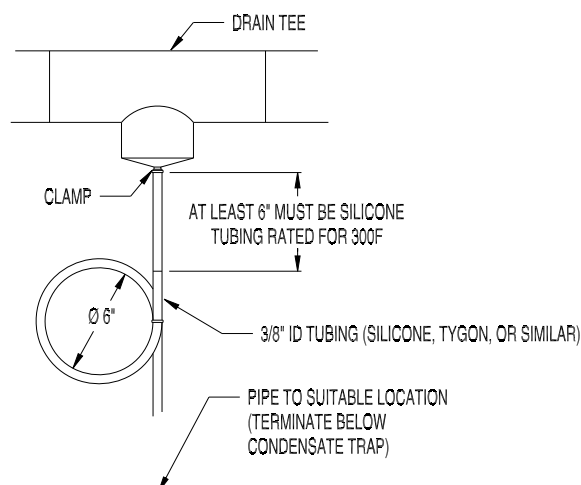
- i. If using Heat Fab Saf-T-Vent, cut the spigot off of the first piece of pipe using a sharp pair of aviation snips, an abrasive cut-off, or a plasma cutter. The male end of the pipe made by other vent system manufacturers should slip into the vent adapter without modification.
- ii. Remove the hose clamp shipped on the vent adapter. Bend the three hose clamp tabs on this adapter outward slightly.
- iii. Clean the exterior of the male end of the first piece of pipe and the inside of the vent adapter on the boiler with an alcohol pad.

## 7C Vent System Assembly *(continued)*

- iv. On the male end of the pipe, apply a ¼ in. wide bead of high temperature silicone approximately ½ inch from the male end of the pipe. Also apply a ¼ in. bead of silicone along the first 2 ½ in. of the longitudinal weld as shown in Figure 7-11.
  - v. Insert the male end of the pipe into the boiler vent adapter until it bottoms out.
  - vi. Apply an additional bead of silicone over the outside of the joint and smooth out (Fig 7-11). Also apply silicone over the seams in the vent adapter.
  - vii. Replace and tighten the clamp on the vent adapter.
- D. Complete the rest of the vent system in accordance with the vent manufacturer's instructions.
  - E. Condensate Traps:
    - i. Trap must have the basic configuration shown in Figure 7-12. All tubing is 3/8 I.D.
    - ii. All drain tubing must be acid resistant.
    - iii. At least the first 6 inches of tubing must be silicone with a 300°F temperature rating.
    - iv. Pipe condensate to a drain or other suitable location. Make sure that condensate disposal method is in accordance with local regulations. Ensure condensate is not subjected to freezing temperatures.



**Figure 7-11: Connection of First Vent Pipe to Boiler Vent Adapter**



**Figure 7-12: Condensate Trap/Drain Detail**

## 8 Water Piping

### ⚠ WARNING

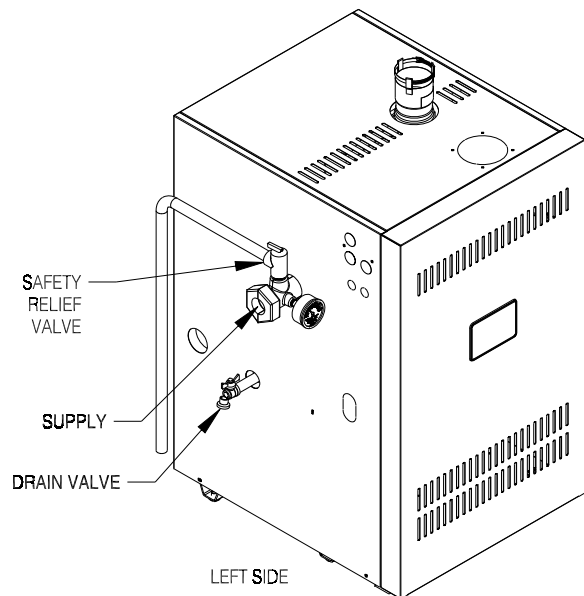
- Failure to properly pipe boiler may result in improper operation and damage to boiler or building.
- Install boiler so that the gas ignition system components are protected from water (dripping, spraying, rain, etc.) During appliance operation and service (circulator replacement, etc.).
- Operation of this boiler with continuous return temperatures below 120°F can cause severe heat exchanger corrosion damage.
- Operation of this boiler in a system having significant amounts of dissolved oxygen can cause severe heat exchanger corrosion damage.
- Do not use toxic additives, such as automotive antifreeze, in a hydronic system.

### ⚠ DANGER

- Pipe relief valve discharge to a safe location. The safety relief valve may discharge scalding hot water.
- Do not install any other valves in the safety relief valve discharge line.
- Do not move relief valve from factory specified location.
- Do not plug relief valve discharge. Blocking the safety relief valve may result in boiler explosion.
- Do not install a relief valve with a setting greater than 50 psi.

### ⚠ WARNING

- Pipe discharge of relief valve to a location where water will not create a hazard or cause property damage if the relief valve opens.
- End of discharge pipe must terminate in an unthreaded pipe.
- Relief valve must terminate no greater than 6 inches above floor.
- Termination of the relief valve discharge piping must be in an area where it is not likely to become plugged by debris or subjected to freezing.
- Union may be installed in safety relief valve piping.



**Figure 8-1: Standard Safety Relief Valve Position**  
1. Standard Piping

Figure 8-2 shows typical boiler system connections on a single zone system. Additional information on hydronic system design may be found in the I=B=R Guide RHH published by Air Conditioning Contractors of America (ACCA). The components in this system and their purposes are as follows:

- A. Safety Relief Valve (Required) - Mount the relief valve on the left side of the boiler as shown in Figure 8-1 using the 1-1/4 supply water manifold provided with the boiler. The relief valve shipped with the boiler is set to open at 30 psi. This valve may be replaced with one having a pressure up to the "Maximum Allowable Working Pressure" shown on the rating plate. If the valve is replaced, the replacement must have a relief capacity in excess of the minimum relief valve capacity for the boiler.

Pipe the discharge of the relief valve to a location where water or steam will not create a hazard or cause property damage if the valve opens. The end of the discharge pipe must terminate in an unthreaded pipe. If the relief valve discharge is not piped to a drain it must terminate at least 6 inches above the floor. Do not run relief valve discharge piping through an area that is prone to freezing. The termination of the relief valve discharge piping must be in an area where it is not likely to become plugged by debris.

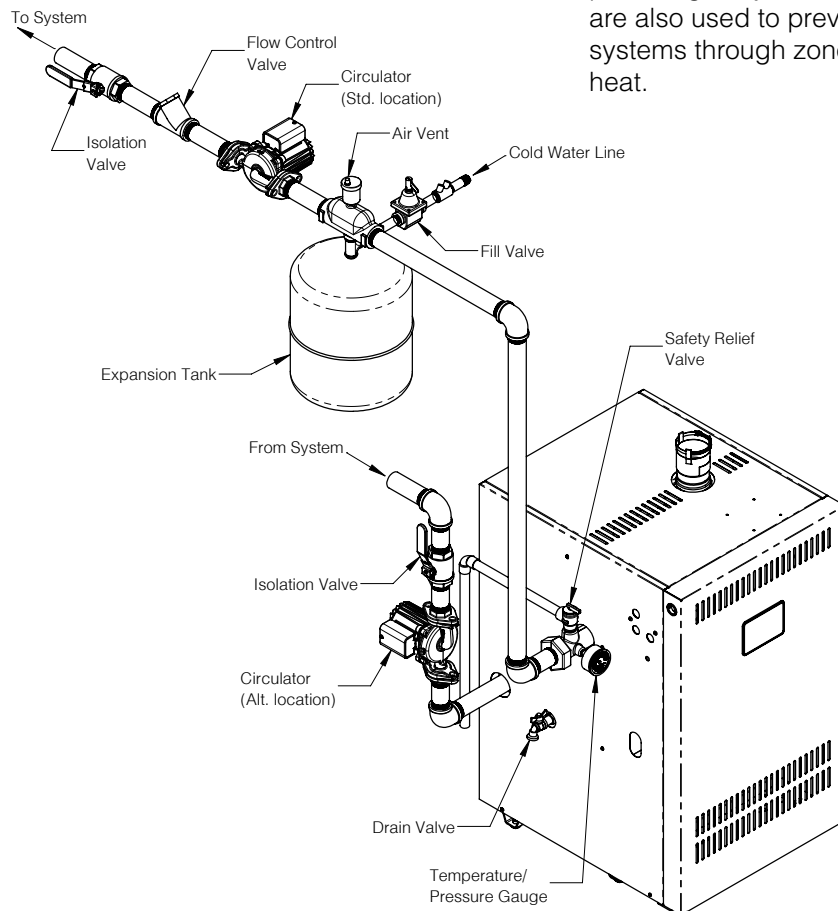
- B. Circulator (Required) - The circulator is shipped loose with the boiler. If the circulator is mounted in the supply it should be positioned just downstream of the expansion tank as shown in Figure 8-2.

## 8 Water Piping *(continued)*

- C. Expansion Tank (Required) - If this boiler is replacing an existing boiler with no other changes in the system, the old expansion tank can generally be reused. If the expansion tank must be replaced, consult the expansion tank manufacturer's literature for proper sizing.
- D. Fill Valve (Required) - Either a manual or automatic fill valve may be used. The ideal location for the fill is at the expansion tank.
- E. Automatic Air Vent (Required) - At least one automatic air vent is required. Manual vents will usually be required in other parts of the system to remove air during initial fill.
- F. Low Water Cut-Off (factory supplied) This boiler is equipped with a low water cut-off (LWCO) that prevents the boiler from firing if there is inadequate water in the boiler. This LWCO is an automatic reset type, meaning that it will allow the boiler to restart automatically if the low water condition is corrected. This LWCO satisfies the requirements of most installation codes used for residential installations, however some jurisdictions may require a manual reset low water cut-off which requires a reset button to be pushed to restart the boiler.

If a manual reset LWCO is required, it must be installed in the supply piping just above the boiler in accordance with the LWCO manufacturer's instructions (the factory supplied LWCO is left in place). No intervening valves may be installed between an externally piped LWCO and the boiler. Wire an external manual reset LWCO to either break 120 VAC power to the boiler, or break the external limit connection shown in Section 9.

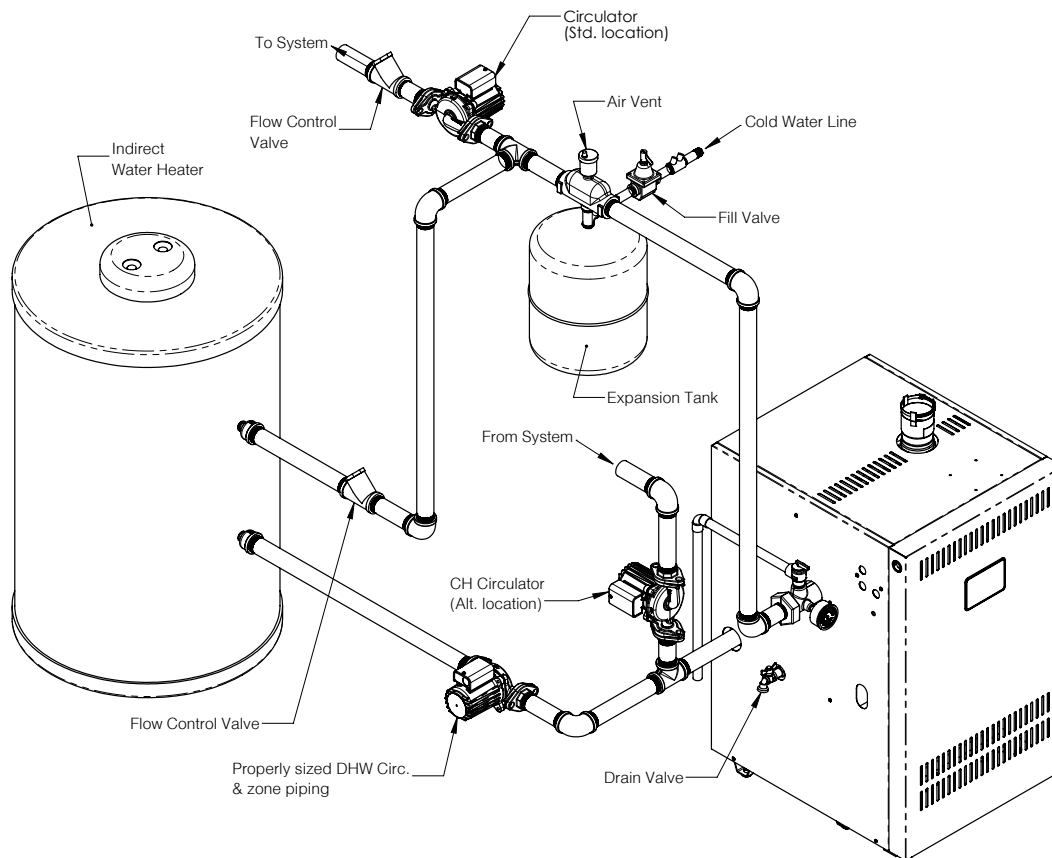
- G. Manual Reset High Limit (Required by some codes) - This control is required by ASME CSD-1 and some other codes. Install the high limit in the boiler supply piping just beyond the boiler with no intervening valves. Set the manual reset high limit as far above the operating limit setting as possible, but not over 240°F. Wire the control to break the 120 VAC electrical supply to the boiler or the external limit connection shown in Section 9.
- H. Flow Control Valve (Required under some conditions) - The flow control valve prevents flow through the system unless the circulator is operating. A flow control valve may be necessary on converted gravity systems to prevent gravity circulation. Flow control valves are also used to prevent flow in circulator zone systems through zones that are not calling for heat.



**Figure 8-2: Standard Boiler Piping**

## 8 Water Piping *(continued)*

- I. Isolation Valves (Optional) - Isolation valves are useful if the boiler must be drained, as they will eliminate having to drain and refill the entire system.
- J. Drain Valve - The drain valve is shipped in the boiler parts bag. Install it in the 3/4 in. tapping as shown in Figure 8-1.
2. Piping For Special Situations Certain types of heating systems have additional requirements. Some of the more common variations follow:
- A. Indirect Water Heaters - Figure 8-3 shows typical indirect water heater piping. Boiler piping is the same as for any two-zone system. Figure 8-3 shows circulator zoning, which is usually preferred for indirect water heaters. Size the circulator and indirect water heater piping to obtain the boiler water flow through the indirect water heater called for by the indirect water heater manufacturer.
- B. Large Water Volume and Low Temperature Systems - Use a system bypass if boiler is to be operated in a system which has a large volume or excessive radiation where low boiler water temperatures may be encountered (i.e. converted gravity circulation system, etc.). (See Appendix C "Low Return Water Temperatures").
- C. Systems Containing Oxygen - Many hydronic systems contain enough dissolved oxygen to cause severe corrosion damage to a cast iron boiler such as this one. Some examples include:
- Radiant systems that employ tubing without an oxygen barrier.
  - Systems with routine additions of fresh water.
  - Systems which are open to the atmosphere.



**Figure 8-3: Indirect Water Heater Boiler Side Piping**

## 8 Water Piping *(continued)*

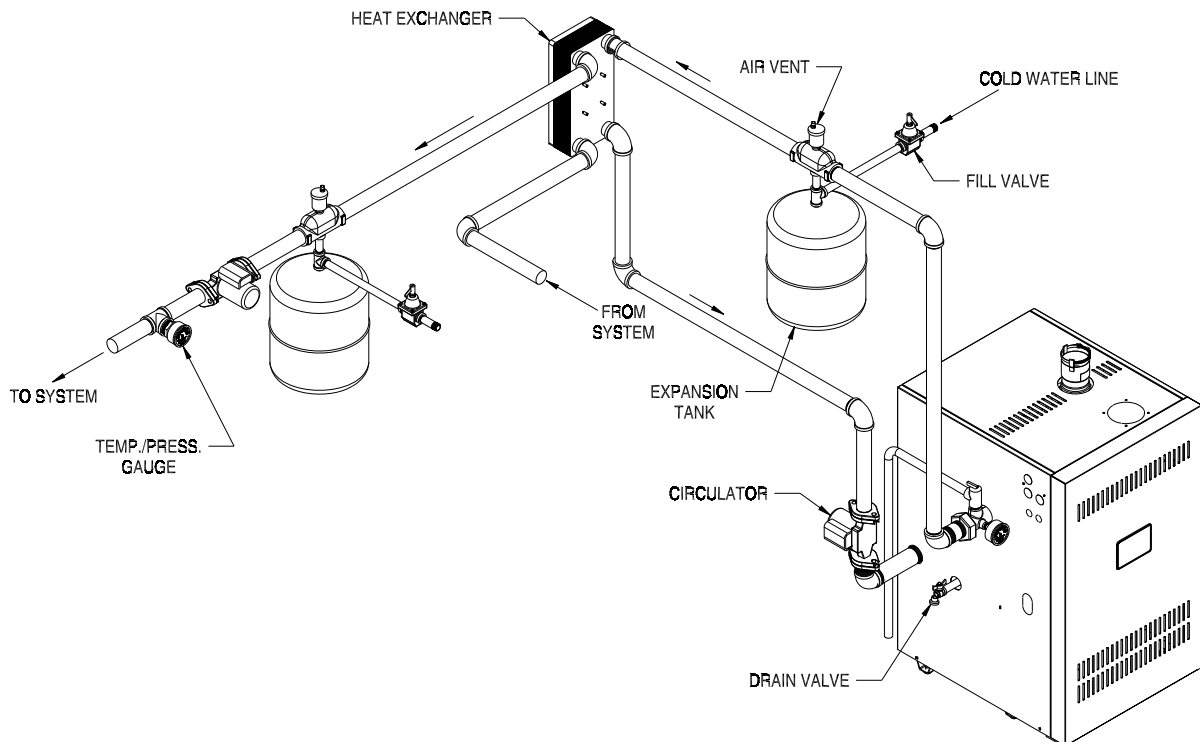
If the boiler is to be used in such a system, it must be separated from the oxygenated water being heated with a heat exchanger as shown in Figure 8-4.

Consult the heat exchanger manufacturer for proper heat exchanger sizing as well as flow and temperature requirements. All components on the oxygenated side of the heat exchanger, such as the circulator and expansion tank, must be designed for use in oxygenated water.

- D. Piping with a Chiller - If the boiler is used in conjunction with a chiller, pipe the boiler and chiller in parallel. Use isolation valves to prevent chilled water from entering the boiler.
- E. Air Handlers - Where the boiler is connected to air handlers through which refrigerated air passes, use flow control valves in the boiler piping or other automatic means to prevent gravity circulation during the cooling cycle.

### **⚠ WARNING**

Oxygen contamination of boiler water will cause corrosion of iron and steel boiler components and can lead to boiler failure. Warranty does not cover problems caused by oxygen contamination of boiler water or scale (lime) build-up caused by frequent addition of water.

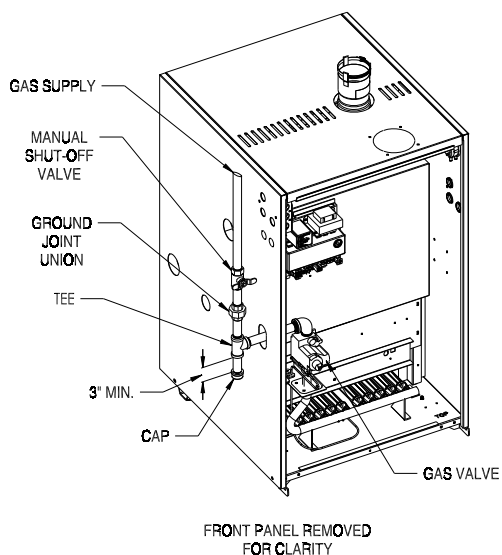


**Figure 8-4: Isolation Of Boiler From System With A Heat Exchanger**

## 9 Gas Piping

### ⚠ WARNING

- Shut off gas supply before servicing the boiler.
  - All gas piping must be gas tight. Use thread compound that is listed for gas service on all threaded joints to avoid leaks, which may result in fire or explosion.
  - Size gas piping, regulators, valves and meters so as to provide an adequate gas flow and pressure to the boiler during operation. Failure to do so may cause poor combustion, noise, injury or death.
1. Size gas piping - Design system to provide adequate gas supply to boiler. Consider these factors:
    - A. Allowable pressure drop from point of delivery to boiler. Maximum allowable system pressure is ½ psig. Actual point of delivery pressure may be less; contact gas supplier for additional information. Minimum gas valve inlet pressure is listed on rating label.
    - B. Maximum gas demand. Consider existing and expected future gas utilization equipment (i.e. water heater, cooking equipment).
  2. Connect boiler gas valve to gas supply system -
    - A. Use methods and materials in accordance with local plumbing codes and requirements of gas supplier. In absence of such requirements, follow *National Fuel Gas Code, ANSI Z223.1/NFPA 54*.
    - B. Use thread compounds (pipe dope) resistant to action of liquefied petroleum gas.
    - C. Install sediment trap, ground-joint union and manual shut-off valve upstream of boiler gas control valve. See Figure 9-1.



**Figure 9-1: Gas Connection To Boiler**

D. All above ground gas piping upstream from manual shut-off valve must be electrically continuous and bonded to a grounding electrode. Do not use gas piping as grounding electrode. Refer to *National Electrical Code, NFPA 70*.

3. Pressure test - Boiler and its gas connection must be leak tested before placing boiler in operation.
  - A. Protect boiler gas control valve. For all testing over ½ psig, boiler and its individual shutoff valve must be disconnected from gas supply piping. For testing at ½ psig or less, isolate boiler from gas supply piping by closing boiler's individual manual shutoff valve.
  - B. Locate and address leaks using listed combustible gas detector, a non corrosive leak detection fluid or other listed leak detection method. Do not use matches, candles, open flames, or other ignition source.

### ⚠ WARNING

#### Explosion Hazard.

- Failure to properly pipe gas supply to boiler could cause improper operation if leaks of flammable gas resulting in severe personal injury, death, or substantial property damage.
- Gas supply to boiler and system must be shut off prior to installing or servicing boiler gas piping.

### ⚠ DANGER

#### Explosion Hazard.

- Do not use matches, candles, open flames, or other ignition sources to check for leaks. Failure to comply could result in severe personal injury, death, or substantial property damage.

### ⚠ WARNING

- If gas pressure in the building is above ½ psig (3.5 kPa), an additional gas pressure regulator is required. Using one additional regulator for multiple gas appliances may result in unsafe boiler operation. The additional regulator must be able to properly regulate gas pressure at the input of the smallest appliance. If the regulator can not do this, two or more additional regulators are required. Consult regulator manufacturer and/or local gas supplier for instructions and equipment ratings.
- If an additional regulator is used to reduce boiler inlet pressure below 1/2 psig (3.5 kPa) it must be at least 6 to 10 ft. upstream of the boiler.
- It is very important that the gas line is properly purged by the gas supplier or utility company.

# 10 Electrical

## WARNING

- All wiring and grounding must be done in accordance with the authority having jurisdiction or, in the absence of such requirements, with the *National Electrical Code (NFPA 70)*. In Canada, all wiring and grounding must be done in accordance with the Canadian Electrical Code, Part 1 (CSA C22.1 - latest edition).
- Electrical power may be supplied from more than one circuit. Disconnect electrical power to the boiler and heating system before servicing. Positively assure that no voltage is present. Lock electrical boxes to prevent someone from inadvertently restoring power before the heating system is safe to operate.
- Never defeat or jump out safety devices.
- Protect each boiler circuit with a properly sized over-current protection device.
- Make electrical connections carefully according to the boiler's wiring diagram and instructions. Failure to properly wire electrical connections to the boiler may result in serious physical harm or property damage.
- Wire additional field supplied safety limits, such as low water cut-offs and temperature limit devices, so as to break the 120V power supply to the boiler. Do not alter the boiler's factory wiring when adding a field supplied limit device.

**NOTICE:** This boiler is equipped with a listed high water temperature limit function. This limit provides boiler shutdown in the event the boiler water temperature exceeds the set point of the limit control. Certain Local Codes require an additional water temperature limit. If necessary, install an additional water temperature limit (P/N 106056-01) or equivalent Honeywell L4006 Aquastat so as to break the 120V power supply to the boiler. Do not alter the boiler's factory wiring when adding a field supplied limit device.

1. Line Voltage (120 VAC) Field Connections – See Figure 10.1 for line voltage connections. Provide a dedicated circuit for the boiler of 15A or greater. A service switch is recommended and is required by many local codes. Locate this switch in accordance with local codes or, in the absence of any, in a location where it can be safely accessed in an emergency involving the boiler. All 120 VAC connections to the boiler itself are made inside the junction box in the boiler vestibule. 120 VAC connections are:

- Ground
- 120 VAC Hot (Black)
- 120 VAC Neutral (White)
- System Circulator Hot (Yellow)
- System Circulator Neutral (White)

The use of the Circulator outputs are as follows:

- A. System Circulator - Pumps water upon a call for heat (CH) from a heating thermostat connected to the leads shown in Figure 10-2 or from an EnviraCom thermostat.
- B. DHW Circulator - Pumps boiler water to an indirect water heater upon a call for domestic hot water (DHW) from the DHW thermostat terminals shown in Figure 10-2. This output can also be used for a second space heating zone (See Section 12 for additional information).

Maximum circulator current draw is 5.0 FLA.

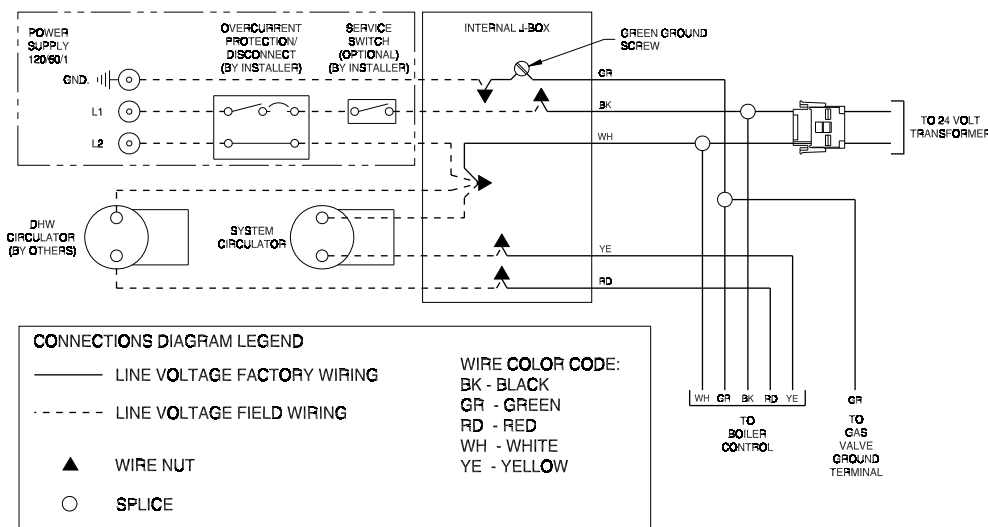
2. Low Voltage Connections – Low voltage field connections are located as shown in Figure 10-2 and are as follows:
  - A. Heating (CH) Thermostat - Connect to a 24 volt thermostat or other “dry contacts” (such as a zone panel end switch) that close upon a call for heat. Follow thermostat manufacturer's instructions. To insure proper thermostat operation, avoid installation in areas of poor air circulation, hot spots (near any heat source or in direct sunlight), cold spots (outside walls, walls adjacent to unheated areas, locations subject to drafts). Provide Class II circuit between thermostat (or zone controls) and boiler.
  - B. DHW Thermostat - If used, connect to a 24 VAC domestic hot water thermostat or 2nd space heating thermostat.
  - C. Auxiliary Limit Jumper - Used to connect auxiliary limit device. If no such devices are installed, the factory supplied jumper shown in Figures 10-2 and 10-3 must be installed for boiler to operate.

# 10 Electrical *(continued)*

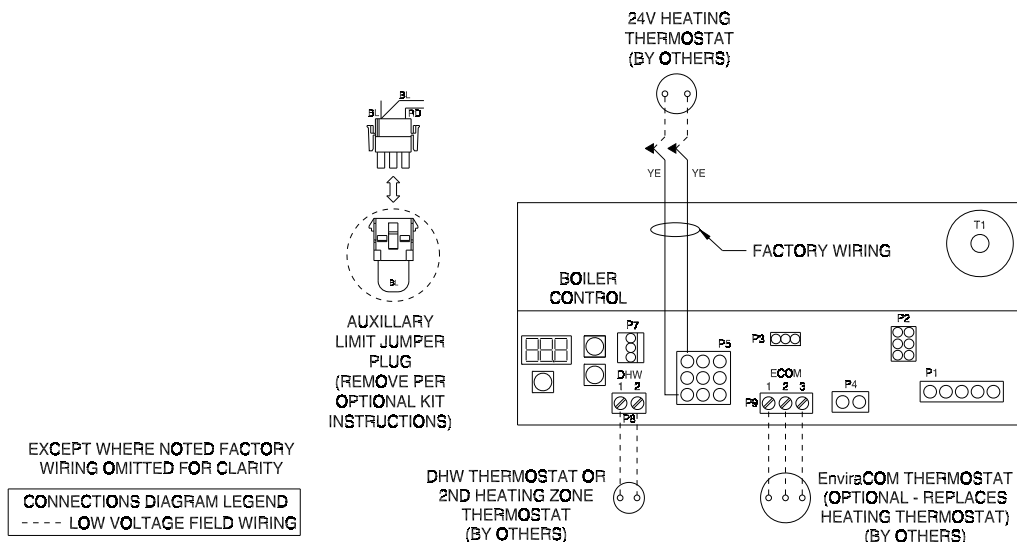
D. EnviraCOM - Used to connect an EnviraCom thermostat or other approved EnviraCom device to this boiler.

**NOTICE:**

- When making low voltage connections, make sure that no external power source is present in the thermostat circuits. If such a power source is present, it could destroy the boiler's control. One example of an external power source that could be inadvertently connected to the low voltage connections is a transformer in old thermostat wiring.
- Do not attempt to use EnviraCom connections for any purpose not explicitly permitted by the factory. Attempting to do so may result in unreliable operation and/or damage to controls.
- Do not use the transformer provided on the boiler to power external devices such as zone valves. Doing so may cause damage to the transformer.



**Figure 10-1: Line Voltage Connections**



**Figure 10-2: Low Voltage Connections**



# 10 Electrical (continued)

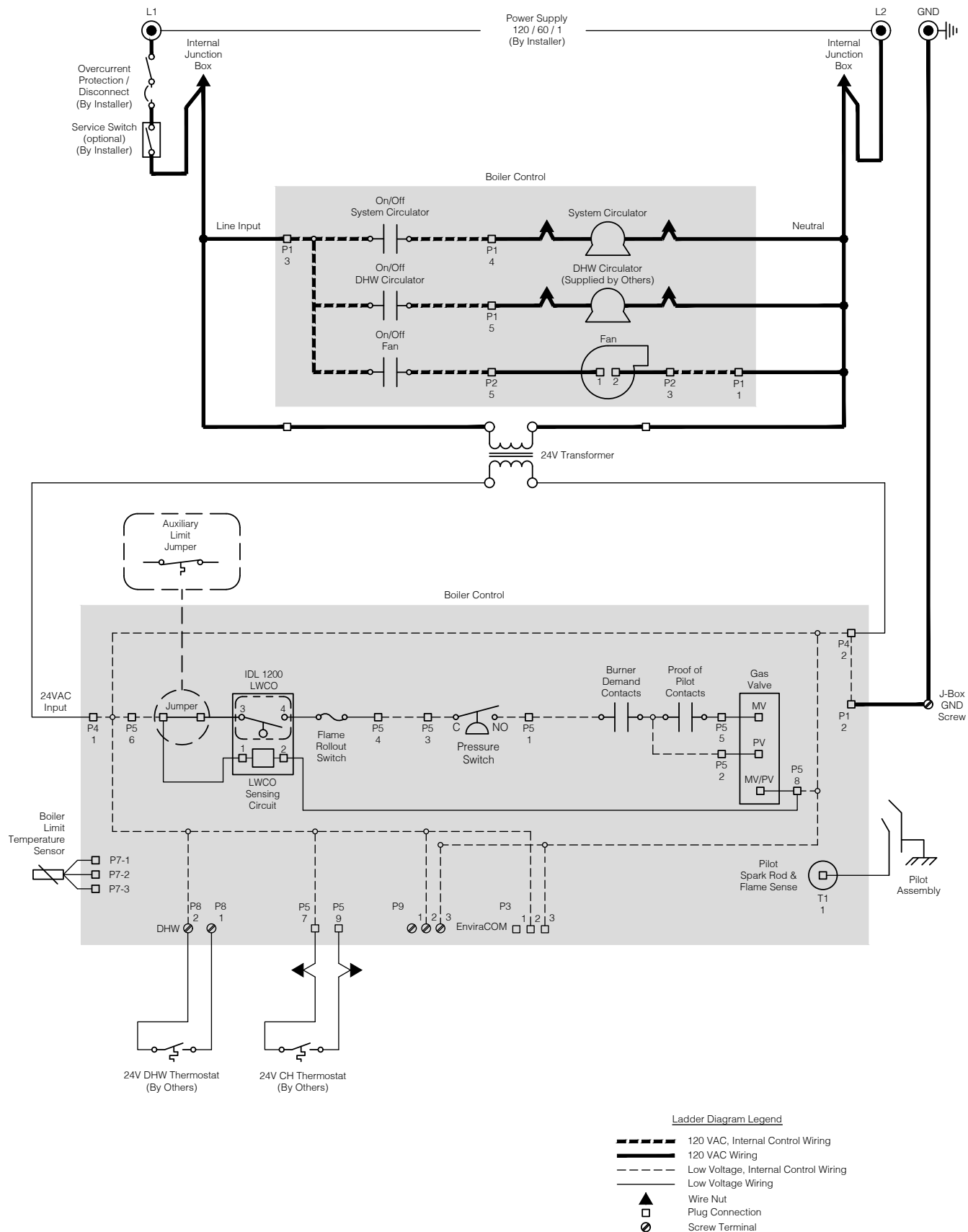


Figure 10-4: Wiring Ladder Diagram

# 11 Start-up and Checkout

## **⚠ DANGER**

### **Explosion Hazard.**

Do not use matches, candles, open flames, or other ignition sources to check for leaks. Failure to comply could result in severe personal injury, death, or substantial property damage.

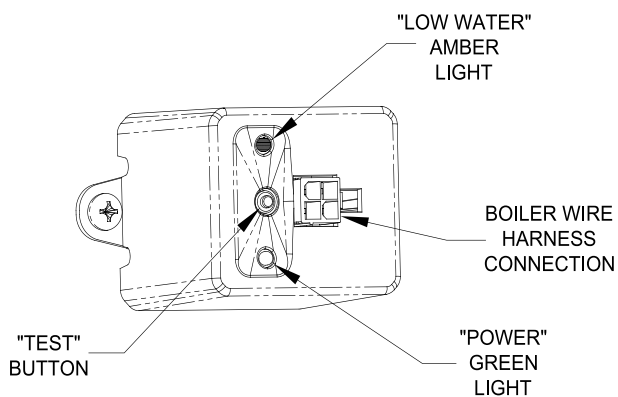
## **⚠ WARNING**

Make sure that the area around the boiler is clear and free from combustible materials, gasoline, and other flammable vapors and liquids.

1. The Installer must verify that at least one carbon monoxide alarm has been installed within a residential living space or home following the alarm manufacturer's instructions and applicable local codes before putting the appliance into operation.
2. Start with the boiler dry and the gas supply to the boiler shut off.
3. Main Burner Check - Check main burners to see that they were not dislodged during shipment. Rear of burners should be in the vertical slots in the rear of burner tray and the front of the burners should be seated completely on the orifices.
4. LWCO Probe Check - Turn on power to the boiler. Both the green power light and the yellow low water light should come on (Figure 11-1).

## **⚠ WARNING**

If the yellow light on the LWCO is not illuminated when the boiler is powered and there is no water in the boiler, shut down power to the boiler and contact the factory for assistance before proceeding further.

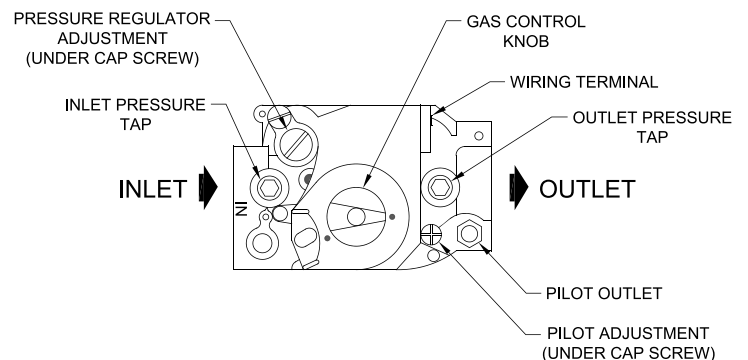


**Figure 11-1: IDL 1200 Low Water Cut-Off**

## **⚠ WARNING**

Failure to follow the following procedure exactly could result in over firing of boiler and a carbon monoxide hazard.

5. Fill the boiler and system with water and purge the system of as much air as possible.
6. Turn on the gas supply to the boiler. Check the gas line for leaks and purge piping sections that are full of air. Refer to the *National Fuel Gas Code*, the *Natural Gas and Propane Installation Code*, the gas supplier, or the authority having jurisdiction for additional information on testing and purging gas lines.



**Figure 11-2: Top View of Gas Valve**

7. Verify that the vent system is complete and free of obstructions before attempting to fire boiler. Make sure that the silicone cure time called for in the vent assembly instructions has passed before firing boiler.
8. Inspect all wiring for loose or uninsulated connections.
9. Adjust thermostat to the highest setting.

## **⚠ WARNING**

### **Explosion Hazard.**

Ensure inlet pressure tapping is fully closed after checking pressure. Failure to comply could result in severe personal injury, death, or substantial property damage.

10. Start the boiler using the operating instructions shown in Figure 11-3. Upon initial start-up, the gas train will be filled with air. Even if the gas line has been completely purged of air, it may take several tries for ignition before a flame is established. Once a flame has been established for the first time, subsequent calls for burner operation should result in a flame on the first try.

## 11 Start-up and Checkout *(continued)*

11. Check entire gas train for leaks using a listed combustible gas detector, a non corrosive leak detection fluid or other listed leak detection method while boiler is firing. Fix any leaks found immediately.
12. Check the manifold pressure and adjust if necessary. To do this, use the following procedure:
  - A. Connect a manometer to the inlet pressure tap on the gas valve (see Figure 11-2).
  - B. Check the inlet line pressure with all gas appliances on and off. The inlet pressure at the boiler must be within the following limits regardless of what combination of appliances is firing:
 

| Inlet Press<br>(inches w.c.) | Natural Gas | LP Gas |
|------------------------------|-------------|--------|
| Minimum                      | 4.5         | 11.0   |
| Maximum                      | 14.0        | 14.0   |
  - C. If the inlet pressure falls outside of these limits, find and correct the cause of the problem before proceeding further.
  - D. If boiler is installed with a direct vent kit, disconnect the regulator tube from the hose barb on the gas valve (Figure 11-4).
  - E. Connect a manometer to the manifold (outlet) pressure tap on the gas valve (Figure 11-2).

# 11 Start-up and Checkout *(continued)*

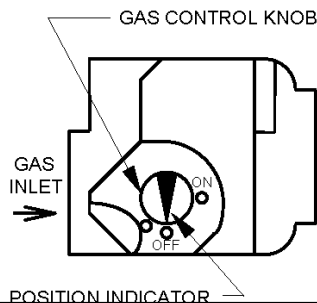
## FOR YOUR SAFETY READ BEFORE OPERATING

**WARNING:** If you do not follow these instructions exactly, a fire or explosion may result causing property damage, personal injury, or loss of life.

- A. This appliance is equipped with an ignition device which automatically lights the pilot. Do not try to light the pilot by hand.
- B. BEFORE OPERATING smell all around the appliance area for gas. Be sure to smell next to the floor because some gas is heavier than air and will settle on the floor.
- WHAT TO DO IF YOU SMELL GAS**
- ▶ Do not try to light any appliance.
  - ▶ Do not touch any electric switch; do not use any phone in your building.
  - ▶ Immediately call your gas supplier from a neighbor's phone. Follow the gas supplier's instructions.
- C. Use only your hand to push in or turn the gas control knob. Never use tools. If the knob will not push in or turn by hand, don't try to repair it, call a qualified service technician. Force or attempted repair may result in a fire or explosion.
- D. Do not use this appliance if any part has been under water. Immediately call a qualified service technician to inspect the appliance and to replace any part of the control system and any gas control which has been under water.
- ▶ If you cannot reach your gas supplier, call the fire department.

## OPERATING INSTRUCTIONS

1. STOP! Read the safety information above on this label.
2. Set the thermostat to lowest setting.
3. Turn off all electric power to the appliance.
4. This appliance is equipped with an ignition device which automatically lights the pilot. Do not try to light the pilot by hand.
5. Remove front door.
6. Locate the gas control valve at the end of the gas supply pipe going into the boiler. The gas control knob is the brown or blue plastic knob located on top of the gas control valve.
7. Rotate gas control knob clockwise from "ON" position to "OFF". Make sure knob rests against stop.
8. Wait five (5) minutes to clear out any gas. Then smell for gas, including near the floor. If you smell gas, STOP! Follow "B" in the safety information above on this label. If you do not smell gas, go to the next step.
9. Rotate gas control knob counterclockwise from "OFF" to "ON". Make sure knob rest against stop. Do not force.
10. Replace front door.
11. Turn on all electric power to the appliance.
12. Set thermostat to desired setting.
13. If the appliance will not operate, follow the instructions "TO TURN OFF GAS TO APPLIANCE" and call your service technician or gas supplier.



## TO TURN OFF GAS TO APPLIANCE

1. Set the thermostat to lowest setting.
2. Turn off all electric power to the appliance if service is to be performed.
3. Remove front door.
4. Rotate gas control knob clockwise from "ON" position to "OFF". Make sure knob rests against stop.
5. Replace front door.

Figure 11-3: Operating Instructions

## 11 Start-up and Checkout *(continued)*

F. Read the manifold pressure. It should be set at:

|                               | Natural Gas | LP Gas |
|-------------------------------|-------------|--------|
| Manifold Press. (inches w.c.) | 3.5         | 10.0   |
| within $\pm 0.3$ " w.c.       |             |        |

G. If a manifold pressure adjustment is needed, make the adjustment by turning the regulator screw (see Figure 11-2) clockwise to raise the pressure and counter-clockwise to reduce the pressure. If a manifold pressure adjustment is made, recheck the inlet pressure after making the adjustment to be certain that it is still within acceptable limits. Replace the cover screw on the regulator.

H. If boiler is installed with a direct vent kit, reconnect the regulator tube to the hose barb on the gas valve (Figure 11-4).

### ⚠ WARNING

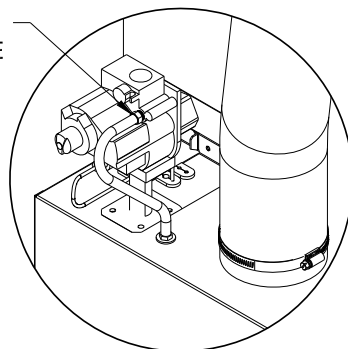
Failure to connect the regulator tube to the air box or replace the regulator screw cover after making a manifold pressure adjustment, could cause elevated CO levels on direct vent boilers resulting in personal injury or loss of life.

13. Check Main Burner Flame - See Figure 11-5. Flame should have a clearly defined inner cone with no yellow tipping. Orange-yellow streaks caused by dust should not be confused with true yellow tipping.

### ⚠ CAUTION

Avoid operating boiler in an environment where saw dust, loose insulation fibers, dry wall dust, etc. are present. If boiler is operated under these conditions, burner interior and ports must be cleaned and inspected daily to ensure proper operation.

DISCONNECT REGULATOR TUBE FROM HOSE BARB LOCATED HERE ON GAS VALVE REFERENCE PORT



**Figure 11-4: Regulator Tube Location On Gas Valve (Direct Vent Boilers Only)**

14. Check Pilot Burner Flame.

**Natural Gas Only.** Pilot produces single flame. Flame should be steady medium hard blue enveloping 3/8 to 1/2 inch of igniter/sensor tip. See Figure 11-6.

**LP Gas Only.** The pilot burner produces three (3) flames. The center flame should be steady, medium hard blue enveloping 3/8 to 1/2 inch of sensing probe. See Figure 11-7.

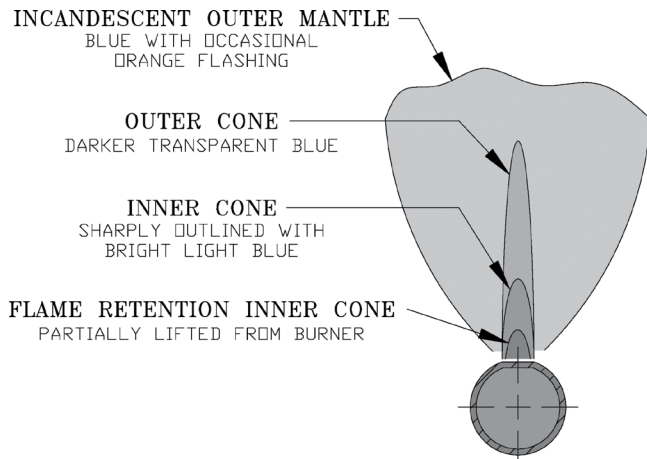
15. Gas valve safety shutdown test - With main burners firing, disconnect ignition cable from ignition module. Both pilot burner and main burners should stop firing.
16. Check High Limit Control - Jumper thermostat connections in boiler wiring harness. Allow burners to operate until shutdown by limit (factory setting is 190°F). REMOVE JUMPER WHEN TEST IS COMPLETE.
17. Check LWCO Operation - Push and hold the LWCO TEST button while the boiler is firing (Fig 11-1). The burners should shut down and the yellow light illuminate on the LWCO. Upon releasing the TEST button, the yellow light should go off and the boiler fire.
18. Check Thermostat Operation - Raise and lower temperature setting to start and stop boiler operation. Adjust thermostat to normal setting.
19. Check of External Safety Devices - Verify proper operation of any field installed safety devices, such as external limits.
20. Combustion Chamber Burn-off
- The mineral wool combustion chamber panels may contain a cornstarch based binder that must be burned out at installation to prevent odors during subsequent boiler operation.
  - Ventilate the boiler room, set the high limit to its maximum setting, set the thermostat to call for heat. Allow the boiler to fire for at least an hour or until the odor from the cornstarch has dissipated.
  - Return the high limit and thermostat to their desired settings.
21. System Leak Check - After the boiler has operated for at least 30 minutes, check the boiler and heating system piping for leaks. Repair any leaks found at once.

### ⚠ CAUTION

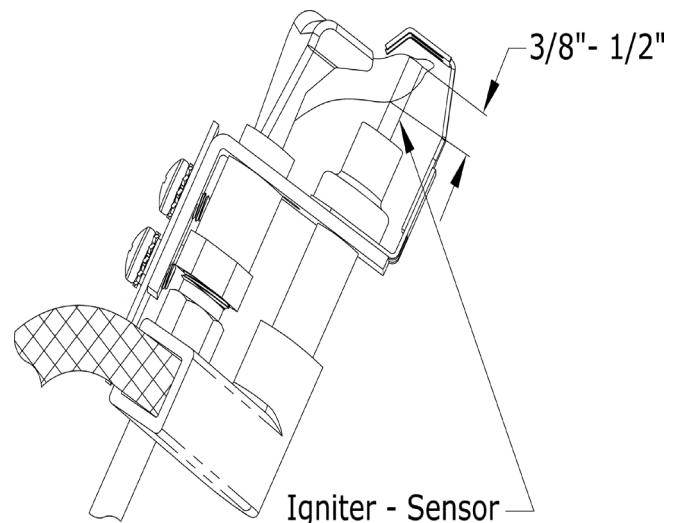
System leaks can cause severe boiler damage.

# 11 Start-up and Checkout *(continued)*

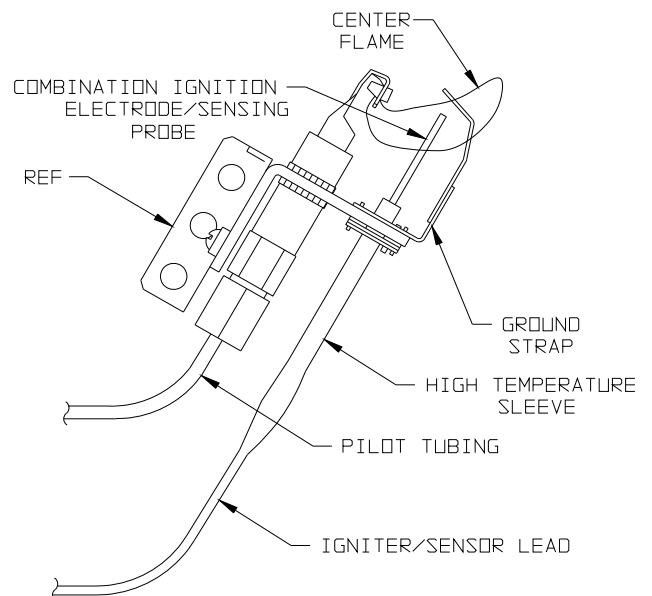
22. Inspect the vent system for flue gas leaks - Repair any leaks found before leaving the boiler in operation.
23. Review User's Information Manual and system operation with owner or operator.



**Figure 11-5: Main Burner Flame**



**Figure 11-6: Natural Gas Pilot Flame**



**Figure 11-7: LP Gas Pilot Flame**

## 12 Operation

### 1. Controls

- A. This boiler uses a proprietary version of the Honeywell S9361A “integrated boiler control” to manage all boiler functions including flame supervision, temperature control, and circulator operation. This control can operate one or two circulator zones without the use of additional relays.
- B. In accordance with the 2007 Energy and Independence Security Act, this control first attempts to use residual heat in the boiler to satisfy a space heating demand before firing the burner. In this manual, this function is referred to as a “thermal purge”. For additional information see Step 3 of this section.

### 2. Reading Status And Using Menu

The boiler’s status, as well as all parameters, are viewed and adjusted using the 3 digit LED and three buttons shown in Figure 12-1. The S9361A has four basic modes of operation (also see Figure 12-2):

- A. Status Mode - This is the default mode of operation for the control. In it, the display alternates between *5LR* and a number indicating the current status of the boiler. A list and description of these status numbers is shown in Table 12-3 and is also shown on the face of the control itself.

- B. Operating Mode - Provides additional information about the current status of the boiler. Operating mode is entered by pressing the **I** button shown in Figure 12-1. When this button is first pressed in Status mode, the display will alternately display *bL* and the current boiler water temperature as shown in Figure 12-4. Pressing the **I** button again will display the next line item shown in Table 12-3. In the same manner it is possible to advance through all of the “parameters” shown in Table 12-3. To return to Status mode, press **I** repeatedly until *5LR* once again appears on the display. Alternatively, the control will return to Status mode if no key is touched for 30 minutes.
- C. Error Mode - In Error mode, the control alternately displays *Err* and an error code. A list of these error codes is found on the front of the control, as well as in Section 16 of this manual (along with suggested corrective actions).

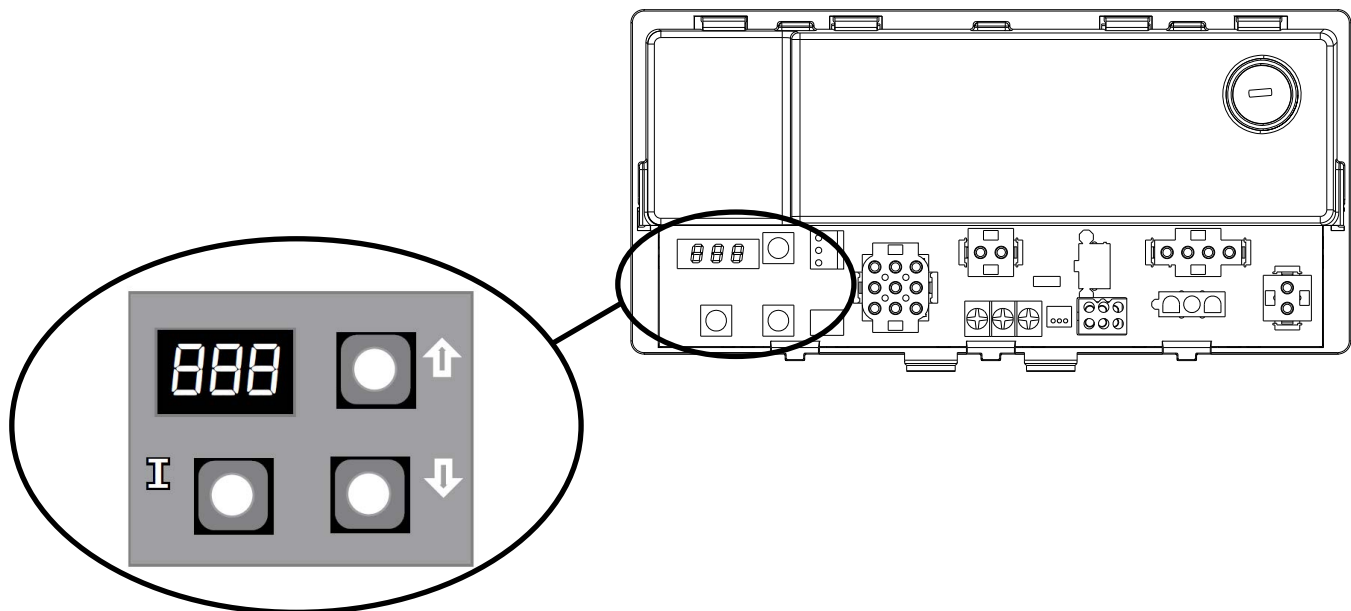
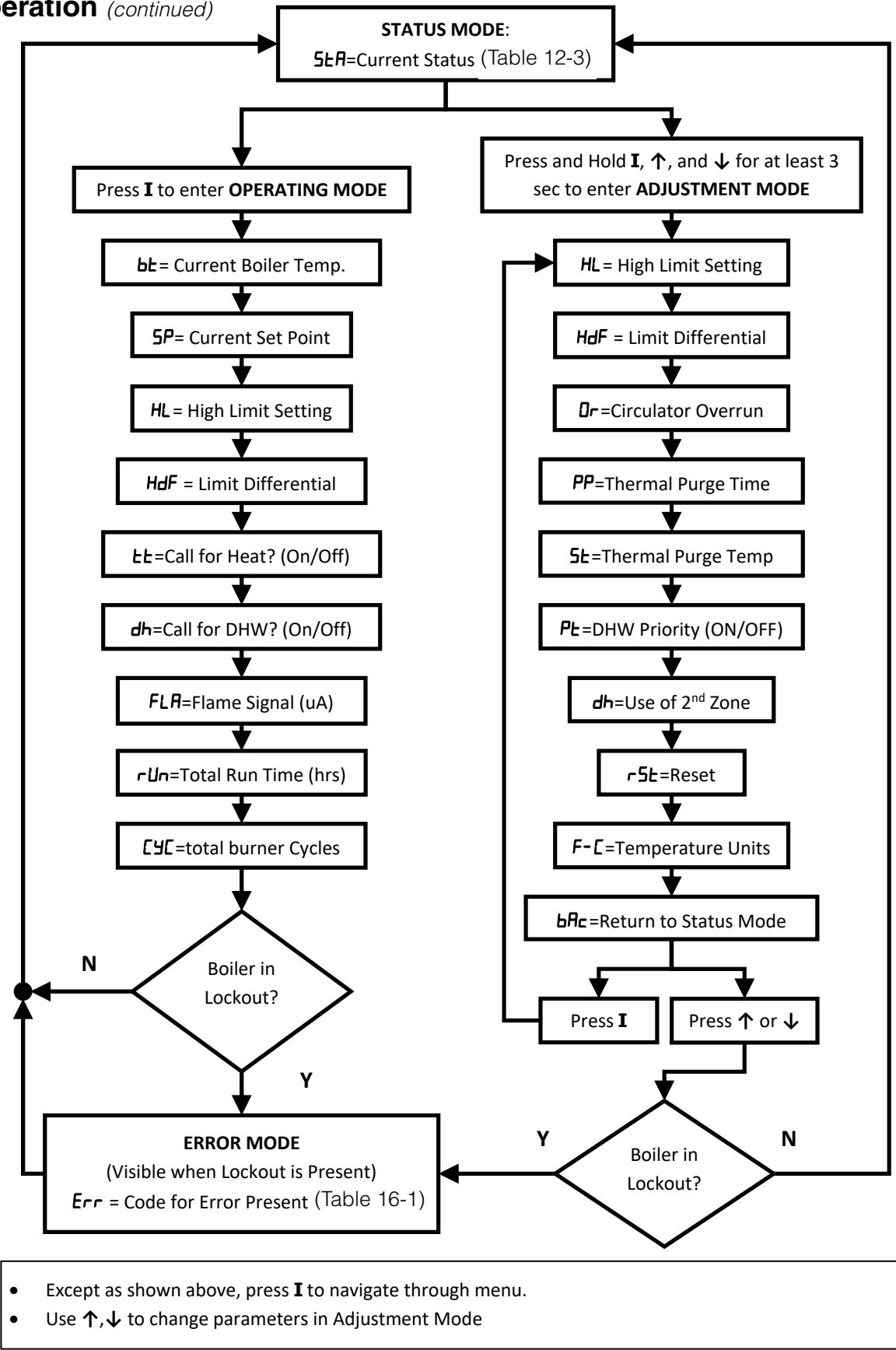


Figure 12-1: Location/Appearance Of LED, Buttons

# 12 Operation *(continued)*



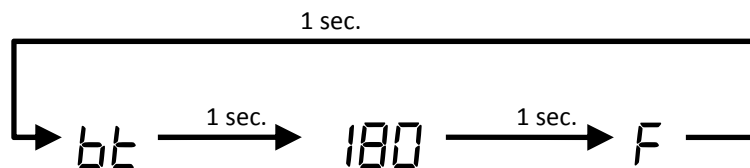
- Except as shown above, press **I** to navigate through menu.
- Use **↑, ↓** to change parameters in Adjustment Mode

Figure 12-2: Boiler Control Menu

## 12 Operation *(continued)*

**Table 12-3: Status Codes**

| Status # | Description                          | Meaning   |
|----------|--------------------------------------|---|
| 1        | Standby                              | No call for heat or DHW<br>OR<br>Call for heat present , but boiler is in thermal purge (See PP on page 39)<br>OR<br>Call for heat/DHW present but boiler temperature is above high limit (HL) setting.                           |
| 2        | Waiting for Pressure Switch to open  | Control is confirming that air pressure switch contacts are open before starting fan.   |
| 3        | Waiting for Pressure Switch to close | Fan is on and control is waiting for air pressure switch contacts to close.   |
| 4        | Prepurge                             | Pressure switch is closed and control is waiting 30s before starting trial for ignition.  |
| 6        | Spark                                | Control is attempting to light pilot  |
| 7        | Flame proving                        | Control is verifying that the pilot flame is on and stable.   |
| 8        | Running                              | Main burner is on   |
| 10       | Retry/Recycle Delay                  | Control was unable to establish pilot and is waiting 60 seconds before trying again<br>OR<br>Proof of pilot was lost after pilot was established and control is waiting 60 seconds before attempting to relight.                  |
| 11       | Pressure Switch failed to open.      | Control waited in Status #2 for 60 seconds and air pressure switch remained closed. Boiler will remain in this state until the air pressure switch opens.   |
| 12       | Pressure Switch failed to close.     | Control waited in Status #3 for 60 seconds and air pressure switch failed to close. Boiler will remain in this state until the air pressure switch closes.  |
| 13       | Soft Lockout                         | A fault is preventing the boiler from firing. Boiler will be allowed to fire after problem clears itself AND a forced delay period has passed.  |
| 14       | Hard Lockout                         | A fault has occurred which requires manual intervention before the boiler will again operate. This intervention can be in the form of interruption of the power supply to the boiler or resetting the control in Adjustment mode. |
| 15       | Waiting for limit to close           | LWCO open, limit jumper plug missing, or flame rollout switch open  |
| 16       | Flame Present out of Sequence        | A flame was detected when none should have been present.  |
| 17       | Self test                            | Boiler was just energized and control is running a self check.  |


**Figure 12-4: Typical Operating Mode Display (Boiler Temp Shown)**

**Note:** In operating mode, holding either the  $\uparrow$  or  $\downarrow$  button while viewing a given parameter will keep the display on the actual reading. For example, pressing  $\uparrow$  while reading boiler temperature as shown in Figure 12-4 will keep the display on 180 for as long as the button is held. This makes it easier to view readings “live” if they are changing rapidly.

## 12 Operation *(continued)*

**Table 12-5: Operating Mode Parameters**

| Parameter #                      | Description             | Meaning  |
|----------------------------------|-------------------------|--|
| <i>b<sub>t</sub></i>             | Boiler Temperature      | Current boiler water temperature measured by the control's sensor.   |
| <i>S<sub>P</sub></i>             | Boiler water set point  | Current target temperature (always the same as the high limit setting unless the outdoor reset card option is installed).  |
| <i>H<sub>L</sub></i>             | High Limit Set point    | Boiler will stop firing if boiler water temperature exceeds this value (Circulator/s will continue to operate)   |
| <i>H<sub>dF</sub></i>            | High Limit Differential | If high limit setting is reached, boiler water temperature will need to drop by this amount before boiler will again fire during the same call for heat.   |
| <i>t<sub>t</sub></i>             | Heat Request Status     | Shown as either ON or OFF. Indicates whether there is a call for heat.   |
| <i>d<sub>h</sub></i>             | DHW Request Status      | Shown as either ON or OFF. Indicates whether there is a call for domestic hot water (DHW). Note that if the dh zone on the S9361A is used as a second heating zone (see Table 12-6), this parameter will be shown as OFF and tt will be shown as ON when this zone calls for heat. |
| <i>F<sub>L<sub>A</sub></sub></i> | Flame Current           | Flame rectification signal (uA)  |
| <i>r<sub>U<sub>n</sub></sub></i> | Run Time Hours          | Total amount of time gas valve has been open (burner firing) since control was new (hours, starting from 1).   |
| <i>C<sub>Y<sub>C</sub></sub></i> | Boiler Cycles           | Total number of burner cycles on the control   |
| <i>E<sub>r<sub>r</sub></sub></i> | Error Number            | Present only if the control has detected a problem. See Table 16-1 for a list of error codes and suggested corrections.  |

**Table 12-6: Adjustment Mode Parameters**

| Status #                         | Description              | Factory Setting | Permissible Range                         |
|----------------------------------|--------------------------|-----------------|---|
| <i>H<sub>L</sub></i>             | High Limit Set point     | 180°F           | 140-220°F                                 |
| <i>d<sub>F</sub></i>             | High Limit Differential  | 15°F            | 10-30°F                                   |
| <i>O<sub>r</sub></i>             | Circulator overrun       | 0 min           | 0-10 minutes                              |
| <i>P<sub>P</sub></i>             | Thermal Purge time       | 2 min           | 2-20 minutes                              |
| <i>S<sub>t</sub></i>             | Thermal Purge Start Temp | 140°F           | 140-180°F                                 |
| <i>P<sub>t</sub></i>             | DHW Priority             | ON              | ON or OFF                                 |
| <i>d<sub>h</sub></i>             | Use of Second Zone       | dh              | dh (dhw)<br>or<br>tt2 (2nd heating zone). |
| <i>r<sub>S<sub>t</sub></sub></i> | Reset                    | N/A             | OFF or<br>Momentary ON                    |
| <i>F-<sub>C</sub></i>            | Temperature Units        | F               | F or C                                    |
| <i>b<sub>A<sub>c</sub></sub></i> | Exit Adj. mode           | N/A             | N/A                                       |

## 12 Operation *(continued)*

### WARNING

Improper adjustments to control parameters could result in unreliable boiler operation, property damage, personal injury, or loss of life. Adjustments should only be made by a qualified heating technician.

#### 3. Using Adjustment Mode

A list of parameters which can be changed on this control are shown in Table 12-6. To enter Adjustment mode and change parameters:

- A. Press and hold **I**, **↑**, **↓** together for at least 3 seconds.
- B. Use **I** to advance to the parameter which is to be changed.
- C. Use the **↑** or **↓** buttons to change the setting or select from possible choices. See below for additional information on the use of these parameters.
- D. If other parameters are to be changed, use the **I** button to advance to the next parameter needing adjustment and change it in the same way.
- E. After all parameters have been changed, use the **I** button to advance until **bPc** is shown on the display.
- F. Press either the **↑** or **↓** key to return to Status mode. Alternatively, the control will return to Status mode if no key is touched for 5 minutes.

**HL** (High limit Set point) - Burners shut down if the boiler water temperature exceeds this setting. The circulator will continue to run. The high limit setting also serves as the water temperature set point (**5P**) during calls for both heat and DHW.

**dF** (High limit differential) - If the boiler shuts off on high limit, the water temperature must fall by an amount equal to the differential during the same call for heat before the burners will again start. For example, with HL=180 and dF=15, the burners will shut off if the water temperature exceeds 180F and stay off until the temperature falls to 165F (180 - 15). Note that if all calls for heat end while the burners are off on high limit, the burner will not restart during the next call for heat until the thermal purge requirements described below are met.

**Or** (Circulator Overrun) - Determines how long the Heating Circulator will operate after the call for heat ends. In some cases, this can help reduce energy consumption by sending heat stored in the boiler out into the system. At the same time, caution

should be exercised before setting this value to something other than zero. Before doing so, verify that the system will permit flow (e.g. flow is not completely cut-off by closed zone valves) and that the overrun will not cause overheating problems. Circulator overrun is only possible on the heating zone. The DHW Circulator will not over-run, even if the DHW zone is used as a second heating zone.

**PP** (Thermal Purge Time) - Upon a call for heat, the boiler will prevent burner operation until either:

- The water temperature drops below the Thermal Purge start temperature (**5E**) OR:
- The thermal purge time has passed

For some examples of this operation, see Table 12-7. If the "DHW" zone is used for space heating (dh=tt2), this thermal purge function will also keep the burner off at the beginning of a call from the thermostat connected to the "DHW" terminals in the manner described above. If the "DHW" zone is being used for DHW (dh=dh), the burners will immediately come on upon a call for DHW as long as the water temperature is below the high limit setting.

Thermal purge is only invoked when a call for heat first appears and the boiler is not already firing. For this reason, if the boiler is already firing in response to an call for heat, and a call for heat appears at the second zone, the boiler will continue to fire.

**5E** (Thermal Purge Start Temperature) - See description for Thermal Purge Time above.

**Pc** (DHW Priority) - If this feature is turned on, and simultaneous calls for heat and DHW are present, the heating circulator will be forced off for as long as it takes the boiler to satisfy the call for DHW. This feature is sometimes useful when the boiler size is marginal for the peak DHW demand, but should be used with caution as it can result in lack of heat if the DHW call is very long, or if there is a problem with the DHW zone which causes the DHW demand to be indefinite. Figure 12-8 describes the behavior of both the Heating and DHW Circulators with **Pc** turned both ON and OFF.

**dh** (Use of DHW zone) - Although the second zone on the boiler is designated "DHW", it can be used as a second heating zone by setting dh = "tt2" instead of dh="dh". When the "DHW" zone is used for heating, the thermal purge function is active when this zone calls for heat. When dh=tt2, the setting of **Pc** (DHW priority) is ignored.

## 12 Operation *(continued)*

**r5E (Reset)** - Used to reset the boiler from a hard lockout (as an alternative to momentarily interrupting power to the control). Pressing the up key will turn r5E momentarily to on. When it goes back off (typically within one or two seconds), the control is reset.

**F-L (Temperature Units)** - Determines whether temperature units on the S9361A are displayed in F or C. Note that this selection only applies to the temperature displayed on the LED shown in Figure 12-1.

**bRc (Return to Status mode)** - Exits adjustment mode. Any changes made to the parameters described above are saved, and become effective, as soon as they are made; bRc only exits adjustment mode.

**Table 12-7: Examples Of Thermal Purge Operation**

| Example # | Call for Heat From           | Use of DHW Zone | Thermal Purge Settings |                 | Boiler Temp at Begin Call | Boiler Behavior   |
|-----------|------------------------------|-----------------|------------------------|-----------------|---------------------------|---|
|           |                              |                 | Time (Pt)              | Start Temp (St) |                           |   |
| 1         | T-T                          | N/A             | 2 min.                 | 140°F           | 130                       | <ul style="list-style-type: none"> <li>• Heating Circulator starts immediately</li> <li>• Burner fires immediately</li> </ul>   |
| 2         | T-T                          | N/A             | 2 min.                 | 140°F           | 150                       | <ul style="list-style-type: none"> <li>• Heating Circulator starts immediately</li> <li>• Burner fires when either:<br/>2 minutes have passed<br/>OR<br/>Temperature falls below 140</li> </ul> |
| 3         | DHW                          | DHW (dh=dh)     | 2 min.                 | 140°F           | 150                       | <ul style="list-style-type: none"> <li>• DHW Circulator starts immediately</li> <li>• Burner fires immediately</li> </ul>   |
| 4         | Heat T'stat on DHW terminals | Heat (dh=ttt)   | 2 min.                 | 140°F           | 150                       | <ul style="list-style-type: none"> <li>• "DHW" Circulator starts immediately</li> <li>• Burner fires when either:<br/>2 minutes have passed<br/>OR<br/>Temperature falls below 140</li> </ul>   |
| 5         | T-T                          | N/A             | 2 min.                 | 145°F           | 150                       | <ul style="list-style-type: none"> <li>• Heating Circulator starts immediately</li> <li>• Burner fires when either:<br/>2 minutes have passed<br/>OR<br/>Temperature falls below 145</li> </ul> |
| 6         | T-T                          | N/A             | 3 min.                 | 140             | 150                       | <ul style="list-style-type: none"> <li>• Heating Circulator starts immediately</li> <li>• Burner fires when either:<br/>3 minutes have passed<br/>OR<br/>Temperature falls below 140</li> </ul> |

## 12 Operation *(continued)*

### 4. Sequence Of Operation

(Refer to Figures 10-3 or 10-4 for Connection and Ladder diagrams)

- A. A call for heat from the thermostat energizes the Heating Circulator (connected to yellow and white leads in j-box).
- B. Depending on the boiler water temperature at the time of the call for heat, the control will do one of two things:
  - If the water temperature is below the thermal purge start temperature ( $5t$ ), the control will continue the ignition sequence.
  - If the boiler water temperature is above the thermal purge start temperature, the boiler will wait until either of the following conditions are met before continuing the ignition sequence:
    - i. The boiler water temperature falls below the thermal purge start temperature ( $St$ ) Factory default is 140°F.
    - ii. The thermal purge time elapses ( $PP$ ). Factory default is 2 minutes.
- C. If the flame roll-out switch, and LWCO contacts are made, the control will verify that the air pressure switch (APS) is open before starting the fan.
- D. The control energizes the fan and waits for the air pressure switch to close.
- E. Once the air pressure switch closes, the control waits for a 30s "prepurge period" to pass before attempting to light the pilot.
- F. The control starts an ignition spark at the pilot and applies 24 volts across the pilot valve (terminals PV and MV/PV on the gas valve).
- G. Once the pilot is established, the pilot flame will act as a diode, converting the AC current at the electrode to a half wave DC current at the pilot's ground strap. This DC current flows through the boiler to the ground connection on the S9361A. For the ignition module to recognize that a pilot flame is present, the DC current flowing into this terminal must be in excess of approximately 1.0  $\mu A$ .
- H. If the pilot is not proven within 60 seconds of the beginning of the trial for ignition, the pilot valve will close and wait 5 minutes before the ignition sequence is retried.
- I. Once the ignition module detects the presence of a pilot flame, voltage is applied across the main valve (terminals MV and MV/PV on the valve), opening the valve and establishing main flame.
- J. If the water temperature climbs above the high limit setting during the call for heat, the burner and blower will shut down while the Heating Circulator continues to operate. The ignition sequence will restart (from Step 3) when the water temperature falls to the high limit setting ( $HL$ ) minus the high limit differential ( $HdF$ ).
- K. A call for DHW results in a sequence of operation that is identical to that described above except for omission of the thermal purge function described in (2).

## 12 Operation *(continued)*

**Table 12-8: Summary of Circulator Behavior**

| Thermostat Inputs |       | Use of "DHW"<br>Zone | Parameters    |                      | Circulator Outputs             |                           |
|-------------------|-------|----------------------|---------------|----------------------|--------------------------------|---------------------------|
| T-T               | "DHW" |                      | 2nd Zone (dh) | DHW<br>Priority (Pt) | Heating<br>(Yellow Circ. Lead) | "DHW"<br>(Red Circ. Lead) |
| ON                | OFF   | DHW                  | dh=dh         | On                   | ON                             | OFF                       |
| OFF               | ON    | DHW                  | dh=dh         | On                   | OFF                            | ON                        |
| ON                | ON    | DHW                  | dh=dh         | On                   | OFF                            | ON                        |
| ON                | ON    | DHW                  | dh=dh         | OFF                  | ON                             | ON                        |
| ON                | OFF   | DHW                  | dh=dh         | OFF                  | ON                             | OFF                       |
| OFF               | ON    | DHW                  | dh=dh         | OFF                  | OFF                            | ON                        |
| ON                | OFF   | Heat                 | dh=tt?        | On or OFF            | ON                             | OFF                       |
| OFF               | ON    | Heat                 | dh=tt?        | On or OFF            | OFF                            | ON                        |
| ON                | ON    | Heat                 | dh=tt?        | On or OFF            | ON                             | ON                        |

### 5. Safety Control Operation

Air Pressure Switch (APS) - The APS proves that the fan is running before allowing the ignition sequence to proceed. Failure of this switch to close is usually the result of a problem with the vent system, such as a blockage, or a problem with the fan. If this switch must be replaced, it must be replaced with an identical switch or one that is shown in this documentation as being a suitable replacement for this boiler (see Service Parts Section of boiler installation manual).

IDL 1200 Low Water Cut Off- The IDL 1200 Low Water Cut-Off is designed to protect from potentially damaging low water conditions in the boiler. In the event of a low water condition, the "LOW WATER" LED will turn on and the control will shutdown the burner.

## 13 Before Leaving Jobsite

Before Leaving Jobsite:

- Checked CO Alarm Installed
- Boiler and system filled with water
- Performed gas leak test
- Checked pilot burner flame
- Checked main burner flames
- Checked gas input rate
- Checked gas inlet pressure
- Checked gas manifold pressure
- Checked CO level in vent
- Check ignition system safety shut-off device
- Tested LWCO functionality
- Tested high limit operation
- Tested additional field-installed controls for functionality outlined by manufacturer. (i.e. additional LWCO, additional high limit, or other controls if used)
- Reviewed User's Information Manual and system operation with owner or operator

# 14 Service and Maintenance

## Important Product Safety Information: Refractory Ceramic Fiber Product

### WARNING

Some boiler components use materials that contain refractory ceramic fibers (RCF). RCF has been classified as a possible human carcinogen. When exposed to elevated temperatures, RCF may change into crystalline silica, a known carcinogen. When disturbed as a result of servicing or repair, these substances become airborne and, if inhaled, may be hazardous to your health. Avoid breathing RCF particulates and dust.

#### Precautionary Measures:

- Do not handle RCF parts or attempt any service or repair work involving RCF without wearing the following protective gear:
  1. A properly fitting National Institute for Occupational Safety and Health (NIOSH)-certified air-purifying respirator with a filter efficiency of at least 95%. Respirator should also include a full facepiece when handling used RCF. Other types of respirators may be required depending on site conditions. Current NIOSH recommendations may be found on the NIOSH website <http://www.cdc.gov/niosh/index.html>. NIOSH-approved manufacturers, respirators and associated user instructions are listed on the NIOSH website.
  2. Long sleeved, loose fitting clothing that is sufficiently tight around potential entry points for RCF dust.
  3. Gloves.
  4. Eye protection, such as goggles, safety glasses with side shields, or full facepiece.
- Take steps to assure adequate ventilation.
- Handle RCF carefully to minimize airborne dust. Use hand tools whenever possible.
- Dampen used RCF with light water spray prior to removal to prevent airborne dust.
- Do not use compressed air or dry sweeping for clean-up. Frequently clean work area with a vacuum or by wet sweeping to minimize debris accumulation.
- Vacuum work clothes before leaving work area. Wash work clothes separately from other laundry and rinse washing machine after use to avoid contaminating other clothes.
- Wash all exposed body areas gently with soap and water after contact.
- Discard used RCF components by sealing in an airtight plastic bag or container. Refer to local, regional, state or provincial regulations to identify applicable disposal requirements.

#### First Aid Procedures:

- Eye contact: Flush with water for at least 15 minutes. **Do not rub eyes.** Seek immediate medical attention if irritation persists.
- Skin contact: Wash affected area gently with soap and water. Do not rub or scratch affected skin. Seek immediate medical attention if irritation persists.
- Nose and throat contact: If these become irritated, leave the area and move to a location with clean fresh air. Drink water and blow nose. Seek immediate medical attention if symptoms persist.

112645-01

## 14 Service and Maintenance *(continued)*

### ⚠ WARNING

This boiler should be serviced by a qualified installer, service agency, or gas supplier. Inspections should be performed at intervals specified in this manual. Maintain manual in a legible condition.

- Keep boiler area clear and free of combustible materials, gasoline and other flammable vapors and liquids.
- Do not place any obstructions in boiler room that will hinder flow of combustion and ventilation air.
- Failure to maintain the boiler in proper working condition may lead to fire, explosion, personal injury or death and extensive property damage.
- Turn off all gas and electric power supplies to the boiler before servicing. Contact with or release of dangerous flammable gas, electrical voltage, moving parts and very hot water under pressure may cause serious personal injury, property damage or death.
- Lock electrical boxes and gas valves closed to prevent someone from inadvertently restoring power or gas before the heating system is safe to operate.
- Water leaks can cause severe corrosion damage to the boiler or other system components. Repair any leaks found immediately.

### ⚠ DANGER

**Explosion Hazard. Electrical Shock Hazard. Burn Hazard.** This boiler uses flammable gas, high voltage electricity moving parts, and steam under pressure. Assure that all gas and electric power supplies are turned off. Make sure boiler is not under pressure and temperature is cool before attempting any disassembly for service. Do not rely solely on pressure gauge to make this determination.

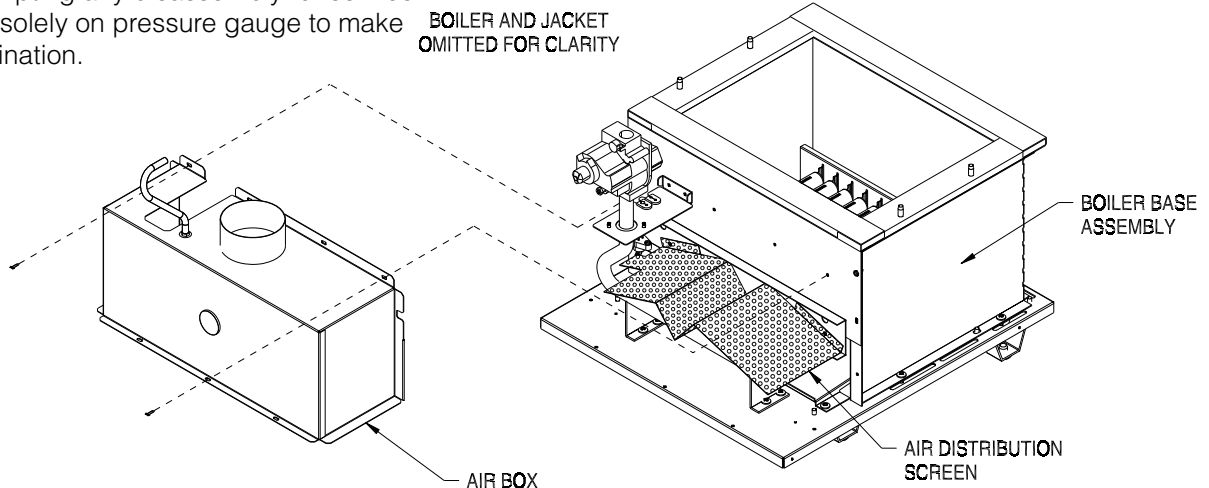


Figure 14-1: Direct Vent Air Box Removal

### ⚠ CAUTION

Label all wires prior to disconnection when servicing controls. Wiring errors can cause improper and dangerous operation. Verify proper operation after servicing.

ATTENTION. Au moment de l'entretien des commandes, étiquetez tous les fils avant de les débrancher. Les erreurs de câblage peuvent nuire au bon fonctionnement et être dangereuses. S'assurer que l'appareil fonctionne adéquatement une fois l'entretien terminé.

1. Annual Maintenance
  - A. Turn off electrical power and gas supply to the boiler.
  - B. Inspect the flue passages for signs of blockage. If there is any carbon in the combustion chamber or the flue passages, clean the heat exchanger before proceeding further. See the cleaning procedure below.
  - C. Remove all burners, noting the location of the pilot main burner. If burners show signs of deterioration, they should be replaced (some discoloration around the burner ports is normal). Clean the burners by first brushing the ports with a soft bristle brush and then vacuuming out any debris through the venturi opening.

**NOTICE:** If the boiler is equipped with a **Direct Vent Conversion Kit**, it will be necessary to remove the air intake box from the boiler in order to access the burners and combustion chamber. This is done by disconnecting the air intake hose and regulator reference hose from the boiler and then removing the mounting screws holding the box in place shown in Figure 14-1.

## 14 Service and Maintenance *(continued)*

### WARNING

Soot deposits in the flue passages are a sign that the boiler may be operating at high carbon monoxide (CO) levels. After cleaning the boiler of soot deposits, check the CO level in the flue gas to insure that the boiler is operating properly.

If it is necessary to check CO, use a combustion analyzer, or other instrument which is designed to measure CO in flue gas. A CO “sniffer” designed for testing CO levels in ambient air cannot be used to check boiler combustion. Take a flue gas sample by inserting a sample probe through the vent terminal. Do not take a sample until the boiler has been firing for at least five minutes. A normal CO reading for this series boiler is less than 50ppm (0.005%). A reading of more than 100ppm (0.01%) is indicative of a combustion problem.

Some causes of excessive CO include:

- Incorrectly sized or drilled burner orifice
  - Partially plugged flue passages
  - Improper manifold pressure
  - Partial blockage of vent or intake system
  - Foreign material in burner venturis or burner ports
  - Damaged fan impeller or housing
  - Damaged or missing fan gasket
  - Leak in seal between canopy and heat exchanger
  - Distorted or missing combustion chamber floor or baffles
  - Damaged base
- D. Remove any debris found in the combustion chamber, being careful not to disturb combustion chamber insulation.
- E. Inspect the pilot assembly. Clean any deposits found on the electrode and grounding strap. The ideal gap between the electrode and the ground strap is 1/8 in. Inspect the porcelain for cracks or other deterioration. Replace pilot assembly if deterioration is found.
- F. Inspect the base insulation for deterioration. Replace if necessary.
- G. Inspect the ignition cable insulation for cracks or other deterioration. If deterioration is found, replace cable.
- H. Reinstall burners, being careful to put the pilot main burner in its original location.
- I. Inspect all boiler wiring for loose connections or deterioration.
- J. Inspect the vent system:
- Make sure that the vent system, and condensate disposal system, is free of obstructions. Clean as necessary.
  - Make sure that all vent system supports are intact.
  - Inspect joints for signs of condensate or flue gas leakage.
  - Inspect venting components for corrosion or other deterioration. Replace any defective vent components.
- K. Inspect the boiler and hydronic system for leaks.
- L. If the boiler is equipped with a Direct Vent Conversion Kit:
- Check the air intake system, including the air inlet terminal and air distribution screen (Fig 14-1), for blockages, corrosion, or other deterioration.
  - Verify that the regulator reference hose is clear and has not deteriorated.
- M. Place the boiler back in operation using the procedure outlined in “Start-up”. Check the pilot line and any other gas piping disturbed during the inspection process for leaks.

### WARNING

Be careful handling pilot tubing. Do not crimp or crack pilot tube. Leaking pilot tubing could result in serious injury, or substantial property damage.

### DANGER

#### **Explosion Hazard.**

Do not use matches, candles, open flames, or other ignition sources to check for leaks. Failure to comply could result in severe personal injury, death, or substantial property damage.

## 14 Service and Maintenance *(continued)*

### 2. Heat Exchanger Cleaning Procedure

- A. Turn off electrical power and gas supply to the boiler.
- B. Remove the burner door, pilot, and all burners.
- C. Disconnect the vent system by removing the screws shown in Figure 7-10 and sliding the vent adaptor off of the fan.
- D. Remove the top jacket panel. If possible, remove the rear and left side jacket panels.
- E. Unplug the fan.
- F. Disconnect the pressure switch hoses from the pressure switch being careful to note their orientation.
- G. Remove the four #10 sheet metal screws holding the canopy onto the block. Also remove the four sheet metal screws securing the canopy to the side jacket panels.
- H. Remove the canopy/fan from the heat exchanger.
- I. Carefully remove the canopy gasket strips and set them aside.
- J. Remove the stainless steel flue baffles from the flue passages. Clean them of any deposits and set them aside.
- K. Clean the flue passageways using a stiff bristle brush. Be certain that all foreign material is removed from the gaps between the pins.
- L. Clean the bottom surfaces of the heat exchanger.

- M. Put a light in the combustion chamber and look through the flue passages from the top to verify that they have been thoroughly cleaned.
- N. Replace the canopy gasket strips. If desired, RTV-732 silicone sealant with a 500°F intermittent duty temperature rating may be substituted for this rope gasket. The canopy must be thoroughly sealed to the heat exchanger.
- O. Reassemble the rest of the boiler in reverse order of above. Be sure to reinstall the vent securing screw removed in step C. If this screw has deteriorated, replace it.

### 3. Service Notes

- A. Pressure Switch – This boiler is equipped with a differential pressure switch which makes when there is adequate flue gas flow through the boiler. This switch measures the pressure drop across an orifice plate inside the flue collector; the higher the flue gas flow through this plate, the higher the pressure drop. The N.O. contacts on the pressure switch make, allowing the boiler to fire, when the pressure drop across the flue collector orifice plate switch exceeds the “make setting” shown in Table 14-1. Once the switch is made, the boiler will fire as long as the pressure at the switch is above the “break setting” shown in Table 14-2. The pressure at both pressure switch tapings is actually below atmospheric (“negative”) with the pressure at the front flue collector tap being the more negative of the two pressures. Figure 14-3a shows the pressure switch connections.

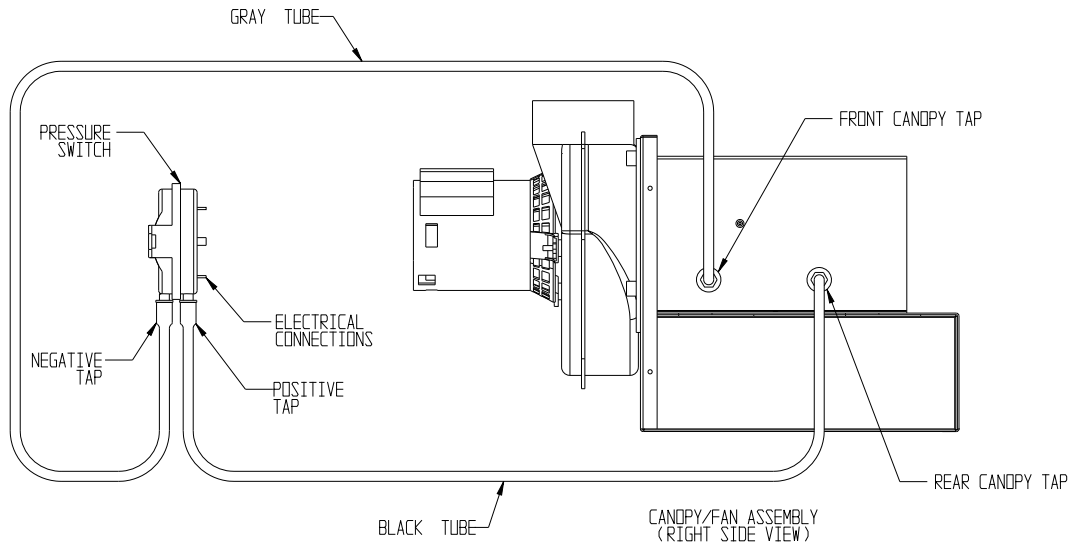
Figure 14-3b shows the correct method of reading the pressure across the pressure switch tapings. It is normal for the pressure reading across the switch to drop as the boiler heats up.

**Table 14-2: Pressure Switch Settings**

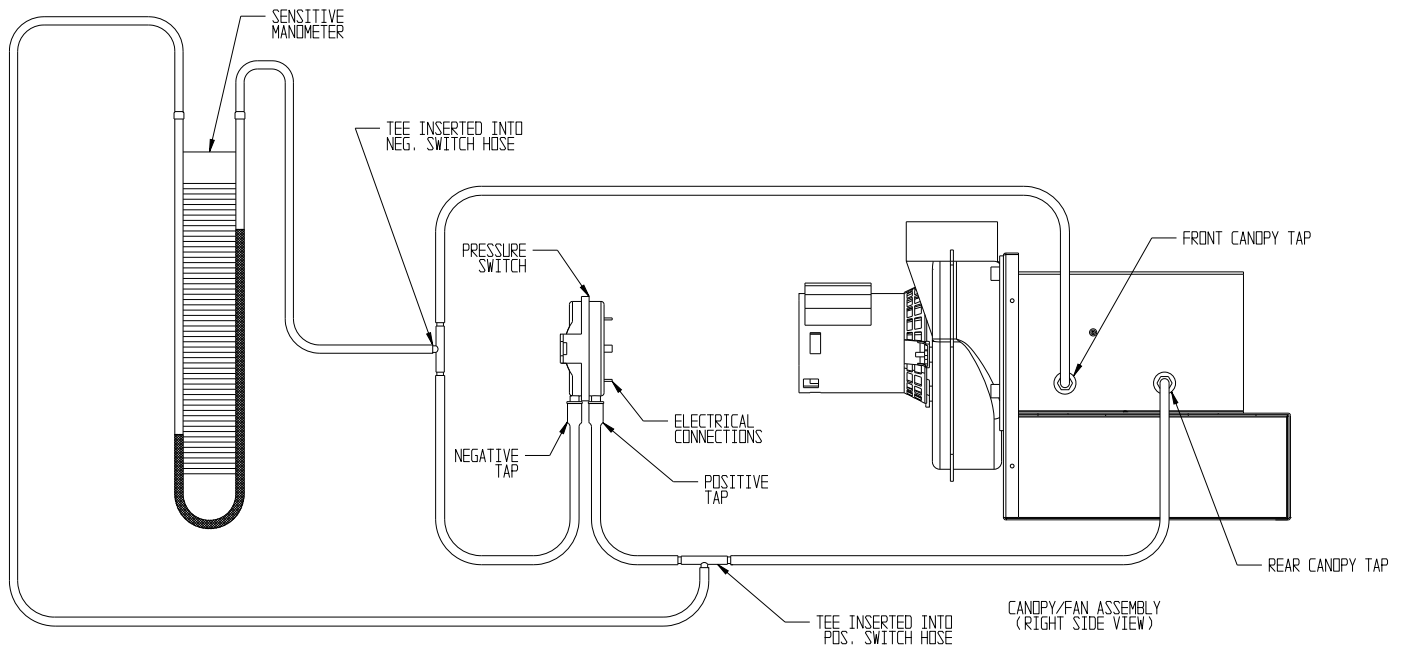
| FACTORY PN | APPROX. MAKE SETTING (inches w.c.) | BREAK SETTING* (inches w.c.) |
|------------|------------------------------------|------------------------------|
| 109839-01  | 1.32                               | 1.24                         |

\*Settings shown are based on “plus tolerance” - actual setting may be lower.

# 14 Service and Maintenance *(continued)*



**Figure 14-3a: Pressure Switch Connections**



**Figure 14-3b: Measuring Pressure Across Pressure Switch**

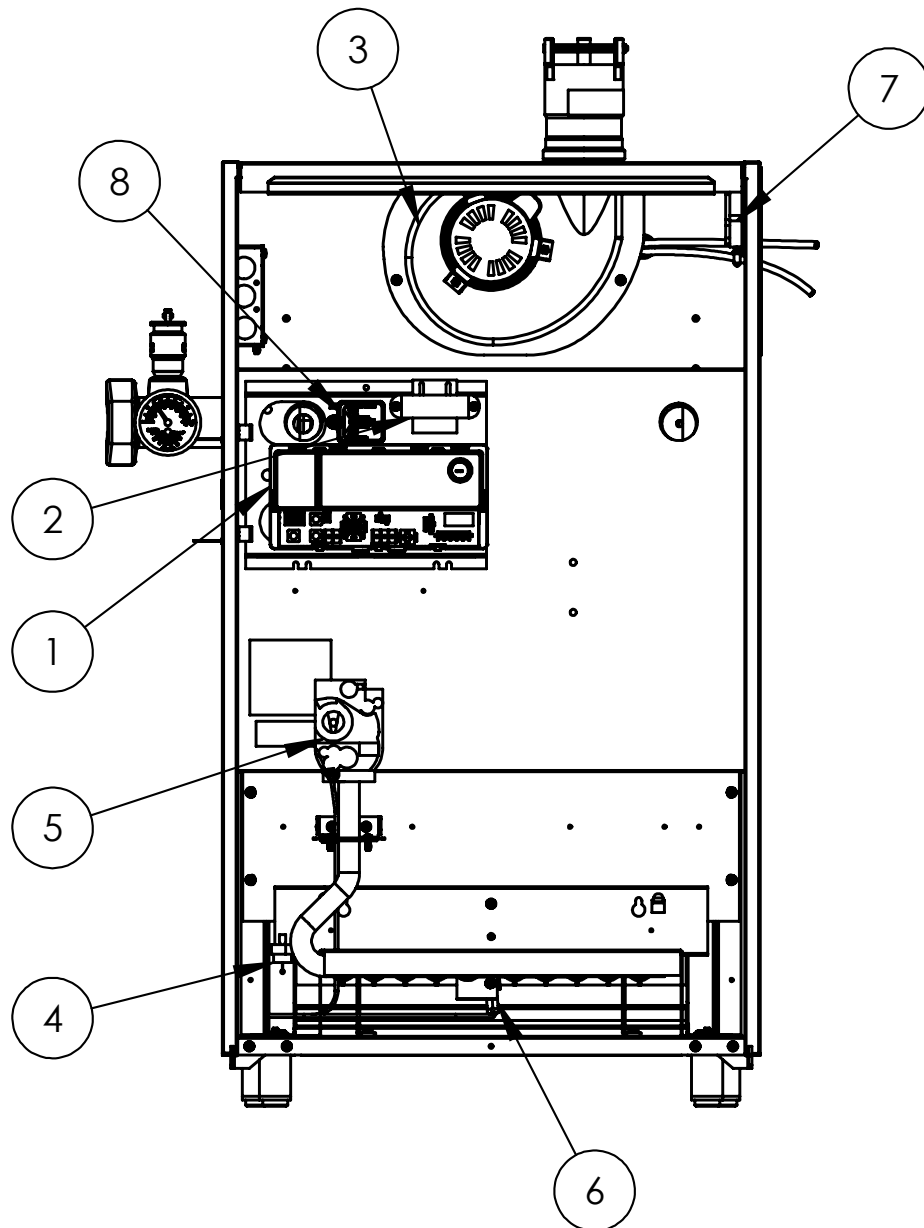
## 15 How It Works

|   |   |  |
|---|---|--|
| 1 | Control   | Boiler is equipped with an Integrated Boiler Control. This control combines features such as ignition control, high limit switch, and circulator relays. Energy is saved by using a thermal purge feature that starts the circulator and delays burner start when residual heat is available in boiler.  |
|   |   | When thermostat calls for heat, control module starts system circulator, checks safety limits, and activates fan.  |
|   |   | Fan will run and wait for air pressure switch to close.  |
|   |   | Once air pressure switch closes and a 30s prepurge period has passed, control module opens pilot valve and activates ignition spark.   |
|   |   | Control module will sense pilot flame. Once pilot flame is established, control module opens gas valve and main burners will ignite.   |
|   |   | When thermostat is satisfied, control module turns off gas valve, deactivates fan, and deactivates circulator.   |
|   |   | Control module indicates boiler status and returns error codes if applicable. See "Troubleshooting" for guidance with error codes.   |
| 2 | Transformer   | Control transformer reduces line voltage to 24 volts for gas valve and safety limit circuit.   |
| 3 | Fan   | Provides induced draft to vent products of combustion.   |
| 4 | Flame Roll-Out Switch                                 | If flames roll out of burner tubes, switch will open (requiring replacement) and cause burners to shut down. If switch trips, determine cause of flame roll-out.   |
| 5 | Gas Valve   | Regulates gas flow to boiler.  |
| 6 | Pilot   | Provides ignition source for burner lighting.  |
| 7 | Pressure Switch                                       | If vent becomes blocked, switch will open and cause burners to shut down.  |
| 8 | IDL 1200 Temperature Sensor/ Low Water Cut Off (LWCO) | Dual sensor for boiler temperature control and protection against potentially damaging low water conditions in boiler. In event of low water condition, "LOW WATER" LED will turn on and control will shutdown burner. Auto reset function allows boiler to fire when water level is returned to normal. |

### WARNING

- An open pressure switch is indicative of a problem with the vent system. If pressure switch opens, the cause of the venting problem must be found and corrected by a qualified installer, service agency, or gas supplier before placing the boiler back in operation.
- An open flame rollout switch is usually indicative of a plugged heat exchanger. Cause of the flame rollout must be found and corrected by a qualified installed, service agency, or gas supplier, and switch replaced with an identical one, before the boiler is returned to operation.

# 15 How It Works *(continued)*



# 16 Troubleshooting

## 1. Before Troubleshooting

The following pages contain troubleshooting tables for use in diagnosing control problems. When using these tables the following should be kept in mind:

- A. This information is only meant to be used by a professional heating technician as an aid in diagnosing boiler problems.
- B. Where applicable, follow all precautions outlined in the Section 11 (Start-up and Checkout) of the boiler installation manual.
- C. In general, these tables assume that there are no loose or miswired electrical connections. Before using these tables inspect all electrical connections on the boiler to make sure that they are tight. Also, check the wiring on the boiler against the wiring diagram in Figures 10-3 and 10-4. Ensure that incoming 120 VAC power polarity is correct and that the boiler is properly grounded. Further, ensure that the control power supply is 24 VAC (minimum 18 VAC to maximum 30 VAC) and polarity is correct.
- D. All controls on this boiler are tested at least once in the manufacturing process and a defective control or component is generally the least likely cause. Before replacing a component, try to rule out all other possible causes.

E. When checking voltage across wiring harness pins be careful not to insert the meter probes into the pins. Doing so may damage the pin, resulting in a loose connection when the harness is reconnected.

## 2. If The Display Is Blank

- A. Check for 24 VAC on transformer secondary connections (pink and brown wires). If voltage across these screws is between 18 and 30 VAC, possible causes include:
  - Loose connection in transformer harness
  - Defective transformer harness
  - Defective boiler control
- B. If voltage is less than 18 VAC at transfer secondary, possible causes include:
  - Service switch off
  - Tripped 120 VAC breaker
  - Miswired or loose connection in 120 VAC boiler circuit.
  - Loose connection between transformer primary and 120 VAC line.
  - Defective transformer (possibly caused by short circuit in 24 VAC wiring or additional loads connected to the transformer in the field).

## 3. If Control Shows *Err* Code

Use Table 16-1 to help identify and correct the cause of the problem.

## 4. If Control Shows *5LR* Code, but Other Problem Present

If no *Err* Code is observed (even after repeatedly pressing **I** to cycle through Operation Mode), use Table 16-2 to help identify and correct the cause of the problem.

# 16 Troubleshooting *(continued)*

**Table 16-1: Error Codes**

| Error Code | Meaning   | Possible Cause  |
|------------|---|---|
| 2          | Pressure Switch failed to open                                | <ul style="list-style-type: none"> <li>Jumped air pressure switch</li> <li>Condensate in air pressure switch or switch tubing</li> <li>Defective air pressure switch</li> </ul>   |
| 4          | Low Flame Signal  | <ul style="list-style-type: none"> <li>Low gas pressure at gas valve inlet</li> <li>Partially plugged pilot tubing or pilot orifice</li> <li>Loose connection in ignition cable or ground wiring</li> <li>Dirty pilot electrode/ground strap</li> <li>Pilot electrode porcelain cracked</li> <li>Damaged pilot hood/ assembly</li> <li>Defective control</li> </ul> |
| 6          | Pilot Flame detected when no flame should be present          | <ul style="list-style-type: none"> <li>Defective gas valve</li> <li>High gas pressure</li> <li>Defective control</li> </ul>   |
| 18         | Internal electronics failure                                  | <ul style="list-style-type: none"> <li>Possible internal problem with boiler control. Cycle power to the boiler and replace control if problem persists.</li> </ul>   |
| 23         | Flame sensed during 30s pre-purge (before pilot valve opened) | <ul style="list-style-type: none"> <li>Defective gas valve</li> <li>High gas pressure</li> <li>Defective control</li> </ul>   |
| 29         | Air pressure switch failed to close                           | <ul style="list-style-type: none"> <li>Vent system blockage</li> <li>Vent system not constructed in accordance with installation manual (excessive length, undersized pipe, wrong terminal, etc)</li> <li>Condensate or leakage in air pressure switch tubing</li> <li>Winds in excess of 40mph</li> </ul>  |
| 32         | Boiler water temperature sensor failure                       | <ul style="list-style-type: none"> <li>Loose sensor connection at control</li> <li>Defective Sensor</li> <li>Defective control</li> </ul>   |
| 35         | Duplicate Zone  | Error code reserved for future use  |
| 57         | Grounded pilot electrode                                      | <ul style="list-style-type: none"> <li>Condensate or foreign material is shorting pilot electrode to ground.</li> <li>Ignition cable insulation is damaged and touching ground.</li> <li>Pilot is damaged</li> </ul>  |
| 58         | AC Power Frequency Error                                      | <ul style="list-style-type: none"> <li>120 VAC power supply frequency is incorrect (Should be 60Hz)</li> <li>120 VAC power supply is dirty (consult electrician and/or Utility)</li> <li>Boiler water temperature sensor common (center wire) is damaged and shorted to ground</li> </ul>   |
| 59         | Line voltage error (Supply voltage too high or low)           | <ul style="list-style-type: none"> <li>Power supply voltage is incorrect (should be 120 VAC nominal)</li> <li>Defective or incorrect 24 VAC transformer</li> <li>Loose 120 VAC connection or 24 VAC connection between transformer and control</li> </ul>   |
| 60         | Thermostat input higher than threshold                        | <ul style="list-style-type: none"> <li>External voltage is applied to thermostat connections (most common cause is external transformer in old thermostat wiring.</li> </ul>  |
| 61         | Line Voltage Unstable   | <ul style="list-style-type: none"> <li>120 VAC power supply is dirty (consult electrician and/or Utility)</li> <li>Loose 120 VAC connection or 24 VAC connection between transformer and control</li> <li>Large electrical loads elsewhere on the installation are switching on and off, causing incoming voltage to swing excessively at boiler.</li> </ul>        |
| 63         | Maximum recycles exceeded                                     | <ul style="list-style-type: none"> <li>See Error Code 4 above (boiler lost proof of pilot 6 times in a row)</li> </ul>  |
| 64         | Internal failure  | <ul style="list-style-type: none"> <li>Improper pilot operation</li> <li>If problem persists, replace control</li> </ul>  |
| 89         | EnviraCom communication lost                                  | Should not be observed on this boiler.  |

# 16 Troubleshooting *(continued)*

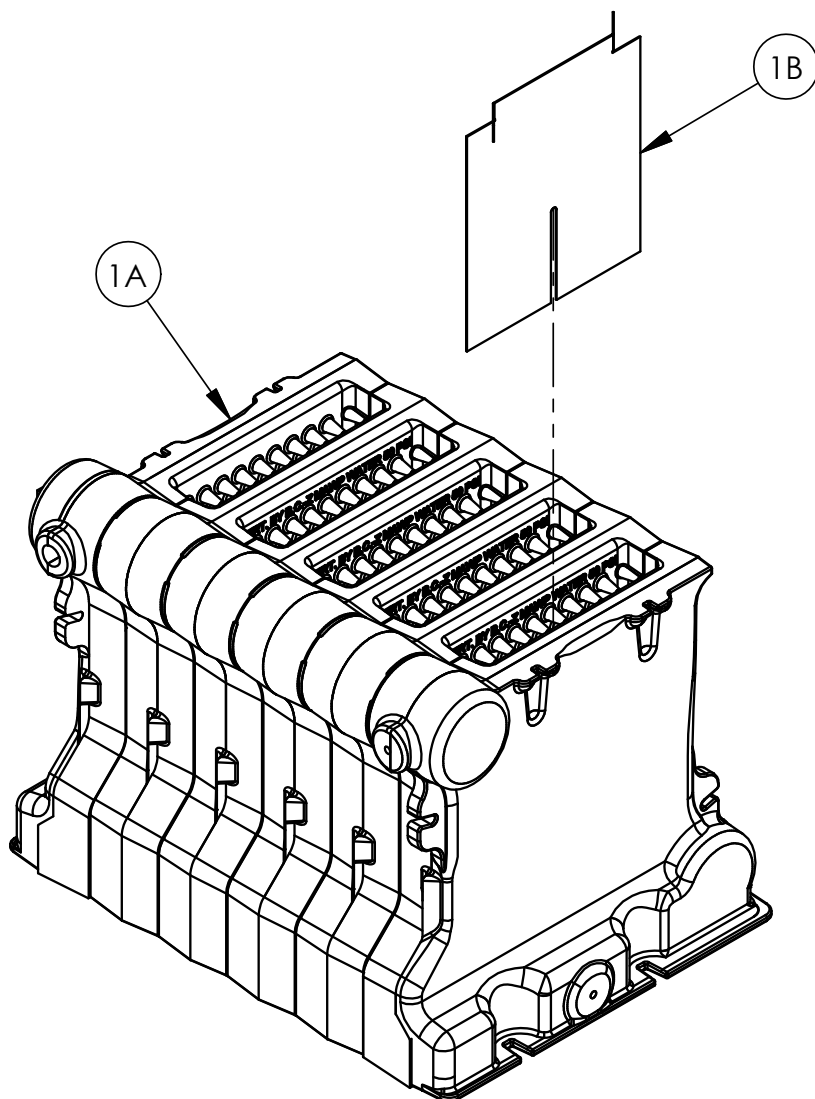
**Table 16-2: Faults Without Error Code Present**

| Displayed Codes           | Problem   | Possible Cause   |
|---------------------------|---|--|
| StA 1<br>Et OFF<br>dh OFF | Burners and Circulator Off  | <ul style="list-style-type: none"> <li>• Thermostat/s not calling for heat</li> <li>• Loose connection in thermostat, zone valve end switch, or zone panel wiring.</li> <li>• Thermostat, zone valve, or zone panel miswired</li> <li>• Defective thermostat, zone valve, or zone panel</li> </ul>   |
| StA 1<br>Et On            | Burners Off<br>Circulator On<br>Boiler Warm                           | <ul style="list-style-type: none"> <li>• Boiler off on high limit (normal operation)</li> <li>• Boiler off on thermal purge (normal operation - See Table 12-7)</li> </ul>   |
| Et On                     | Heating<br>Circulator Off   | <ul style="list-style-type: none"> <li>• Heating Circulator is being forced off on DHW priority (normal operation if Pt=ON - see Table 12-8).</li> <li>• See causes for "DHW Circulator off " below</li> </ul>   |
| dh On                     | DHW<br>Circulator Off   | <ul style="list-style-type: none"> <li>• Loose connection in circulator wiring</li> <li>• Defective circulator</li> <li>• Circulator is running, but system problem is preventing circulation</li> </ul>   |
| StA 15                    | Burners Off<br>and Fan is Off.  | <ul style="list-style-type: none"> <li>• Limit or LWCO connected to auxiliary limit connection is open.</li> <li>• Nothing is connected to auxiliary limit connection and jumper plug is missing.</li> <li>• Flame roll-out switch (FRS) open due to blocked heat exchanger. Correct problem and replace FRS with exact replacement (see parts list)</li> </ul>  |
| StA 6                     | No spark at pilot   | <ul style="list-style-type: none"> <li>• Loose connection in ignition cable or pilot ground</li> <li>• Damaged electrode porcelain or ignition wire insulation (replace pilot)</li> <li>• Pilot electrode or Ground strap damaged (replace pilot)</li> <li>• If you cannot hear spark at all, replace control</li> </ul>   |
| StA 6                     | Spark, but no pilot flame   | <ul style="list-style-type: none"> <li>• Low inlet gas pressure</li> <li>• Plugged, kinked, or leaking pilot tubing</li> <li>• Plugged pilot orifice</li> <li>• Gas line not purged of air</li> <li>• Defective pilot assembly</li> <li>• Defective gas valve (before replacing, confirm that there is 24 VAC between PV and MV/ PV. If there is not, control harness is loose or the control itself is defective).</li> <li>• Loose connection in harness between control and gas valve.</li> </ul> |
| StA 6                     | Pilot flame present, but spark does not shut off                      | <ul style="list-style-type: none"> <li>• Low inlet gas pressure</li> <li>• Partially plugged, kinked, or leaking pilot tubing</li> <li>• Partially plugged pilot orifice</li> <li>• Loose connection in ignition cable or pilot ground</li> <li>• Damaged electrode porcelain or ignition wire insulation (replace pilot)</li> <li>• Pilot electrode or Ground strap damaged (replace pilot)</li> <li>• Defective Control</li> </ul>   |
| StA 8                     | Pilot flame present, spark off, but Main Burner does not light at all | <ul style="list-style-type: none"> <li>• Loose connection in harness between control and gas valve</li> <li>• Defective gas valve (before replacing, confirm that there is 24 VAC between MV and MV/ PV. If there is not either there is a loose connection in the control harness or the control itself is defective).</li> </ul>   |
| StA 10                    | Main burner lights, but shuts off immediately                         | <ul style="list-style-type: none"> <li>• Low inlet gas pressure</li> <li>• Partially plugged, kinked, or leaking pilot tubing</li> <li>• Partially plugged pilot orifice</li> </ul>  |
| StA 10<br>or StA 13       | No spark or pilot   | <ul style="list-style-type: none"> <li>• Pilot was either never established or proof of pilot was lost after it was lit. Cycle power to the boiler and look for symptoms above.</li> </ul>   |

## 17 Service Parts

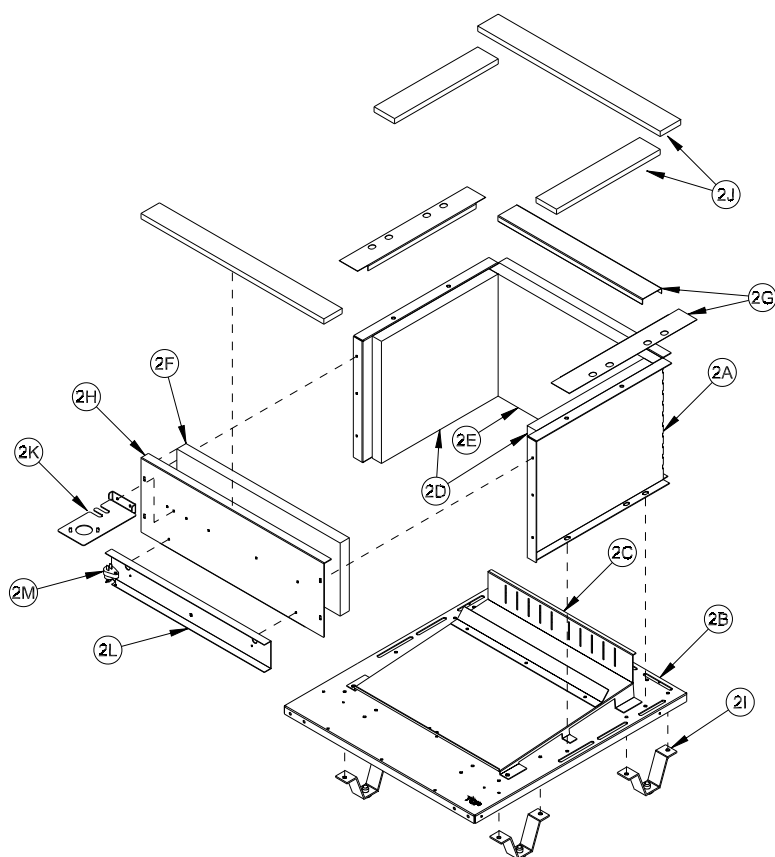
All service parts may be obtained through your local Velocity Boiler Works wholesale distributor. Should you require assistance in locating a Velocity Boiler Works distributor in your area, or you have questions regarding the availability of products or service parts, please contact us at (215) 535-8900 or Fax (215) 535-9736 or at [www.velocityboilerworks.com](http://www.velocityboilerworks.com).

Main burner orifice and pressure switches shown are for sea level configured boilers. For boilers installed at elevations above 2,000 ft., consult the local Velocity Boiler Works representative or the factory for the correct main burner orifice.



| Key | Description                     | Part Number [Quantity] |               |               |               |               |               |
|-----|---------------------------------|------------------------|---------------|---------------|---------------|---------------|---------------|
|     |                                 | 3 Section              | 4 Section     | 5 Section     | 6 Section     | 7 Section     | 8 Section     |
| 1A  | Section Assembly                | 109607-03 [1]          | 109607-04 [1] | 109607-05 [1] | 109607-06 [1] | 109607-07 [1] | 109607-08 [1] |
| 1B  | Flue Baffle (4 Baffles per Kit) | 110400-01 [1]          | 110400-01 [1] | 110400-01 [1] | 110400-01 [2] | 110400-01 [2] | 110400-01 [2] |

# 17 Service Parts *(continued)*

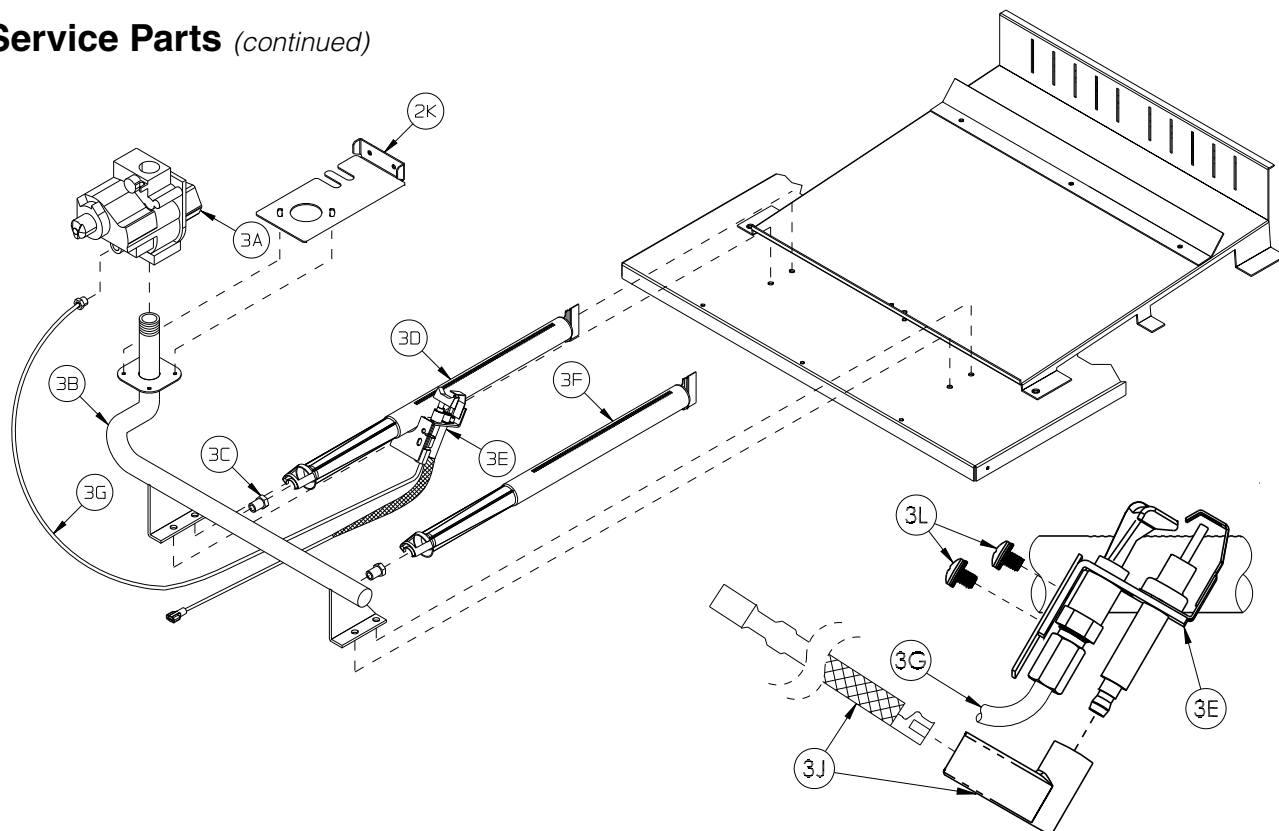


## ⚠ WARNING

If base must be replaced, there is a good chance pilot assembly and pilot tubing will need to be replaced as well. Replacement pilot assemblies are shown on page 57. Also check condition of manifold and gas valve and replace if they show any signs of heat, corrosion, or water damage.

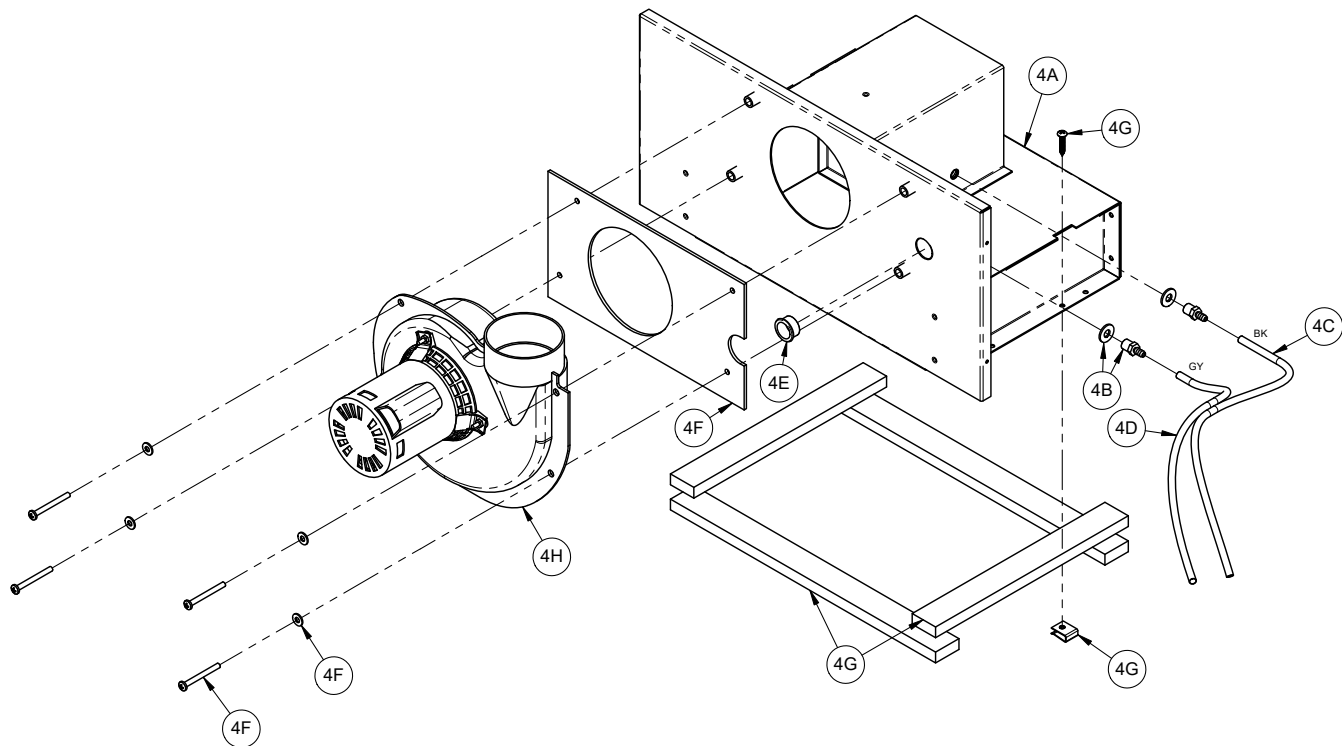
| Key No. | Description                          | Part Number [Quantity] |               |               |               |               |               |
|---------|--------------------------------------|------------------------|---------------|---------------|---------------|---------------|---------------|
|         |                                      | 3 Section              | 4 Section     | 5 Section     | 6 Section     | 7 Section     | 8 Section     |
| 2A      | Base Wrapper                         |                        |               |               |               |               |               |
| 2B      | Base Tray                            |                        |               |               |               |               |               |
| 2C      | Burner Tray Assembly                 |                        |               |               |               |               |               |
| 2D      | Base Side Insulation                 |                        |               |               |               |               |               |
| 2E      | Base Rear Insulation                 |                        |               |               |               |               |               |
| 2F      | Base Front Insulation                |                        |               |               |               |               |               |
| 2G      | Drip Shields                         |                        |               |               |               |               |               |
| 2H      | Base Front Panel                     |                        |               |               |               |               |               |
| 2I      | Base Leg Assembly                    | 110401-03 [1]          | 110401-04 [1] | 110401-05 [1] | 110401-06 [1] | 110401-07 [1] | 110401-08 [1] |
| 2J      | Base Gasket Kit                      |                        |               |               |               |               |               |
| 2K      | Manifold Support Bracket             |                        |               |               |               |               |               |
| 2L      | Burner Access Panel                  |                        |               |               |               |               |               |
| 2M      | Flame Rollout Switch                 |                        |               |               |               |               |               |
| 3B      | Gas Manifold                         |                        |               |               |               |               |               |
| 3D      | Main Burner with Pilot Bracket       |                        |               |               |               |               |               |
| 3G      | Pilot Tubing (1/8 in. OD x 36 in.)   |                        |               |               |               |               |               |
| 3F      | Main Burners less Pilot Bracket      |                        |               |               |               |               |               |
| 4G      | Canopy Gasket & Hardware             |                        |               |               |               |               |               |
| 2J      | Base Gasket Kit                      | 6206002 [1]            |               |               |               |               |               |
| 2L      | Burner Access Panel                  | 110403-03 [1]          | 110403-04 [1] | 110403-05 [1] | 110403-06 [1] | 110403-07 [1] | 110403-08 [1] |
| 2M      | Flame Rollout Switch<br>G4AM0600240C | 109616-01 [1]          |               |               |               |               |               |

# 17 Service Parts *(continued)*



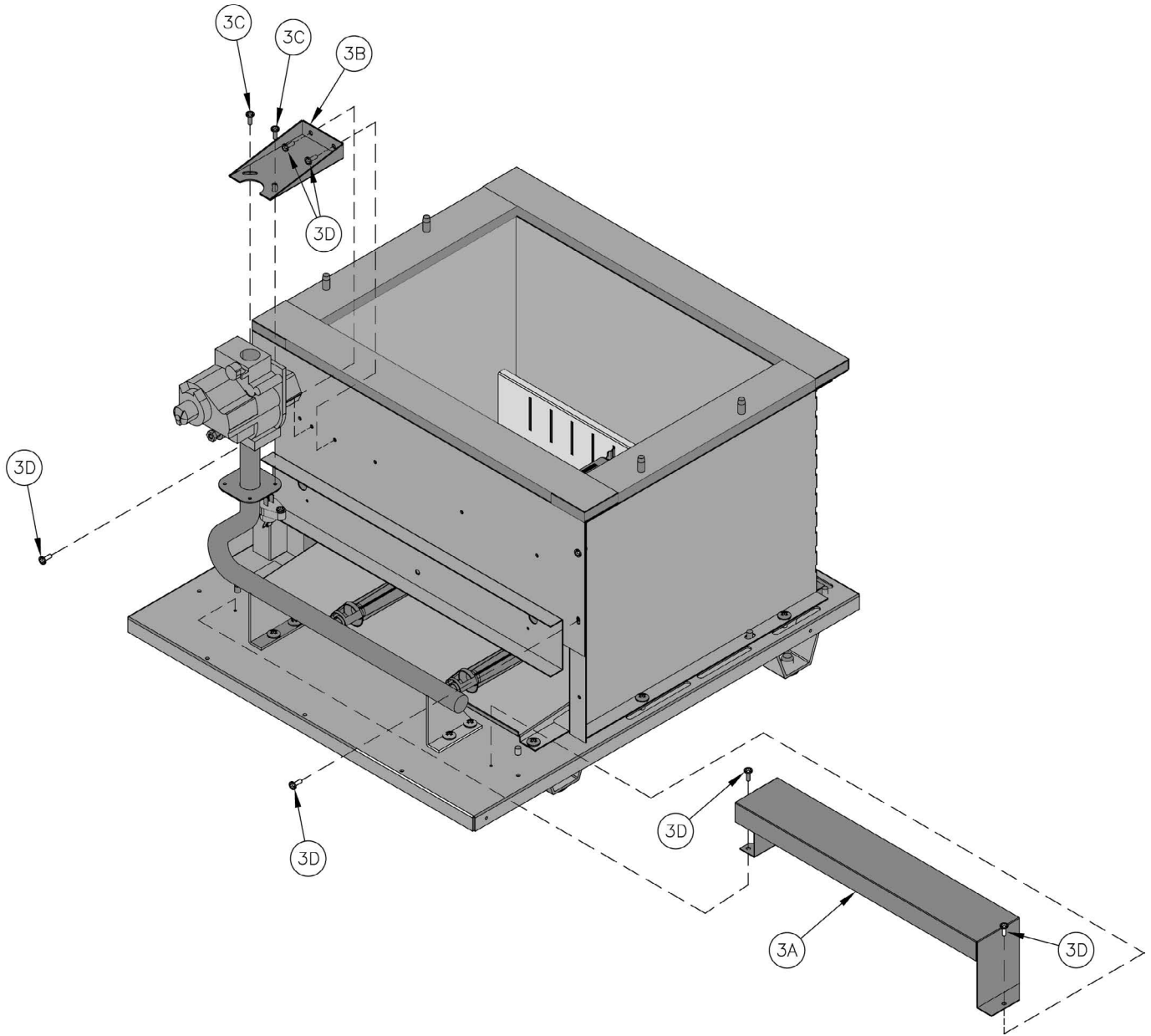
| Key No. | Description   | Part Number [Quantity]                       |               |               |               |               |               |
|---------|---|--|---------------|---------------|---------------|---------------|---------------|
|         |   | 3 Section                                    | 4 Section     | 5 Section     | 6 Section     | 7 Section     | 8 Section     |
| 3A      | Gas Valve (Natural Gas), VR8204C6000                      | 110404-01 [1]                                |               |               |               | N/A           |               |
|         | Gas Valve (Natural Gas), VR8304P4553                      | N/A  |               |               |               | 110405-01 [1] |               |
|         | Gas Valve (LP Gas), VR8204C6018                           | 110406-01 [1]                                |               |               |               | N/A           |               |
|         | Gas Valve (LP Gas), VR8304P4280                           | N/A  |               |               |               | 110407-01 [1] |               |
| 3B      | Gas Manifold  | 109731-03 [1]                                | 109731-04 [1] | 109731-05 [1] | 109731-06 [1] | 109731-07 [1] | 109731-08 [1] |
| 3C      | #48 Gas Orifice (Natural Gas, Sea Level - 2,000 ft.)      | 110408-01 [1]                                |               |               |               |               |               |
|         | #56 Gas Orifice (LP Gas, Sea Level - 2,000 ft.)           | 110409-01 [1]                                |               |               |               |               |               |
|         | #49 Gas Orifice (Natural Gas, 2,001 - 10,200 ft.)         | 110618-01 [1]                                |               |               |               |               |               |
|         | #57 Gas Orifice (LP Gas, 2,001 - 10,200 ft.)              | 110619-01 [1]                                |               |               |               |               |               |
| 3D      | Pilot Burner  | 109629-01 [1]                                |               |               |               |               |               |
| 3E      | Pilot Assembly - (Natural Gas) Honeywell Q345A2369        | 110410-01 [1]                                |               |               |               |               |               |
|         | Pilot Assembly - (LP Gas) Honeywell Q3481B1511            | 110620-01 [1]                                |               |               |               |               |               |
| 3F      | Main Burner [3 Burners per kit]                           | 109628-01 [1]                                | 109628-01 [2] | 109628-01 [3] | 109628-01 [3] | 109628-01 [4] | 109628-01 [5] |
| 3G      | Pilot Tubing (1/8 in. OD x 36 in.)                        | 110412-01 [1]                                |               |               |               |               |               |
| 3J      | Ignition Cable & Boot                                     | Available with 3D                            |               |               |               |               |               |
| 3L      | Machine Screw, 10-32 x 1/4 in. with External Tooth Washer | Obtain Locally (Natural Gas [2], LP Gas [1]) |               |               |               |               |               |

# 17 Service Parts *(continued)*



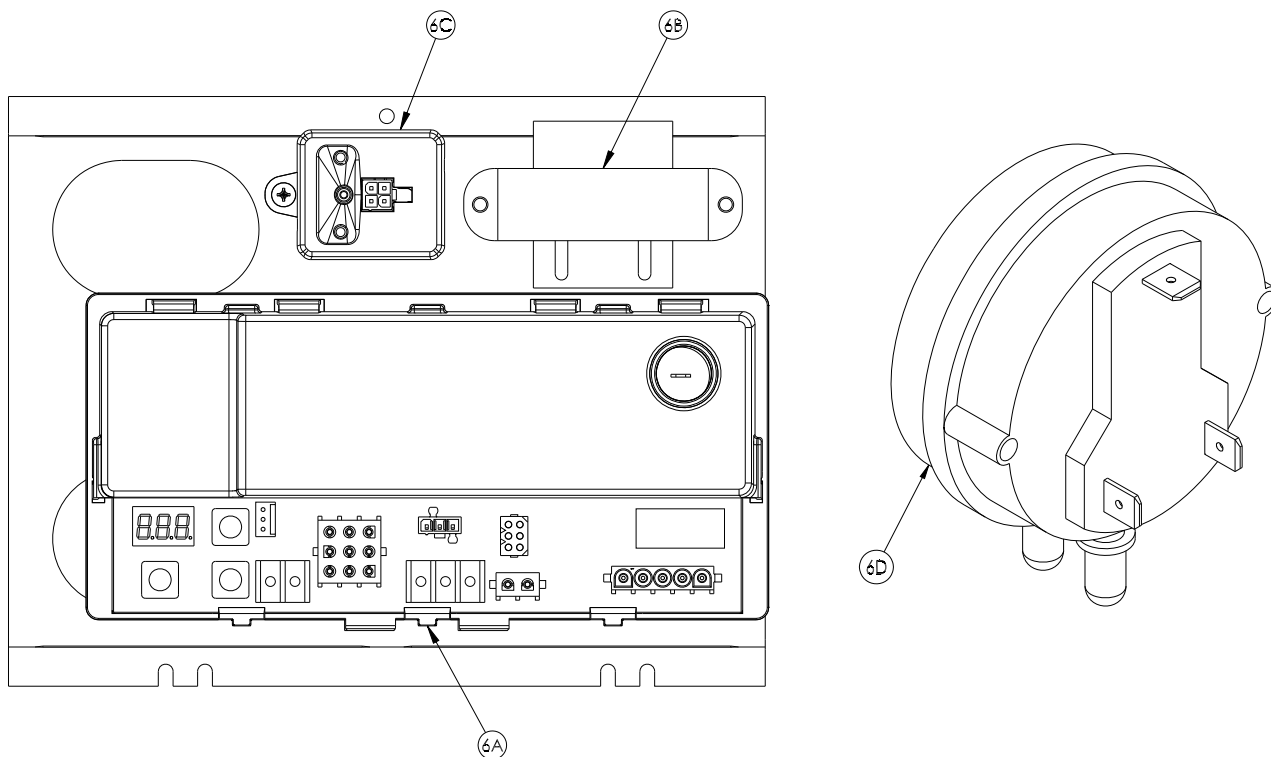
| Key No. | Description                            | Part Number [Quantity] |                  |                  |                  |                  |                  |
|---------|--|------------------------|------------------|------------------|------------------|------------------|------------------|
|         |  | 3 Section              | 4 Section        | 5 Section        | 6 Section        | 7 Section        | 8 Section        |
| 4A      | Canopy                                 |                        |                  |                  |                  |                  |                  |
| 4B      | Static Pressure Hose Barb (Dwyer A309) |                        |                  |                  |                  |                  |                  |
| 4C      | Pressure Switch Tubing, Black          |                        |                  |                  |                  |                  |                  |
| 4D      | Pressure Switch Tubing, Gray           | 110413-03<br>[1]       | 110413-04<br>[1] | 110413-05<br>[1] | 110413-06<br>[1] | 110413-07<br>[1] | 110413-08<br>[1] |
| 4E      | Bushing                                |                        |                  |                  |                  |                  |                  |
| 4F      | Fan Gasket & Fan Hardware              |                        |                  |                  |                  |                  |                  |
| 4G      | Canopy Gasket & Hardware               |                        |                  |                  |                  |                  |                  |
| 4G      | Canopy Gasket & Hardware               |                        |                  | 6206001          | [1]              |                  |                  |
| 4H      | Fan Kit (includes Fan and 4F)          |                        |                  | 110089-01        | [1]              |                  |                  |
| 4F      | Fan Gasket & Fan Hardware              |                        |                  | 110414-01        | [1]              |                  |                  |

# 17 Service Parts *(continued)*



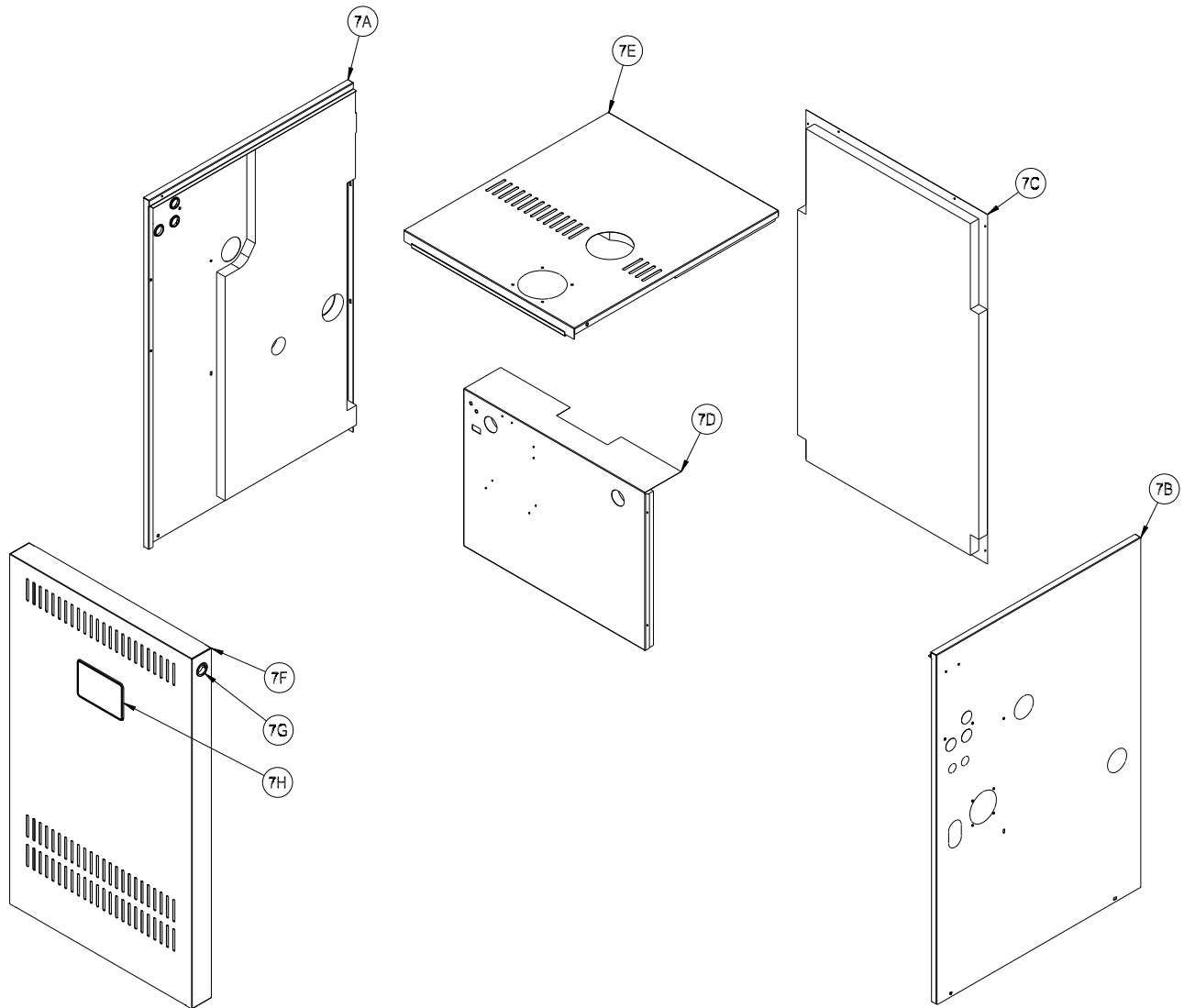
| Key No. | Description                     | Part Number [Quantity] |               |               |               |               |               |
|---------|---------------------------------|------------------------|---------------|---------------|---------------|---------------|---------------|
|         |                                 | 3 Section              | 4 Section     | 5 Section     | 6 Section     | 7 Section     | 8 Section     |
| 5A      | Burner Cover (Natural Gas Only) | 110402-03 [1]          | 110402-04 [1] | 110402-05 [1] | 110402-06 [1] | 110402-07 [1] | 110402-08 [1] |

# 17 Service Parts *(continued)*



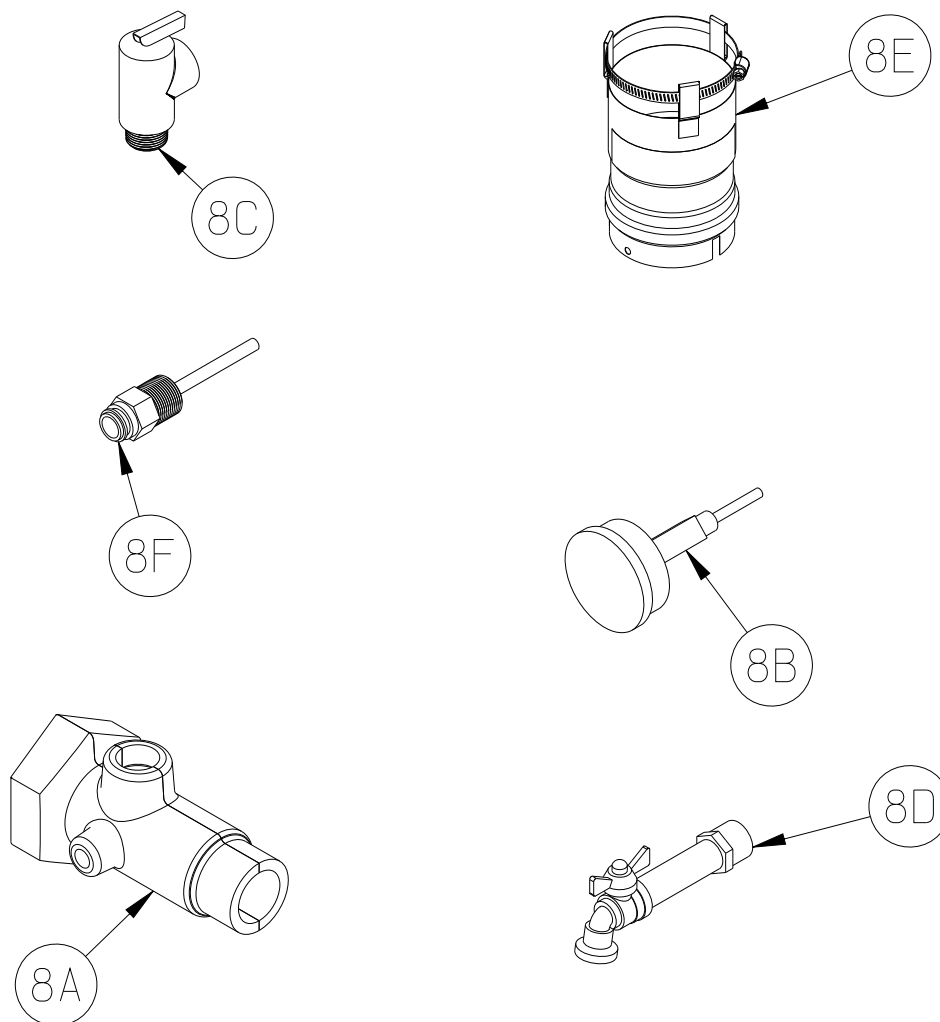
| Key No.    | Description   | Part Number [Quantity] |           |           |           |           |           |
|------------|---|------------------------|-----------|-----------|-----------|-----------|-----------|
|            |   | 3 Section              | 4 Section | 5 Section | 6 Section | 7 Section | 8 Section |
| 6A         | Integrated Boiler Control                               | 103968-02 [1]          |           |           |           |           |           |
| 6B         | Transformer   | 106034-01 [1]          |           |           |           |           |           |
| 6C         | Hydrolevel IDL 1200 LWCO Kit                            | 106495-02 [1]          |           |           |           |           |           |
| 4C, 4D, 6D | Air Pressure Switch w/ Tubing (Sea Level to 2,000 ft.)  | 110415-01 [1]          |           |           |           |           |           |
| 4C, 4D, 6D | Air Pressure Switch w/ Tubing (2,001 ft. to 10,200 ft.) | 110416-01 [1]          |           |           |           |           |           |
| 4C, 4D     | APS Tubing Kit  | 110417-01 [1]          |           |           |           |           |           |

# 17 Service Parts *(continued)*



| Key No. | Description            | Part Number [Quantity] |               |               |               |               |               |
|---------|------------------------|------------------------|---------------|---------------|---------------|---------------|---------------|
|         |                        | 3 Section              | 4 Section     | 5 Section     | 6 Section     | 7 Section     | 8 Section     |
| 7A      | Left Jacket Panel      | 113345-01 [1]          |               |               |               |               |               |
| 7B      | Right Jacket Panel     |                        |               |               |               |               |               |
| 7C      | Rear Jacket Panel      | 113346-03 [1]          | 113346-03 [1] | 113346-05 [1] | 113346-06 [1] | 113346-07 [1] | 113346-08 [1] |
| 7D      | Vestibule Jacket Panel |                        |               |               |               |               |               |
| 7E      | Top Jacket Panel       |                        |               |               |               |               |               |
| 7F      | Door                   |                        |               |               |               |               |               |
| 7G      | Finger Bushing         |                        |               |               |               |               |               |
| 7H      | Logo Plate             |                        |               |               |               |               |               |

# 17 Service Parts *(continued)*



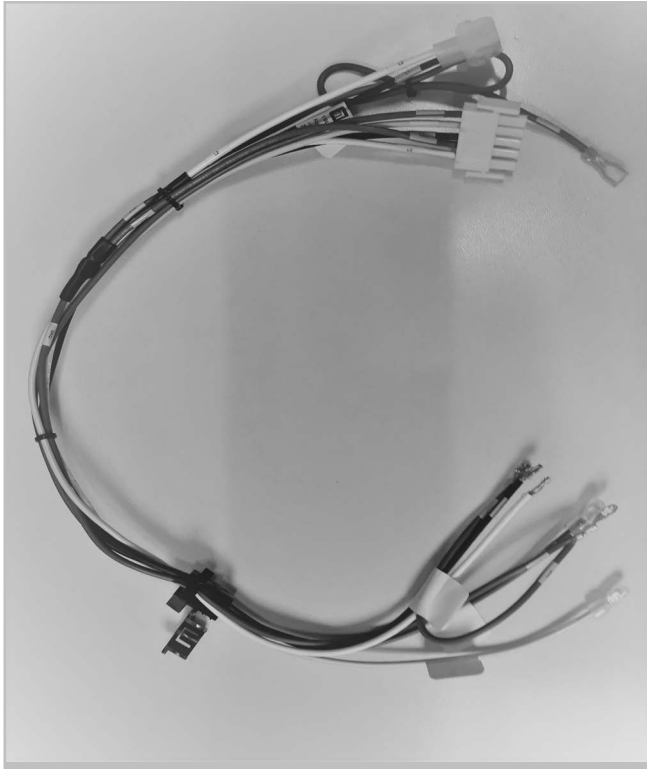
| Key No. | Description                                   | Part Number [Quantity]                         |           |           |           |           |               |
|---------|---|--|-----------|-----------|-----------|-----------|---------------|
|         |   | 3 Section                                      | 4 Section | 5 Section | 6 Section | 7 Section | 8 Section     |
| 8A      | Water Manifold                                | 109614-01 [1]                                  |           |           |           |           |               |
| 8B      | Temperature/Pressure Gauge                    | 105894-01 [1]                                  |           |           |           |           |               |
| 8C      | 3/4 in. Safety Relief Valve (30 psi)          | 109038-01 [1]                                  |           |           |           |           |               |
| 8D      | Boiler Drain Valve                            | Obtain Locally (3/4 in. NPT boiler connection) |           |           |           |           |               |
| 8E      | Vent Adapter, 3 in.                           | 109883-01 [1]                                  |           |           |           |           | N/A           |
| 8E      | Vent Adapter, 4 in.                           | N/A  |           |           |           |           | 109885-01 [1] |
| 8F      | 1/2 in. Short Electrowell (Hydrolevel 48-221) | 110422-01 [1]                                  |           |           |           |           |               |

## WARNING

Use of a control well other than that shown above may render the low water cut-off feature on this boiler inoperative.

# 17 Service Parts *(continued)*

9A



9B



| Key No. | Description               | Part Number [Quantity] |           |           |           |           |           |
|---------|---------------------------|------------------------|-----------|-----------|-----------|-----------|-----------|
|         |                           | 3 Section              | 4 Section | 5 Section | 6 Section | 7 Section | 8 Section |
| 9A      | Line Voltage Wire Harness | 110423-01 [1]          |           |           |           |           |           |
| 9B      | Low Voltage Wire Harness  |                        |           |           |           |           |           |

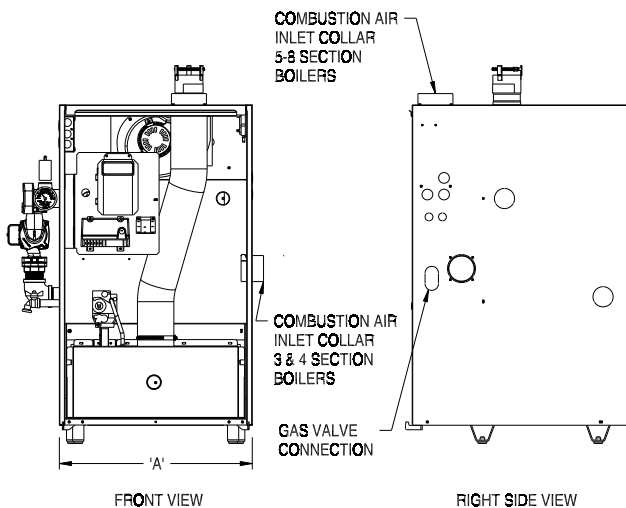
**Gas Conversion Kits:**

| Key No.   | Description                          | Part Number [Quantity] |           |           |           |               |           |
|-----------|--------------------------------------|------------------------|-----------|-----------|-----------|---------------|-----------|
|           |                                      | 3 Section              | 4 Section | 5 Section | 6 Section | 7 Section     | 8 Section |
| Not Shown | Natural Gas to LP (0-2,000 ft.)      | 110858-01 [1]          |           |           |           | 110860-01 [1] |           |
| Not Shown | Natural Gas to LP (2,000-10,000 ft.) | 110859-01 [1]          |           |           |           | 110861-01 [1] |           |
| Not Shown | LP to Natural Gas (0-2,000 ft.)      | 110862-01 [1]          |           |           |           | 110864-01 [1] |           |
| Not Shown | LP to Natural Gas (2,000-10,000 ft.) | 110863-01 [1]          |           |           |           | 110865-01 [1] |           |

## Appendix A Direct Vent Installations

This Appendix describes how to bring combustion air directly from outside to the boiler (direct venting) using the Direct Vent Conversion Kits shown in Table 3-3. These kits includes an air box and other components needed to route air directly to the combustion chamber, as well as an air intake terminal for horizontal installations. By using these kits to route combustion air directly to the boiler, the need to obtain such air from within the structure is eliminated. This is often advantageous in tightly constructed buildings.

Figure A-1 shows the boiler with the Direct Vent Conversion Kit installed and the location of the air inlet connection.



**Figure A-1: Boiler With Direct Vent Conversion Kit Installed (Front Door Omitted for Clarity)**

Table A-2 Summarizes all direct vent options. One of the columns in Table A-2 must describe the planned direct vent system exactly. In addition, observe the following guidelines:

1. Direct Vent Conversion Kit Installation on the Boiler - Follow the instructions provided with the kit to install the Direct Vent Conversion Kit on the boiler.

### **⚠ WARNING**

Failure to install the intake box and other components on the boiler as described in the Direct Vent Conversion Kit instructions could cause the boiler to operate at elevated Carbon monoxide (CO) levels resulting in personal injury or loss of life.

2. Vent System Design and Assembly - Vent system is assembled using installer supplied AL29-4C stainless steel vent components. See Section 7 for detailed instructions on vent system design and assembly. Exception: In some cases, clearances from vent terminals are different when the boiler is direct vented. See "Horizontal Terminal Location" in this section.

### 3. Intake System Design -

- A. Intake Piping Materials - Any of the following materials may be used between the intake collar on the boiler and the intake terminal:

- 26 gauge galvanized vent pipe.
- Schedule 20 or 40 PVC

- B. Intake Piping Sizes and Maximum Lengths - Maximum intake lengths and intake pipe nominal diameters are shown in Table A-2. For each elbow used on the intake system, reduce the maximum allowable length by the amount shown in Table A-8. Note that no reduction is made for the intake terminal.

Example:

*A 3 in. air intake system is planned for a horizontal direct vented 105,000 BTU/hr boiler which has the following galvanized components:*

- 2 ft. vertical pipe*
- 1 90 elbow*
- 5 ft. horizontal pipe*
- 1 90 elbow*
- 3 ft. horizontal pipe*
- 1 termination fitting*

*The Vent Option #5 column in Table A-2 describes a horizontal direct vent system using 3 in. intake pipe. From this column, we see that this boiler may have an intake piping system of up to 60 ft. From Table A.8 the equivalent length of the 3 in 90 degree galvanized elbow is 5.5 ft. The maximum allowable run of straight pipe on this system is therefore:*

$$60 \text{ ft.} - 5.5 \text{ ft.} - 5.5 \text{ ft.} = 49 \text{ ft.}$$

*Since the planned installation has only 10 ft. of straight pipe, the planned intake length is acceptable.*

# Appendix A Direct Vent Installations *(continued)*

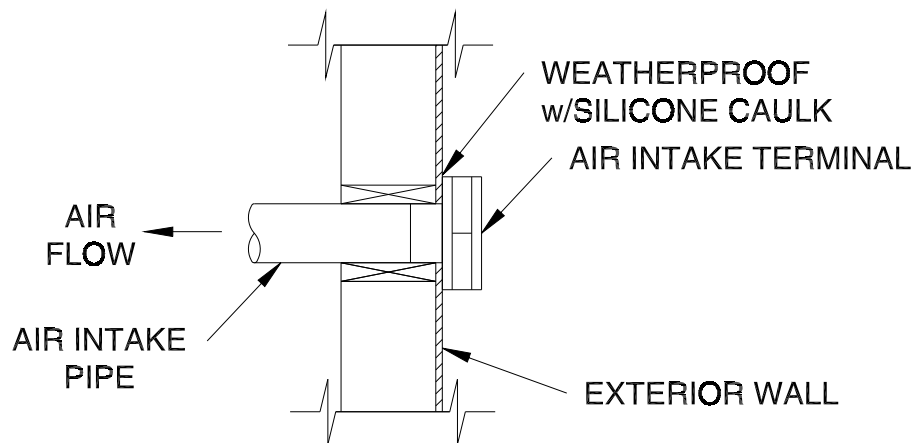
**Table A-2: Summary Of Direct Vent Options**  
(See Section 7 for Additional Details on Vent System Installation)

| Classification Used in this Manual |               | Horizontal Direct Vent   |                                |                         | Vertical Direct Vent    |                         |                         |
|------------------------------------|---------------|--|--------------------------------|-------------------------|-------------------------|-------------------------|-------------------------|
| Vent Option #                      |               | 5  | 6                              | 7                       | 8                       | 9                       | 10                      |
| Illustrated in Figure              |               | A.3, A.4   | A.3, A.4                       | A.3, A.4                | A.6, A.7                | A.6, A.7                | A.6, A.7                |
| Structure Penetration              | Vent          | Wall   | Wall                           | Wall                    | Roof                    | Roof                    | Roof                    |
|                                    | Intake        | Wall   | Wall                           | Wall                    | Roof                    | Roof                    | Roof                    |
| Material                           | Vent          | Listed AL29-4C Stainless Special Gas Vent System (See Boiler Manual) |                                |                         |                         |                         |                         |
|                                    | Intake        | 26 Gauge Galvanized Pipe or PVC                                      |                                |                         |                         |                         |                         |
| Nominal Diameter                   | Vent          | 3 in.  | 3 in.                          | 4 in.                   | 3 in.                   | 3 in.                   | 4 in.                   |
|                                    | Intake        | 3 in.  | 4 in.                          | 4 in.                   | 3 in.                   | 4 in.                   | 4 in.                   |
| Maximum Vent Length                | 3 & 4 Section | 50 ft.   | Not Permitted                  | Not Permitted           | 50 ft.                  | Not Permitted           | Not Permitted           |
|                                    | 5 & 6 Section | Not Permitted  | 50 ft.                         | Not Permitted           | Not Permitted           | 50 ft.                  | Not Permitted           |
|                                    | 7 Section     | Not Permitted  | 15 ft.                         | 50 ft.                  | Not Permitted           | 15 ft.                  | 50 ft.                  |
|                                    | 8 Section     | Not Permitted  | Not Permitted                  | 40 ft.                  | Not Permitted           | Not Permitted           | 40 ft.                  |
| Maximum Intake Length              | 3 & 4 Section | 60 ft.   | Not Permitted                  | Not Permitted           | 60 ft.                  | Not Permitted           | Not Permitted           |
|                                    | 5 & 6 Section | Not Permitted  | 50 ft.                         | Not Permitted           | Not Permitted           | 50 ft.                  | Not Permitted           |
|                                    | 7 Section     | Not Permitted  | 25 ft.                         | 50 ft.                  | Not Permitted           | 25 ft.                  | 50 ft.                  |
|                                    | 8 Section     | Not Permitted  | Not Permitted                  | 40 ft.                  | Not Permitted           | Not Permitted           | 40 ft.                  |
| Terminal Option A                  | Vent          | 3 in. Tee <sup>1</sup>   | 3 in. Tee <sup>1</sup>         | 4 in. Tee <sup>1</sup>  | 3 in. Cap <sup>1</sup>  | 3 in. Cap <sup>1</sup>  | 4 in. Cap <sup>1</sup>  |
|                                    | Intake        | 3 in. Disk <sup>2</sup>  | 4 in. Disk <sup>2</sup>        | 4 in. Disk <sup>2</sup> | 3 in. 180° El           | 4 in. 180° El           | 4 in. 180° El           |
| Terminal Option B                  | Vent          | Miter + 45° Elbow <sup>3</sup>                                       | Miter + 45° Elbow <sup>3</sup> | Not Permitted           | 3 in. Cap <sup>1</sup>  | 3 in. Cap <sup>1</sup>  | 4 in. Cap <sup>1</sup>  |
|                                    | Intake        | 3 in. Disk <sup>2</sup>  | 4 in. Disk <sup>2</sup>        |                         | 3 in. Disk <sup>2</sup> | 4 in. Disk <sup>2</sup> | 4 in. Disk <sup>2</sup> |

1. Tee or Cap terminal is supplied by the installer and is compatible with special gas vent system. See Table 7-7 for details.

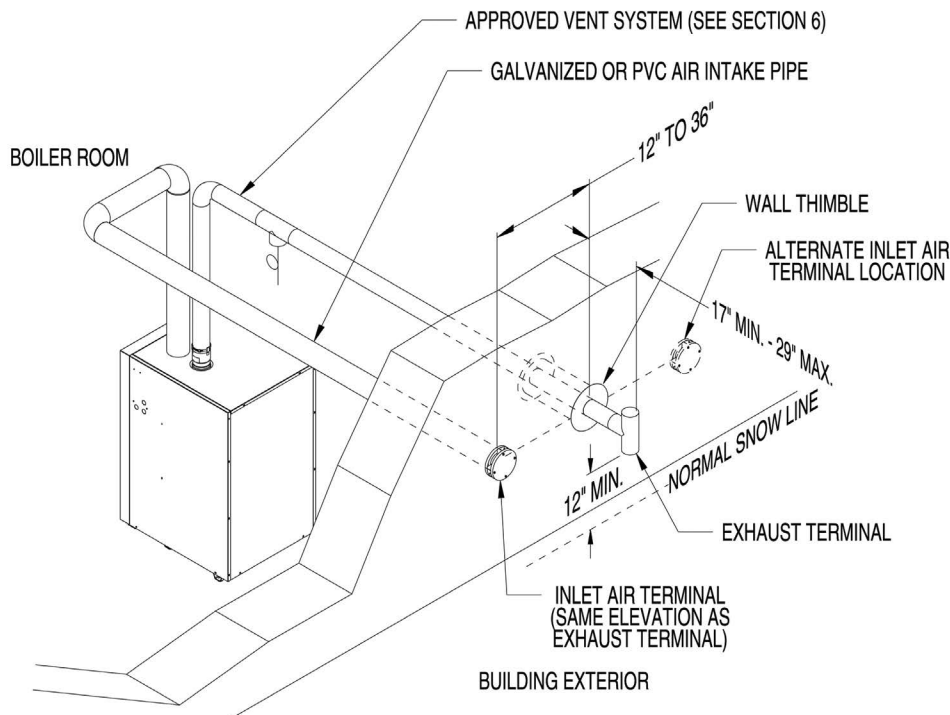
2. Disk Terminal is included with Direct Vent Conversion Kit.

3. Suitable for use on 3 section thru 6 section only. Miter terminal is part #8110701 and is purchased separately. 45° Elbow is by special gas vent manufacturer.



**Figure A-3: Horizontal Installation of Air Intake Terminal**

## Appendix A Direct Vent Installations *(continued)*



**Figure A-4: Horizontal Direct Venting (Vent Options 5, 6)**

### C. Permitted Intake Terminals –

- i. Horizontal venting applications use the terminal provided with the Direct Vent Conversion Kit. Install this terminal so that it is flush with the wall as shown in Figure A-3. Seal the terminal to the wall using silicone caulk.
- ii. Vertical systems use either the terminal provided with this kit or a 180 degree elbow (either a single fitting or two 90 degree elbows) as shown in Figure A-6 or A-7. Note that the 180 elbow is preferred if the intake terminal is frequently exposed to wind-driven rain. Except in very cold climates where ice build-up is a concern, it is recommended that a rodent screen be installed in the end of the 180 degree elbow. When this is done, use stainless steel, galvanized steel, or non-metallic screen having  $\frac{1}{2}$  in. mesh.

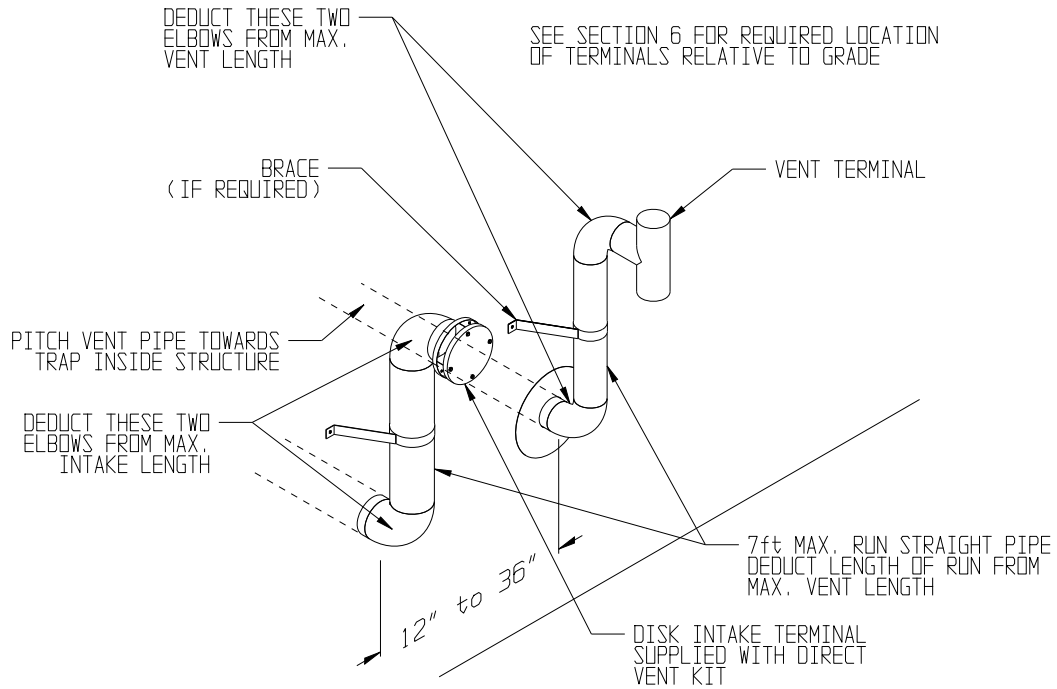
D. Horizontal terminal location – Install the intake terminal to either side of the exhaust terminal as shown in Figure A-4. The intake terminal must be on the same wall as the exhaust terminal. Maintain at least 12 in. from the intake terminal to the exhaust terminal as shown. Also note that when this kit is used, the exhaust terminal must be at least 1 foot from any door, window, or gravity inlet into the building. This is less than the 4 ft. clearance shown in Section 6 for boilers using indoor combustion air.

E. Vertical terminal location - Install the intake terminal as shown in Figure A-6 or A-7. The vertical distance between vent and air inlet terminal openings must be at least 12 in. The bottom of the air inlet terminal must be at least 12 in. above the normal snow accumulation that can be expected on the roof.

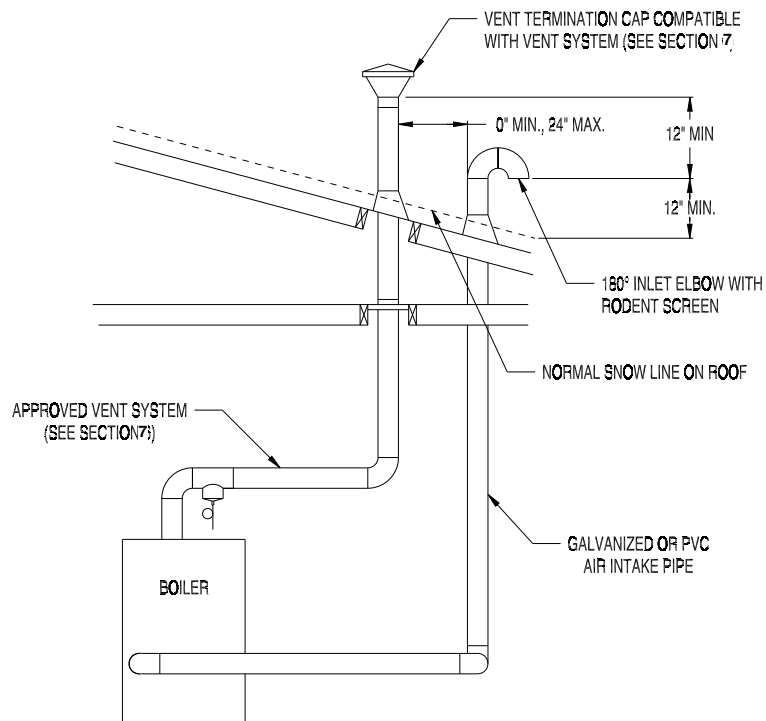
F. Terminal Offsets – When horizontal terminals are offset as shown in Figure A-5, both must be offset vertically by the same distance.

G. Support of Intake Piping – Support intake piping every 5 feet.

# Appendix A Direct Vent Installations *(continued)*



**Figure A-5: Horizontal Terminal Offsets**

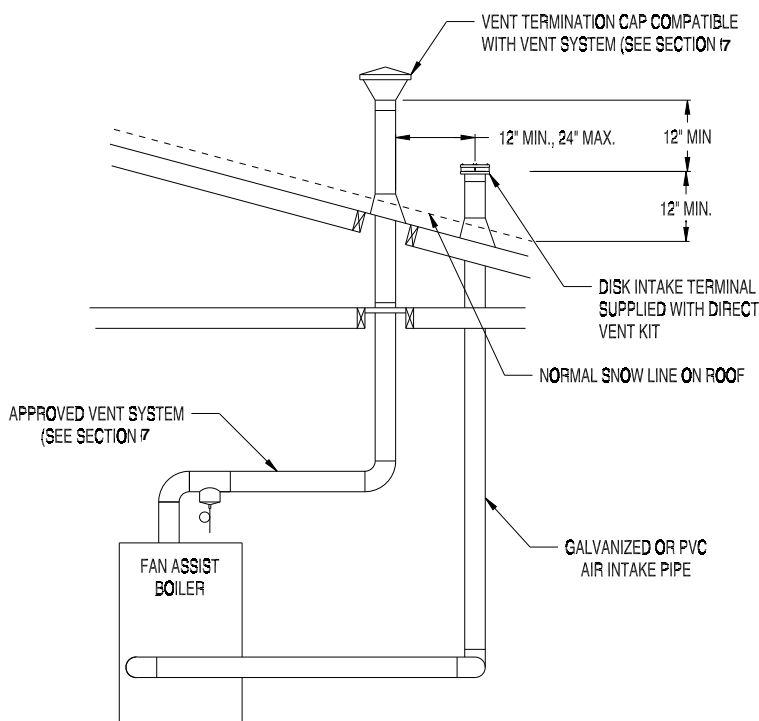


**Figure A-6: Vertical Direct Vent System (Vent Options 7, 8)**

## Appendix A Direct Vent Installations *(continued)*

### 4. Air Intake System Assembly -

- A. If PVC piping is used, use PVC cement to assemble the PVC intake system components.
- B. If metallic “smoke pipe” is used, use at least three sheet metal screws per joint. Seal the outside of all joints.
- C. The male end of metallic “smoke pipe” will fit inside the air inlet collar on the boiler. Secure with a single sheet metal screw and seal the outside of the joint with silicone sealant.
- D. If PVC is used for the intake system, the PVC will fit over the outside of the air intake collar on the boiler. Secure the PVC pipe directly to the boiler using a single sheet metal screw and seal the outside of the joint with silicone sealant.
- E. Two 90-degree elbows may be used to make the 180-degree air intake termination elbow used on vertical direct vent installations.



**Figure A-7: Vertical Direct Vent System Using Disk Intake Terminal (Vent Options 7, 8)**

**Table A-8: Equivalent Lengths for Air Intake Fittings  
(See Section 6 for Vent Fitting Equivalent Lengths)**

| FITTING                       | EQUIVALENT LENGTH (ft.) |       |
|-------------------------------|-------------------------|-------|
|                               | 3 in.                   | 4 in. |
| Short Radius PVC 90° Elbow    | 10.0                    | 13.0  |
| Long Sweep/Sanitary 90° Elbow | 4.0                     | 9.0   |
| 5 Pc. Galvanized 90° Elbow    | 5.5                     | 8.0   |
| PVC or Galvanized 45° Elbow   | 3.0                     | 4.5   |

## Appendix B: Instructions for High Altitude Installations (US Only)

These instructions apply only to the following altitude ranges: **Sea Level - 2,000 ft., 2,001-10,200 ft.** These instructions contain specific information to setup your boiler to ensure proper operation.

As with most gas appliances, special consideration must be given to when this boiler is installed at altitudes above 2,000 ft. In the case of this boiler, there are three basic differences between the sea level and high altitude configurations:

- Smaller main burner orifice are used – This results in an input reduction of approximately 3.3% -per 1,000 ft. for natural gas and 2.8% per 1,000 ft. for LP. This reduction in input results in a correspondingly lower output and must be taken into account when sizing the boiler.
- An air pressure switch (APS) with a lower setting is used.
- The Direct Vent Conversion Kit described in Appendix A is often required to avoid burner “resonance” (a low-pitched humming noise) when the boiler is installed at altitude. If the Direct Vent Conversion Kit is required to eliminate this noise, combustion air may still be drawn from indoors if desired – see Figure B-2).

Table B-1 lists the specific differences between the sea level and high altitude configurations. Boilers that are factory configured for use at altitudes above 2,000 ft. are marked as such on both the packaging and rating plate. The high altitude orifice and pressure switch are factory installed. The appropriate Direct Vent Conversion Kit shown in Table 3-2 is shipped in the boiler crate.

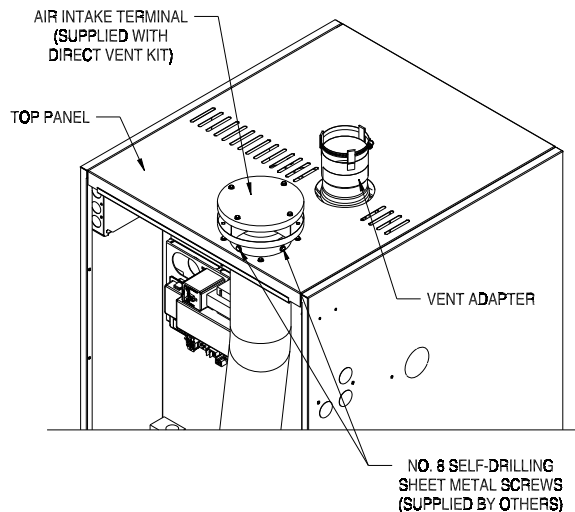
**If indoor air is used for combustion** - The installer may elect to not install the Direct Vent Conversion Kit unless burner resonance is observed. If the Direct Vent Conversion Kit is used, install it according to the instructions provided with the kit. After verifying that there is an adequate air supply inside the boiler room (see Section 6), install the intake terminal directly on the boiler’s intake collar as shown in Figure B-2. Secure with at least two sheet metal screws.

**If combustion air is drawn from outside** – Install the Direct Vent Conversion Kit according to the instructions provided with the kit. Then install the air intake system in accordance with Appendix A.

**Table B-1: Sea Level vs High Altitude Configurations**

| Elevation             | Model     | Main Burner Orifice |                 |                 | Direct Vent Conversion Kit | Air Pressure Switch           |
|-----------------------|-----------|---------------------|-----------------|-----------------|----------------------------|-------------------------------|
|                       |           | Quantity            | Drill Size (PN) |                 |                            |                               |
|                       |           |                     | Nat. Gas        | LP              |                            |                               |
| Sea Level - 2,000 ft. | 3 Section | 4                   | #48<br>(822726) | #56<br>(822707) | Optional                   | 109839-01<br>(1.24 Max Break) |
|                       | 4 Section | 6                   |                 |                 |                            |                               |
|                       | 5 Section | 8                   |                 |                 |                            |                               |
|                       | 6 Section | 10                  |                 |                 |                            |                               |
|                       | 7 Section | 12                  |                 |                 |                            |                               |
|                       | 8 Section | 14                  |                 |                 |                            |                               |
| 2,001-10,200 ft.      | 3 Section | 4                   | #49<br>(822709) | #57<br>(822706) | Standard Equipment         | 110096-01<br>(0.85 Max Break) |
|                       | 4 Section | 6                   |                 |                 |                            |                               |
|                       | 5 Section | 8                   |                 |                 |                            |                               |
|                       | 6 Section | 10                  |                 |                 |                            |                               |
|                       | 7 Section | 12                  |                 |                 |                            |                               |
|                       | 8 Section | 14                  |                 |                 |                            |                               |

## Appendix B *(continued)*



**Figure B-2: Air Intake Terminal (Installed on Air Intake Collar)**

### **⚠ WARNING**

- Safe operation of this boiler depends upon the use of the correct burner orifice AND pressure switch for the altitude at which the boiler is to be installed. See Table B-1 for the correct configuration. Failure to properly configure this boiler for the installation altitude could cause personal injury or death due to carbon monoxide (CO) poisoning.
- Orifice for this boiler cannot be drilled in the field. Obtain orifice for the proper altitude from the local boiler distributor. Part Numbers for the correct size and style orifice are shown in Table B-1.

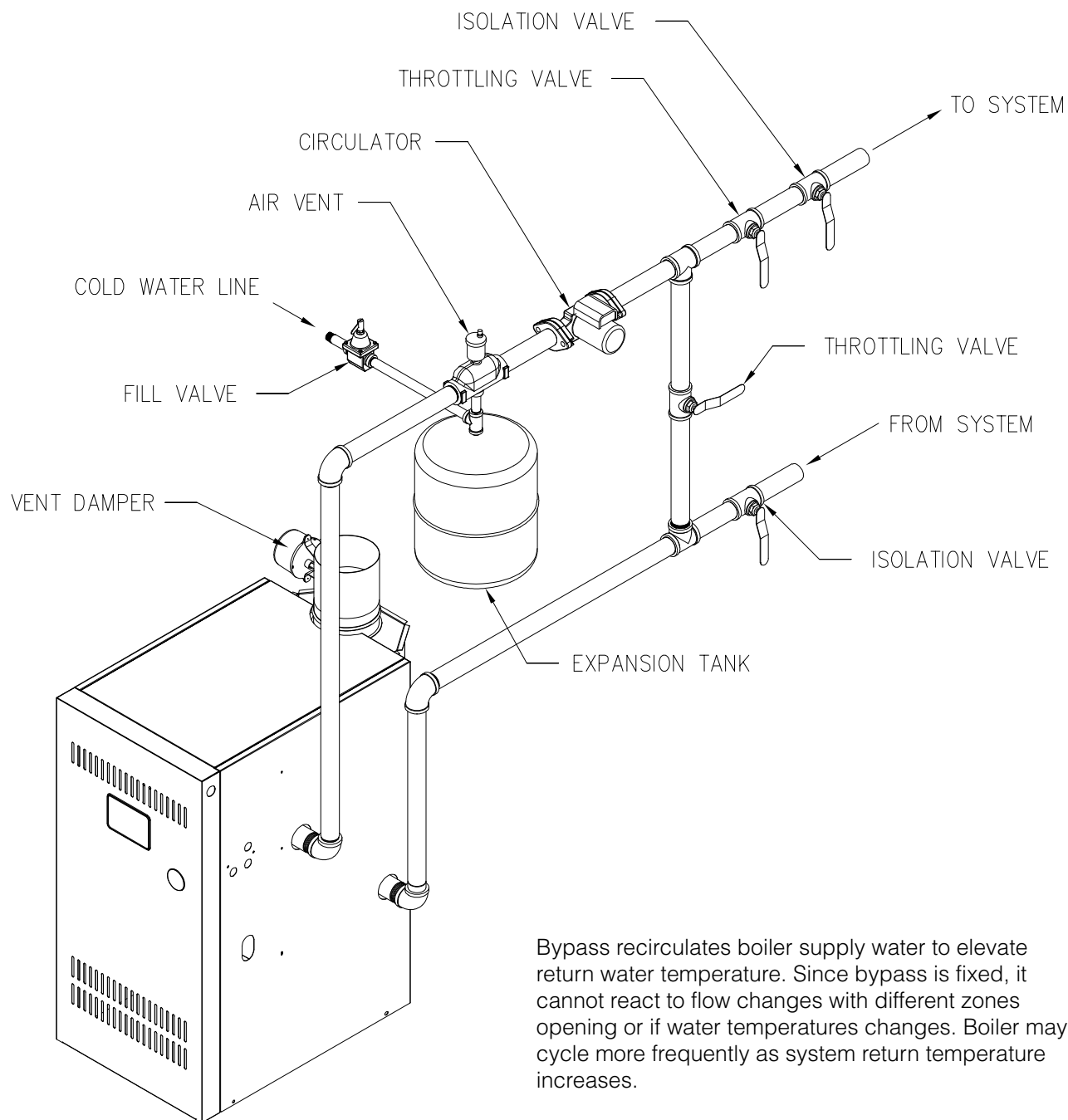
## Appendix C Low Return Water Temperatures

Cast iron boilers will tolerate intermittent periods of condensation, but are not designed for extended condensation periods. Water temperatures below 120°F cause condensation that damage cast iron, burners and other components.

Typical high temperature [170°F and higher] fin tube radiation heating systems will have short condensation cycles in 'shoulder' seasons, early and late parts of the heating season. Short term condensing during these heating season 'shoulders' is unlikely to cause problems.

Larger volume systems during the 'shoulder' heating seasons or systems with aggressive setback or low temperature systems will cause extended condensation periods that will shorten boiler life.

**Simple System By-Pass Arrangements** are common and they can solve flow problems. These simple bypass piping arrangements can help reduce condensation. The figure below shows a system bypass for a single zone or zone valve system.



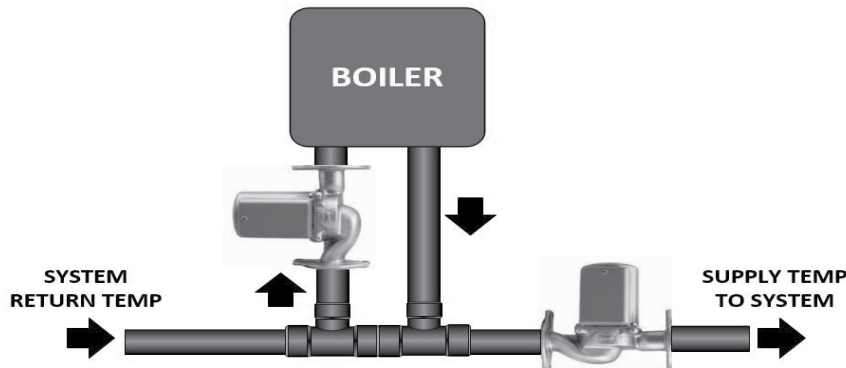
Bypass recirculates boiler supply water to elevate return water temperature. Since bypass is fixed, it cannot react to flow changes with different zones opening or if water temperatures changes. Boiler may cycle more frequently as system return temperature increases.

## Appendix C Low Return Water Temperatures *(continued)*

### Primary-Secondary Pumping:

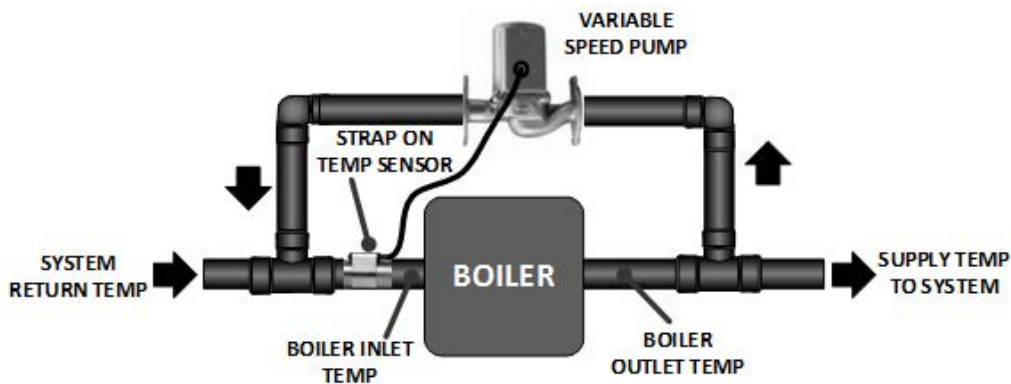
This is an improvement over simple bypass piping to reduce condensation. Again, this is a fixed system. It cannot adapt to variations in temperature and flow.

For this system to minimize condensation, circulators must be sized such that flow through boiler exceeds system flow. Some boiler supply water is then blended with water returning from the system, resulting in a higher boiler return temperature.



### System Bypass with Variable Speed Circulator:

Another approach to minimizing condensation is to use the bypass arrangement shown below. As with primary/secondary pumping, this works by blending some boiler supply water with system return water in order to raise the boiler return water temperature. This can be done using a variable speed pump and return temperature sensor, such as Taco VT2218 or equivalent, so that the bypass flow increases as the system return temperature decreases. This control strategy will maximize flow through the system when the bypass is not needed. If circulator does not include integral check valve, a check valve must also be installed.



## Appendix D: Special Requirements For Side-Wall Vented Appliances In The Commonwealth of Massachusetts

### IMPORTANT

The Commonwealth of Massachusetts requires compliance with regulation 248 CMR 4.00 and 5.00 for installation of side-wall vented gas appliances as follows:

1. For direct-vent appliances, mechanical-vent heating appliances or domestic hot water equipment, where the bottom of the vent terminal and the air intake is installed below four feet above grade the following requirements must be satisfied:
  - A. If there is not already one present, on each floor level where there are bedroom(s), a carbon monoxide detector and alarm shall be placed in the living area outside the bedroom(s). The carbon monoxide detector shall comply with NFPA 720 (2005 Edition).
  - B. A carbon monoxide detector shall be located in the room that houses the appliance or equipment and shall:
    - i.* Be powered by the same electrical circuit as the appliance or equipment such that only one service switch services both the appliance and the carbon monoxide detector;
    - ii.* Have battery back-up power;
    - iii.* Meet ANSI/UL 2034 Standards and comply with NFPA 720 (2005 Edition); and
    - iv.* Have been approved and listed by a Nationally Recognized Testing Laboratory as recognized under 527 CMR.
  - C. A product-approved vent terminal must be used, and if applicable, a product-approved air intake must be used. Installation shall be in strict compliance with the manufacturer's instructions. A copy of the installation instructions shall remain with the appliance or equipment at the completion of the installation.
  - D. A metal or plastic identification plate shall be mounted at the exterior of the building, four feet directly above the location of the vent terminal. The plate shall be of sufficient size to be easily read from a distance of eight feet away, and read "Gas Vent Directly Below".
2. For direct-vent appliances, mechanical-vent heating appliances or domestic hot water equipment, where the bottom of the vent terminal and the air intake is installed above four feet above grade the following requirements must be satisfied:
  - A. If there is not already one present, on each floor level where there are bedroom(s), a carbon monoxide detector and alarm shall be placed in the living area outside the bedroom(s). The carbon monoxide detector shall comply with NFPA 720 (2005 Edition).
  - B. A carbon monoxide detector shall :
    - i.* Be located in the room that houses the appliance or equipment
    - ii.* Be either hard-wired or battery powered or both; and
    - iii.* Comply with NFPA 720 (2005 Edition)
  - C. A product-approved vent terminal must be used, and if applicable, a product-approved air intake must be used. Installation shall be in strict compliance with the manufacturer's instructions. A copy of the installation instructions shall remain with the appliance or equipment at the completion of the installation.





**Velocity Boiler Works, LLC**  
**P.O. Box 14818**  
**3633 I Street**  
**Philadelphia, PA 19134**