

FWC

Models:

- FWC-060
- FWC-080
- FWC-100
- FWC-130
- FWC-160

- High Efficiency
- Oil-Fired, 3-Pass
- Water Boiler
- Natural Draft
- B20 Ready

<u>Manual Contents</u>	<u>Page</u>
1. General Information	5
2. Pre-Installation	6
3. Packaged Boiler Assy.- Trim & Controls	10
4. Water Boiler Piping	19
5. Indirect Water Heater Piping	22
6. Natural Draft Venting (Chimney)	24
7. Electrical	28
8. Oil Piping	31
9. System Start-Up	32
10. Operating	35
11. Maintenance & Service.	39
12. Boiler Cleaning	41
13. Troubleshooting	44
14. Service Parts	45
15. Burner Specifications.	51

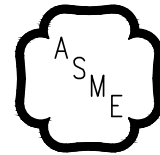

Intertek
9700609

H



IMPORTANT INFORMATION - READ CAREFULLY

All boilers must be installed in accordance with National, State and Local Plumbing, Heating and Electrical Codes and the regulations of the serving utilities. These Codes and Regulations may differ from this instruction manual. Authorities having jurisdiction should be consulted before installations are made.

In all cases, reference should be made to the following Standards:

USA BOILERS

- A. Current Edition of American National Standard ANSI/NFPA 31, "Installation of Oil Burning Equipment"; for recommended installation practices.
- B. Current Edition of American National Standard ANSI/NFPA 211, "Chimneys, Fireplaces, Vents, and Solid Fuel Burning Appliances"; For Venting requirements.
- C. Current Edition of American Society of Mechanical Engineers ASME CSD-1, "Controls and Safety Devices for Automatically Fired Boilers"; for assembly and operations of controls and safety devices.
- D. All wiring on boilers installed in the USA shall be made in accordance with the National Electrical Code and/or Local Regulations.

The following terms are used throughout this manual to bring attention to the presence of hazards of various risk levels, or to important information concerning product life.

DANGER

Indicates a hazardous situation that, if not avoided, will result in death or serious injury.

CAUTION

Indicates a hazardous situation that, if not avoided, could result in minor or moderate injury.

WARNING

Indicates a hazardous situation that, if not avoided, could result in death or serious injury.

NOTICE: Indicates special instructions on installation, operation, or service which are important but not related to personal injury hazards.

NOTICE: This boiler has a limited warranty, a copy of which is printed on the back of this manual.

The warranty for this boiler is valid only if the boiler has been installed, maintained and operated in accordance with these instructions.

Surface rust on cast iron sections may be attributed to the manufacturing process as well as condensation during storage. Surface rust is normal and does not affect the performance or longevity of a boiler.

⚠ DANGER

DO NOT store or use gasoline or other flammable vapors or liquids in the vicinity of this or any other appliance.

⚠ WARNING

- Improper installation, adjustment, alteration, service or maintenance can cause property damage, personal injury or loss of life. Failure to follow all instructions in the proper order can cause personal injury or death. Read and understand all instructions, including all those contained in component manufacturers manuals which are provided with the appliance before installing, starting-up, operating, maintaining or servicing this appliance. Keep this manual and literature in legible condition and posted near appliance for reference by owner and service technician.
- This boiler requires regular maintenance and service to operate safely. Follow the instructions contained in this manual.
- Installation, maintenance, and service must be performed only by an experienced, skilled and knowledgeable installer or service agency.
- All heating systems should be designed by competent contractors and only persons knowledgeable in the layout and installation of hydronic heating systems should attempt installation of any boiler.
- Installation is NOT complete unless a pressure relief valve is installed into the 3/4 in. tapping located on supply piping that was installed into boss on top of rear section - See "Packaged Boiler Assy - Trim & Controls" and "Water Boiler Piping" Sections of this manual for details.
- It is the responsibility of the installing contractor to see that all controls are correctly installed and are operating properly when the installation is complete including verifying that the limit sensor is fully installed. Failure to properly install Limit Sensor may result in property damage, personal injury or loss of life due to elevated operating temperatures and/or pressures.
- Do not install this boiler directly on a combustible surface. Where it is desired to install this boiler over a non-carpeted combustible surface, install the boiler on the base. See Figure 2-2.
- DO NOT tamper with or alter the boiler or controls.
- Inspect flueways at least once a year - preferably at the start of the heating season. The inside of the combustion chamber, the vent system and boiler flueways should be cleaned if soot or scale has accumulated. When cleaning this boiler, take precaution to avoid damage to burner swing door insulation. If damaged, or if there is evidence of previous damage, burner swing door insulation must be replaced immediately.
- Oil Burner and Controls must be checked at least once a year or as may be necessitated.
- DO NOT operate unit with jumpered or absent controls or safety devices.
- DO NOT operate unit if any control, switch, component, or device has been subject to water.
- Boiler materials of construction, products of combustion and the fuel contain alumina, silica, heavy metals, carbon monoxide, nitrogen oxides, aldehydes and/or other toxic or harmful substances which can cause death or serious injury and which are known to the state of California to cause cancer, birth defects and other reproductive harm. Always use proper safety clothing, respirators and equipment when servicing or working nearby the appliance.

 **WARNING**

- This boiler contains very hot water under high pressure. DO NOT unscrew any pipe fittings nor attempt to disconnect any components of this boiler without positively assuring the water is cool and has no pressure.
- Always wear protective clothing and equipment when installing, starting up or servicing this boiler to prevent scald injuries. DO NOT rely on the pressure and temperature gauges to determine the temperature and pressure of the boiler. This boiler contains components which become very hot when the boiler is operating. DO NOT touch any components unless they are cool.
- This boiler must be properly vented. The boiler must be connected to an approved chimney or vent system in good condition. Serious property damage could result if the boiler is connected to a dirty or inadequate chimney or vent system. The chimney must be inspected for any obstructions and cleaned prior to each heating season. A clean and unobstructed chimney flue is necessary to produce the minimum draft required to safely evacuate noxious fumes that could cause personal injury or loss of life. DO NOT operate boiler with the absence of an approved vent system. Evidence of loose debris and or condensate induced stains at the base of the chimney flue, connector or smoke pipe joints may be signs of condensing flue gases. Flue gas condensate is corrosive, which requires special consideration and must be addressed immediately. Refer to "Natural Draft Venting (Chimney)" listed in Table of Contents below.
- This boiler needs fresh air for safe operation and must be installed so there are provisions for adequate combustion and ventilation air.
- This boiler is supplied with controls which may cause the boiler to shut down and not re-start without service. If damage due to frozen pipes is a possibility, the heating system should not be left unattended in cold weather; or appropriate safeguards and alarms should be installed on the heating system to prevent damage if the boiler is inoperative.
- This boiler is designed to burn No. 2 fuel oil including bio blends not exceeding 20% Bio Diesel (ASTM D396) only.
 - DO NOT USE with Flammable Liquids, Gasoline, Crankcase drainings, charcoal lighter fluid, or any oil containing gasoline.
 - DO NOT convert to any solid fuel (i.e., wood, coal).
 - DO NOT convert to any gaseous fuel (i.e., natural gas, LP).
 - DO NOT USE Raw Vegetable Oil (RVO) or any fuel blended with RVO.
 - Use of untested/uncertified fuels could result in explosion, fire, personal injury, or death, and/or damage to equipment and property.
 - Never burn garbage or paper in this boiler.
- All flammable debris, rags, paper, woodscraps, etc., should be kept clear of the boiler at all times. Keep the boiler area clean and free of fire hazards.
- All boilers equipped with burner swing door have a potential hazard which, if ignored, can cause severe property damage, personal injury or loss of life. Before opening swing door turn off service switch to boiler to prevent accidental firing of burner outside the combustion chamber. Be sure to tighten swing door fasteners completely when service is completed.

1 General Information

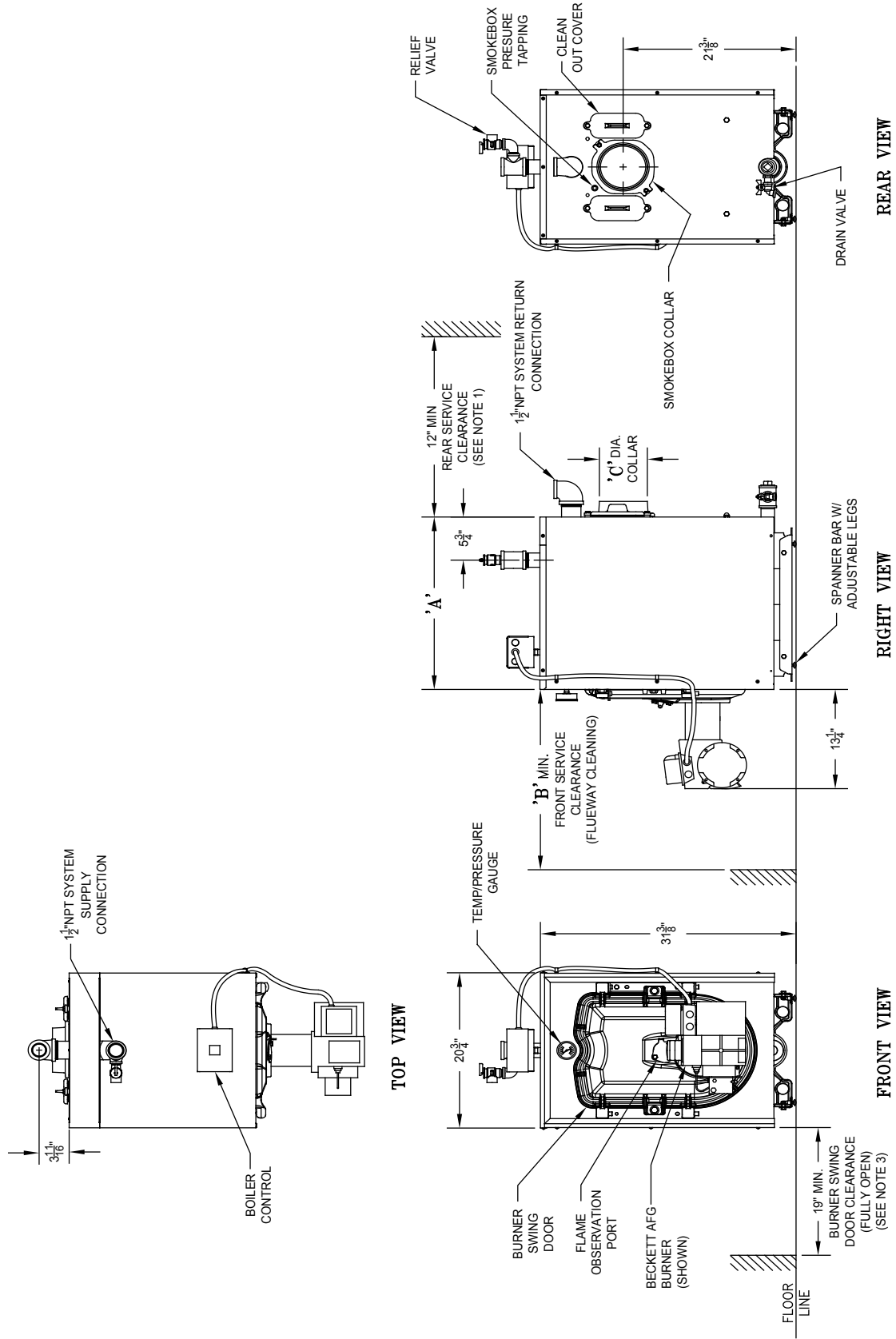

- NOTES:
1. THIS DIMENSION INCREASES AND IS CONTROLLED BY SMOKEPIPE ARRANGEMENT.
 2. DRAIN VALVE AND RELIEF VALVE/FITTINGS SHIPPED LOOSE.
 3. BOILER SHIPPED WITH STANDARD RIGHT HAND HINGE CONFIGURATION, BUT CAN BE CONVERTED TO LEFT HAND HINGE. APPLY CLEARANCE ACCORDINGLY.

Figure 1-1: FWC Water Boiler

1 General Information *(continued)*

Table 1-2: Dimensional

Boiler Model No.	Dimensions See Figure 1-1			Water Content - Gallons	Heat Transfer Surface Area - Sq. Ft.	Actual Shipping Weight (LB.)
	"A"	"B"	"C"			
FWC-060/080	17 in.	24 in.	5 in.	7.70	13.29	430
FWC-100	23 in.	24 in.	6 in.	11.08	20.29	545
FWC-130	29 in.	30 in.	6 in.	14.46	27.29	658
FWC-160	35 in.	36 in.	7 in.	17.84	34.29	771

Table 1-3: Rating Data

Boiler Model No.	Burner Capacity		DOE Heating Capacity (MBH) ⁽²⁾	Net AHRI Ratings- Water (MBH) ⁽³⁾	AFUE %
	GPH	MBH ⁽¹⁾			
FWC-060	0.60	84	74	64	87.0
FWC-080	0.80	115	101	88	87.0
FWC-100	1.00	140	123	107	87.0
FWC-130	1.30	182	160	139	87.0
FWC-160	1.60	224	197	171	87.0

1. MBH refers to thousands of BTU per hour.

2. Based on Standard Test prescribed by the United States Department of Energy at combustion conditions of 13.0% CO₂.

3. Net AHRI water ratings based on a piping and pickup allowance of 1.15.

NOTE: The rating shown are based on the use of #2 Heating Oil.

2 Pre-Installation

A. INSPECT SHIPMENT carefully for any signs of damage.

- All equipment is carefully manufactured, inspected and packed. Our responsibility ceases upon delivery of crated boiler to the carrier in good condition.
- Any claims for damage or shortage in shipment must be filed immediately against the carrier by the consignee. No claims for variances from, or shortage in orders, will be allowed by the manufacturer unless presented within sixty (60) days after receipt of goods.

B. LOCATE BOILER in front of final position before removing crate. See Figure 1-1.

- LOCATE so that vent pipe connection to chimney will be short and direct.
- FOR BASEMENT INSTALLATION, provide a solid elevated base, such as concrete, if floor is not level, or if water may be encountered on floor around boiler.
- PROVIDE RECOMMENDED SERVICE CLEARANCE, if applicable, as follows:
 - Clearance from Jacket Front Panel -
 - 24 in. for servicing burner
 - 24 in. for flueway cleaning (FWC-060 thru FWC-100)

2 Pre-Installation *(continued)*

- 30 in. for flueway cleaning (FWC-130)
 - 36 in. for flueway cleaning (FWC-160)
- b. Clearance from Jacket Left Side Panel -
- 19 in. for burner swing door, if opened fully with burner mounted, otherwise 1 in. with burner removed
 - 12 in. access clearance to service rear of boiler if right side clearance is less than 12 in.
 - 3 in. minimum if right side clearance is 12 in. or larger to access and service rear of boiler.
- c. Clearance from Jacket Right Side Panel -
- 3 in. minimum if left side clearance is 12 in. or larger to access and service rear of boiler.
- d. Clearance from Jacket Rear Panel -
- 12 in. minimum for rear smokebox cleaning
- (NOTE:** This dimension will also be controlled by horizontal to vertical to horizontal smokepipe arrangement - **Chimney Vent** (see Figures 2-1 and 6-1).
4. For minimum clearances to combustible materials. See Figure 2-1.

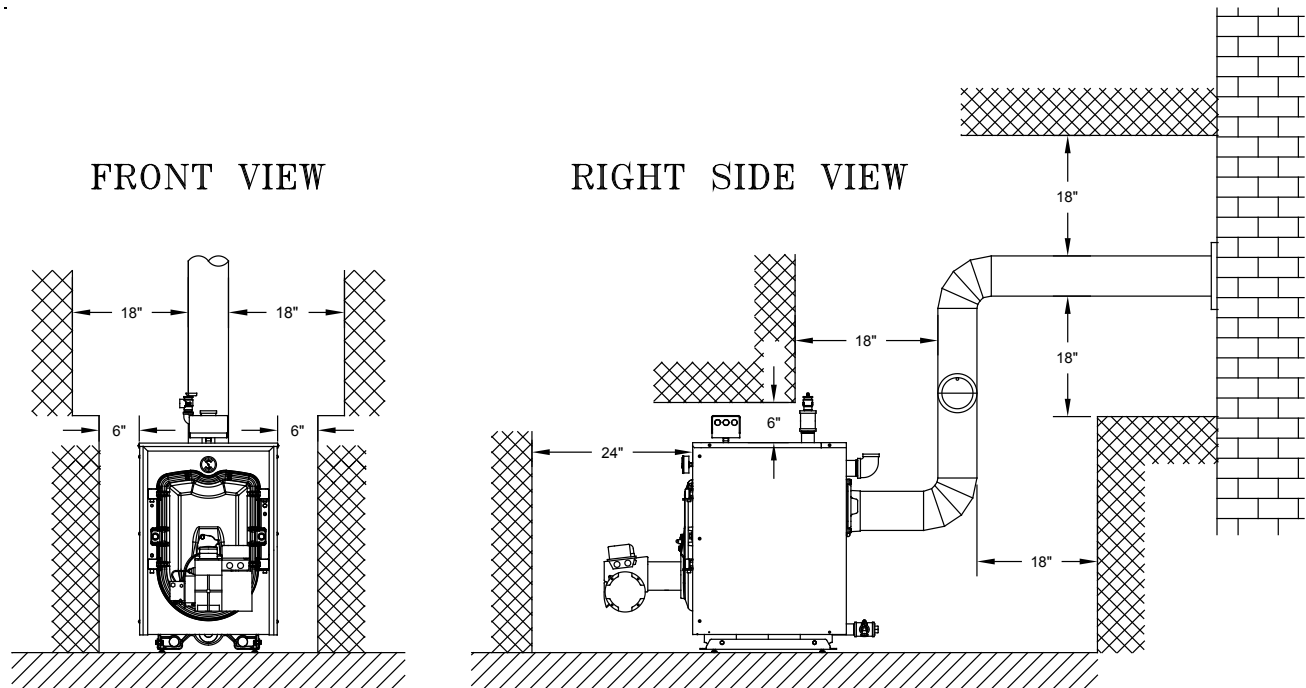

Figure 2-1: Chimney Vent - Minimum Installation Clearances To Combustible Materials (Inches)

- NOTES:**
1. Listed clearances comply with American National Standard ANSI/NFPA 31, *Standard for the Installation of Oil Burning Equipment*.
 2. FWC boilers can be installed in rooms with clearances from combustible material as listed above. Listed clearances cannot be reduced for alcove or closet installations.
 3. For reduced clearances to combustible material, protection must be provided as described in the above ANSI/NFPA 31 standard.

2 Pre-Installation *(continued)*

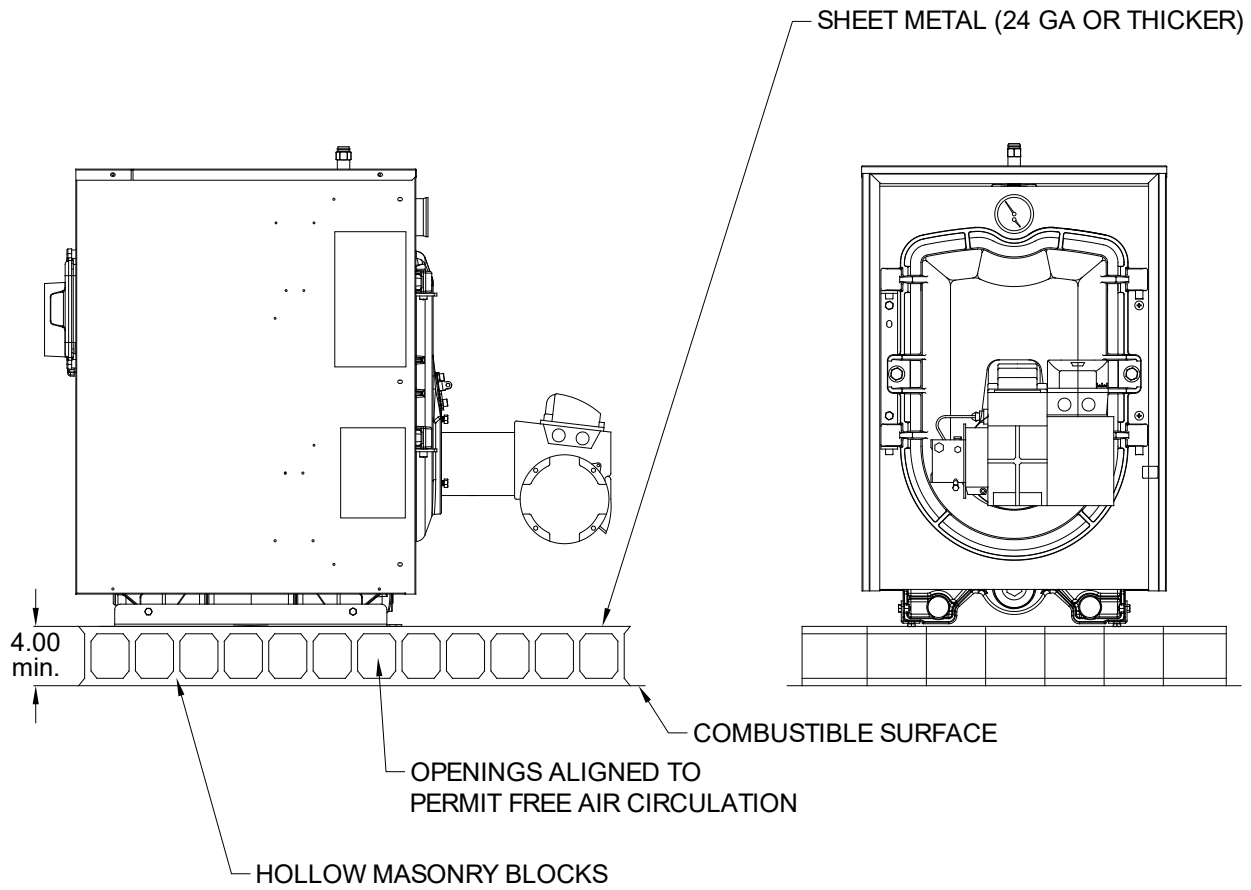

Figure 2-2: Installation Over a Combustible Floor

2 Pre-Installation *(continued)*

NOTICE: Clearance to venting is for single wall vent pipe. If Type L vent is used, clearance may be reduced to the minimum required by the vent pipe manufacturer.

C. PROVIDE COMBUSTION AND VENTILATION

AIR. Local and National Codes may apply and should be referenced.

WARNING

Adequate combustion and ventilation air must be provided to assure proper combustion and to maintain safe ambient air temperatures. Do not install boiler where gasoline or other flammable vapors or liquids, or sources of hydrocarbons (i.e. bleaches, fabric softeners, etc.) are used or stored.

1. Determine volume of space (boiler room). Rooms communicating directly with the space in which the appliances are installed, through openings not furnished with doors, are considered a part of the space.

$$\text{Volume}(\text{ft}^3) = \text{Length}(\text{ft}) \times \text{Width}(\text{ft}) \times \text{Height}(\text{ft})$$
2. Determine total input of all appliances in the space.
 Add inputs of all appliances in the space and round the result to the nearest 1,000 BTU per hour.
3. Determine type of space. Divide Volume by total input of all appliances in space. If the result is greater than or equal to 50 ft³/1,000 BTU per hour, then it is considered an **unconfined space**. If the result is less than 50 ft³/1,000 BTU per hour then the space is considered a **confined space**.
4. For boiler located in an *unconfined space of a conventionally constructed building*, the fresh air infiltration through cracks around windows and doors normally provides adequate air for combustion and ventilation.
5. For boiler located in a confined space or an unconfined space in a building of **unusually tight construction**, provide outdoor air. Outdoor air may be provided with the use of two permanent openings which communicate directly or by duct with the outdoors or spaces (crawl or attic) freely communicating with the outdoors. Locate one opening within 12 inches of top of space. Locate remaining opening within 12 inches of bottom of space. Minimum dimension of air opening is 3 inches. Size each opening per following:
 - a. **Direct communication with outdoors.**
 - Minimum free area of 1 square inch per 4,000 BTU per hour input of all equipment in space.
 - b. **Vertical ducts.** Minimum free area of 1 square inch per 4,000 BTU per hour input of all equipment in space. Duct cross-sectional area shall be same as opening free area.
 - c. **Horizontal ducts.** Minimum free area of 1 square inch per 2,000 BTU per hour input of all equipment in space. Duct cross-sectional area shall be same as opening free area. *Alternate method for boiler located within confined space.* Use indoor air if two permanent openings communicate directly with additional space(s) of sufficient volume such that combined volume of all spaces meet criteria for unconfined space. Size each opening for minimum free area of 1 square inch per 1,000 BTU per hour input of all equipment in spaces, but not less than 100 square inches.
6. Louvers and Grilles of Ventilation Ducts
 - a. All outside openings should be screened and louvered. Screens used should not be smaller than 1/4 inch mesh. Louvers will prevent the entrance of rain and snow.
 - b. Free area requirements need to consider the blocking effect of louvers, grilles, or screens protecting the openings. If the free area of the louver or grille is not known, assume wood louvers have 20-25 percent free area and metal louvers and grilles have 60-75 percent free area.
 - c. Louvers and grilles must be fixed in the open position, or interlocked with the equipment to open automatically during equipment operation.

3 Packaged Boiler Assembly - Trim & Controls

A. REMOVE CRATE.

1. Remove all fasteners at crate skid.
2. Lift outside container and remove all other inside protective spacers and bracing. Remove miscellaneous parts carton.

B. REMOVE BOILER FROM SKID.

1. To reduce the risk of damage to boiler jacket, use the following procedure to remove from skid, see Figure 3-1:

Step 1. Boiler is secured to base with (4) 5/16 in. cap screws, (2) in front and (2) in rear of shipping skid, see Figure 3-1. Remove all securing hardware.

Step 2. Place wooden block(s) 12 in. from rear of skid as shown (one piece 4 in. x 4 in. x 16 in. lg. or two pieces of 2 in. x 4 in. x 16 in. lg.)

Step 3. Insert 1 in. Sch. 40 pipe handles through leg hole in front and rear legs. Center end of pipe on wooden blocks as shown in Figure 3-1.

NOTE: Pipe handles should extend a minimum of 48 in. beyond jacket front panel for best leverage.

Step 4. Using the pipe handles, lift boiler until adjustable legs are elevated above the deck boards.

Step 5. Remove skid from underneath the boiler.

Step 6. Lower pipe handles until front adjustable legs touch floor. If necessary, place wooden blocks under front legs before lowering to provide hand clearance.

Step 7. To lower rear of boiler, tilt unit slightly forward by pushing on smokebox collar or lift pipes protruding through rear legs until wooden blocks can be removed (see Figure 3-1). Slowly allow the weight of the boiler to tilt backward until rear legs rest on floor.

Step 8. If wood block was placed under front legs, lift pipe handles, remove wooden block and lower front legs to floor. Remove pipe handles.

⚠ CAUTION

Do not drop boiler. Do not bump boiler jacket against floor.

C. MOVE BOILER TO PERMANENT POSITION by sliding or walking.

D. PROCEDURE TO OPEN, CLOSE AND SECURE BURNER SWING DOOR

Throughout this manual you will be instructed to open and close the burner swing door for various reasons. There is a proper and improper method to closing and securing the burner swing door opened for inspection, cleaning or field service.

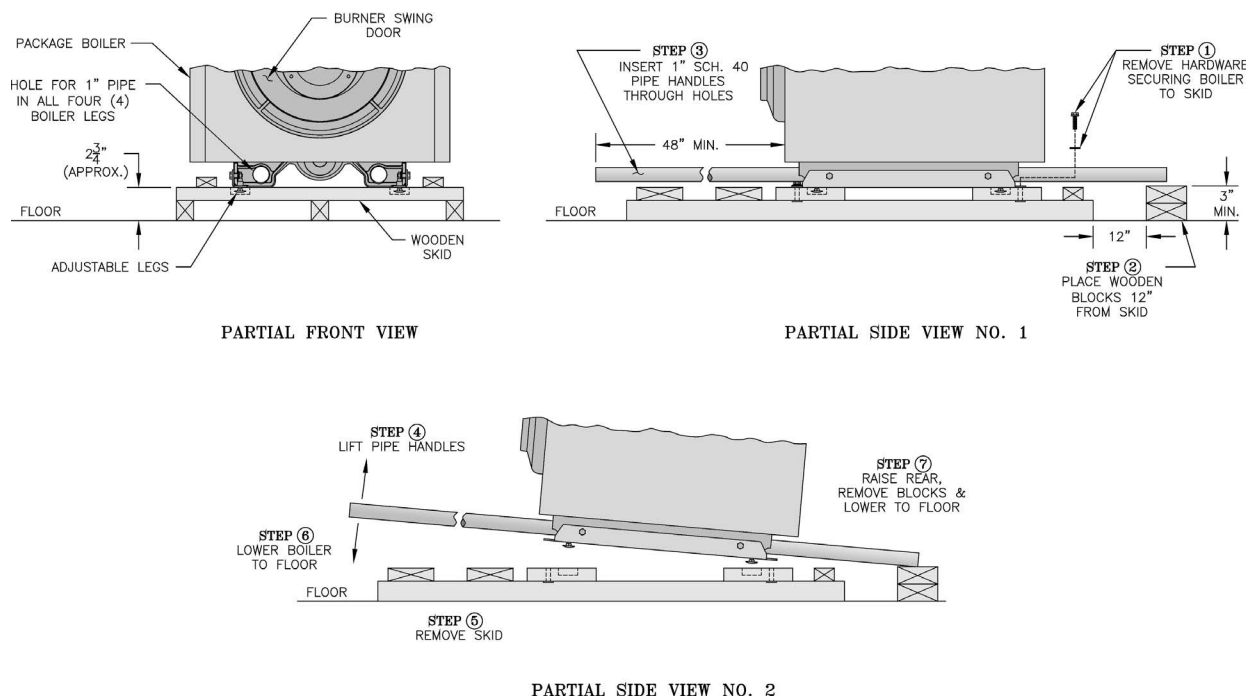

Figure 3-1: Packaged Boiler Removal from Skid

3 Packaged Boiler Assembly - Trim & Controls *(continued)*

1. TO OPEN BURNER SWING DOOR

(see Figures 3-2 and 3-3).

Step 1. Loosen but do not remove left side latching hardware (3/8 in. x 1-3/4 in. lg. tap bolt).

Step 2. Loosen and remove right side latching hardware (3/8 in. x 1-3/4 in. lg. tap bolt and washer).

Step 3. Remove left side latching hardware (3/8 in. x 1-3/4 in. lg. tap bolt and washer).

Step 4. Disconnect burner power cord from receptacle located in lower right corner of jacket front panel.

Step 5. Door can be swung to the fully open position, approximately 90° to 120°, with the burner mounted providing that there is 19 in. of clearance to the adjacent wall, see Figure 1-1.

NOTE: If reduced clearance prevents the door from opening fully, one of the following can provide full access:

- Burner can be removed to allow full rotation of door.
- Door with burner mounted can be lifted off mounting bracket and set aside during servicing.
- The door mounting hardware is reversible from left side hinge (as shipped) to right side hinge.

To reverse hinge arrangement (see Figure 3-2:

- Lift door off mounting bracket and set aside.
- Remove mounting bracket and hardware from left side.
- Remove upper jacket front panel retaining screw (5/16 in. x 1/2 in. lg. Phillip Pan head machine screw) from right side of door and re-install in vacated upper mounting bracket tapping.
- Do not tighten.
- Move lower jacket panel retaining screw from right side to left tapping. Do not tighten.
- Rotate door mounting bracket 180°. Insert 5/16 in. cap screw through top hole in bracket and install in upper vacated jacket hole on right side of door.
- Install second 5/16 in. cap through bracket hole into lower vacated tapping on right side.
- Tighten both sets of hardware to secure jacket and mounting bracket.
- Lift door and place integral cast hinge pins on door into slotted mounting bracket holes.

2. Perform routine inspection, service or cleaning as necessary.

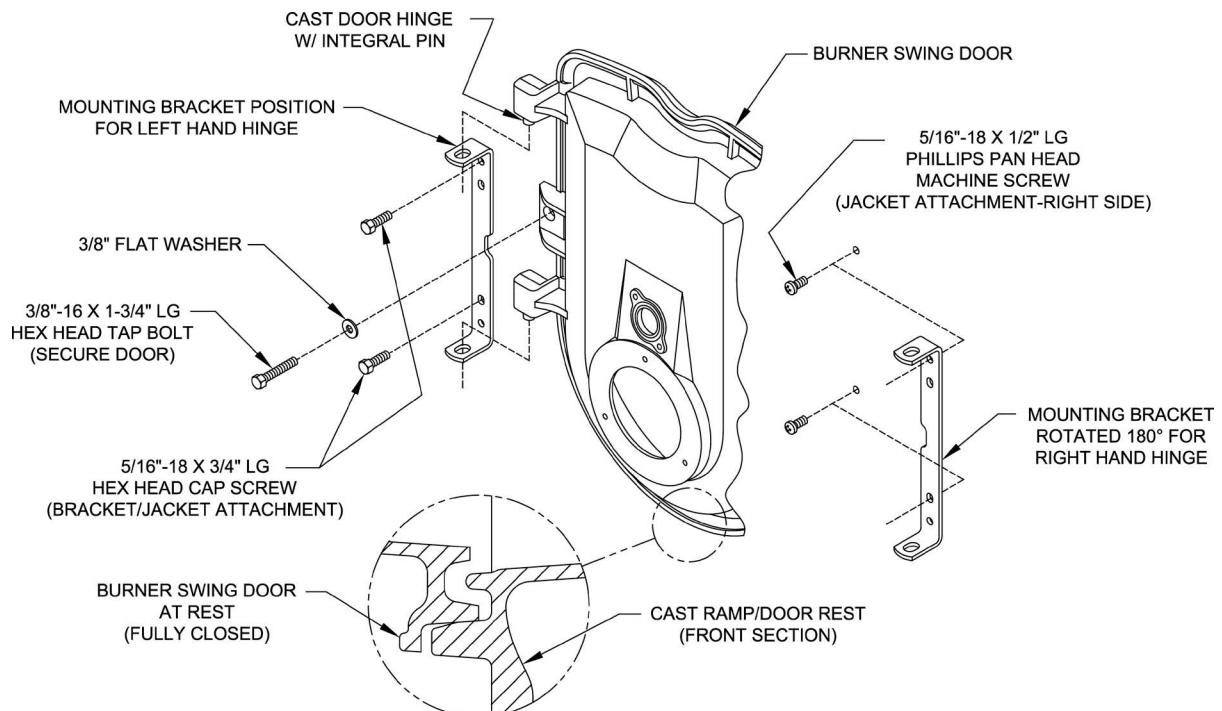
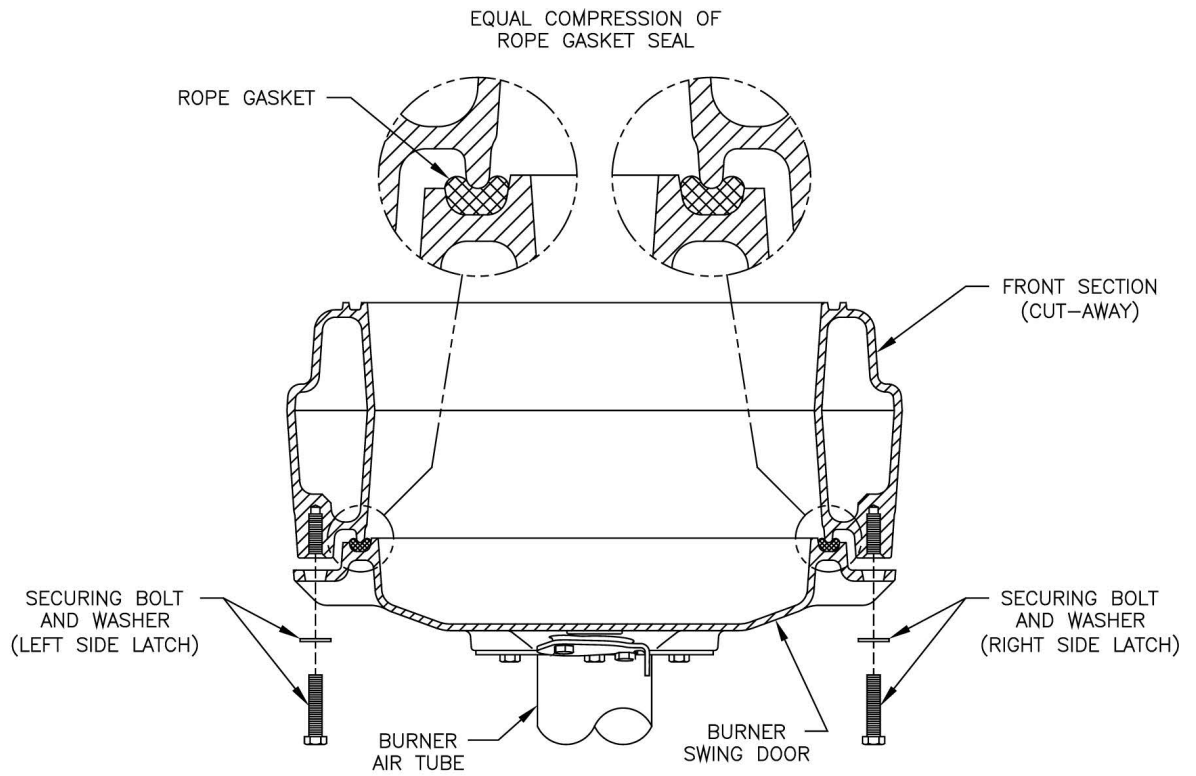
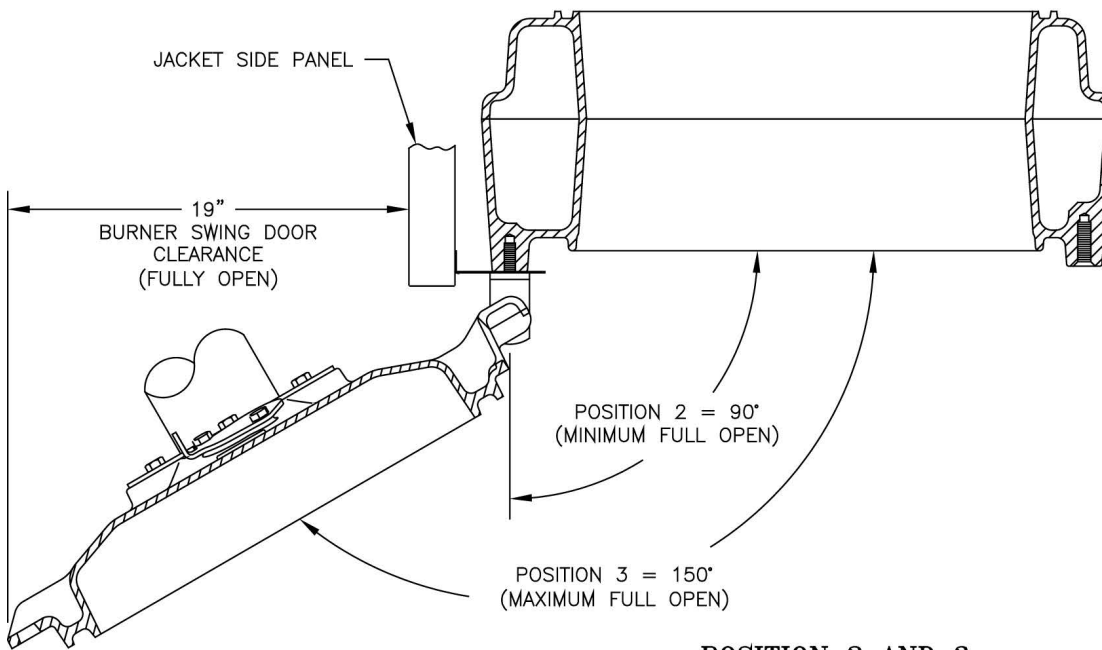

Figure 3-2: Partial Front View - Burner Swing Door Mounted to Boiler - Fully Closed and Secured

3 Packaged Boiler Assembly - Trim & Controls *(continued)*



POSITION 1
(PROPERLY CLOSED AND SECURED)



POSITION 2 AND 3
(SWING RADIUS TO FULL OPEN POSITION)

Figure 3-3: Top View - Burner Swing Door Mounted to Cast Iron Block Assembly (Jacket Removed for Clarity)

3 Packaged Boiler Assembly - Trim & Controls *(continued)*

3. To close Burner Swing Door (see Figures 3-2 and 3-3):

Step 1. From the fully open position, rotate Burner Swing Door to the closed position.

Step 2. If necessary, place your right hand under the burner air tube to lift upward. Lift the door up onto the built-in cast ramp/door rest (protruding from the bottom of the front section casting - see Figure 3-2).

Step 3. Use one hand to help hold door in position by lifting up on rear burner housing or applying pressure directly to the door while re-installing the securing hardware with your opposite hand. **Always install right side latching hardware (3/8 in.-16 x 1-3/4 in. lg. tap bolt and flat washer) first**, then install left side hinge hardware (3/8 in.-16 x 1-3/4 in. lg. tap bolt and flat washer) **second**. Apply additional pressure while hand tightening the hardware as far as possible, then release the pressure.

NOTICE: When securing burner swing door make sure door is drawn-in equally on both sides.

Step 4. Use a hand wrench to tighten door hardware and **always start with the right side cap screw first**. Use an alternating tightening method from right side tap bolt to

left side tap bolt to tighten door equally until sealed without applying excessive torque. Never tighten left side flange bolt first or tighten either piece of hardware 100% without using the alternating tightening method described above.

Failure to follow the prescribed procedure could cause thread damage to casting or a leak in the door seal. If left side tap bolt is tightened before right side tap bolt, right side of door can not be drawn-in to provide an air tight seal, as shown in Figure 3-4.

Applying excessive torque will only cause thread damage.

E. INSPECT SWING DOOR INSULATION AND ROPE GASKET.

1. Open burner swing door using procedure previously outlined in Paragraph D of this section.
2. Inspect fiberglass rope located on the swing door. The rope must be evenly distributed around the perimeter of the door groove and cannot bunch or overhang. There must not be a gap where the two ends of the rope meet. Repair or replace if the rope is damaged or if there is a gap between the ends.
3. Inspect burner swing door insulation for damage and proper type.

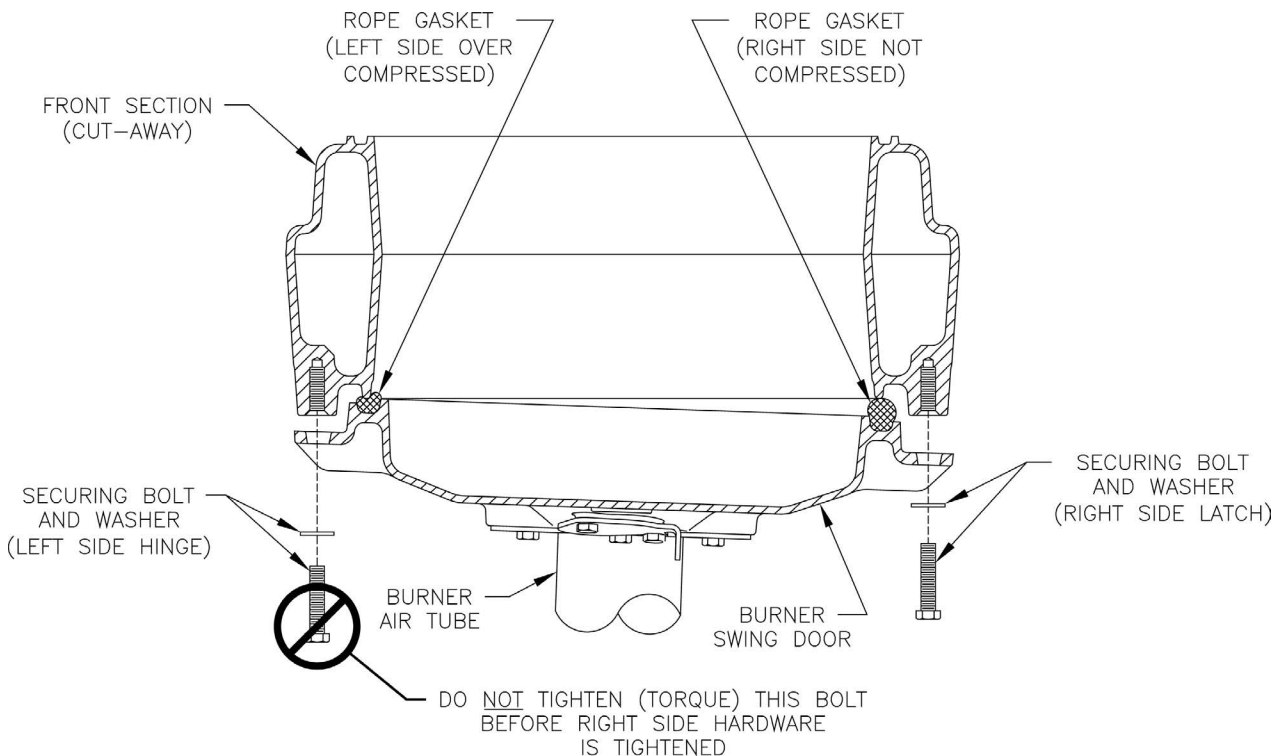

Figure 3-4: Top View - Burner Swing Door Fully Closed but Not Properly Secured or Sealed

3 Packaged Boiler Assembly - Trim & Controls *(continued)*

By design, cast bars on front section between the combustion chamber and between the left and right side 2nd and 3rd pass flueway should make an impression in door insulation to seal the chambers.

If insulation is damaged or not of proper type regarding pockets, it must be replaced.

- Do not close and secure door at this time, proceed to Field Assembly Details, Paragraph F.

F. FIELD ASSEMBLY OF BOILER TRIM AND CONTROLS

Open miscellaneous parts carton and remove contents. Identify the components using the illustrations (see Figure 3-5) throughout the assembly sequence outlined below as it applies to your installation.

- Install supply piping and relief valve, refer to Figures 1-1 and 3-5.

Step a. Locate the supply piping supplied with boiler. Apply thread sealant to all joints prior to assembly. Thread 1½ in. NPT x 6 in. long supply nipple into 1½ in. NPT tapping on the topside of the rear section. Thread 1½ in. x 1½ in. x ¾ in. NPT tee onto 6 in. nipple. Tighten all joints until watertight and ¾ in. NPT connection on tee is positioned to allow clearance for relief valve discharge.

Step b. Locate the relief valve piping supplied with boiler. Apply thread sealant to all joints prior to assembly. Thread the ¾ in. NPT street elbow onto tee listed above. Install relief valve into street elbow. Tighten all joints until watertight and relief valve is positioned to allow clearance for discharge. Installation of the relief valve must be consistent with ANSI/ASME Boiler and Pressure Vessel Code, Section IV.

⚠ WARNING

Safety valve discharge piping must be piped near floor to eliminate potential of severe burns. Do not pipe in any area where freezing could occur. Do not install any shut-off valves, plugs or caps.

- Install Boiler Control

- Locate the Boiler Control/Harness Assembly in the Miscellaneous Parts Carton. Loosen mounting clamp screw on front of Control. Mount Control on factory installed immersion well located in top tapping near front of boiler with burner harness on the right hand side; see Figure 3-5.
- Locate (2) 5/8 in. cable clamps in parts carton. Secure burner wiring harness to front of jacket right side panel with cable clamps and existing jacket screws at top and mid-point as shown in Figure 3-5.

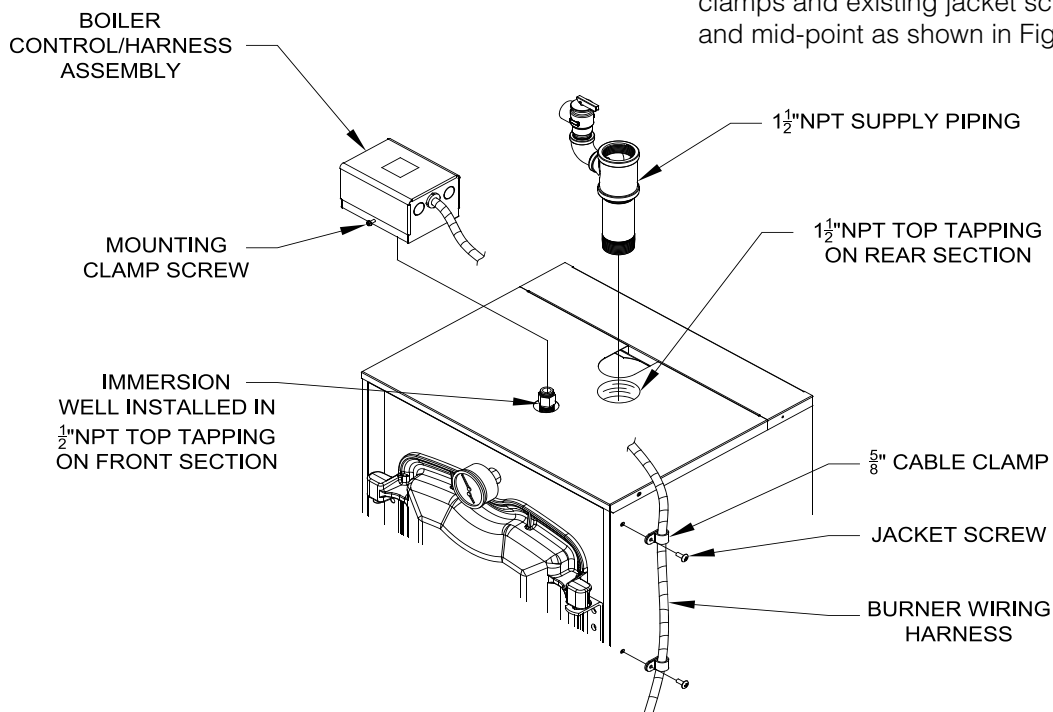

Figure 3-5: Supply Piping and Aquastat Control Assembly Details

3 Packaged Boiler Assembly - Trim & Controls *(continued)*

- c. Locate the Limit sensor inside Boiler Control. Carefully connect sensor into the Boiler Control circuit board by pressing connector on sensor unit into mating connector on circuit board (refer to Figure 11-1). Insert sensor through hole in circuit board and into immersion well until it rests against the bottom of the well as shown in Figure 3-6.

3. Install return injector piping and relief valve, refer to Figure 3-7.

Step a. Locate the return pipe fittings and injector. Apply sealant to the 2 in. NPT injector threads. Insert injector into 2 in. NPT upper rear tapping on rear section. Thread 2 in. NPT x 1-1/2 in. Reducing Elbow onto 2" NPT injector.

Note: Based on system return piping and access to service boiler, see Figures 1-1, 4-2 and 4-3, predetermine if injector piping orientation is to be positioned for vertical, horizontal left or horizontal right side return piping as shown in Figure 3-7.

4. Install drain valve, see Figure 3-8.

Step a. Apply pipe sealant to both ends of 1-1/4 in. NPT x 5 in. lg. nipple. Thread nipple into 1-1/4 in. NPT lower rear tapping on rear section.

Step b. Thread 1-1/4 in. x 1-1/4 in. x 3/4 in. NPT tee on opposite end of 5 in. lg. nipple installed in Step a.

NOTE: Based on access for servicing and location of sewer or floor drain, when tightening these fittings, determine if drain valve is to be located on the left or right side.

Tighten nipple and tee into 1-1/4 in. NPT lower rear tapping on rear section until joints are water tight for desired position.

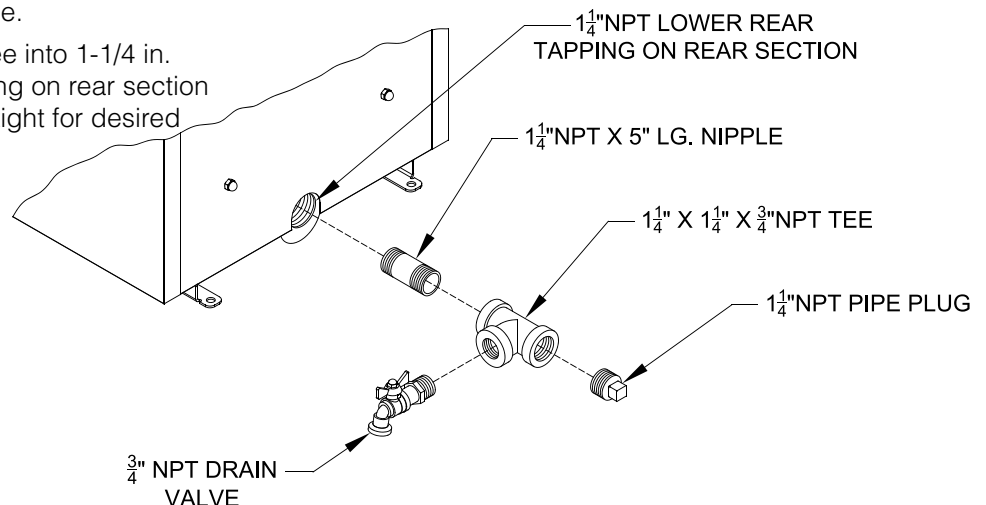

Figure 3-8: Piping Arrangement for Drain Valve and Indirect Water Heating Return

Step c. Apply sealant to 3/4 in. NPT thread on drain valve. Thread into 3/4 in. NPT tapping on side outlet of tee. Use hex nut portion to tighten valve until water tight.

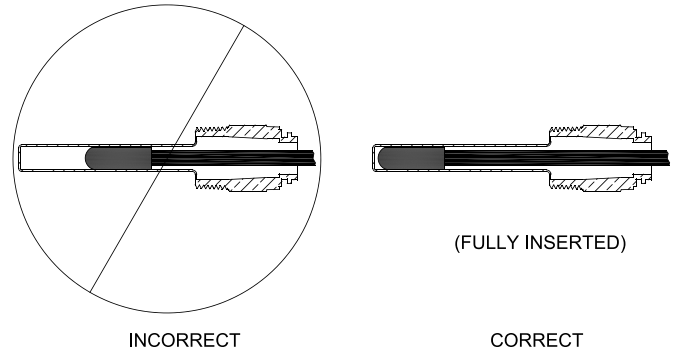

Figure 3-6: Limit Sensor Insertion

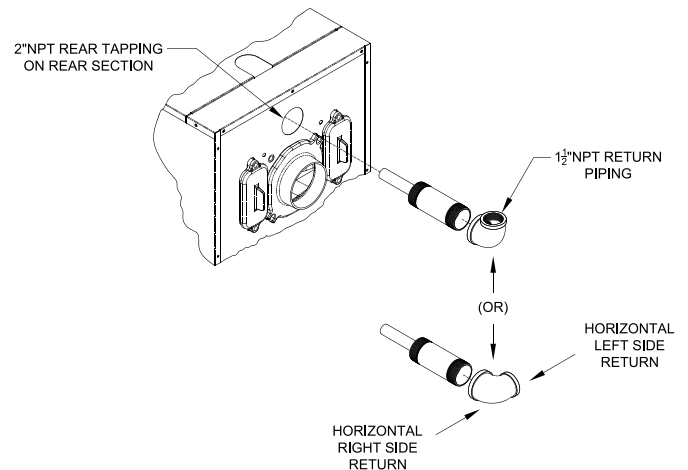

Figure 3-7: Return Injector Piping and Relief Valve Assembly Details

3 Packaged Boiler Assembly - Trim & Controls *(continued)*

5. Connect Field Wiring.

Step a. Connect the field wiring from the circulator to the aquastat control. Make the wiring connections as shown on Figures 8-1 or 8-2.

6. Installing stainless steel flueway baffles. Baffle requirements differ from model to model, see Table 3-9.

NOTE: Read caution statement before proceeding.

Table 3-9: Baffle Usage

Boiler Model	Boiler Usage		
	2nd Pass	3rd Pass	Combustion Chamber Ring
FWC-060	[2] 102066-01	None	
FWC-080	[2] 109902-01	[2] 100081-01	[2] 111752-01
FWC-100	[2] 100042-01	None	None
FWC-130			
FWC-160			

CAUTION

These baffles will generate higher efficiencies and lower stack temperatures. Under certain conditions, a lower gross stack temperature entering the chimney has the potential to be cooled below the dew point and create condensate on interior surfaces. Flue gas condensate is corrosive, which requires special consideration and must be addressed immediately.

DO NOT install baffles until you have read Sections 6 and 7, completely (venting details).

Step a. Install stainless steel baffles provided in miscellaneous parts carton as follows, refer to Table 3-9 and Figure 3-10 and 3-11:

- Model FWC-060 - To install flueway baffle in 2nd pass on left side of boiler, hold baffle with word "Left" readable at the top. Slide baffle in flueway until position tab touches fins on left side of 2nd pass flueway. To install flueway baffle in 2nd pass flueway on right side of boiler, hold baffle with word "Right" readable at the top. Slide baffle in flueway until position tab touches fins on right side of 2nd pass flueway.

- Model FWC-080 - To install flueway baffle in 3rd pass on left side of boiler, hold baffle with word "Left" readable at the top. Slide baffle in flueway until position tab touches fins on left side of 3rd pass flueway. To install flueway baffle in 3rd pass flueway on right side of boiler, hold baffle with word "Right" readable at the top. Slide baffle in flueway until position tab touches fins on right side of 3rd pass flueway. To install flueway baffle in 2nd pass on left side of boiler, hold baffle with word "Left" readable at the top. Slide baffle in flueway until position tab touches fins on left side of 3rd pass flueway. To install flueway baffle in 2nd pass flueway on right side of boiler, hold baffle with word "Right" readable at the top. Slide baffle in flueway until position tab touches fins on right side of 3rd pass flueway.

To install the combustion chamber ring, place in the center of the combustion chamber. The positive stop will meet the front of the front section, positioning the Combustion Chamber Ring towards the front. See Figure 3-10.

- Models FWC-100 thru FWC-160 – To install flueway baffle in 2nd pass flueway on left side of boiler, hold baffle with word "Left" readable at the top. Slide baffle in flueway until position tab touches fins on right side of 2nd pass flueway. To install flueway baffle in 2nd pass flueway on right side of boiler, hold baffle with word "Right" readable at the top. Slide baffle in flueway until position tab touches fins on left side of 2nd pass flueway.

NOTE: 2nd and 3rd pass flueway baffle are not interchangeable.

7. **Close the burner swing door** and securely seal the door to the boiler front section by reinstalling the hardware and securing the door using procedure previously outlined in Paragraph D of this section.

NOTICE: When securing burner swing door make sure door is drawn-in equally on both sides.

3 Packaged Boiler Assembly - Trim & Controls *(continued)*

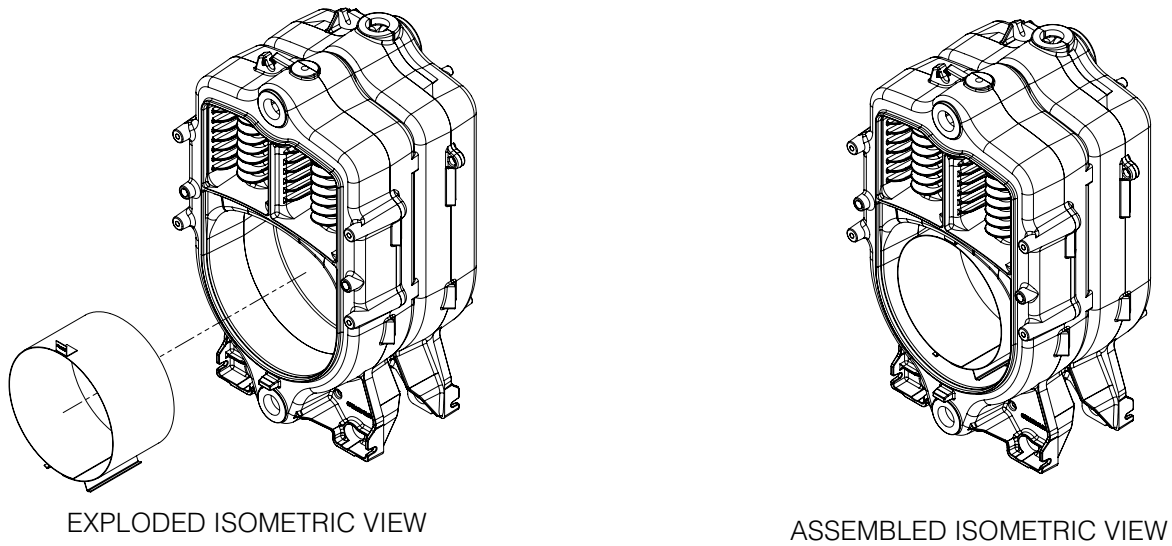

Figure 3-10: Combustion Chamber Ring Installation

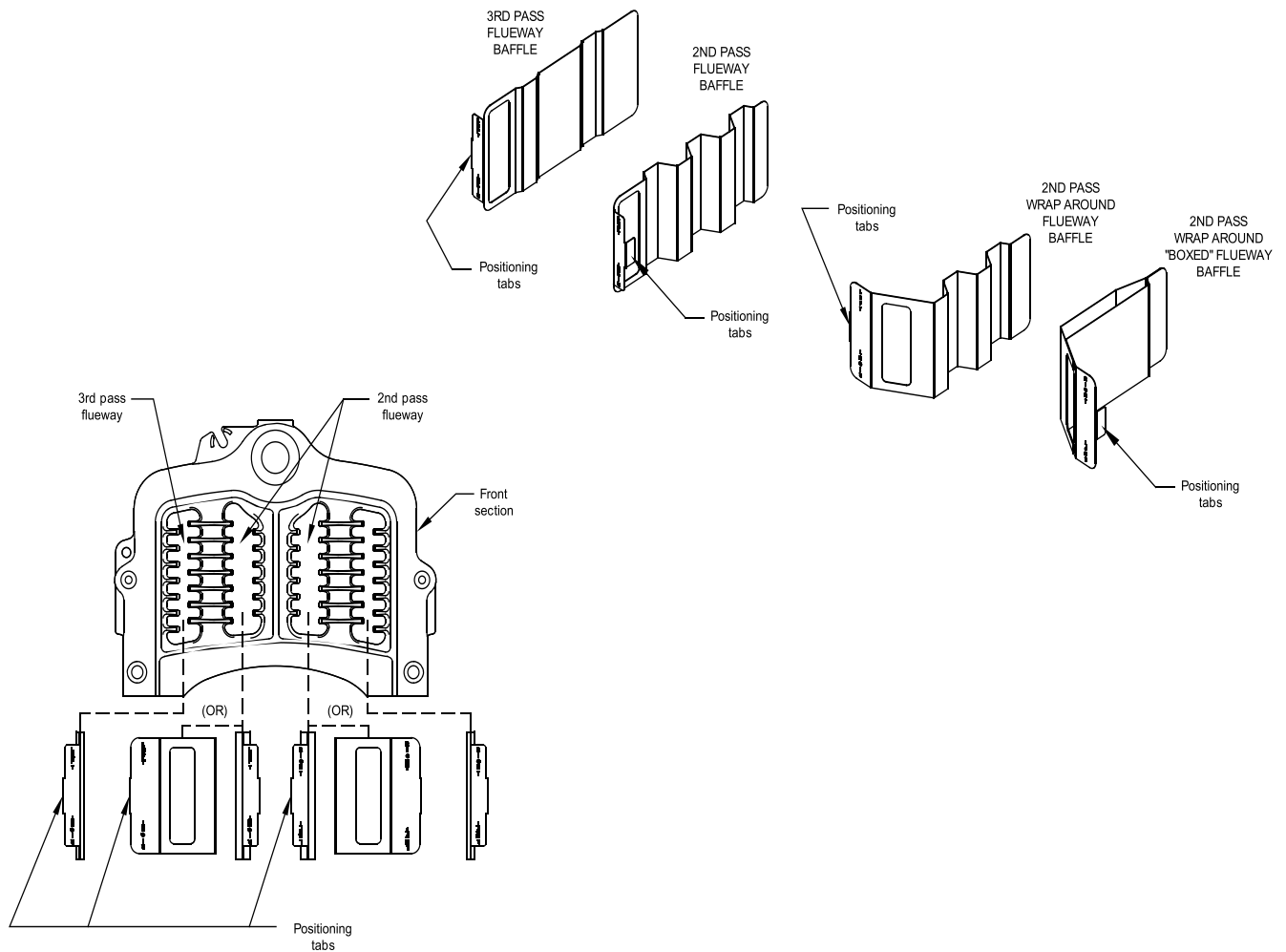

Figure 3-11: Baffle Orientation in Flueways

3 Packaged Boiler Assembly - Trim & Controls *(continued)*

8. **Install oil burner.** (See Figure 3-12 and Table 3-13)

Step a. Open burner carton and remove contents.

Step b. Place oil burner gasket on burner and align holes.

CAUTION

Do not install burner without gasket.

Step c. Remove three (3) 5/16-18 x 3/4 lg. cap screw from burner swing door used for mounting burner.

Step d. Thread (1) 5/16-18 x 3/4 lg. cap screw, approximately three (3) full turns, into tapping located at 12:00 o'clock on burner swing door.

Step e. Insert oil burner into the opening of burner swing door. Align and engage keyhole slot in burner flange over head of protruding cap screw installed in previous Step. Rotate burner to the right to lock flange behind head of cap screw.

Step f. Align holes and install two (2) remaining cap screws. Level burner and fully tighten all three (3) screws.

Step g. Plug burner power cord into Boiler Control harness.

Step h. Check oil nozzle in burner for size, angle and spray type; inspect electrode settings and head/air plate setting. Refer to Tables 15-1 and 15-2 and Section 10. Refer to Burner Manufacturer's Manual for detail instructions.

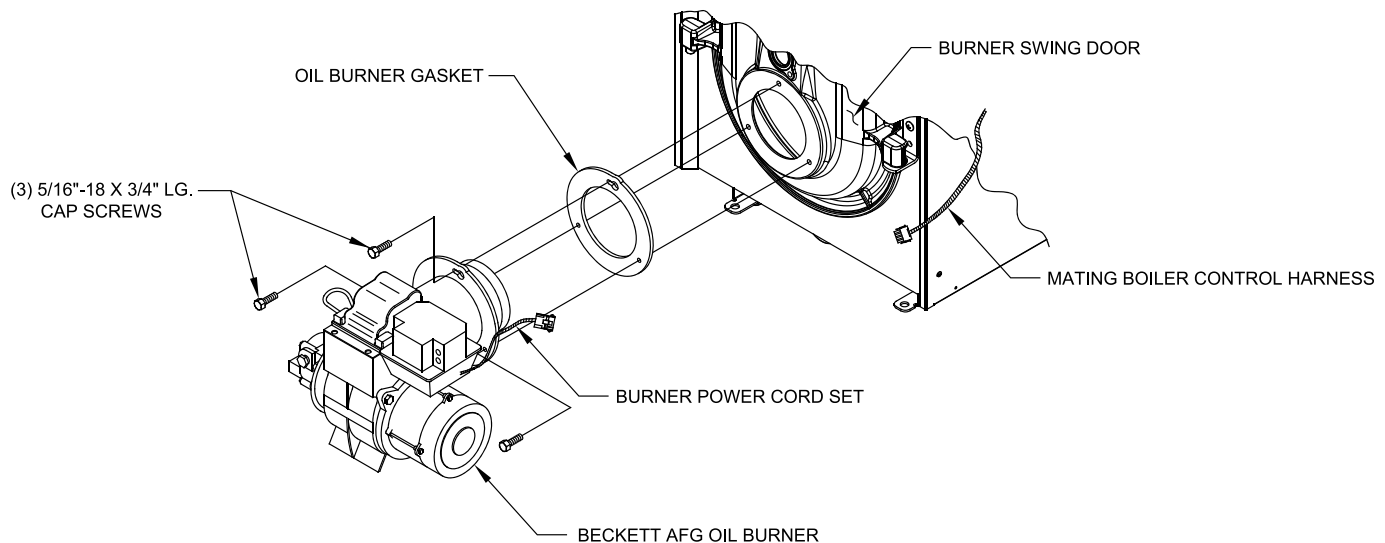

Figure 3-12: Oil Burner Installation (Beckett shown)

Table 3-13: Burner Cartons

Boiler Model	Burner Part Numbers	
	Beckett	Carlin
FWC-060	112312-01	106755-01
FWC-080	112313-01	106776-01
FWC-100	112314-01	106776-01
FWC-130	112315-01	106778-01
FWC-160	112987-01	112989-01

4 Water Boiler Piping

NOTICE: Failure to pipe boiler as specified in this manual may result in excessive system noise.

A. EVALUATE THE EXISTING WATER SYSTEM.

Design a piping system and install boiler which will prevent oxygen contamination of boiler water and frequent water additions.

1. There are many possible causes of oxygen contamination such as:
 - a. Addition of excessive make-up water as a result of system leaks.
 - b. Absorption through open tanks and fittings.
 - c. Oxygen permeable materials in the distribution system.
2. In order to insure long product life, oxygen sources must be eliminated. This can be accomplished by taking the following measures:
 - a. Repairing system leaks to eliminate the need for addition of make-up water.
 - b. Eliminating open tanks from the system.
 - c. Eliminating and/or repairing fittings which allow oxygen absorption.
 - d. Use of non-permeable materials in the distribution system.
 - e. Isolating the boiler from the system water by installing a heat exchanger.

CAUTION

Maintain minimum ½ inch clearance from hot water piping to combustible materials.

3. In order to insure long product life, operate boiler at appropriate flow rate to minimize areas of overheating.
 - a. Design system to ensure that the flow is above the limit called for in Table 4-1.
 - b. Maintain a constant boiler pressure of 12 PSI.

WARNING

Do not operate boiler below minimum volumetric flow rates.

WARNING

- Install boiler so that the electrical components are protected from water (dripping, spraying, rain, etc.) during appliance operation and service (circulator replacement, etc.)
- Operation of this boiler with continuous return temperatures below 120°F can cause severe heat exchanger corrosion damage.
- Operation of this boiler in a system having significant amounts of dissolved oxygen can cause severe heat exchanger corrosion damage.
- Do not use toxic additives, such as automotive antifreeze, in a hydronic system.
- Pipe pressure relief valve discharge to a safe location.
- Do not install any valves between boiler and pressure relief valve.
- Do not install any valves between pressure relief valve and discharge.
- Do not move pressure relief valve from factory specified location.
- Do not plug relief valve discharge. Blocking the relief valve may result in boiler explosion.

Table 4-1: Minimum Flow Rate

Boiler Model No.	Flow Rate (Gal / Min)
FWC-060	4.5
FWC-080	4.5
FWC-100	8.0
FWC-130	10.0
FWC-160	12.0

B. CONNECT SYSTEM SUPPLY AND RETURN PIPING TO BOILER. See Figures 4-2 and 4-3. Also, consult Residential Hydronic Heating Installation and Design I=B=R Guide RHH published by Air Conditioning Contractors of America (ACCA) for additional information on the design of hydronic heating systems.

1. If this boiler is used in connection with refrigeration systems, the boiler must be installed so that the chilled medium is piped in parallel with the heating boiler using appropriate valves to prevent the chilled medium from entering the boiler. See Figure 4-4. Also, consult Residential Hydronic Heating Installation and Design I=B=R Guide RHH published by Air Conditioning Contractors of America (ACCA) for additional information on the design of hydronic heating systems.

4 Water Boiler Piping (continued)

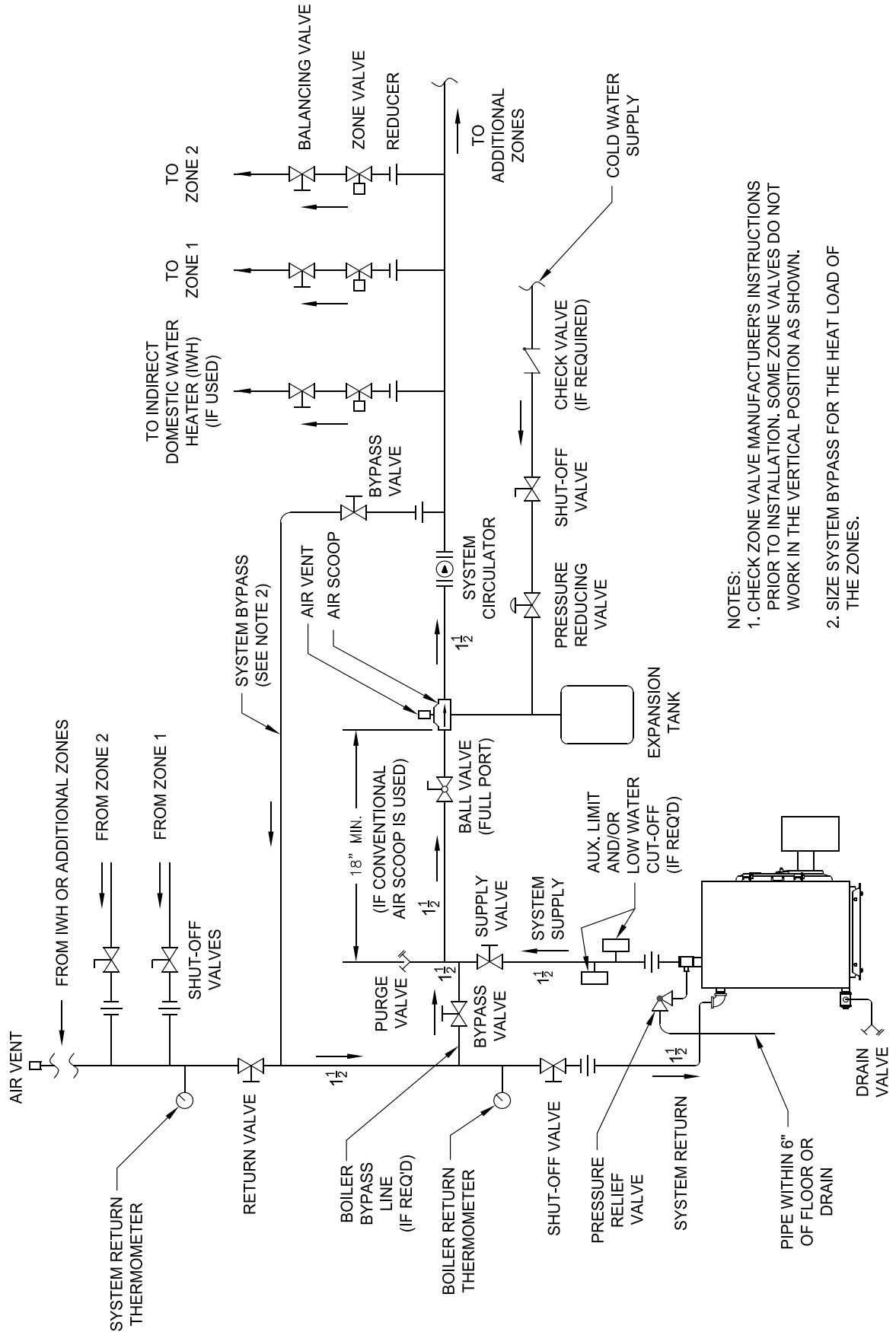

- NOTES:
1. CHECK ZONE VALVE MANUFACTURER'S INSTRUCTIONS PRIOR TO INSTALLATION. SOME ZONE VALVES DO NOT WORK IN THE VERTICAL POSITION AS SHOWN.
 2. SIZE SYSTEM BYPASS FOR THE HEAT LOAD OF THE ZONES.

LEFT SIDE VIEW

Figure 4-3: Recommended Water Piping for Zone Valve Zoned Heating Systems - Supply Side Circulator

4 Water Boiler Piping *(continued)*

2. If this boiler is connected to heating coils located in air handling units where they may be exposed to refrigerated air, the boiler piping must be equipped with flow control valves to prevent gravity circulation of boiler water during the operation of the cooling system.
3. If an indirect water heater is used, priority zoning can be used. Do not use priority zoning for Hydro-Air Systems. Refer to the Indirect Water Heater Installation, Operating, and Service Instructions for additional information.
4. The FWC is designed to withstand thermal shock from return water temperatures as low as 100°F, but prolonged return temperatures of below 135°F can cause excessive flue gas condensation and damage the boiler and/or venting system.

Use a boiler bypass if the boiler is to be operated in a system which has a large volume or excessive radiation where low boiler water temperatures may be encountered (i.e. converted gravity circulation system, etc.) The bypass should be the same size as the supply and return lines with valves located in the bypass and return line as illustrated in Figures 4-2 and 4-3 in order to regulate water flow for maintenance of higher boiler water temperature indication that the boiler contained trapped air.

5 Indirect Water Heater Piping

A. CONNECT INDIRECT DOMESTIC WATER HEATER PIPING as shown in Figure 5-1 and 5-2.

Also refer to Figures 4-2 and 4-3.

1. Refer to instructions furnished with Indirect Water Heater for additional information.

5 Indirect Water Heater Piping (continued)

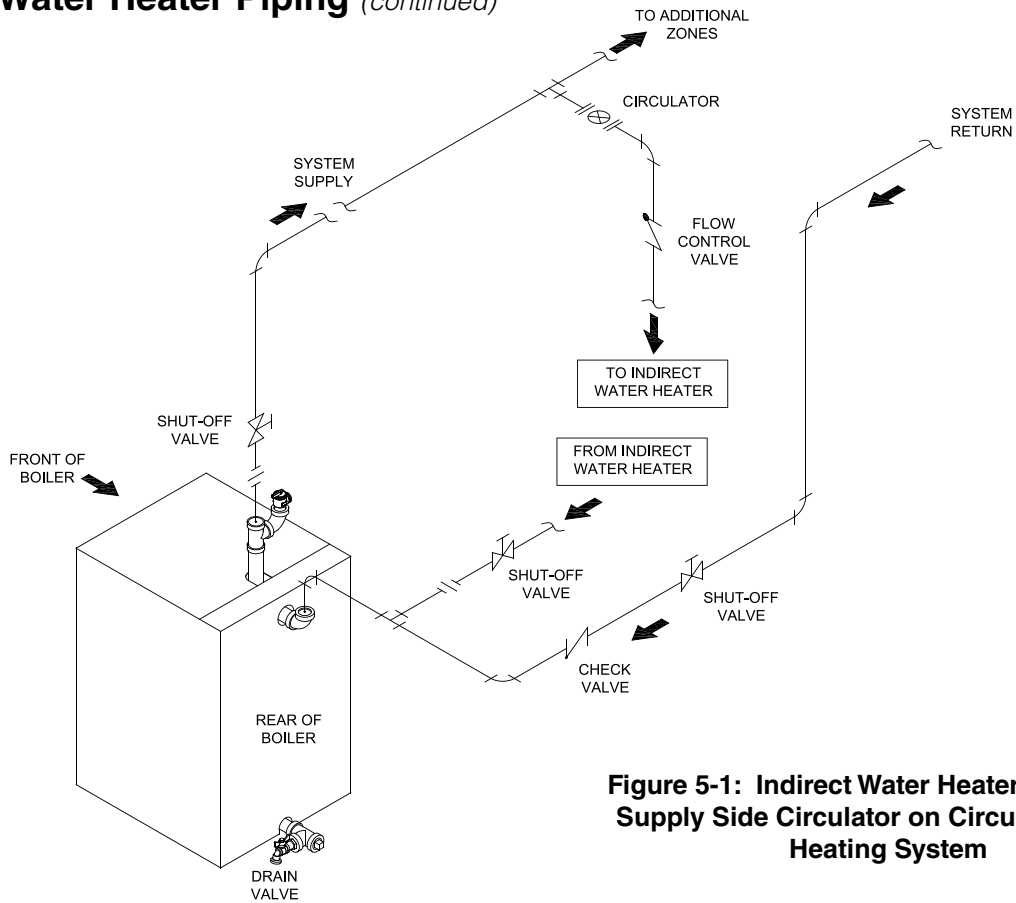

Figure 5-1: Indirect Water Heater Piping with Supply Side Circulator on Circulator Zoned Heating System

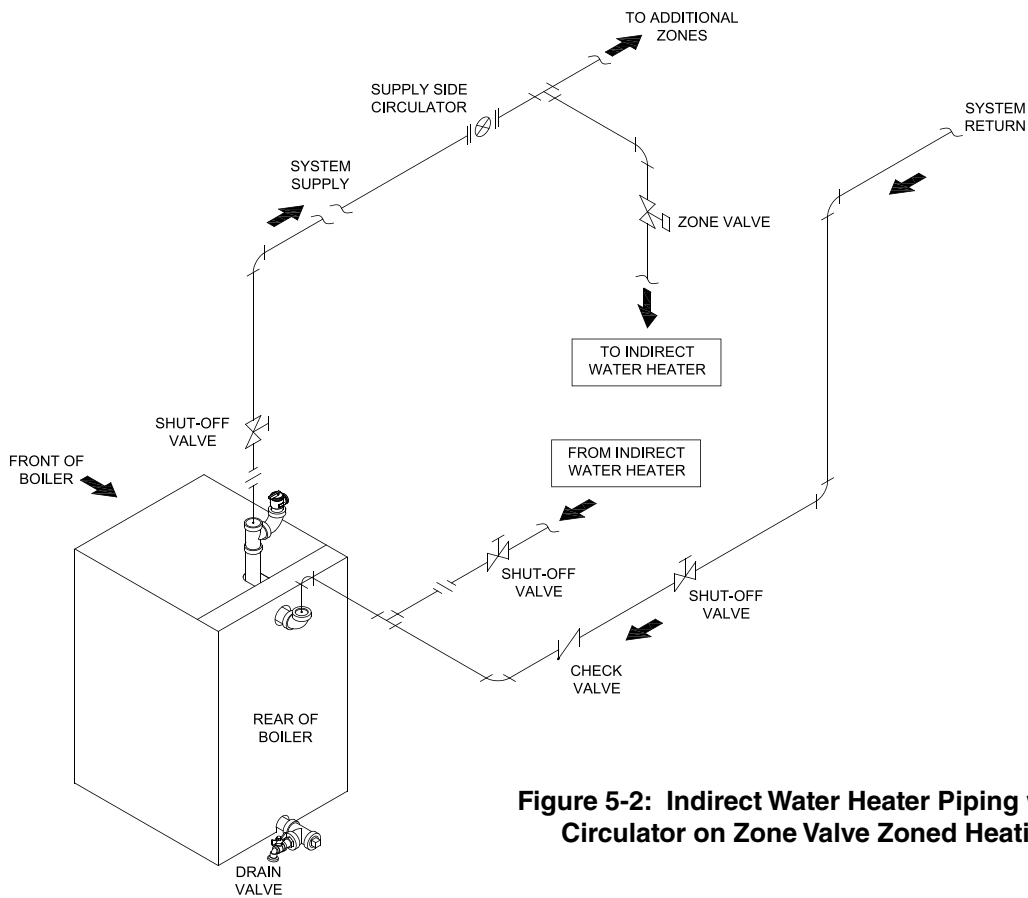

Figure 5-2: Indirect Water Heater Piping w/Supply Side Circulator on Zone Valve Zoned Heating System

6 Natural Draft Venting (Chimney)

WARNING

- Vent this boiler according to these instructions. Failure to do so may cause products of combustion to enter the home resulting in severe property damage, personal injury or death.
- Insufficient Combustion Air Supply may result in the production and release of deadly carbon monoxide (CO) into the home which can cause severe personal injury or death.
- Improper venting may result in property damage and the release of flue gases which contain deadly carbon monoxide (CO) into the home, which can cause severe personal injury, death, or substantial property damage.
- Inspect existing chimney and vent connector for obstructions and deterioration before installing boiler. Failure to clean or replace perforated pipe or chimney liner will cause severe injury or death.
- Do not de-rate the appliance. Failure to fire the boiler at its designed input may cause excessive condensation upon the interior walls of the chimney. In addition, the lower input may not create enough draft to adequately evacuate the products of combustion.

CAUTION

As with all oil-fired appliances, "Power Venting" this boiler creates a number of potential problems, especially when this is done through a side wall. These include but are not limited to:

- Accelerated rate of soot buildup on the oil burner cad-cell, burner head, and/or in the boiler itself.
- Odor complaints.
- Severe damage to the side of the structure in the event that the boiler operates at a high smoke level. These problems can occur for many reasons, some of which are out of the control of both the installer and the appliance manufacturer. The use of a chimney to vent this boiler is therefore recommended. If a power venter must be used, it is the responsibility of the installer and power venter manufacturer to "engineer" the power vent system.

THE BOILER MANUFACTURER WILL ASSUME NO RESPONSIBILITY FOR DAMAGE TO SIDING, ETC. FROM A POWER VENTING OIL-FIRED BOILER. THIS APPLIES REGARDLESS OF THE CAUSE OF THE SOOTING.

A. CHIMNEY VENTING

1. Chimney venting is an important part of a safe and efficient oil fired appliance system. Contact your local fire and building officials on specific requirements for restrictions and the installation of fuel oil burning equipment. In addition, consult with a professional knowledgeable on the requirements of NFPA 31 – Standard for the Installation of Oil-Burning Equipment and NFPA 211 - Standard for Chimneys, Fireplaces, Vents, and Solid Fuel-Burning Appliances for installations in the United States.
2. The safe venting of oil fired boilers is dependent on many factors. Some of these factors include:
 - a. Sufficient draft during the entire heating season to allow for the safe discharge of combustion by-products and;
 - b. Suitable corrosion protection in the event of condensing flue gases. Only a trained and qualified contractor may install this product.
3. The FWC shall be vented into any of the following:
 - a. Masonry or metal chimney. Build and install in accordance with local buildings codes; or local authority having jurisdiction; or "Standards for Chimney, Fireplace, Vents, and Solid Fuel Burning Appliances", ANSI/NFPA 211. Masonry chimney must be lined with listed chimney system. Listed clay flue lined masonry chimneys meet venting requirements.
 - External chimneys are more susceptible to flue gas condensation due to colder outside air temperatures. To prevent corrosion due to flue gas condensation, use a listed corrosion-resistant metal liner in chimney.
 - Oversized chimneys are more susceptible to flue gas condensation. To reduce the likelihood of flue gas condensation and ensure proper draft, use a properly sized listed metal liner in oversized chimney.
4. Chimney Inspection – Prior to the installation of any new or replacement fuel burning equipment the chimney shall be inspected by a qualified installer. The chimney shall be inspected for integrity as well as for proper draft and condensate control. Some jurisdictions require the use of a liner when changing fuel types. Some jurisdictions require the use of a liner even when the same fuel is used. At a minimum, the chimney shall be examined by a qualified person in accordance with the requirements of Chapter 11 of NFPA 211, Standard for Chimneys, Fireplaces, Vents, and Solid Fuel-Burning Appliances.

6 Natural Draft Venting (Chimney) *(continued)*

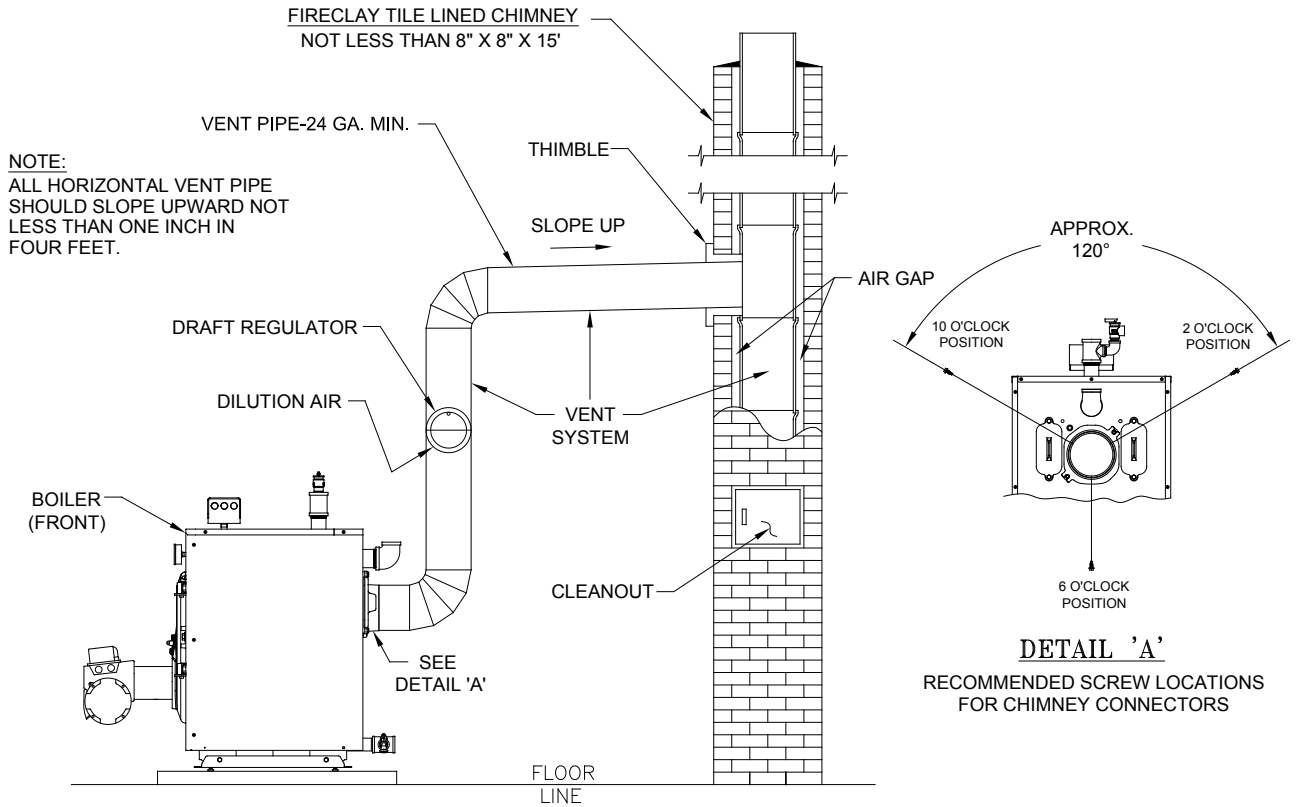

Figure 6-1: Recommended Vent Pipe Arrangement and Chimney Requirements

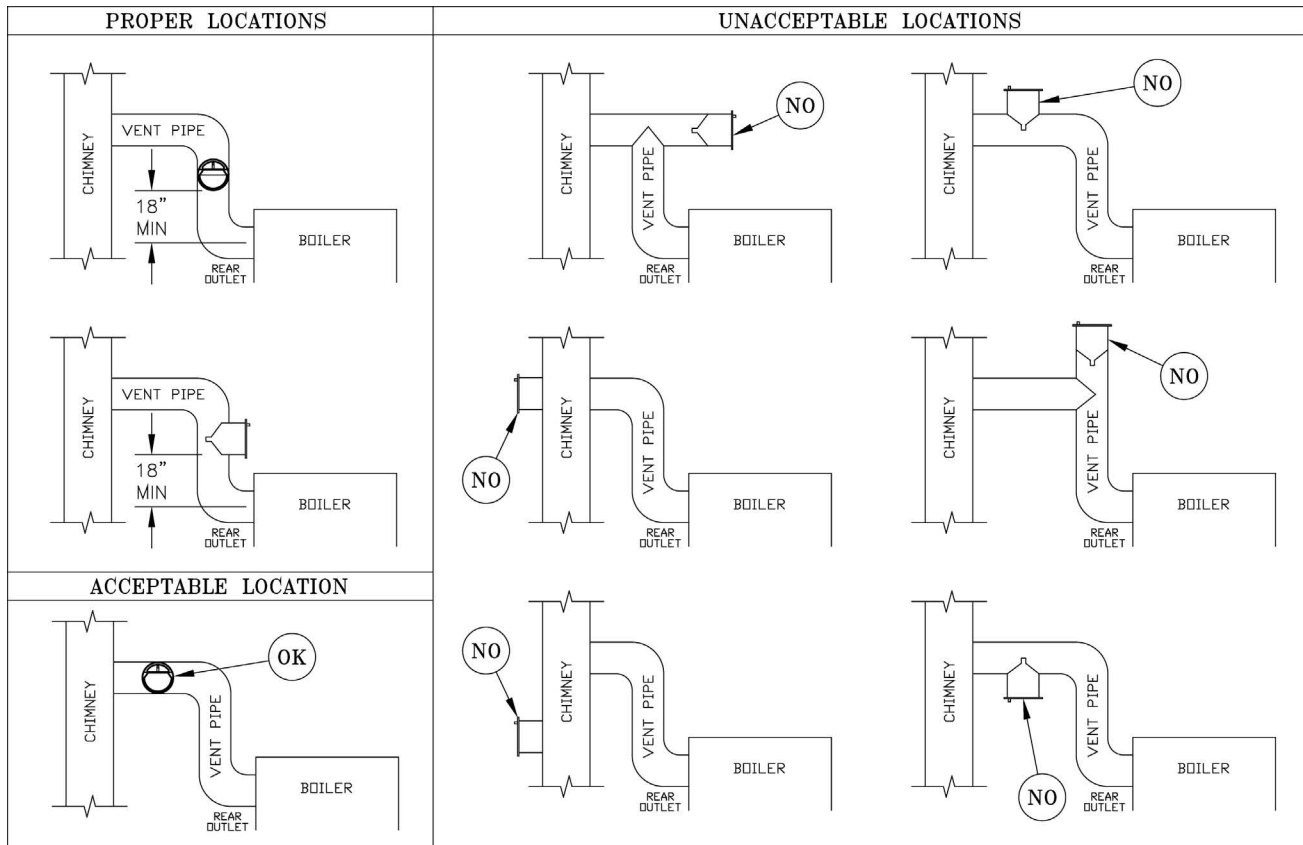

Figure 6-2: Proper and Improper Locations of Draft Regulator

6 Natural Draft Venting (Chimney) *(continued)*

- a. Loose Mortar – Loose mortar could be an indication of a prior history of condensing flue gases upon the inside walls of the chimney. Colder climates are more susceptible to this condition. Under no circumstances shall a chimney of this condition be used until it meets the requirements of NFPA 211.
 - b. Unlined Chimney – Under no circumstances shall a chimney constructed of brick only be used. Only approved clay liners or listed chimney lining systems shall be used as specified in NFPA 31.
 - c. Abandoned Openings – Openings through the chimney wall that are no longer used shall be sealed in accordance to NFPA 211. Often abandoned openings are improperly sealed and usually covered by a gypsum wall covering.
 - d. Clean Chimney – Chimney shall be free of all loose debris.
5. Draft Regulator – a draft regulator (supplied with boiler) must be used with this appliance. Refer to Figures 6-1 and 6-2.

B. CHIMNEY CONNECTOR

1. A chimney connector (vent pipe) is used to connect the boiler to the base of the chimney. The chimney connector should be kept as short as possible. The horizontal length of the chimney connector shall not be greater than 10 feet.

NOTE: Secure chimney connector to cast iron smokebox collar with three (3) #10 x ½ in. self drilling hex head TEK screws provided in miscellaneous parts carton. Locate screws around perimeter of connector as shown in Figure 6-3 and approximately ½ in. in from edge. Use drill with 5/16 in. hex bit to drive screws through connector and smokebox collar.

DANGER

The chimney and connector shall be inspected annually for signs of debris and corrosion. Loose mortar at the base of the chimney may be a sign of condensate damage to the chimney. A chimney professional shall be contacted immediately to examine the damage and recommend a solution. Long term operation while in this condition may cause a venting failure and force flue gases into the living space. If the chimney is to be re-lined use the recommendations in NFPA 31, Appendix E.

2. Vent Connector shall be any of the following and of the same size as the outlet of boiler.
 - a. Type L or a factory built chimney material that complies with the Type HT requirements of ANSI/UL 103. Install in accordance with listing and manufacturer's instructions.
 - b. Steel pipe having resistance to corrosion and heat with a minimum wall thickness of 24 Gauge (0.024 in.).

DANGER

Any signs of condensate seepage at the base of the chimney shall be inspected immediately. The discoloration may be a sign of chimney damage and must be remedied immediately.

C. DRAFT

1. The natural draft generated through a chimney is dependent on several factors including, chimney height, temperature of flue gases, cross section area of chimney, chimney wall insulation value, dilution air and total volume of flue gases, to name a few. Make sure that the boiler has been running for at least 5 minutes before measuring the draft.
2. Minimum Draft at Breech (Canopy) – The draft induced by a chimney must create at least a pressure of 0 (zero) inches water column (“w.c.”) at the pressure tapping on the canopy mounted on rear of boiler (see Figure 6-3). The pressure at the canopy cannot be positive since this could create a condition that allows flue gas by-products to escape from the draft regulator (not supplied). A negative pressure reading up to -.03 inches water column is acceptable for proper operation. (See Tables 15-1 and 15-2 Burner Specifications at the rear of this manual for more details)

6 Natural Draft Venting (Chimney) *(continued)*

D. STACK TEMPERATURE

1. The temperature of the flue gases has a significant effect on the amount of draft created in a vertical chimney as well as the propensity to create condensate. The higher the stack temperature, the greater the amount of draft that can be generated. A lower stack temperature not only reduces the amount of draft that can be created but it also increases the possibility that the flue gases could condense in the chimney connector or stack.
2. NFPA 31 has information to help the installer make an appropriate choice of venting materials. In some cases a chimney may have to be lined to create sufficient draft. In other cases, the chimney may have to be lined to prevent the corrosion of a masonry chimney. Consult with a chimney specialist knowledgeable on the requirements for chimney requirements in your area.

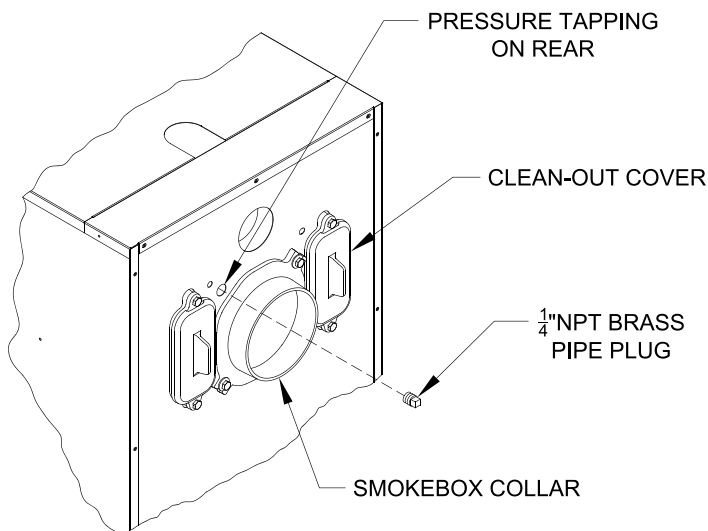

Figure 6-3: Smokebox Pressure Tapping for Checking Draft at Breach

⚠ CAUTION

Any doubt on the condition of a chimney or its ability to prevent the generation and accumulation of flue gas condensate, must be relined according to NFPA 31 (United States).

⚠ CAUTION

Use the chimney venting tables as a guide. It is highly recommended that any borderline application should result in the relining of the chimney with a suitable liner that creates sufficient draft and to protect against corrosion caused by flue gas condensate.

3. Baffles – The efficiency of the boiler is based on the insertion of flue baffles supplied with your product. Under no circumstances are other baffles to be used on this product. Refer to Section 3, Item F, Paragraph 6 for baffle installation. If there is any doubt on the application of this boiler on the intended chimney, consult with your local code officials. At a minimum, remove the baffles to increase the stack temperature. See Tables 15-1 and 15-2 for temperature differential (ΔT) with baffles IN and OUT. In addition, the lower the CO_2 level the higher the stack temperature.

⚠ WARNING

Remove the baffles if there are any signs of condensation in the chimney or chimney connector. Consult with your local chimney professional for recommendations.

E. MINIMUM CLEARANCES

See Figure 2-1 for details regarding clearances to combustibles for the boiler.

7 Electrical

DANGER

Positively assure all electrical connections are unpowered before attempting installation or service of electrical components or connections of the boiler or building. Lock out all electrical boxes with padlock once power is turned off.

WARNING

- Failure to properly wire electrical connections to the boiler may result in serious physical harm.
- Electrical power may be from more than one source. Make sure all power is off before attempting any electrical work.
- Each boiler must be protected with a properly sized fused disconnect.
- Never jump out or make inoperative any safety or operating controls.

A. GENERAL

1. Install wiring and electrically ground boiler in accordance with requirements of the authority having jurisdiction, or in absence of such requirements the *National Electrical Code*, ANSI/NFPA 70.
2. Refer to *National Electric Code* or Local Electric Codes for proper size and type of wire required. Follow Code.
3. A separate electrical circuit must be run from the main electrical service with an over-current device/disconnect in the circuit. A service switch is recommended and may be required by some local jurisdictions.
4. Use anti-short bushings on all wiring passing through boiler jacket, junction boxes and/or control boxes.
5. Use armored cable (BX) over all exposed line voltage wiring.
6. Wiring should conform to Figures 7-1 and 7-2.

- B. INSTALL A ROOM THERMOSTAT** on an inside wall about four feet above floor. Never install thermostat on an outside wall or where it will be influenced by drafts, hot or cold water pipes, lighting fixtures, television, rays of the sun or near a fireplace. Keep large furniture away from thermostat so there will be free movement of room air around this control.

Heat Anticipator in Thermostat should be set to match the requirements of the control to which it is connected. See Figures 8-1 and 8-2 for desired system and heat anticipator setting. If system tends to overheat above the thermostat's temperature setting, reduce heat anticipator setting by .1 or .2 amps. If system tends to short cycle without reaching desired room temperature, increase heat anticipator setting by .1 or .2 amps.

CAUTION

- When making voltage connections, make sure that no external power source is present in the thermostat circuits. If such a power source is present, it could destroy the boiler's control. One example of an external power source that could be inadvertently connected to the low voltage connections is a transformer in old thermostat wiring.
- Do not use the transformer provided on the boiler to power external devices such as zone valves. Doing so may cause damage to the transformer.

7 Electrical *(continued)*

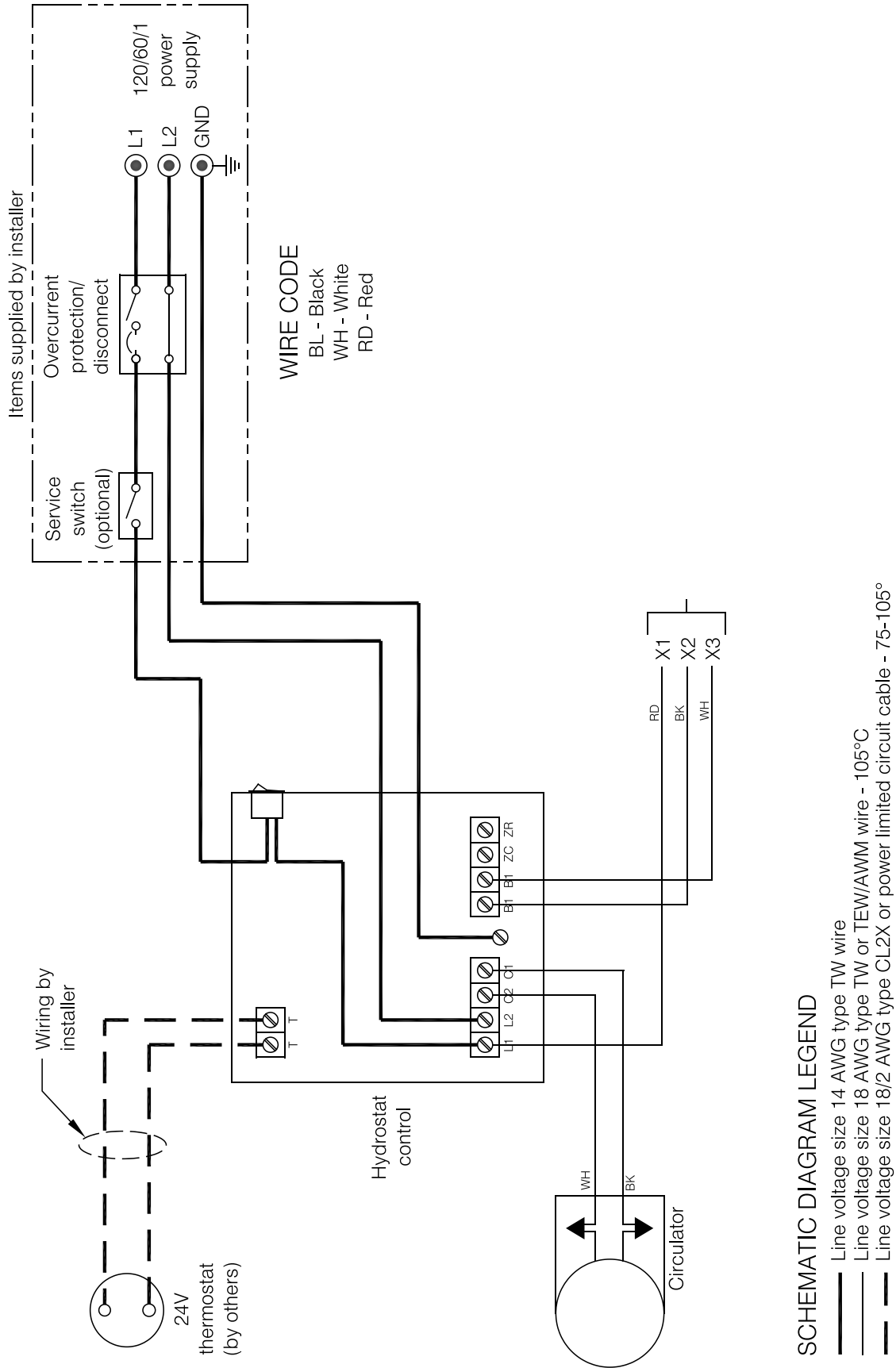
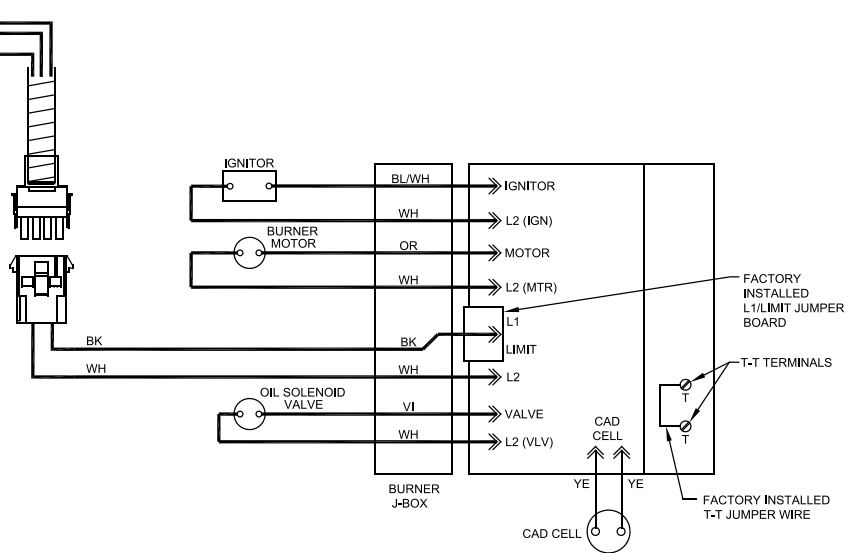

Figure 7-1: Schematic Wiring Diagrams HydroStat 3250 Control with All Burners

7 Electrical (continued)

NOTE: APPLY THIS BURNER SCHEMATIC TO APPROPRIATE WATER BOILER CONTROL SCHEMATIC,

NOTE: APPLY THIS BURNER SCHEMATIC TO APPROPRIATE WATER BOILER CONTROL SCHEMATIC,



BECKETT AFG BURNER WITH GeniSys OIL PRIMARY CONTROL

SCHEMATIC DIAGRAM LEGEND

- ⊙ SCREW TERMINAL
- QUICK CONNECT RECEPTACLE

WIRE COLORS

- BK - BLACK
- BL/WH - BLUE W/ WHITE TRACER
- WH - WHITE
- VI - VIOLET
- YE - YELLOW
- OR - ORANGE
- RD - RED

WIRE TYPE LEGEND

- LOW VOLTAGE FACTORY WIRING (SIZE 18 AWG, 105°C)
- LOW VOLTAGE FIELD WIRING
- LINE VOLTAGE FACTORY WIRING (SIZE 18 AWG, 105°C)
- LINE VOLTAGE FIELD WIRING

NOTES:

1. IF ANY ORIGINAL EQUIPMENT WIRE AS SUPPLIED WITH THE APPLIANCE MUST BE REPLACED, IT MUST BE REPLACED WITH WIRE HAVING THE SAME WIRE GAUGE (AWG), SAME WIRE TYPE, AND RATED FOR A MINIMUM OF 105°C.

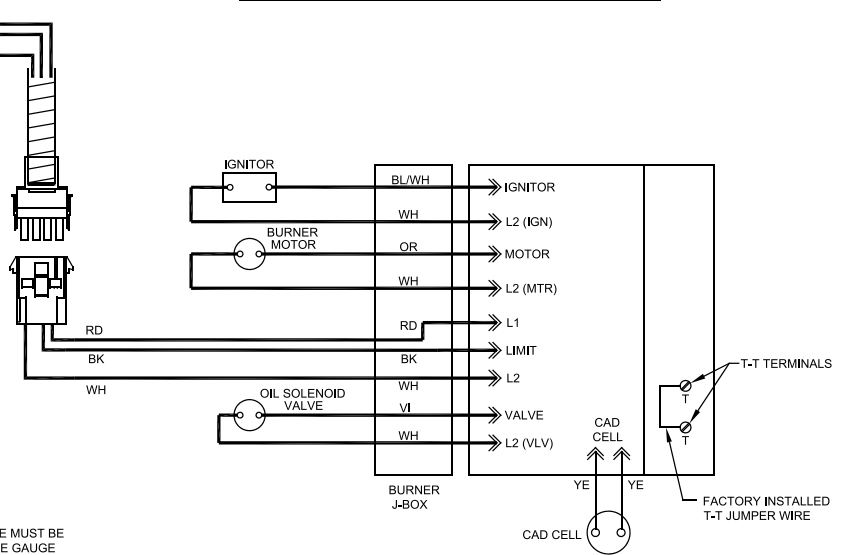

BECKETT NX BURNER WITH GeniSys OIL PRIMARY CONTROL

Figure 7-2: Schematic Wiring Diagrams For All Burners

8 Oil Piping

NOTICE: The National Oil Heat Research Alliance (NORA) recommends single pipe oil systems and high-quality filtration for all fuel types. This should include at least a 10-micron Spin-on filter. Double filtration provides even greater assurance clean fuel will get to the pump. Contaminants in the tank that enter the fuel supply to the burner can cause pump sticking/seizing. These contaminants may increase in the early stages of transitioning to modern fuels (Ultra Low Sulfur and Bio Blends). High quality filtration adds protection against pump sticking.

A. GENERAL

1. The use of a listed flexible oil line(s) so the burner swing door can be opened without disconnecting the oil supply piping is recommended.
2. A supply line fuel oil filter is recommended as a minimum for all firing rates but a pleated paper fuel oil filter is recommended for the firing rates below 1.0 GPH to prevent nozzle fouling.
3. Use Flared fittings only. Cast iron fittings cannot be used.
4. Do not use teflon tape for thread connectors. Use a listed, non-hardening thread sealant instead.

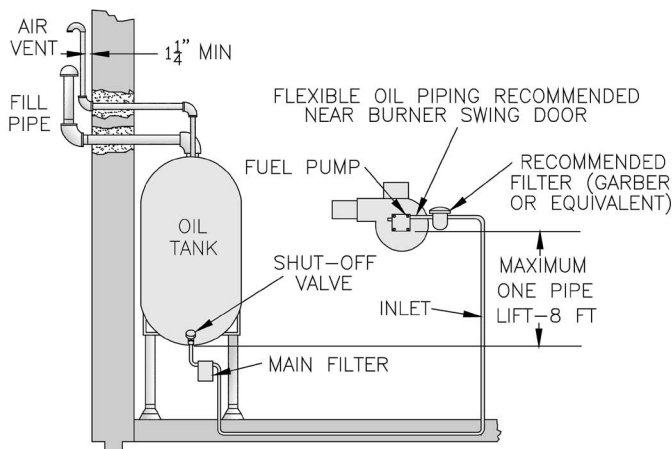

Figure 8-1: Single Pipe Oil Line

NOTICE: Do not use compression fittings.

Oil piping must be absolutely airtight or leaks or loss of prime may result. Bleed line and fuel unit completely.

Refer to your local jurisdictions regarding any special considerations for fuel supply requirements. In addition, refer to NFPA 31, *Standard for the Installation of Oil-Burning Equipment*.

5. Use of a high efficiency micron filter (Garber or equivalent) in addition to a conventional filter is highly recommended.
6. Piping used to connect the oil burner to the oil supply tank shall not be smaller than 3/8 in. iron pipe or 3/8 in. OD copper tubing. Copper tubing shall have a .032 in. minimum wall thickness.

WARNING

Under no circumstances can copper with sweat style connectors be used.

NOTICE: Some jurisdictions require the use of a fusible shutoff valve at the tank and/or the burner. In addition, some jurisdictions require the use of a fusible electrical interlock with the burner circuit. Check your local Codes for special requirements.

B. SINGLE PIPE OIL LINES

1. Standard burners are provided with single-stage 3450 RPM fuel units with the bypass plug removed for single-pipe installations.
2. The single-stage fuel unit may be installed single-pipe with gravity feed or lift. Maximum allowable lift is 8 feet. See Figure 8-1.
3. Fuel Oil Line Deaerator – On many occasions a leaky oil delivery line can introduce air into the fuel oil supply system. This often creates a rough starting condition and can create a burner lockout state. In addition to fixing the leak, a fuel line deaerator can be installed to eliminate air. The single line from the fuel tank is connected to the deaerator. The burner pump must be connected to the deaerator as a two pipe system. Follow the oil pump manufacturer's recommendations for conversion to a two pipe system.

8 Oil Piping (continued)

C. TWO PIPE OIL LINES

1. Follow the oil pump manufacturer's recommendations on the proper connections for a two pipe system. Some manufacturers require the insertion of a bypass plug.
2. Under no circumstances is a manual shutoff valve to be located on the return line of a two pipe system. Accidental closure of the return line will rupture the oil pump seals.

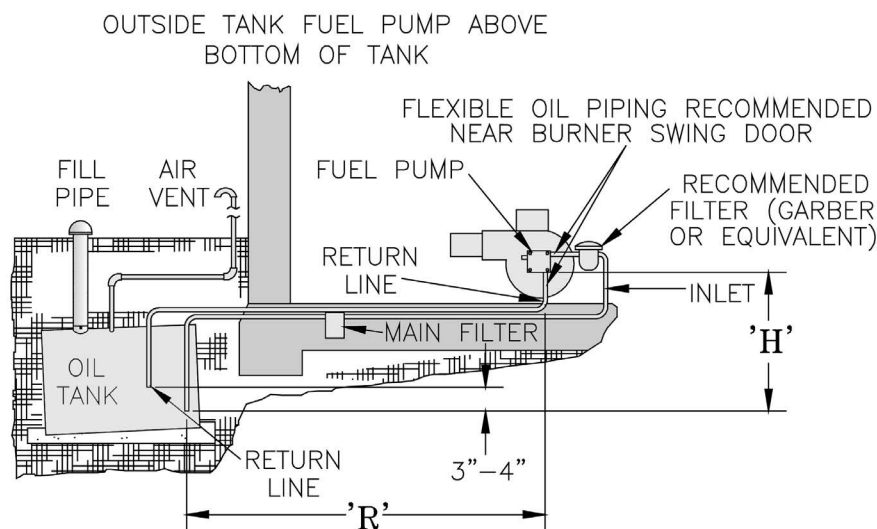

Figure 8-2: Two Pipe Oil Lines

9 System Start-Up

⚠ WARNING

All boilers equipped with burner swing door have a potential hazard which can cause severe property damage, personal injury or loss of life if ignored. Before opening swing door, turn off service switch to boiler to prevent accidental firing of burner outside the combustion chamber. Be sure to tighten swing door fastener completely when service is completed.

A. ALWAYS INSPECT INSTALLATION BEFORE STARTING BURNER.

1. Verify that the venting, water piping, oil piping, and electrical system are installed properly. Refer to Installation Instructions contained in this manual.
2. Confirm all electrical, water and oil supplies are turned off at the source and that the vent is clear from obstructions.

⚠ WARNING

Completely read, understand and follow all instructions in this manual before attempting start up.

NOTICE: The installer must verify that at least one carbon monoxide alarm has been installed within a residential living space or home following the alarm manufacturer's instructions and applicable local codes before putting the appliance into operation.

B. FILL HEATING SYSTEM WITH WATER.

1. **HOT WATER BOILERS.** Fill entire heating system with water and vent air from system. Use the following procedure on a series loop or multi-zoned system installed as per Figures 4-2 and 4-3, to remove air from system when filling:
 - a. Close full port ball valve in boiler system piping.
 - b. Isolate all zones by closing zone valves or shut-off valves in supply and return of each zone(s).
 - c. Attach a hose to vertical purge valve in boiler system supply piping up stream from the full port ball valve.

(Note - Terminate hose in five gallon bucket at a suitable floor drain or outdoor area).

9 System Start-Up *(continued)*

- d. Starting with one zone at a time, open zone valve or shut-off valve in boiler supply and return piping.
- e. Open purge valve.
- f. Open shut-off valve in cold water supply piping located between the air scoop and expansion tank.
- g. Allow water to overflow from bucket until discharge from hose is bubble free for 30 seconds.
- h. When zone valve is completely purged of air, close zone valve or shut-off valve. Open zone valve to the next zone to be purged. Repeat this step until all zones have been purged. At completion, open all zone valves.
- i. Close purge valve, continue filling the system until the pressure gauge reads 12 psi. Close shut-off valve in cold water supply piping.

WARNING

The maximum operating pressure of this boiler is posted on the ASME Data Label located on the top of the boiler. Never exceed this pressure. Do not plug relief valve.

NOTICE: If make-up water line is equipped with pressure reducing valve, system will automatically fill to 12 psi. Follow fill valve manufacturer's instructions.

- j. Open full port ball valve in boiler system piping.
- k. Remove hose from purge valve.
- l. Confirm that the boiler and system have no water leaks.

C. CHECK CONTROLS, WIRING AND

BURNER to be sure that all connections are tight and burner is rigid, that all electrical connections have been completed and fuses installed, and that oil tank is filled and oil lines have been tested.

D. ADJUST CONTROL SETTINGS

- with burner service switch turned "ON".
1. SET ROOM THERMOSTAT about 10°F below room temperature.
 2. Refer to instructions supplied with burner to reset primary control.

3. CHECKOUT

Put the system into operation and observe at least one complete cycle to make sure that the controller operates properly. See Troubleshooting Section to use LED to assist in determining system operation.

E. CHECK / ADJUST OIL BURNER BEFORE STARTING.

1. CHECK BURNER SETTINGS and readjust if necessary, see Burner Specifications, Tables 15-1 and 15-2 at the rear of this manual.

F. START OIL BURNER.

1. Open vent fitting on fuel pump.
2. TURN 'ON' BURNER service switch and allow burner to run until oil flows from vent fitting in a SOLID stream without air bubbles for approximately 10 seconds.
3. Close vent fitting and burner flame should start immediately after prepurge is completed. Prepurge prevents burner flame until 15 seconds has elapsed after initial power is applied to burner. During prepurge the motor and igniter will operate but the oil valve will remain closed. Refer to Oil Primary Control Instructions for more details.
4. Adjust oil pressure.
 - a. Install 0-200 psi pressure gauge into oil pump gauge port. Refer to the burner manufacturer's instructions.
 - b. Locate oil pressure adjusting screw and turn screw to obtain proper pump pressure, refer to Tables 15-1 and 15-2 at the rear of this manual.
 - c. To check the cut-off pressure, deadhead a reliable pressure gauge onto the copper connector tube attached to the nozzle port. Run the burner for a short period of time. Shut the burner off. The pressure should drop and hold.
 - d. Remove the gauge and install bleeder port and/or reconnect the nozzle port line.

G. ADJUST OIL BURNER WHILE OPERATING. (flame present)

1. Set room thermostat about 10°F above room temperature.
2. ADJUST DRAFT REGULATOR for a draft of zero inches (water gauge) in the flue collector (see Figure 6-3) after chimney has reached operating temperature and while burner is running. (At least five minutes)

9 System Start-Up *(continued)*

See Tables 15-1 and 15-2 at the rear of this manual for additional details.

3. READJUST THE AIR DAMPER SETTING (Air Band/Air Shutter/Air Gate) on burner for a light orange colored flame while the draft in the flue collector is zero inches water column ("w.c.). Use a smoke tester and adjust air for minimum smoke (not to exceed #1) with a minimum of excess air. Make final check using suitable instrumentation to obtain a CO₂ of 11.5 to 13.0% with draft of zero inches water column ("w.c.) (water gauge) in flue collector. These settings will assure a safe and efficient operating condition. If the flame appears stringy instead of a solid fire, try another nozzle of the same type. Flame should be solid and compact. After all adjustments are made recheck for a draft of zero inches water column ("w.c.) in the flue collector. Replace plug at completion.

See Tables 15-1 and 15-2 (at the rear of this manual) for details regarding the overfire pressure when baffles are both installed and removed.

NOTE: Paragraph G, Step 1 **MUST BE** repeated every time the Air Setting is readjusted.

WARNING

DO NOT loosen or remove any oil line fittings while burner is operating.

4. FLAME FAILURE

The FWC boiler controls operate the burner automatically. If for unknown reasons the burner ceases to fire and the reset button on the primary control has tripped, the burner has experienced ignition failure. Refer to Oil Primary Control features, Paragraph I, Step 2 of this section and Section 14, Troubleshooting, Paragraph B. If the failure re-occurs, call your heating contractor immediately before pressing the reset button.

WARNING

DO NOT attempt to start the burner when excess oil has accumulated, when the boiler is full of vapor, or when the combustion chamber is very hot.

H. CHECK FOR CLEAN CUT OFF OF BURNER.

1. AIR IN THE OIL LINE between fuel unit and nozzle will compress when burner is on and will expand when burner stops, causing oil to squirt from nozzle at low pressure as burner slows down and causing nozzle to drip after burner stops. Usually cycling the burner operation about 5 to 10 times will rid oil line of this air.
2. IF NOZZLE CONTINUES TO DRIP, repeat Paragraph H, Step 1 above. If this does not stop the dripping, remove cut-off valve and seat, and wipe both with a clean cloth until clean, then replace and readjust oil pressure. If dripping or after burn persist replace fuel pump.

I. TEST CONTROLS.

1. Check thermostat operation. Raise and lower thermostat setting as required to start and stop burner.

WARNING

Before installation of the boiler is considered complete, the operation of all boiler controls must be checked, particularly the primary control and high limit control.

2. VERIFY OIL PRIMARY CONTROL

2. **FEATURES** using procedures outlined in Instructions furnished with the burner.
3. Check high limit control operation. Jump thermostat terminals and allow burner to run until boiler water temperature exceeds high limit setting. The burner should shut down, and circulator continue running. Allow the temperature to drop below the control setting. The burner must restart. Boiler installation is not complete unless these checks are made and are satisfactory. Remove thermostat jumper and reconnect thermostat upon check completion.
4. After the boiler has operated for approximately 30 minutes, check the boiler and heating system for leaks. Repair any leaks found at once.
5. After the above checks have been completed, leave thermostat(s) at desired setting. Leave all instructions provided with the boiler with owner or in boiler room, displayed near boiler.

10 Operating

A. HydroStat 3250 PLUS SEQUENCE OF OPERATION

IMPORTANT This boiler is equipped with a feature that saves energy by reducing the boiler water temperature as the heating load decreases.

This feature is equipped with an override which is provided primarily to prevent the use of an external energy management system that serves the same function. THIS OVERRIDE MUST NOT BE USED UNLESS AT LEAST ONE OF THE FOLLOWING CONDITIONS IS TRUE:

- An external energy management system is installed that reduces the boiler water temperature as the heating load decreases.
- This boiler is not used for any space heating.
- This boiler is part of a modular or multiple boiler system having a total input of 300,000 BTU.HR or greater.
- This boiler is equipped with a tankless coil.

1. Setting the Control

- a. Setting the High Limit: The high limit is factory set at 190°F. To adjust, turn the HI TEMP Dial A until the desired setting is displayed. (Setting range: 100°-220°F).
- b. Setting the low limit: Low limit must be set to "OFF".
- c. Setting the Economy Feature: The Economy Feature is factory set for a 1 zone heating system. To adjust, turn the ECONOMY Dial D until the number displayed equals the number of heating zones. Do not include indirect water heaters in the number of heating zones. The Economy Feature conserves fuel by reducing boiler temperature (see "How Thermal Targeting Works").

If the heating system is unable to supply needed heat to the house, the ECONOMY Dial should be turned lower setting (example: In a three zone house, turn the dial to 2 or 1.) Conversely, if the boiler provides adequate heat, added fuel savings can be achieved by selecting a higher setting (example: 4 or 5). If the heating and indirect water heater signals were not separated when wiring the control, the Economy Feature should be turned OFF to ensure the boiler supplies adequate temperature to heat the indirect tank.

- d. Setting the Zone/Indirect Switch: See WIRING.

SETTING	
OFF	Disables economy function. Will allow boiler to fire until hi-limit temp is reached and re-fire with a 10° subtractive differential
LO	Provides lowest level of fuel savings. Use this setting only if the house does not stay warm at higher settings.
1	Recommended setting for single zone systems
2	Recommended setting for Two zone systems
3	Recommended setting for Three zone systems
4	Recommended setting for Four zone systems
5	Recommended setting for Five zone systems
HI	Provides highest level of fuel savings

- e. Optional Features: NOTE: The program Mode-Pro - is accessed by turning the LP TEMP dial to position just above Off.
2. Thermal Pre-Purge: Thermal Pre-Purge is designed to maximize boiler efficiency. When activated, the control will supply latent heat that may remain in the boiler from a previous run cycle to the heating zone that is now calling. The control monitors how quickly the boiler temperature is declining and activates the burner only when it determines that the latent heat is insufficient to satisfy the call. During the purge cycle, the display will indicate Pur. This feature works with single-zone and multi-zone heating systems utilizing circulators or zone valves. No change in wiring is needed.

To activate Thermal Pre-Purge:

- Turn the LO TEMP dial to access the Program Mode - indicated in the display as Pro.
- Turn the HI TEMP dial to select feature 1.
- Push the Test/Setting Button to turn Thermal Pre-Purge ON or OFF.
- Reset LO TEMP and HI TEMP settings to desired temperatures.

3. Degrees Fahrenheit or Celsius: The control has the ability to operate in degrees Fahrenheit or Celsius. When operating in Celsius, a c will appear in the display next to the temperature whenever the temperature is below 100 degrees.

To change between degrees Fahrenheit and degrees Celsius:

- Turn the LO TEMP dial to access the Program Mode - indicated in the display as Pro.
- Turn the HI TEMP dial to select feature 2.
- Push the Test/Setting Button to c for Celsius or F for Fahrenheit.

10 Operating *(continued)*

- Reset LO TEMP and HI TEMP settings to desired temperatures.
4. Manual Reset Low Water Cut-Off:
The low water cut-off operation on the HydroStat can be set to operate in automatic (default) or manual reset mode. When in manual reset mode, the control will shut-down the burner immediately when low water condition is detected. If the low water condition is sustained for 30 seconds, the low water light will blink, indicating that the control has locked out the burner. The control can only be reset by pushing the Test Settings button on the top of the control. The manual reset feature meets CSD-1 code requirements.

IMPORTANT: The system must be checked by a qualified heating professional prior to resuming operation.

WARNING: DO NOT ADD WATER UNTIL THE BOILER HAS FULLY COOLED.

To activate Manual Reset LWCO mode:

- Turn the LO TEMP dial to access the Program Mode - indicated in the display as Pro
- Turn the HI TEMP dial to select feature 3
- Push the Test/Setting Button to A for Automatic Reset Mode
- Reset LO TEMP and HI TEMP settings to desired temperatures.

To Test the Manual Reset Feature: Press and hold the Test/Settings button located on the top of the control for 30 seconds to simulate a low water condition. After 30 seconds, the Low Water light will blink indicating that the control is locked out. To reset the lock-out condition, press the Test/Setting button momentarily.

5. Circulator Activation Options
When in the default mode, the HydroStat activates the circulator (**C1/C2** contacts) on calls to **TT**. The control can be programmed to activate the circulator on calls to **ZC/ZR** in place of, or in addition to **TT**.

To change how the Circulator is activated:

- Turn the LO TEMP dial to access the Program Mode - indicated in the display as Pro.
 - Turn the HI TEMP dial to select feature 4.
 - Push the Test/Setting Button to select between the following options:
A - Circulator on **TT** call only
b - Circulator on **ZC/ZR** calls
C - Circulator on both **TT** & **ZC/ZR** calls
 - Reset LO TEMP and HI TEMP settings to desired temperatures.
 - Push the Test/Setting Button to select between the following options:
A - Circulator on **TT** call only
b - Circulator on **ZC/ZR** calls
C - Circulator on both **TT** & **ZC/ZR** calls
 - Reset LO TEMP and HI TEMP settings to desired temperatures.
6. Circulator Hold Off (Enhanced Condensing Protection) Do not activate this feature.

10 Operating *(continued)*

7. High Limit Differential

When the Economy feature is on, the control's Thermal Targeting feature actively sets varying differentials based on system conditions. This option allows for selecting a 10, 20 or 30 degree fixed differential when the Economy feature is turned OFF. These optional differential settings are subtractive from the HIGH LIMIT setting. **Note:** If the Economy feature is on, this setting will be overridden by the control's Thermal Targeting function.

To change the high limit differential:

- Turn the LO TEMP dial to access the Program Mode - indicated in the display as Pro.
- Turn the HI TEMP dial to select feature 9.
- Push the Test/Setting Button to select a high limit differential of 10, 20, or 30.

8. Restore Factory Default Settings

To restore all features to the factory default settings (see following chart for default settings):

- a. Turn the LO TEMP dial to access the Program Mode - indicated in the display as Pro
- b. Turn the HI TEMP dial to select feature dEF
- c. Push the Test/Setting Button to Y to reset all features to the default settings
- d. Reset LO TEMP and HI TEMP settings to desired temperatures.

9. LED Legend and Test/Settings Button

- a. TEMP ACTIVE Indicates that the Fuel Smart HydroStat control is powered and that the temperature function is active.
- b. TEMP HI TEMP Illuminates when the boiler water temperature reaches the high limit setting. It will remain lit until the water temperature falls 10°. The Fuel Smart HydroStat prevents burner operation while this LED is on. See Differential explanation.

- c. LWCO ACTIVE Indicates that the low water cut-off (LWCO) function of the Fuel Smart HydroStat is active. When the control is installed with a Hydrolevel Electro-Well™, this LED will be on at all times when the control is powered. **IMPORTANT:** If the control is installed with a well other than the Electro-Well™, this LED will now illuminate indicating that the control is not providing low water cut-off functionality.
- d. LWCO LOW WATER Indicates that the boiler is in a low water condition. The HydroStat control will prevent burner operation during this condition. If the LOW WATER light is blinking, the control has been programmed to provide lockout protection in the event a low water condition is detected (see Manual Reset Low Water Cut-Off). Pressing the TEST/SETTINGS button will reset the control.

IMPORTANT: The system must be checked by a qualified heating professional prior to resuming operation.

WARNING

Allow the boiler to fully cool before adding water.

- e. ECONOMY ACTIVE Indicates that the Thermal Targeting function is active and the Fuel Smart HydroStat will reduce boiler temperature to conserve fuel. The Economy feature is activated using the ECONOMY dial. (See "How Thermal Targeting Works" for more information).
- f. ECONOMY TARGET When the Economy feature is active, the Fuel Smart HydroStat continually sets target temperature below the high limit setting to maximize fuel efficiency. When the boiler water reaches the target temperature, the LED illuminates and the burner will shut down. The boiler water will continue to circulate and heat the house as long as the thermostat call continues. The LED will stay lit until the boiler temperature drops below the differential set point at which point the boiler will be allowed to fire again. See Differential explanation.

NOTE: This LED illuminates regularly during normal boiler operation.

10 Operating *(continued)*

- g. TEST/TESTING Button
To Test Low Water Cut-Off: Press and hold the Test/Settings button for 5 seconds. The display will read LCO.

LWCO TEST LCO

The red Low Water light should illuminate and the burner circuit (B1 and B2) should de-energize.
 NOTE: The control must be installed with a Hydrolevel Electro-Well™ for low water cut-off functionality.

To View Current Settings: Press and release the Test/Settings Button in short intervals to sequentially display the following settings:

HIGH LIMIT SETTING HL



LOW LIMIT SETTING LL



ECONOMY SETTING ECO



CURRENT TARGET TEMPERATURE 000

The display will return to boiler temperature (default) if Test/Settings Button is not pressed for 5 seconds.

B. PRIMARY CONTROL

Refer to instructions supplied with Burner.

Dial Setting	Feature	Options	Description	Default Setting
1	Thermal Pre-Purge	OFF ON	Purge Inactive Purge Active	OFF
2	Fahrenheit or Celsius	F C	Degrees Fahrenheit Degree Celsius	F
3	LWCO Manual or Automatic Reset	A b	Automatic Reset Manual Reset	A
4	Circulator Options	A b c	Circulator operation on TT call only Circulator operation on ZC/ZR call only Circulator operation on call from either	A
5	Circulator Hold Off	ON OFF	Circulator Hold Off - Active Circulator Hold Off - Inactive	OFF
6	Not available on this control			
7	Not available on this control			
8	Well Type	A b	Hydrolevel Electro-Well Standard Immersion Well	A
9	High Limit Differential	10 20 30	10° Differential 20° Differential 30° Differential	10
dEF	Restore Factory Defaults	Y N	Restore Defaults Do Not Restore Defaults	n

11 Maintenance and Service Instructions

A. MAINTENANCE OF LOW WATER CUT-OFF DEVICES

WARNING

Probe and float type low water cut-off devices require annual inspection and maintenance.

1. PROBE TYPE LOW WATER CUT-OFF

Although these devices are solid state in their operation, the probe is exposed to possible contamination in the boiler water and subject to fouling.

It is important to physically remove the probe from the boiler tapping annually and inspect that probe for accumulation of scale or sediment.

Follow these steps to inspect, clean and/or replace the probe:

- a. Turn off electric service to the boiler.
- b. Drain boiler water to a level below the tapping for the probe.
- c. Disconnect wiring connections between the low water cut-off control and the probe.
- d. Remove the low water cut-off control from the probe.

DANGER

Assure that the boiler is at zero pressure before removing the LWCO probe. **DO NOT** rely on the pressure gauge to indicate that the boiler is at zero pressure. Open the Pressure Relief Valve to relieve all internal pressure prior to proceeding. Pressure Relief Valve discharge piping must be piped such that the potential for burns is eliminated.

- e. Unscrew the probe from the boiler tapping.
- f. Inspect that portion of the probe that is exposed to the boiler water for a scale or sediment buildup.
- g. Light deposits may be removed by wiping the probe with a damp cloth. Wiping the probe with a cloth soaked in vinegar will remove more tenacious lime deposits. The most stubborn deposits may be removed from the probe by using a diluted amount, 3 parts of water to 1 part of phosphoric acid (H_2PO_4).

CAUTION

Exercise caution when handling phosphoric acid and follow the instruction label on its container.

- h. Clean the pipe threads of the probe to remove old, hardened pipe dope and other foreign matter.
- i. Apply a moderate amount of good quality pipe dope to the pipe threads on the probe, leaving the two end threads bare. **DO NOT** use PTFE (Teflon) tape.
- j. Screw the probe into the boiler tapping.
- k. Mount the low water cut-off control on the probe.
- l. Reconnect the control to probe wiring.
- m. Fill the boiler to its normal waterline.
- n. Add boiler water treatment compound as needed (refer to Paragraph B.).
- o. Restore electric service to the boiler.
- p. Fire burner to bring the water in the boiler to a boil to drive off free oxygen.
- q. **WARNING — BEFORE RETURNING BOILER TO SERVICE:** Follow the low water cut-off check out procedure.

B. BOILER AND SYSTEM CLEANING INSTRUCTIONS FOR TROUBLE FREE OPERATION

NOTICE: Check with local authorities or consult local water treatment services for acceptable chemical cleaning compounds.

1. WATER BOILERS

- a. *Filling of Boiler and System — General* — In a hot water heating system, the boiler and entire system (other than the expansion tank) must be full of water for satisfactory operation. Water should be added to the system until the boiler pressure gauge registers 12 psi. To insure that the system is full, water should come out of all air vents when opened.

11 Maintenance and Service Instructions *(continued)*

C. EXCESSIVE MAKE-UP WATER

A leaky system will increase the volume of make-up water supplied to the boiler which can significantly shorten the life of the boiler. Entrained in make-up water are dissolved minerals, salts and oxygen. When the fresh, cool make-up water is heated in the boiler the minerals fall out as sediment, the salts coat the inside of the boiler, and the oxygen escapes as a gas. The accumulation of sediment eventually isolates the water from contacting the cast iron. When this happens the cast iron in that area gets extremely hot and eventually cracks. The presence of free oxygen or chloride salts in the boiler corrodes the cast iron from the inside. More make-up water and higher concentrations of contaminants damage the boiler sooner. **Our warranty does not cover corrosion and sediment-related damage.**

D. ATTENTION TO BOILER WHILE NOT IN OPERATION

NOTICE: If boiler is not used during winter time, it must be fully drained to prevent freeze damage.

1. Spray inside surfaces with light lubricating or crankcase oil using gun with extended stem so as to reach all corners.
2. Always keep the manual fuel supply valve shut off if the burner is shut down for an extended period of time.
3. To recondition the heating system in the fall season after a prolonged shut down, follow the instructions outlined in Section 9, Paragraphs A through K.

WARNING

This boiler contains controls which may cause the boiler to shut down and not restart without service. If damage due to frozen pipes is a possibility, the heating system should not be left unattended in cold weather; or appropriate safeguards and alarms should be installed on the heating system to prevent damage if the boiler is inoperative.

12 Boiler Cleaning

Important Product Safety Information: Refractory Ceramic Fiber Product

WARNING

Some boiler components use materials that contain refractory ceramic fibers (RCF). RCF has been classified as a possible human carcinogen. When exposed to elevated temperatures, RCF may change into crystalline silica, a known carcinogen. When disturbed as a result of servicing or repair, these substances become airborne and, if inhaled, may be hazardous to your health. Avoid breathing RCF particulates and dust.

Precautionary Measures:

- Do not handle RCF parts or attempt any service or repair work involving RCF without wearing the following protective gear:
 1. A properly fitting National Institute for Occupational Safety and Health (NIOSH)-certified air-purifying respirator with a filter efficiency of at least 95%. Respirator should also include a full facepiece when handling used RCF. Other types of respirators may be required depending on site conditions. Current NIOSH recommendations may be found on the NIOSH website <http://www.cdc.gov/niosh/index.html>. NIOSH-approved manufacturers, respirators and associated user instructions are listed on the NIOSH website.
 2. Long sleeved, loose fitting clothing that is sufficiently tight around potential entry points for RCF dust.
 3. Gloves.
 4. Eye protection, such as goggles, safety glasses with side shields, or full facepiece.
- Take steps to assure adequate ventilation.
- Handle RCF carefully to minimize airborne dust. Use hand tools whenever possible.
- Dampen used RCF with light water spray prior to removal to prevent airborne dust.
- Do not use compressed air or dry sweeping for clean-up. Frequently clean work area with a vacuum or by wet sweeping to minimize debris accumulation.
- Vacuum work clothes before leaving work area. Wash work clothes separately from other laundry and rinse washing machine after use to avoid contaminating other clothes.
- Wash all exposed body areas gently with soap and water after contact.
- Discard used RCF components by sealing in an airtight plastic bag or container. Refer to local, regional, state or provincial regulations to identify applicable disposal requirements.

First Aid Procedures:

- Eye contact: Flush with water for at least 15 minutes. **Do not rub eyes.** Seek immediate medical attention if irritation persists.
- Skin contact: Wash affected area gently with soap and water. Do not rub or scratch affected skin. Seek immediate medical attention if irritation persists.
- Nose and throat contact: If these become irritated, leave the area and move to a location with clean fresh air. Drink water and blow nose. Seek immediate medical attention if symptoms persist.

112645-01

12 Boiler Cleaning *(continued)*

WARNING

All boiler cleaning must be completed with burner service switch turned off. Boilers equipped with burner swing door have a potential hazard which can cause severe property damage, personal injury or loss of life if ignored. Before opening swing door, turn off service switch to boiler to prevent accidental firing of burner outside the combustion chamber. Disconnect the burner plug from the receptacle in the front jacket. Be sure to tighten swing door fastener completely when service is completed.

A. CLEAN THE FLUEWAYS (See Figure 12-1).

1. For access to the combustion chamber remove the two (2) 3/8 in. - 16 cap screws. If boiler is equipped with flexible fuel line(s), swing door open.
2. Remove the two smoke box clean-out covers from the rear smoke box by removing the four 5/16 in.-18 hex head bolts. It is NOT necessary to remove the vent connector from the smoke box to clean boiler.
If necessary, remove the vent connector if there is evidence of heavy soot accumulation in the boiler or to inspect base of chimney for condensate or accumulation of debris.
3. Remove the baffles (if installed) from the flue passages. Refer to Section 3, Paragraph F for Baffle Installation.

4. Clean the 3rd Pass – Insert a 2 in. dia. x 42 in. long wire or fiber bristle brush into each of the two 3rd passes. Using long strokes push the brush all the way through the boiler until the brush has exited the smoke box opening. Pull the brush all the way forward until it has exited the front of the boiler. Continue this operation for the entire height of the flue way until clean. Repeat the operation for the other 3rd pass flue way.
5. Clean the 2nd Pass - Insert a 2 in. dia. x 42 in. long wire or fiber bristle brush into each of the two 2nd passes. Using long strokes push the brush all the way through the boiler until the brush hits the back wall of the reversing chamber. Pull the brush all the way forward until it has exited the front of the boiler. Continue this operation for the entire height of the flue way until clean. Repeat the operation for the other 2nd pass flue way.
6. Vacuum the loose debris in the bottom of the combustion chamber and smoke box.

B. CLEAN THE COMBUSTION CHAMBER

– Use a wire or fiber bristle brush to clean the surfaces of the combustion chamber. Vacuum all of the loose debris in the bottom of the combustion chamber.

- #### **C. AFTER CLEANING,**
- vacuum all remaining debris as necessary. Inspect burner swing door insulation, and rope gasket for signs of damage. If damaged, replace as needed.

D. REASSEMBLE BOILER.

CAUTION

Do not start the burner unless the burner swing door and canopy cover plates are secured in place.

1. Insert the baffles (if originally installed) into the correct flue way. Refer to Section 3, Paragraph F for Baffle Installation.

12 Boiler Cleaning *(continued)*

- Attach the smoke box clean-out covers onto the rear of the boiler. Verify that the rope gasket is in good working order before assembly. Replace rope gasket if necessary. Use the 3/8 in. hardware originally removed. Do not over tighten. They should be snug but not bottomed out.

NOTICE: When securing burner swing door make sure door is drawn-in equally on both sides.

Tighten swing door hardware to provide adequate seal to rope gasket around perimeter of door.

Use an alternating tightening method from right side to left side cap screw to pull door tight equally.

NOTICE: Do not overtighten. The rope gasket will provide sufficient seal when the door is snugged into place.

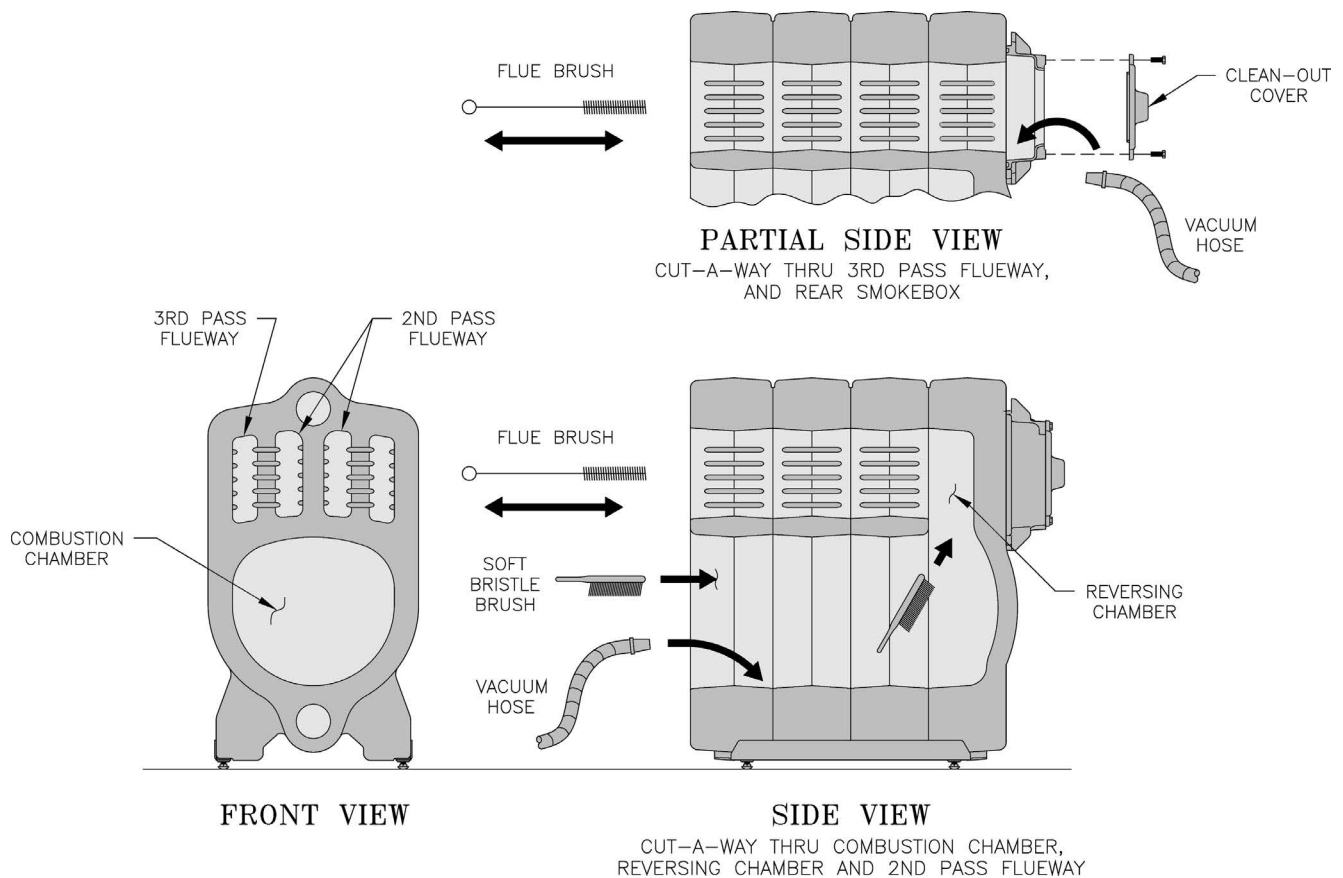

Figure 12-1: Cleaning of Boiler Flueways

⚠ WARNING

The boiler must be connected to an approved chimney in good condition. Serious property damage could result if the boiler is connected to a dirty or inadequate chimney. The interior of the chimney flue must be inspected and cleaned before the start of the heating season and should be inspected periodically throughout the heating season for any obstructions. A clean and unobstructed chimney flue is necessary to allow noxious fumes that could cause injury or loss of life to vent safely and will contribute toward maintaining the boiler's efficiency.

13 Troubleshooting

A. COMBUSTION

1. **NOZZLES** — Although the nozzle is a relatively inexpensive device, its function is critical to the successful operation of the oil burner. The selection of the nozzle supplied with the FWC boiler is the result of extensive testing to obtain the best flame shape and efficient combustion. Other brands of the same spray angle and spray pattern may be used but may not perform at the expected level of CO₂ and smoke. Nozzles are delicate and should be protected from dirt and abuse. Nozzles are mass-produced and can vary from sample to sample. For all of those reasons a spare nozzle is a desirable item for a serviceman to have.
2. **FUEL LEAKS** — Any fuel leak between the pump and the nozzle will be detrimental to good combustion results. Look for wet surfaces in the air tube, under the ignitor, and around the air inlet. Any such leaks should be repaired as they may cause erratic burning of the fuel and in the extreme case may become a fire hazard.
3. **SUCTION LINE LEAKS** — Any such leaks should be repaired, as they may cause erratic burning of the fuel and in extreme cases may become a fire hazard. Whatever it takes, **The Oil Must Be Free of Air**. This can be a tough problem, but it must be resolved. Try bleeding the pump through a clear tube. There must be no froth visible. There are various test kits available to enable you to look at the oil through clear tubing adapted to the supply line at the pump fitting. Air eliminators are on the market that have potential. Also, electronic sight glasses are being used with good success. At times, new tubing must be run to the tank or new fittings put on. Just make sure you get the air out before you leave.
Any air leaks in the fuel line will cause an unstable flame and may cause delayed ignition noises. Use only flare fittings in the fuel lines.
4. **GASKET LEAKS** — If 11.5 to 12.5% CO₂ with a #1 smoke cannot be obtained in the breeching, look for air leaks around the burner mounting gasket, observation door, and canopy gasket. Such air leaks will cause a lower CO₂ reading in the breeching. The smaller the firing rate the greater effect an air leak can have on CO₂ readings.
5. **DIRT** — A fuel filter is a good investment. Accidental accumulation of dirt in the fuel system can clog the nozzle or nozzle strainer and produce a poor spray pattern from the nozzle. The smaller the firing rate, the smaller the slots become in the nozzle and the more prone to plugging it becomes with the same amount of dirt.
6. **WATER** — Water in the fuel in large amounts will stall the fuel pump. Water in the fuel in smaller amounts will cause excessive wear on the pump, but more importantly water doesn't burn. It chills the flame and causes smoke and unburned fuel to pass out of the combustion chamber and clog the flueways of the boiler.
7. **COLD OIL** — If the oil temperature approaching the fuel pump is 40°F or lower, poor combustion or delayed ignition may result. Cold oil is harder to atomize at the nozzle. Thus, the spray droplets get larger and the flame shape gets longer. An outside fuel tank that is above grade or has fuel lines in a shallow bury is a good candidate for cold oil. The best solution is to locate the tank near the boiler in the basement utility room or bury the tank and lines deep enough to keep the oil above 40°F. Check environmental issues with local authorities having jurisdiction.
8. **FLAME SHAPE** — Looking into the combustion chamber through the observation port, the flame should appear straight with no sparklers rolling up toward the crown of the chamber. If the flame drags to the right or left, sends sparklers upward or makes wet spots on the target wall, the nozzle should be replaced. If the condition persists look for fuel leaks, air leaks, water or dirt in the fuel as described above.
9. **HIGH ALTITUDE INSTALLATIONS** — Air openings must be increased at higher altitudes. Use instruments and set for 11.5 to 12.5% CO₂.
10. **START-UP NOISE** — Late ignition is the cause of start-up noises. If it occurs recheck for electrode settings, flame shape, air or water in the fuel lines.

13 Troubleshooting *(continued)*

11. SHUT DOWN NOISE — If the flame runs out of air before it runs out of fuel, an after burn with noise may occur. That may be the result of a faulty cut-off valve in the fuel pump, or it may be air trapped in the nozzle line. It may take several firing cycles for that air to be fully vented through the nozzle. Water in the fuel or poor flame shape can also cause shut down noises.

NOTICE: CHECK TEST PROCEDURE. A very good test for isolating fuel side problems is to disconnect the fuel system and with a 24 in. length of tubing, fire out of an auxiliary five gallon pail of clean, fresh, warm #2 oil from another source. If the burner runs successfully when drawing out of the auxiliary pail then the problem is isolated to the fuel or fuel lines being used on the jobsite.

B. OIL PRIMARY CONTROL (Oil Primary)

1. Burner (Oil Primary) will not come on.
 - a. No power to Oil Primary.
 - b. Oil Primary is in lockout or restricted mode. Press reset button for one (1) second to exit lockout. If control has recycled three times within the same call for heat, it will enter into restricted mode. To reset from restricted mode, refer to Section 10, Paragraph I, Step 2 for details.
 - c. CAD cell seeing light.
 - d. CAD assembly defective.
 - e. Control motor relay is stuck closed (see note below).
2. Burner (control) will light, then shut down after a short time, then restart after one (1) minute.
 - a. CAD cell is defective.
 - b. Air leaking into oil line causing flame out.
 - c. Defective nozzle causing flame to be erratic.
 - d. Excessive airflow or draft causing flame to leave burner head.
 - e. Excessive back pressure causing flame to be erratic.
3. Control locks out after Trial For Ignition (TFI).
 - a. No oil to burner.
 - b. Shorted electrodes.
 - c. Nozzle clogged.
 - d. Airflow too high.
 - e. Ignitor module defective.
 - f. CAD cell defective.
 - g. Oil valve stuck open or closed.

Note: The Safety Monitoring Circuit (SMC) is designed to provide lockout in the event of a stuck or welded motor relay.

14 Service Parts

All service parts may be obtained through your local Velocity Boiler Works wholesale distributor. Should you require assistance in locating a Velocity Boiler Works distributor in your area, or you have questions regarding the availability of products or service parts, please contact us at (215) 535-8900 or Fax (215) 535-9736 or at www.velocityboilerworks.com.

14 Service Parts *(continued)*

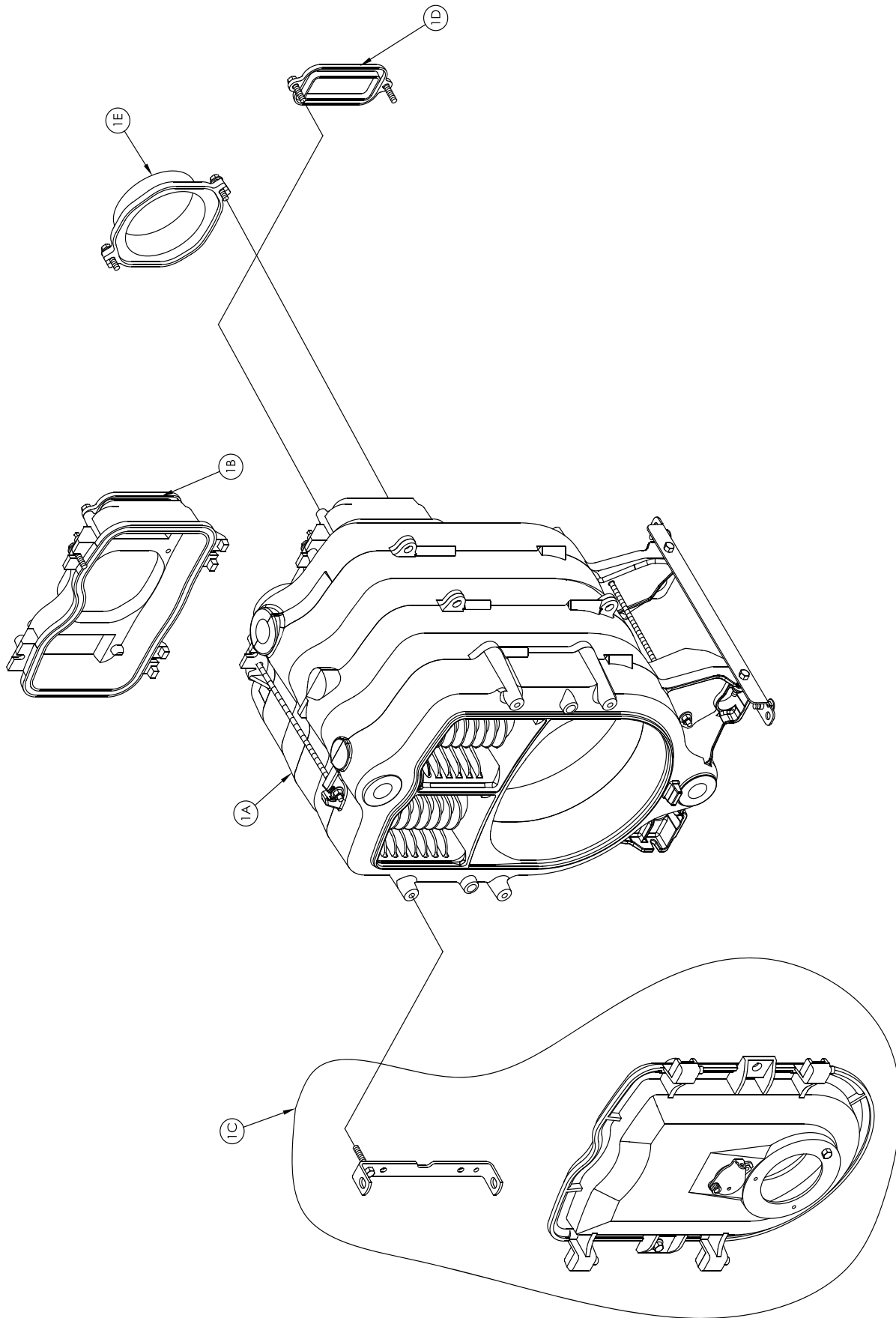

Bare Boiler Assembly

14 Service Parts *(continued)*

Bare Boiler Assembly

Item No.	Description	Part Number	FWC-060	FWC-080	FWC-100	FWC-130	FWC-160
1A	Heater Block Assembly Includes: Block Assembly and Smoke Box	109554-02	1	1			
		109554-03			1		
		109554-04				1	
		109554-05					1
		109554-06					
1B	Smoke Box Includes: Sealant, and Hardware	109555-01	1	1	1	1	1
1C	Burner Swing Door Assembly	109556-01	1	1	1	1	
		109557-01					1
1D	Cleanout Cover Assembly	109563-01	2	2	2	2	2
1E	Flue Collar Includes: Hardware	109567-01	1	1			
		109568-01			1	1	
		109568-01					1
Not Shown	Gasket Assembly Includes: Door Rope Gasket, Door Insulation, two (2) Cleanout Cover Rope Gaskets, and RTV Sealant	109738-01	1	1	1	1	
		109738-02					1

14 Service Parts *(continued)*

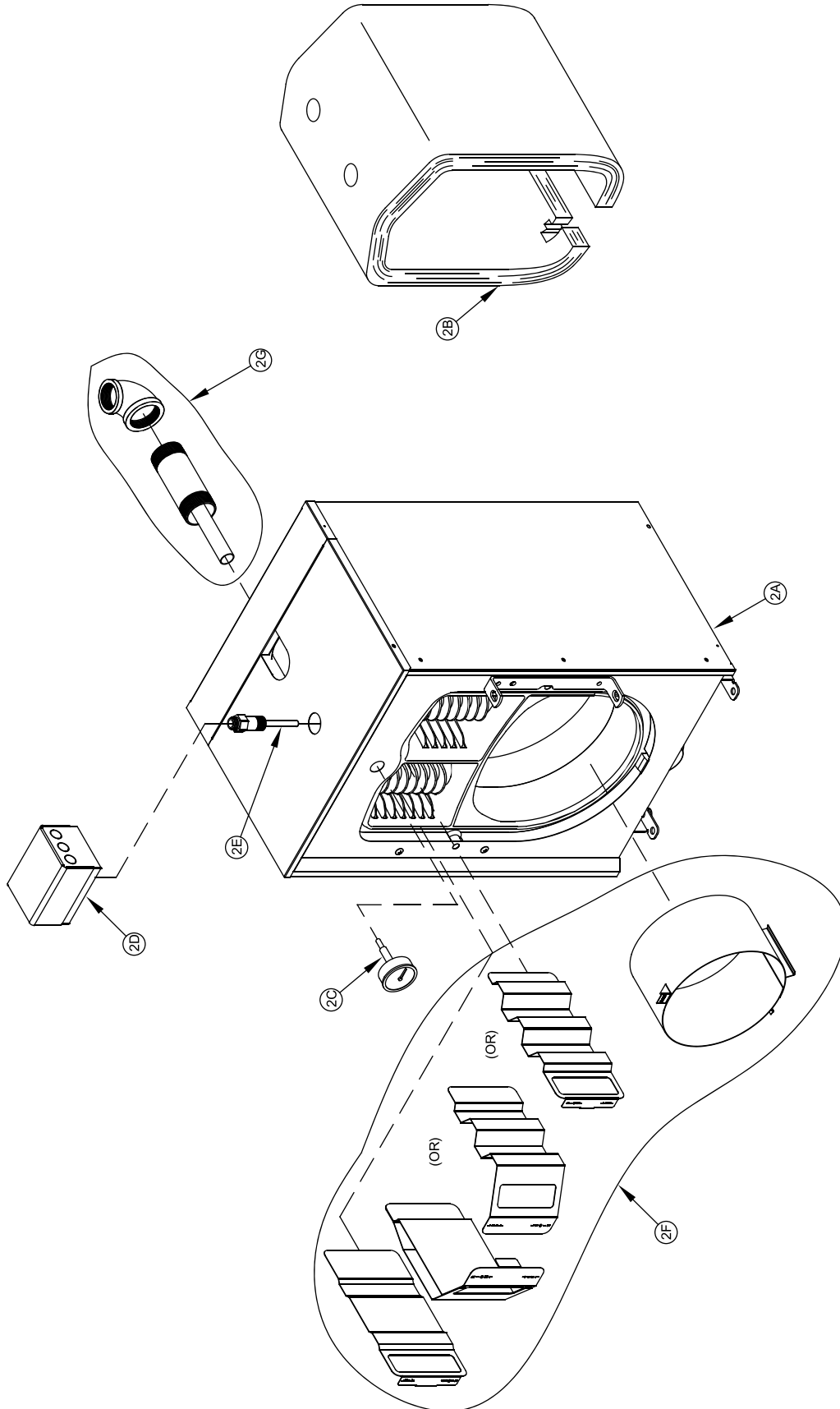

Jacket Assembly

14 Service Parts *(continued)*

Jacket and Trim

Item No	Description	Part Number	FWC-060	FWC-080	FWC-100	FWC-130	FWC-160	
2A	Complete Jacket Carton Includes: Labels and Hardware	112947-02	1	1				
		112947-03			1			
		112947-04				1		
		112947-05					1	
2B	Wrap Around Insulation	109553-02	1	1				
		109553-03			1			
		109553-04				1		
		109553-05					1	
2C	Temperature Pressure Gauge	105894-01	1	1	1	1	1	
2D	Control	HydroStat 3250	105894-01	1	1	1	1	
2E	Electro-Well, 1/2 in. NPT x 3-1/4 in.	109566-01	1	1	1	1	1	
2F	Baffle Kit	109991-01	1					
		111779-01		1				
		109558-01			1	1	1	
2G	Injector Kit	102827-01	1	1	1	1	1	
Not Shown	Relief Valve, Conbraco, 3/4 in. FIP x 3/4 in. FIP	#10-408-05 30PSI	Obtain Locally	1	1	1	1	1
		#10-303-07 40 PSI						
		#10-303-10 50 PSI						
	5 in. Draft Regulator			1	1			
	6 in. Draft Regulator					1	1	
	7 in. Draft Regulator							1
	Drain Valve, 3/4 in. NPT			1	1	1	1	1
	Circulator Flange 1-1/2 NPT			2	2	2	2	2
	Circulator Gasket	Taco *194-1548		2	2	2	2	2
Circulator	Taco 007e	1	1	1	1	1		

14 Service Parts *(continued)*

Oil Burners

Item No.	Description		Part Number	FWC-060	FWC-080	FWC-100	FWC-130	FWC-160	
Not Shown	Beckett Burner Assembly (Fully configured burner with nozzle and burner cord assembly)	Natural Draft	112312-01	1					
			112313-01		1				
			112314-01			1			
			112315-01				1		
			112978-01					1	
	Carlin Burner Assembly (Full configured burner with nozzle and burner cord assembly)	Natural Draft	106755-01	1					
			106776-01		1				
			106777-01			1			
			106778-01				1		
			112989-01					1	
	Primary	Beckett	GeniSys 7565	Obtain Locally	1	1	1	1	1
		Carlin	Pro-X 70200		1	1	1	1	1
	Burner Harness	Beckett	Natural Draft	113162-01	1	1	1	1	1
		Carlin	Natural Draft	113163-01	1	1	1	1	1

15 Burner Specifications

Table 15-1: Beckett Burner Specifications - Chimney Vent

Boiler Model	Burner Input (GPH)	Burner Model	Head Type (setting)	Air Shutter (setting)	Air Band (setting)	Nozzle	Pump Pressure (PSI)
FWC-060 ⁽¹⁾	0.60	AFG	L2	8	0	0.50 x 45W Delavan	180
FWC-080	0.80	AFG	L2	5	0	0.60 x 45W Delavan	180
FWC-100	1.00	AFG	L1	9	0	0.75 x 60B Delavan	180
FWC-130	1.30	AFG	V1 (0)	7	1	1.00 X 60B Delavan	180
FWC-160	1.60	AFG	V1 (3)	10	3	1.25 x 60B Delavan	180

Notes

⁽¹⁾ Utilizes a low fire baffle.

Single stage fuel pump is standard, two stage fuel pump is optional. Burner manufacturer has preset single stage fuel pump to settings shown in table above. Two stage fuel pump is factory set at 40 PSI and must be readjusted to settings shown above during burner start-up.

Table 15-2: Carlin Burner Specifications- Chimney Vent

Boiler Model	Burner Input (GPH)	Burner Model	Air Tube Type	Head Setting	Air Setting	Nozzle	Pump Pressure (PSI)
FWC-060 ⁽¹⁾	0.60	EZ-LF	12D	1.00	20	0.50 x 60AS Danfoss	150
FWC-080	0.80	EZ-LF	12D	0.75	70	0.65 x 60A Delavan	150
FWC-100	1.00	EZ-66	Conical Wrap	2.00	40	0.85 x 45AS Danfoss	150
FWC-130	1.30	EZ-66	Conical Wrap	3.50	50	1.10 x 45B Delavan	150
FWC-160	1.60	EZ-66	Conical Wrap	5.50	60	1.35 x 45B Delavan	150

**Velocity Boiler Works, LLC
P.O. Box 14818
3633 I Street
Philadelphia, PA 19134**