

# Installation, Operating and Service Instructions for

# Series 49

- Steam Boiler
- Cast Iron
- Chimney Vent
- Gas Fired

**Models:**

- 49-075S
- 49-200S
- 49-450S
- 49-100S
- 49-250S
- 49-500S
- 49-125S
- 49-299S
- 49-550S
- 49-150S
- 49-350S
- 49-175S
- 49-399S

**NOTICE:** Knock-Down Boilers: These instructions address installation and controls. Assembly is addressed in separate instructions shipped with knock-down boilers.

<u>Manual Contents</u>	<u>Page</u>
1. Qualified Installer, Service Agency or Gas Supplier Read Before Proceeding . . . . .	3
2. User/Homeowner Read Before Proceeding . . . . .	4
3. Specifications . . . . .	5
4. Locating Boiler . . . . .	10
5. Preparing Boiler . . . . .	14
6. Venting . . . . .	15
7. Steam Piping . . . . .	18
8. Gas Piping . . . . .	22
9. Electrical . . . . .	24
10. System Start-Up and Checkout . . . . .	31
11. Operation . . . . .	39
12. Before Leaving Jobsite . . . . .	40
13. Service and Maintenance . . . . .	41
14. How it Works . . . . .	45
15. Troubleshooting . . . . .	49
16. Service Parts . . . . .	56
Appendix A Steam Boiler Skimming . . . . .	71
Appendix B Indirect Water Heater . . . . .	72
Appendix C McDonnell & Miller 150S-MD Auto Reset LWCO/Pump Control . . . . .	74

**⚠ WARNING**

**Attention Installer -** Affix these instructions adjacent to boiler. Provide model number and serial number when seeking information and support.

**Attention Building Owner -** Retain these instructions for future reference. Contact a qualified installer, service agency or gas supplier for all issues and support.



**⚠ WARNING**

This boiler must only be installed, serviced, and repaired by a qualified installer, service agency or gas supplier. Improper installation, adjustment, alteration, service or maintenance can cause severe personal injury, death, or substantial property damage. For assistance or additional information, consult a qualified installer, service agency or gas supplier. Read these instruction carefully before installing.



## Important Definitions of Warnings

Massachusetts Board of Plumbers and Gas Fitters has listed Series 49 Boilers. See Massachusetts Board of Plumbers and Gas Fitters website for latest Approval Code or ask your local Sales Representative.

Commonwealth of Massachusetts requires this product to be installed by a licensed Plumber or Gas fitter.

The following terms are used throughout this manual to bring attention to the presence of hazards of various risk levels, or to important information concerning product life.

### DANGER

Indicates a hazardous situation that, if not avoided, will result in death or serious injury.

### CAUTION

Indicates a hazardous situation that, if not avoided, could result in minor or moderate injury.

### WARNING

Indicates a hazardous situation that, if not avoided, could result in death or serious injury.

**NOTICE:** Indicates special instructions on installation, operation, or service which are important but not related to personal injury hazards.

### DANGER

**Explosion Hazard.** DO NOT store or use gasoline or other flammable vapors or liquids in the vicinity of this or any other appliance.

If you smell gas vapors, DO NOT try to operate any appliance - DO NOT touch any electrical switch or use any phone in building. Immediately, call gas supplier from a remotely located phone. Follow gas supplier's instructions or if the supplier is unavailable, contact fire department.

### WARNING

**This boiler must only be serviced and repaired by a qualified installer, service agency or gas supplier.**

- If any controls are replaced, they must be replaced with identical models.
- Read, understand and follow all instructions and warnings contained in all sections of this manual.
- If any electrical wires are disconnected during service, clearly label wires and assure that wires are reconnected properly.
- Never jump out or bypass any or operating control or component of this boiler.
- Assure that all and operating controls and components are operating properly before placing boiler back in service.
- Inspect boiler annually.

# 1 Qualified Installer, Service Agency or Gas Supplier Read Before Proceeding

## WARNING

### **Asphyxiation Hazard, Burn Hazard, Electrical Shock Hazard.**

- Carefully read all instructions in literature packet and posted on boiler before attempting installation, startup, or service of this boiler. Perform steps in order given. Failure to follow all instructions in proper order could result in severe personal injury, death or substantial property damage.
- Use proper personal protective equipment when installing, servicing, or working near this boiler. Materials of construction, flue products, and fuel contain alumina, silica, heavy metals, carbon monoxide, nitrogen oxides, and/or other toxic or harmful substances that can be hazardous to health and life and that are known to the State of California to cause cancer, birth defects, and other reproductive harm.
- Do not disconnect pipe fittings on boiler or in heating system without first verifying system is cool and free of pressure and that your clothing will protect you from a release of hot water or steam. Do not rely solely on boiler temperature and pressure gauge when making this judgement.
- Install all guards, cover plates, and enclosures before leaving boiler in operation.
- Disconnect electrical supply before installing or performing maintenance.
- **Do not install above 2,000 ft.**
- **Not for use with LP gas.**

## **NOTICE:**

1. Size boiler properly. A grossly oversized boiler will cycle excessively leading to premature failure of boiler and its components. Warranty does not cover damage from excessive cycling.
2. Systems employing baseboard and/or radiators, use an industry accepted sizing method such as the I=B=R "Residential Hydronic Heating Installation and Design" guide published by the Air Conditioning, Heating and Refrigeration Institute (AHRI).
3. Inspect shipment carefully for signs of damage. See Figure 5-1 for parts shipped loose with packaged boilers. Any claim for damage or shortage in shipment must be filed immediately against carrier by consignee. No claims for variances or shortages will be allowed by boiler manufacturer, unless presented within 60 days after receipt of equipment.

## 2 User/Homeowner Read Before Proceeding

### WARNING

#### **Asphyxiation Hazard. Fire Hazard.**

- A qualified installer, service agency or gas supplier should annually inspect boiler.
- If you are not qualified to install or service boilers, do not install or service this one.
- Carbon monoxide is an odorless, deadly gas that may be introduced into your home by any malfunctioning fuel burning product or vent system failure. **Consider installing CO alarms near bedrooms in all levels of building to warn you and your family of potential CO exposure.**
- Do not block air flow into or around boiler or opening for fresh air into boiler room. Insufficient air may cause the boiler to produce carbon monoxide or start a fire.

**NOTICE:** Protect your home in freezing weather. A power outage, operating control, or component failure will prevent your boiler from lighting. In winter your pipes may freeze and cause extensive property damage. Do not leave heating system unattended during cold weather unless alarms or other safeguards are in place to prevent such property damage.

### CAUTION

#### **Burn Hazard.**

Keep children and pets away from hot surfaces of the boiler including boiler piping, vent piping, and vent terminals.

**NOTICE:** Boiler may leak water or steam at the end of its useful life. Be sure to protect walls, carpets, and valuables from water or steam that could leak from boiler.

### 3 Specifications

## Series 49 Gas



Table 3-1: Ratings

Model Number	Input <sup>1</sup> (MBH)	Output (MBH)	Net AHRI Rating <sup>2</sup>		AFUE (%)	Thermal Efficiency (%)	Combustion Efficiency (%)
			Steam (square foot)	Steam (MBH)			
49-075S	75	62	196	47	82.0		
49-100S	100	82	258	62	82.0		
49-125S	125	103	321	77	82.0		
49-150S	150	124	388	93	82.0		
49-175S	175	144	450	108	82.0		
49-200S	200	165	517	124	82.0		
49-250S	250	206	646	155	82.0		
49-299S	299	246	771	185	82.0		
49-350S	350	284	890	213		81.0	82.5
49-399S	399	323	1012	242		81.0	82.5
49-450S	450	365	1143	274		81.0	82.5
49-500S	500	405	1269	304		81.0	82.5
49-550S	550	446	1397	335		81.0	82.5

<sup>1</sup> Input ratings can be used for elevations up to 2,000 ft.

<sup>2</sup> Net AHRI Ratings shown are based on a piping and pickup allowance of 1.333. The manufacturer should be consulted before selecting a boiler for installations having unusual piping and pickup requirements, such as intermittent operation, extensive piping systems, etc.

### 3 Specifications *(continued)*

**Table 3-2: Dimensions and Connections**

Boiler Model Number	No. of Sections	Height (in)	Width (in)	Depth <sup>1</sup> (in)	Supply <sup>2</sup> (NPT)	Return (NPT)	Vent <sup>3</sup> (in)	Gas <sup>4</sup> (NPT)	Relief Valve (NPT)	Min. Relief Valve Capacity (lb./hr.)
49-075S	3	41	16 5/16	30	(1) 2	2	5	1/2	3/4	62
49-100S	3	41	16 5/16	30	(1) 2	2	5	1/2	3/4	82
49-125S	4	41	21 3/8	30	(1) 2	2	6	1/2	3/4	103
49-150S	4	41	21 3/8	30	(1) 2	2	6	1/2	3/4	124
49-175S	5	41	26 7/16	30	(2) 2	2	7	3/4	3/4	144
49-200S	5	41	26 7/16	30	(2) 2	2	7	3/4	3/4	165
49-250S	6	41	31 1/2	30	(2) 2	2	8	3/4	3/4	206
49-299S	7	41	36 9/16	30	(2) 2	2	8	3/4	3/4	246
49-350S	8	41	41 5/8	30	(3) 2	2	6 & 7	1/2 & 3/4	3/4	284
49-399S	9	41	46 11/16	30	(3) 2	2	6 & 8	1/2 & 3/4	1	323
49-450S	10	41	51 3/4	30	(4) 2	2	7 & 8	3/4 & 3/4	1	365
49-500S	11	41	56 13/16	30	(4) 2	2	8 & 8	3/4 & 3/4	1	405
49-550S	12	41	61 7/8	30	(4) 2	2	8 & 8	3/4 & 3/4	1	446

<sup>1</sup> Depth less draft hood. Depth with draft hood installed is 40 in.

<sup>2</sup> (3) 2 indicates three 2 inch risers.

<sup>3</sup> 6 & 7 indicates both 6 and 7 inch vent connections.

<sup>4</sup> 1/2 & 3/4 indicates both 1/2 and 3/4 inch gas connections.

Drain connection = 3/4 inch NPT

Maximum allowable working pressure (MAWP) = 15 psi

**Table 3-3: Shipping Weights and Dimensions**

Boiler Model Number	Shipping Weight	Shipping Crate Depth	Shipping Crate Width	Shipping Crate Height
49-100S	480	37	32	47
49-125S	595	37	32	47
49-150S	595	37	32	47
49-175S	725	37	47	47
49-200S	725	37	47	47
49-250S	840	37	47	47

### 3 Specifications *(continued)*

Boiler	A	B	C	D	E
49-075S	16 5/16	NA	5	6	8 1/2
49-100S	16 5/16	NA	5	6	8 1/2
49-125S	21 3/8	NA	6	6 1/2	11
49-150S	21 3/8	NA	6	6 1/2	11
49-175S	26 7/16	10 3/16	7	7	13 1/2
49-200S	26 7/16	10 3/16	7	7	13 1/2
49-250S	31 1/2	15 1/4	8	8	16
49-299S	36 9/16	20 3/8	8	8	18 1/2

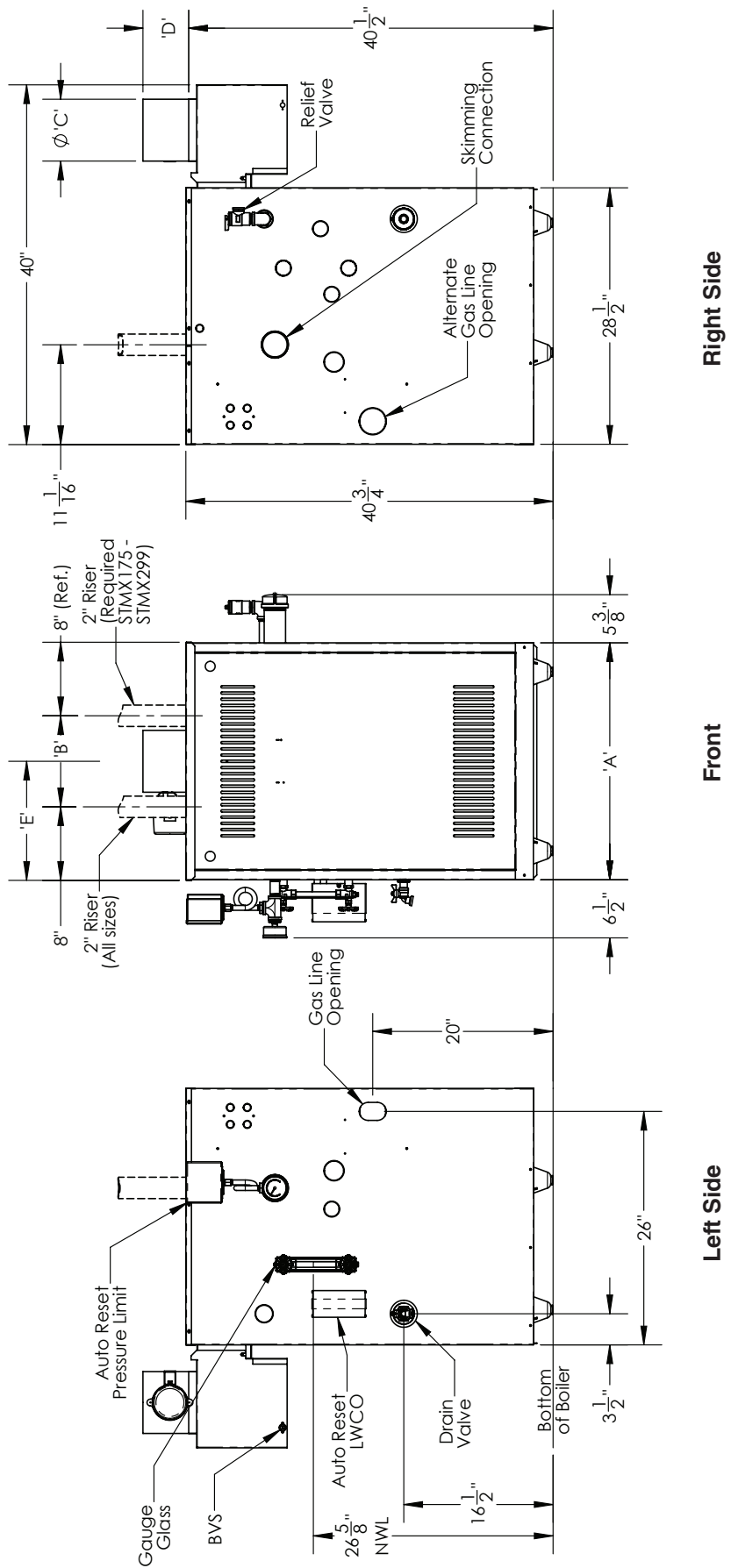


Figure 3-4: Dimensional Drawing 49-075S through 49-299S

### 3 Specifications *(continued)*

Boiler	A	B	C	D	E	F	G	H
49-350S	41 5/8	15 1/4	10 3/16	NA	11	17 1/2	6	7
49-399S	46 11/16	15 1/4	15 1/4	NA	11	20	6	8
49-450S	51 3/4	10 3/16	10 3/16	15 1/4	13 1/2	22 1/2	7	8
49-500S	56 13/16	15 1/4	10 3/16	15 1/4	16	25	8	8
49-550S	61 7/8	15 1/4	15 1/4	15 1/4	16	27 1/2	8	8

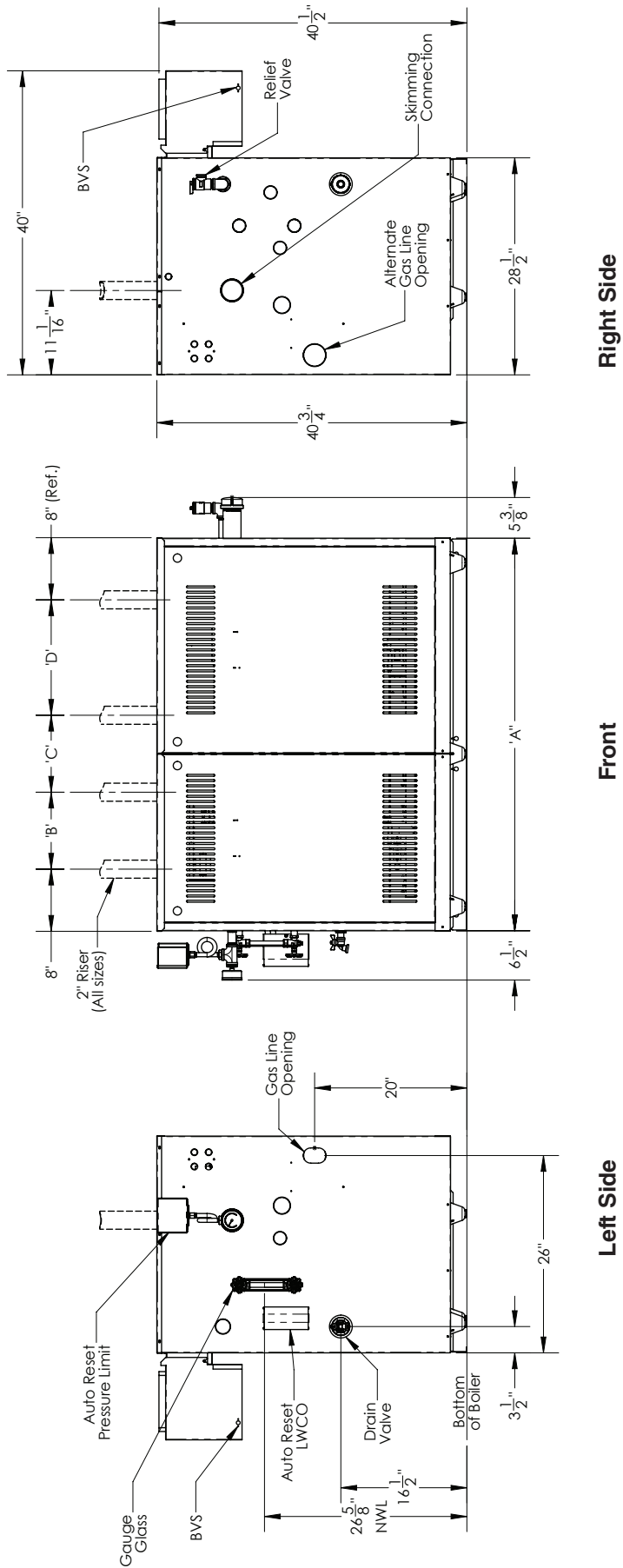
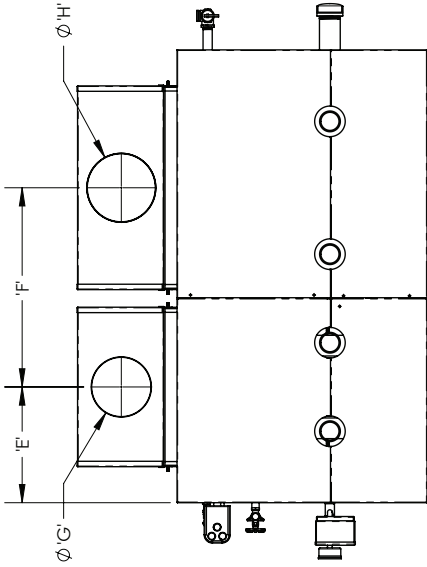
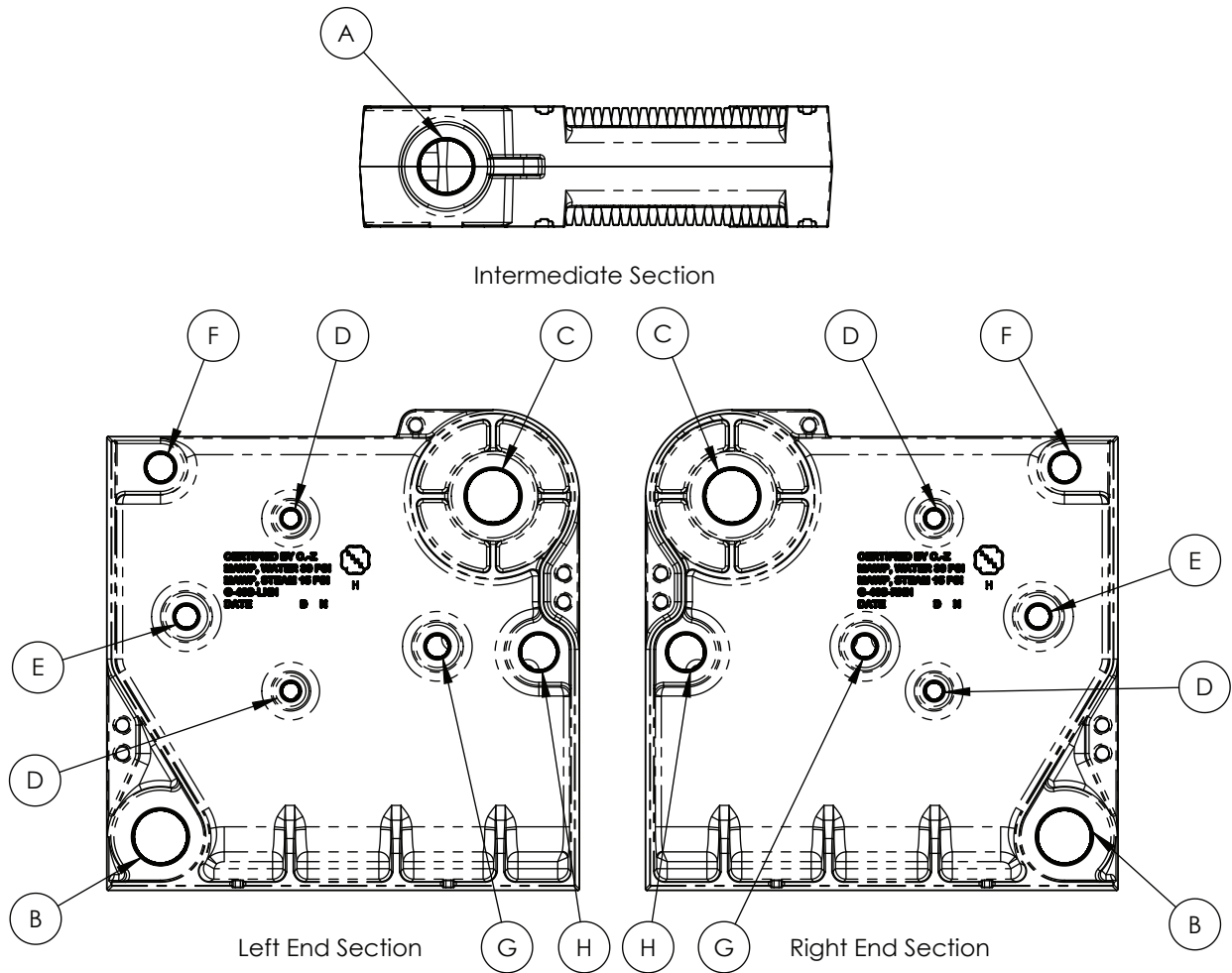


Figure 3-5: Dimensional Drawing 49-350S through 49-550S



### 3 Specifications *(continued)*



**Figure 3-6: Section Tappings**

**Table 3-7: Trim and Control Installation in Section Tappings**

Tapping	Size (NPT)	Function
A	2	Supply
B	2	Return and/or Bushed Down for Drain
C	2	Skimming Connection or Bushed Down for Auto Reset Pressure Limit, Manual Reset Pressure Limit and Pressure Gauge
D	1/2	Gauge Glass
E	3/4	Auto Reset LWCO
F	1	Relief Valve
G	3/4	Manual Reset LWCO
H	1-1/4	IWH Connection

## 4 Locating Boiler

### Code Requirements

1. Installations must conform to requirements of authority having jurisdiction or, in the absence of such requirements, to *National Fuel Gas Code*, ANSI Z223.1/NFPA 54.
2. All wiring must comply with *National Electrical Code* ANSI/NFPA 70.
3. Where required by authority having jurisdiction, installation must conform to *Standard for Controls and Safety Devices for Automatically Fired Boilers*, ANSI/ASME CSD-1.

### Location Considerations

1. Provide combustion and ventilation air in accordance with section "Air for Combustion and Ventilation," of *National Fuel Gas Code*, ANSI Z223.1/NFPA 54, or applicable provisions of local building codes.
2. If replacing an existing boiler, check for and correct common system problems including:
  - A. System leaks resulting in premature heat exchanger failure from oxygen corrosion or hardness deposits
  - B. Inadequate freeze protection resulting in system freezing and leaking
  - C. Dirt or debris left in existing piping if it has not been properly flushed or cleaned
3. Appliance is listed for installation on combustible flooring and must not be installed on carpeting.
4. Install on level floor. For basement installation provide concrete base if floor is not level or if water may be encountered on floor around boiler.
5. Protect gas ignition system components from water (dripping, spraying, etc.) during appliance operation and service.
6. Locate boiler to avoid water damage in case there is a leak. If boiler must be located in an area sensitive to water damage, install drain pan underneath boiler and pipe to a suitable drain location. Manufacturer will not be held responsible for water damage resulting from this appliance or any of its components.
7. Check for and remove any combustible materials, gasoline, or other flammable liquids from area around boiler.
8. Check for and remove any potential combustion air contaminants from area around boiler. See Table 4-1.

**NOTICE:** Flue side corrosion caused by contaminants is not covered by warranty.

**Table 4-1: Corrosive Combustion Contaminants and Sources**

Contaminants to avoid:
Spray cans containing chloro/fluorocarbons (CFC's)
Permanent wave solutions
Chlorinated waxes/cleaners
Chlorine-based swimming pool chemicals
Calcium chloride used for thawing
Sodium chloride used for water softening
Refrigerant leaks
Paint or varnish removers
Hydrochloric acid/muriatic acid
Cements and glues
Antistatic fabric softeners used in clothes dryers
Chlorine-type bleaches, detergents, and cleaning solvents found in household laundry rooms.
Adhesives used to fasten building products and other similar products
Excessive dust and dirt
Areas likely to have contaminants:
Dry cleaning/laundry areas and establishments
Swimming pools
Metal fabrication plants
Beauty shops
Refrigeration repair shops
Photo processing plants
Auto body shops
Plastic manufacturing plants
Furniture refinishing areas and establishments
New building construction
Remodeling areas
Garages with workshops

### Clearances

1. Provide clearances between boiler jacket and combustible material in accordance with authority having jurisdiction. Minimum clearances to combustible material shown in Figure 4-2 and 4-3.
2. **Recommend 24 in. service clearance from left side, right side and front.**  
**NOTICE:** If recommended service clearances are not provided, it may be necessary to remove boiler for service.
3. Boiler must not be installed on carpeting.

## 4 Locating Boiler *(continued)*

Boiler	A
49-075S	16 5/16
49-100S	16 5/16
49-125S	21 3/8
49-150S	21 3/8
49-175S	26 7/16
49-200S	26 7/16
49-250S	31 1/2
49-299S	36 9/16

**NOTICE:** 24 in. service clearance recommended from left side, right side, and front.

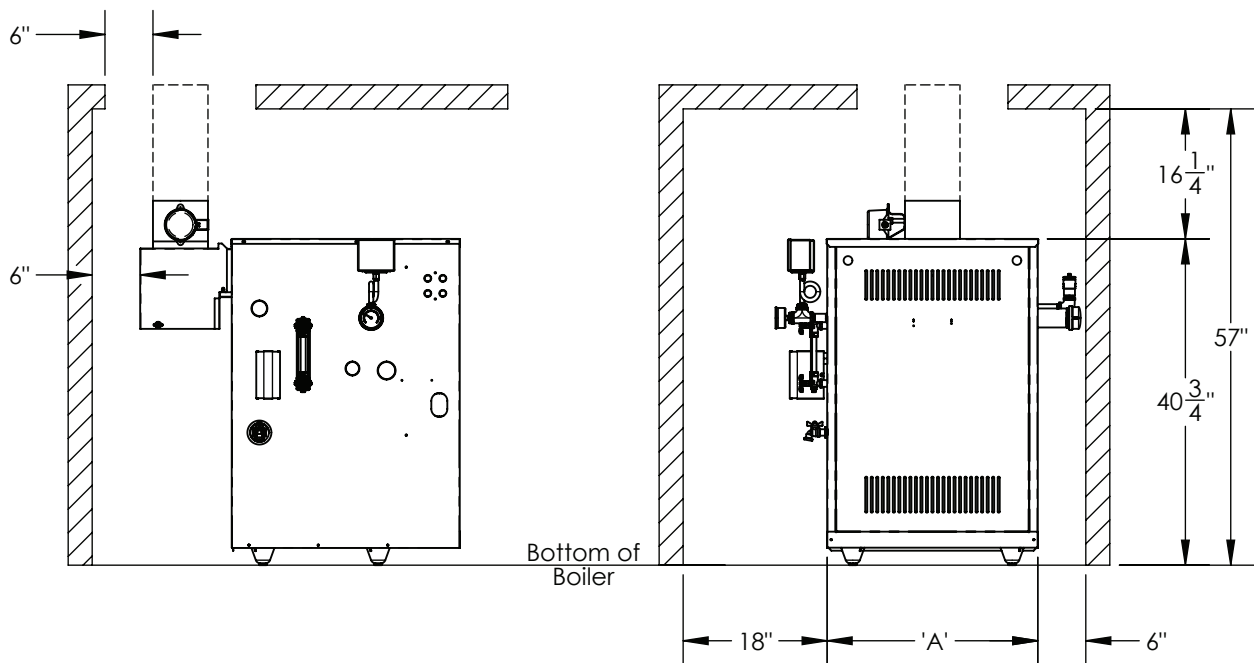


Figure 4-2: Minimum Alcove Clearances 49-075S through 49-299S

## 4 Locating Boiler *(continued)*

Boiler	A
49-350S	41 5/8
49-399S	46 11/16
49-450S	51 3/4
49-500S	56 13/16
49-550S	61 7/8

**NOTICE:** 24 in. service clearance recommended from left side, right side, and front.

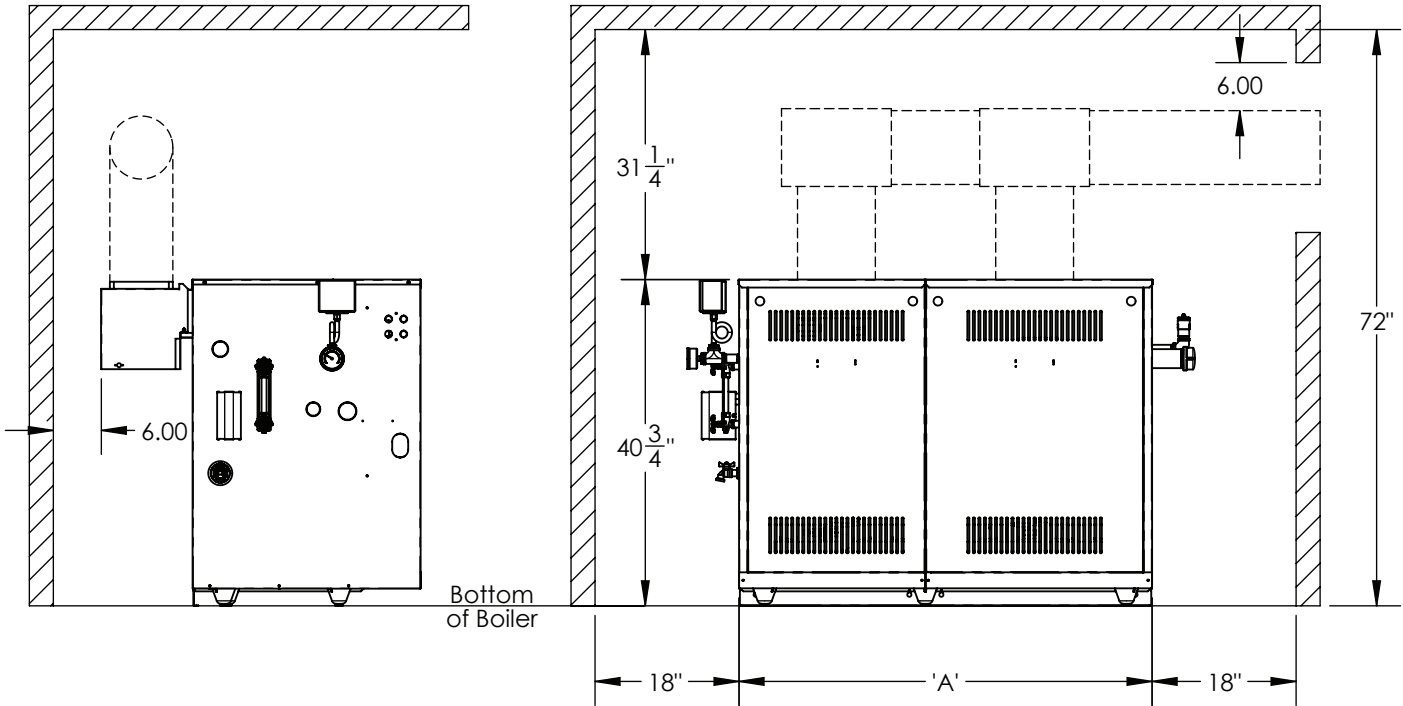


Figure 4-3: Minimum Alcove Clearances 49-350S through 49-550S

## 4 Locating Boiler *(continued)*

### **Before Removing Existing Boiler**

Take pictures and measure and/or mark existing steam and condensate return piping to ensure proper re-piping of new boiler. Support existing piping before disconnecting to prevent change in pitch.

### **After Removing Existing Boiler**

When an existing boiler is removed from a common venting system, the common venting system is likely to be too large for proper venting of appliances remaining connected to it.

At time of removal of an existing boiler, the following steps shall be followed with each appliance remaining connected to the common venting system placed in operation, while the other appliances remaining connected to the common venting system are not in operation:

1. Seal any unused openings in the common venting system.
2. Visually inspect venting system for proper size and horizontal pitch and determine there is no blockage or restriction, leakage, corrosion, and other deficiencies which could cause an unsafe condition.
3. Insofar as is practical, close all building doors and windows and all doors between the space in which the appliances remaining connected to the common venting system are located and other spaces of building. Turn on clothes dryers and any appliance not connected to the common venting system. Turn on any exhaust fans, such as range hoods and bathroom exhausts, so they will operate at maximum speed. Do not operate a summer exhaust fan. Close fireplace dampers.
4. Place in operation appliance being inspected. Follow Operating Instructions. See Figure 10-1. Adjust thermostat so appliance will operate continuously.
5. Test for spillage at draft hood relief opening after 5 minutes of main burner operation. Use flame of a match or candle, or smoke from a cigarette, cigar or pipe.
6. After it has been determined that each appliance remaining connected to the common venting system properly vents when tested as outlined above, return doors, windows, exhaust fans, fireplace dampers and any other gas-burning appliance to their previous condition of use.
7. Any improper operation of the common venting system should be corrected so the installation conforms with the *National Fuel Gas Code*, ANSI Z223.1/NFPA 54. When resizing any portion of the common venting system, the common venting system should be resized to approach minimum size as determined using appropriate tables in Chapter 13 of the *National Fuel Gas Code*, ANSI Z223.1/NFPA 54.

## 5 Preparing Boiler

### Unpack Boiler

Remove boiler and miscellaneous parts carton from outer shipping carton.

#### **⚠ DANGER**

Use precautions and appropriate rigging apparatus when moving heavy objects.

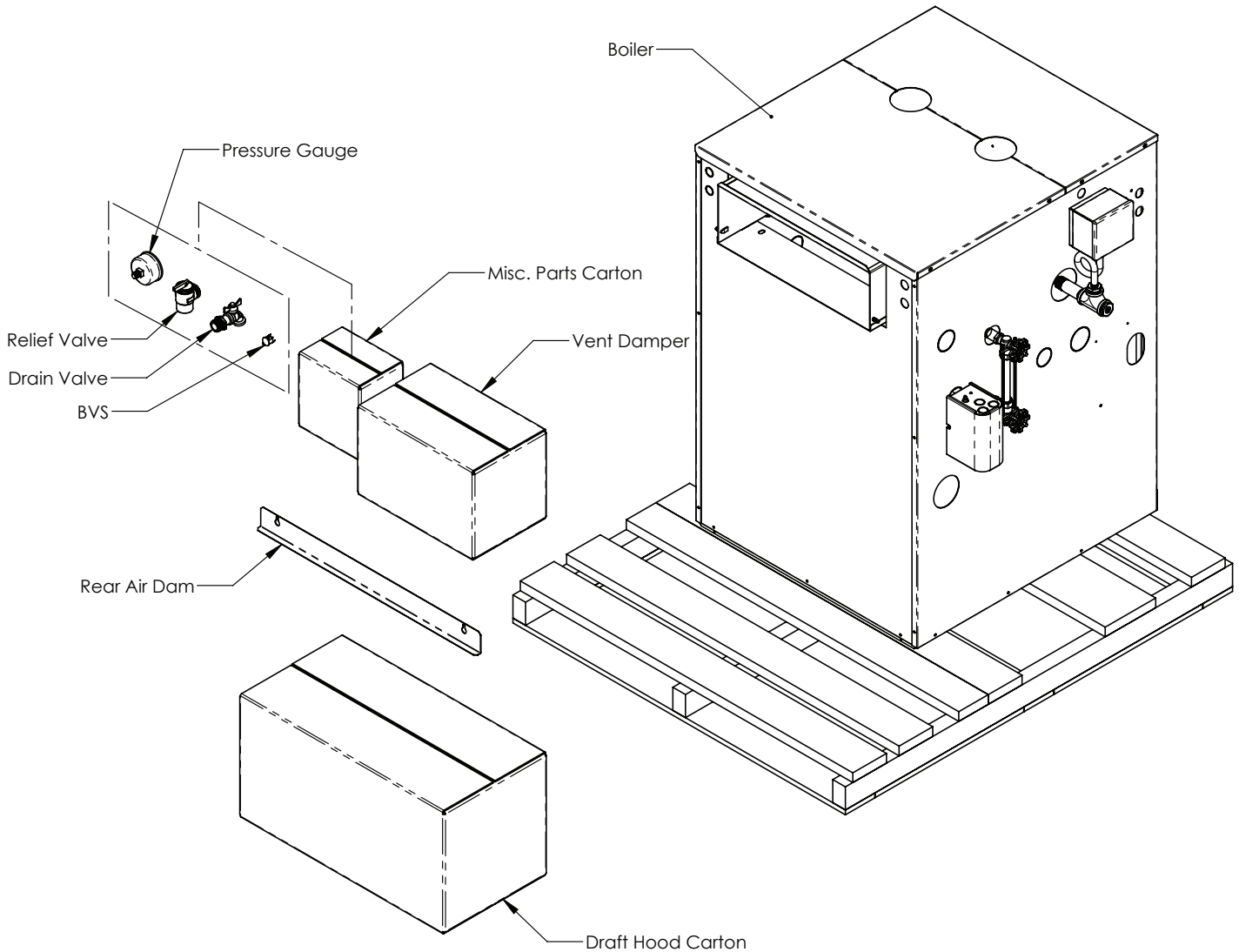


Figure 5-1: Packaged 49-100S through 49-250S

## 6 Venting

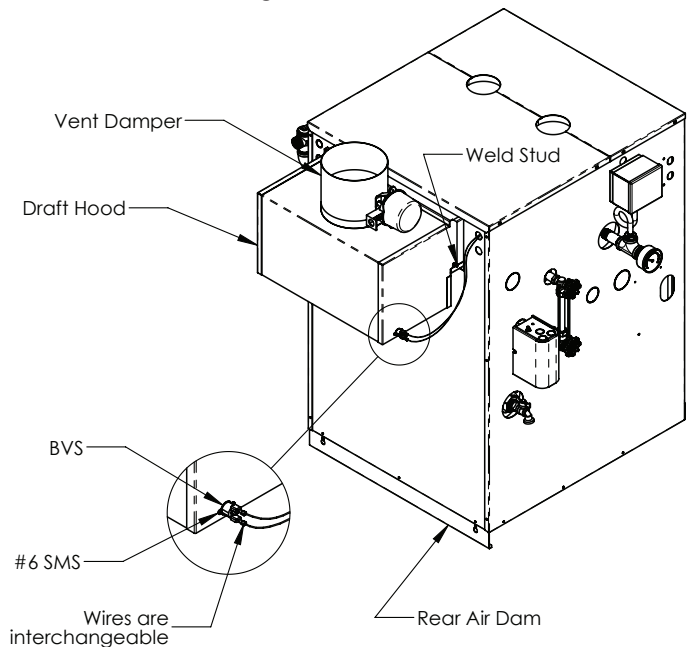
### General

#### ⚠ WARNING

##### Asphyxiation Hazard.

- Failure to vent this boiler in accordance with these instructions could cause products of combustion and/or carbon monoxide to enter living space, resulting in severe personal injury, death or substantial property damage.
  - Vent installation shall be in accordance with local codes, authority having jurisdiction or *National Fuel Gas Code, ANSI Z223.1/NFPA 54* or applicable requirements of the local building codes.
  - Follow instructions in Section 4 Locating Boiler when removing a boiler from an existing vent system.
  - Maintain clearances to vent piping and draft hood per Figures 4-2 and 4-3.
  - Do not use CPVC, PVC, Polypropylene or any other non-metallic vent pipe.
1. Locate boiler as close to chimney as possible. See Figure 4-2 and 4-3 for minimum clearances.
  2. Install vent system in accordance with local codes, authority having jurisdiction or *"National Fuel Gas Code, ANSI Z223.1/NFPA 54. Series 49 boilers are Category I, draft hood equipped appliances. A vent damper is provided with 49-100S through 49-299S boilers. 49-350S through 49-550S boilers do not have vent dampers.*
    - A. Acceptable Chimneys
      - i. Listed Type B or Type L gas vent. Install in accordance with manufacturer's installation instructions, local codes, authority having jurisdiction or *National Fuel Gas Code, ANSI Z223.1/NFPA 54.*
      - ii. Masonry chimney. Build and install in accordance with local codes, authority having jurisdiction or *Standard for Chimney's Fireplaces, Vents and Solid Fuel Burning Appliances, NFPA 211.*
    - B. Acceptable Vent Connections
      - i. Listed Type B or Type L gas vent.
      - ii. Single wall galvanized vent. Use 0.018" (26 gauge or heavier). The size and location of the chimney may not permit the use of a single wall connector in some cases. See *National Fuel Gas Code, ANSI Z223.1/NFPA 54.*
  3. Do not connect vent of this appliance into any portion of a mechanical vent system operating under positive pressure.
  4. Do not connect boiler into a chimney flue servicing an open fireplace or other solid fuel appliance.
  5. Prior to boiler installation, inspect chimney for obstructions or other defects and correct as required. Clean chimney as necessary.
  6. The vertical section of vent pipe coming off boiler should be as tall as possible, while still maintaining the proper clearance from horizontal vent connector to combustibles.
  7. Vent pipe should slope upward from draft hood not less than one inch in four feet. No portion of vent pipe should run downward or have sags. Vent pipe must be securely supported.
  8. Vent pipe should be installed above bottom of chimney to prevent blockage.
  9. Vent pipe must be inserted flush with inside face of chimney liner and the space between vent pipe and chimney sealed tight.
  10. Do not install vent damper in any portion of vent system which is used by appliances other than the boiler being installed.

Do not use single wall pipe for vent connections in attics.



**Figure 6-1: Vent Damper, Rear Air Dam and BVS Installation Diagram (49-075S through 49-299S)**

## 6 Venting *(continued)*

### Single Draft Hood System

#### (49-075S - 49-299S)

1. Install vent damper.

OPEN VENT DAMPER CARTON and remove Installation Instructions. READ INSTALLATION INSTRUCTIONS THOROUGHLY before proceeding.

#### **CAUTION**

Do not use one vent damper to control more than one heating appliance.

- A. Vent damper must be same size as outlet of vent supplied with boiler (see Table 3-2). Unpack damper carefully - DO NOT FORCE IT CLOSED! Forcing damper may damage motor and is not covered by warranty.

Insert pilot vent plug into gate and fold over tabs.

- B. Mount the vent damper assembly onto diverter. See damper manufacturer instructions for more information. Do not modify either diverter or vent damper. See Figure 6-1.

**NOTICE:** Provide adequate access for servicing.

- C. Locate vent damper position indicator to be visible following installation. See Figure 6-2.
- D. Plug vent damper connector into damper motor polarized receptacle.

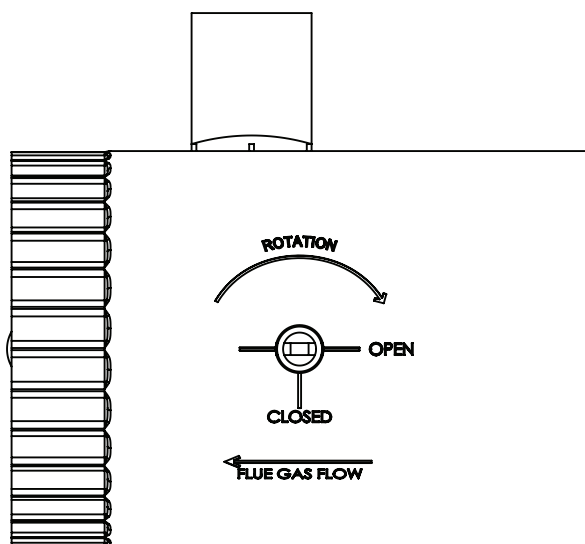


Figure 6-2: Vent Damper Position Indicator (shown in open position)

2. Install rear air dam.

Hang air dam on screws located at back of boiler. See Figure 6-1 for location.

#### **WARNING**

This installation is not complete until rear air dam is installed. Product performance will be negatively affected if rear air dam is not installed which can cause severe personal injury or death.

3. Install Blocked Vent Switch (BVS). See Figure 6-1.
  - A. Attach BVS to diverter using supplied #6 sheet metal screws.
  - B. Attach Black/White (BVS) and Black (BVS/FRS) quick connects to BVS. Wires are interchangeable.
4. Install vent piping.
  - A. See Figure 3-4 for vent sizes and locations. See Figure 4-2 for clearances.
  - B. Install vent piping from vent damper outlet to chimney. See Figure 6-3 for typical vent installation.

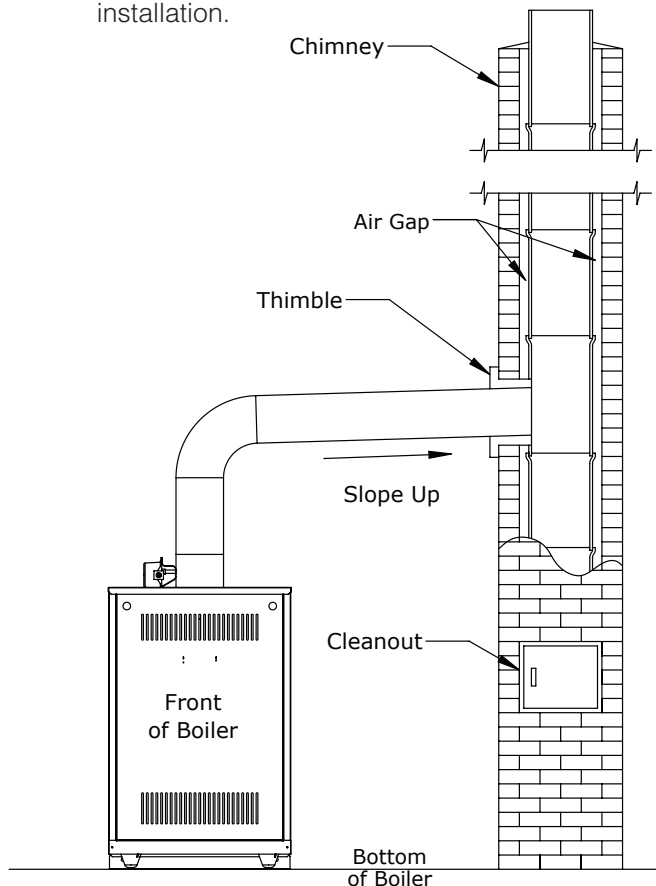


Figure 6-3: Typical Single Draft Hood Installation 49-075S through 49-299S



## 6 Venting *(continued)*

### Dual Draft Hood System

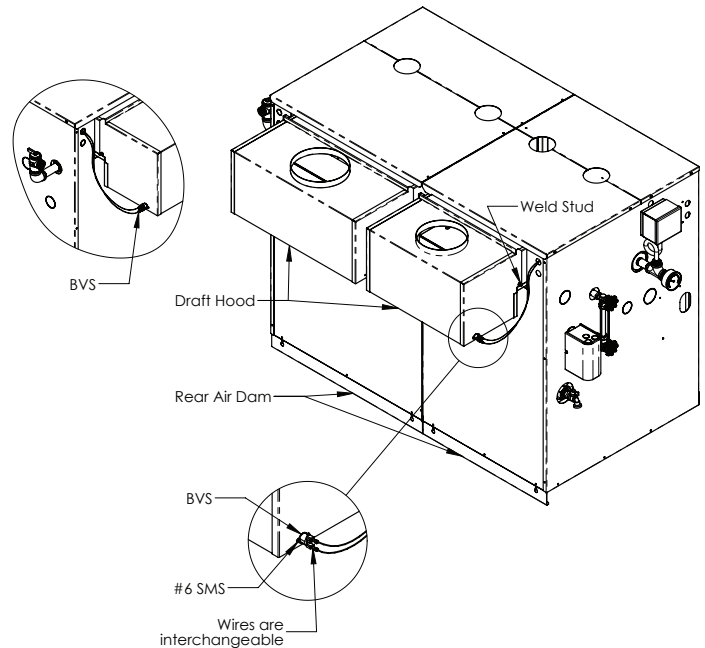
#### (49-350S - 49-550S)

1. Install rear air dams. Hang air dams on screws located at back of boiler. See Figure 6-5 for reference.

#### **WARNING**

This installation is not complete until rear air dams are installed. Product performance will be negatively affected if rear air dams are not installed which can cause severe personal injury or death.

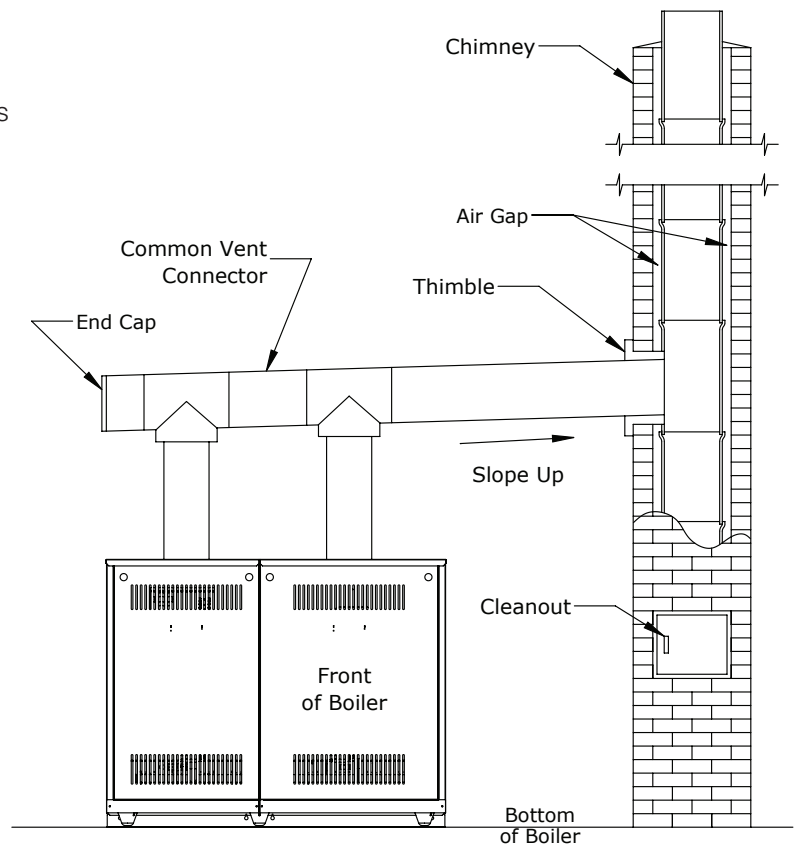
2. Install Blocked Vent Switches (BVS).
  - A. Attached one BVS to each diverter using supplied #6 sheet metal screws. See Figure 6-5.
  - B. Attached Black/White (BVS) and Black (BVS/FRS) quick connects to right BVS. Wires are interchangeable.
  - C. Attach Black (BVS/FRS) and White (BVS/Relay) quick connects to left BVS. Wire are interchangeable.
3. Install vent piping.
  - A. See Figure 3-5 and Table 6-4 for vent sizes and locations. See Figure 4-3 for clearances.
  - B. Install vent piping from vent damper outlets to chimney. See Figure 6-6 for typical vent installation.



**Figure 6-5: Typical Vent Installation  
49-350S through 49-550S**

**Table 6-4: Common Vent Connector Sizes**

Model	Minimum Common Vent Connector Inside Diameter (in)
49-350S	9
49-399S	9
49-450S	10
49-500S	10
49-550S	12



**Figure 6-6: Typical Dual Draft Hood Installation  
49-350S through 49-550S**

## 7 Steam Piping

### WARNING

- Do not use softened water in steam boilers. Accelerated boiler corrosion will result. Tie in fresh water supply to boiler upstream of a water softener.
- Oxygen contamination of boiler water will cause corrosion of iron and steel boiler components, and can lead to boiler failure. Check for and correct system leaks.

#### **NOTICE:**

Do not use copper for steam piping for the following reasons:

1. High coefficient of thermal expansion can induce mechanical stresses and cause expansion/ contraction noises if not accounted for in piping system design and installation.
2. High heat transfer rate (heat loss) of uninsulated copper piping must be included in normal piping and pickup factors used to size the boiler.
3. Soldering or brazing pastes and fluxes that end up in the system can cause poor heat transfer, surging, an unsteady water line and wet steam if not thoroughly removed during the skimming procedure.
4. Galvanic corrosion of adjoining metal may occur due to dissimilar metals in certain water chemistry if dielectric unions are not used.

### **General Piping Notes**

Primary purpose of this near boiler piping is to separate tiny water droplets from steam exiting the boiler so that “dry” steam is sent to distribution system. If near boiler piping is not correct, wet steam will enter distribution system and the following problems may occur:

- Short cycling on low water in boiler
- Boiler or system flooding
- Water hammer
- Failure to heat one or more radiators

Avoid three common piping mistakes shown in Figure 7-1. This applies even if existing boiler has one of the piping mistakes shown in Figure 7-1 and appears to be working. If two or more steam mains must be connected to boiler, connect a separate take-off for each main into the header between riser(s) and equalizer. Also note the following points:

1. A size reduction must be made to connect header and equalizer. This reduction must be made in the equalizer line. Do not make this size reduction in the horizontal header.
2. One pipe steam systems require air vents on each radiator, as well as at the end of each main. For system to work properly, these vents must be properly installed, sized, and be in good condition. Inspect and replace any defective vents. If there are no vents at ends of the mains, install them.
3. For installations with condensate or boiler feed pumps, follow pump manufacturer’s piping instructions. Such systems generally do not require Hartford loops.
4. Do not use a check valve in place of, or in addition to, a Hartford loop on a gravity return system.
5. Pipe fill connection from a clean source of water. When water supply is from a well, make sure that a strainer is installed in the well system.

## 7 Steam Piping (continued)

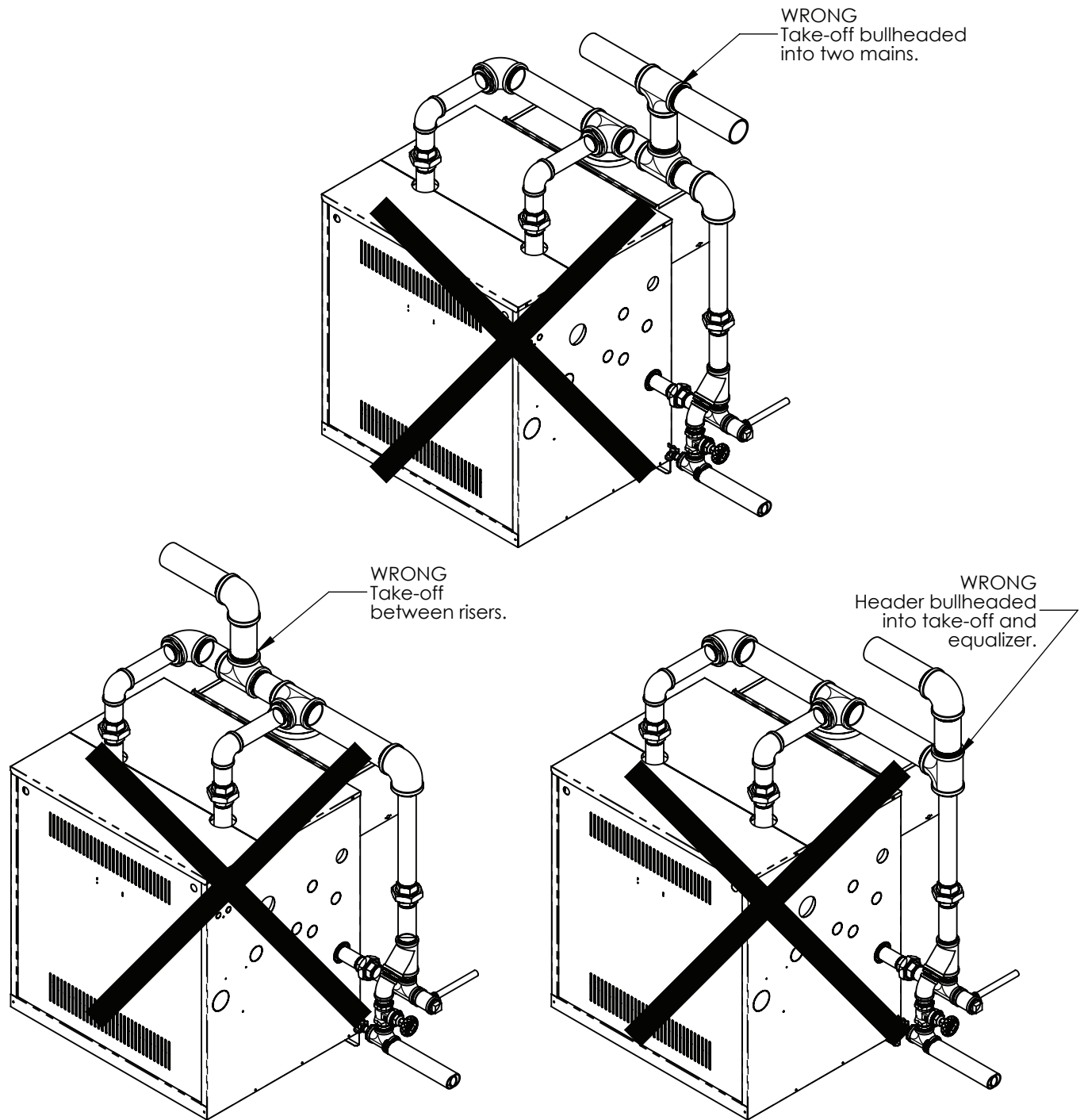


Figure 7-1: Common Near Boiler Piping Mistakes

## 7 Steam Piping *(continued)*

### **Near Boiler Piping**

1. Evaluate existing steam system.

Single most important factor in determining expected life cycle of a steam boiler is the amount of fresh water added to boiler during operation. Fresh water brings minerals and oxygen into the boiler. These contaminants greatly accelerate corrosion of cast iron boiler sections.

Assure all system radiators, piping and vents are absolutely leak tight.

- A. When a steam boiler is installed in an existing system, ALL air vents should be replaced at the same time. This assures the new boiler will not be compromised by existing system leaks.
  - B. If system contains hidden supply or return piping (hidden behind walls, buried in concrete, etc.) pressure test this piping to assure there are no leaks.
2. Repair any leaks in the system.
  3. Install accurate water meter with counter on fresh water supply to boiler.

### **⚠ DANGER**

- Pipe relief valve discharge to a safe location.
- Do not install any valves between boiler and relief valve.
- Do not install any valves between relief valve and discharge.
- Do not move relief valve from factory location.
- Do not plug relief valve discharge.
- Do not install a relief valve with a setting greater than 15 psi.

4. Remove parts carton from boiler crate.
5. Install relief valve (spindle must be in vertical position) into tapping on boiler right side using nipple and elbow supplied. See Figures 3-4 and 3-5, 3-6, and Table 3-7.

### **⚠ WARNING**

- Pipe discharge of relief valve to a location where water or steam will not create a hazard or cause property damage if the relief valve opens.
  - End of discharge pipe must terminate in an unthreaded pipe.
  - If relief valve discharge is not piped to a drain it must terminate at least 6 inches above floor.
  - Termination of the relief valve discharge piping must be in an area where it is not likely to become plugged by debris or subjected to freezing.
6. Install drain valve into tapping on boiler left side using 2 x 3/4 bushing provided. See Figures 3-4, 3-5, 3-6 and Table 3-7.
  7. See Figure 7-2 for near boiler piping of Hartford Loop.

### **Indirect Water Heater**

All Series 49 boilers are equipped with tappings to permit connection of an indirect water heater (IWH). See Appendix B for installation.

# 7 Steam Piping (continued)

	49-075S thru 49-150S	49-175S thru 49-299S	49-350S and 49-399S	49-450S thru 49-550S
# Sections	3 & 4	5, 6 & 7	8 & 9	10, 11 & 12
A <sup>1</sup>	(1) 2	(2) 2	(3) 2	(4) 2
B	2	3	4	4
C	1-1/2	2	2	2
D	1-1/4	1-1/2	1-1/2	1-1/2

<sup>1</sup> (3) 2 indicates three 2 inch risers

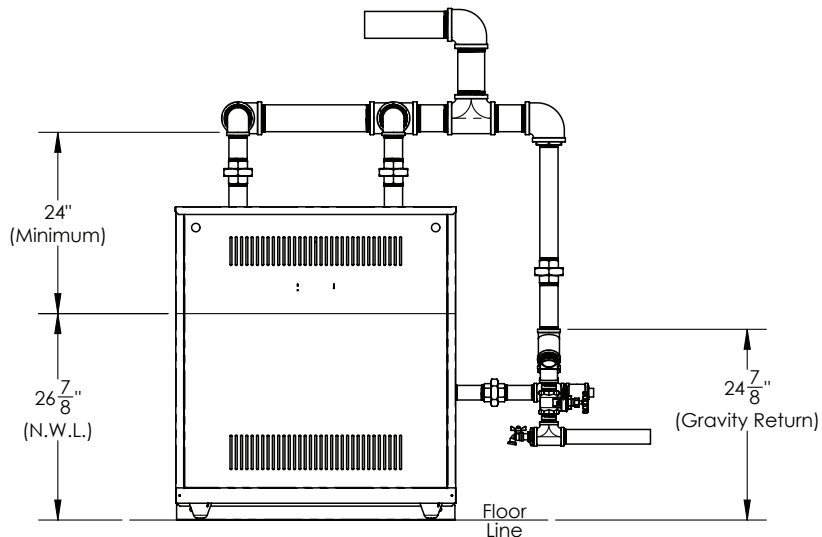
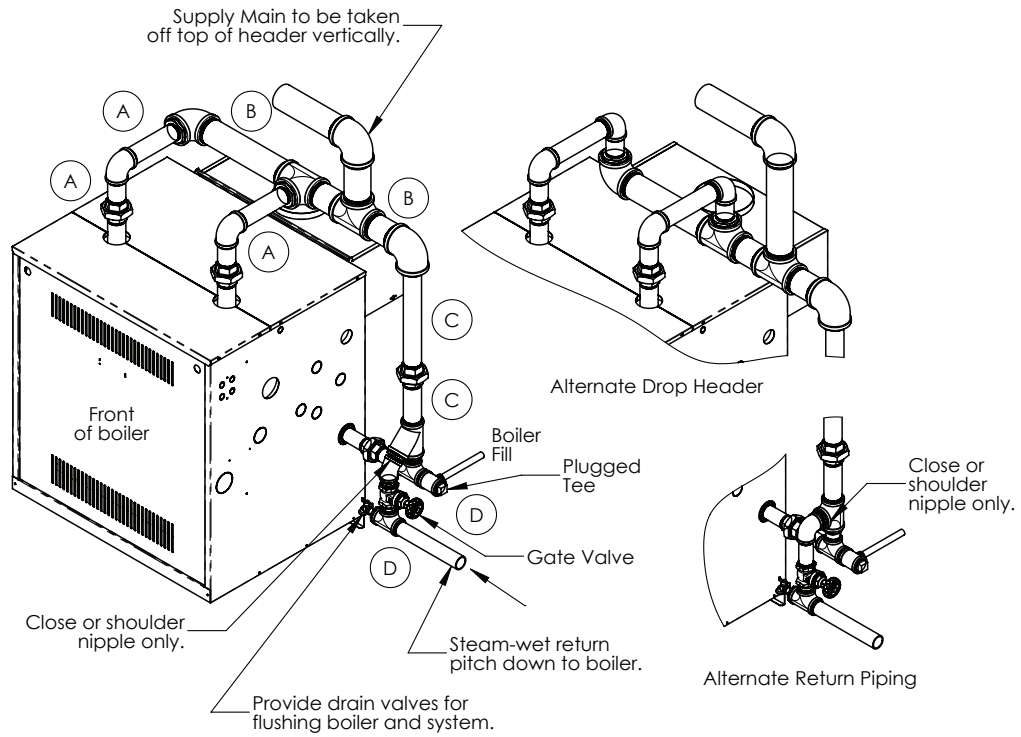


Figure 7-2: Near Boiler Piping of Hartford Loop

## 8 Gas Piping

1. Size gas piping. Design system to provide adequate gas supply to boiler. Consider these factors:
  - A. Allowable pressure drop from point of delivery to boiler. Maximum allowable system pressure is  $\frac{1}{2}$  psig. Minimum gas valve inlet pressure is listed on rating label. Also see Table 8-1.

**Table 8-1: Gas Pressure**

Natural Gas	Inlet Min (in. wc.)	Inlet Max (in. wc.)	Manifold (in. wc.)
All Sizes	4.0	14.0	3.5

- B. Maximum gas demand. Consider existing and expected future gas fired equipment (i.e. water heater, cooking equipment, etc.)
2. Connect boiler to gas supply system.
  - A. See Figures 8-3 and 8-4 for gas manifold and control assembly configurations.
  - B. Use methods and materials in accordance with local plumbing codes and requirements of gas supplier. In absence of such requirements, follow *National Fuel Gas Code, ANSI Z223.1/NFPA 54*.
  - C. Use thread compounds (pipe dope) resistant to action of liquefied petroleum gas.
  - D. Install sediment trap, ground-joint union and manual shut-off valve upstream of combination gas valve (within 6 ft. of boiler). See Figure 8-2

### ⚠ WARNING

#### Explosion Hazard.

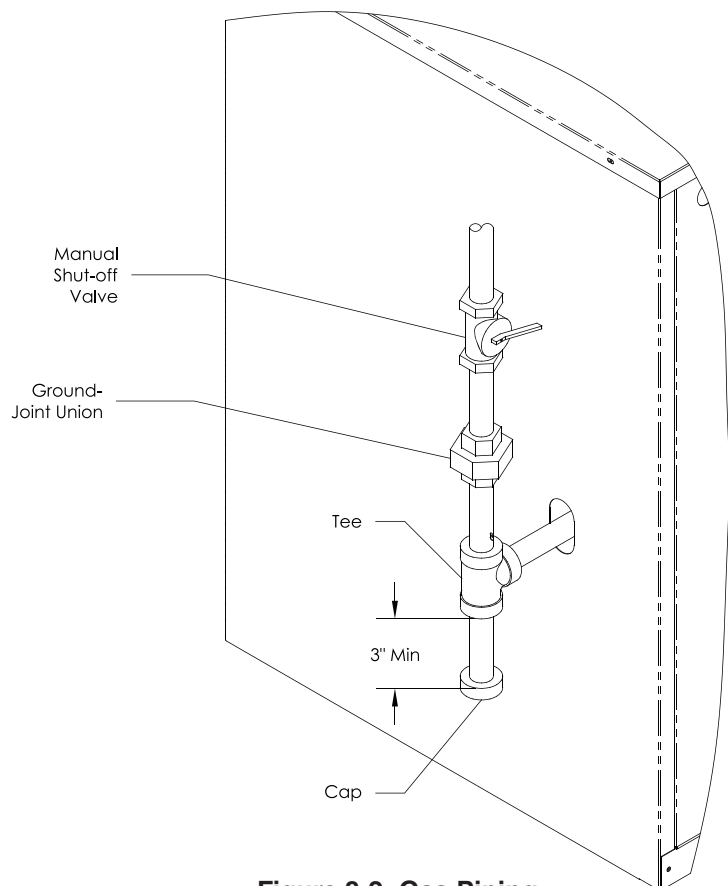
- Failure to properly pipe gas supply to boiler could cause improper operation or leaks of flammable gas resulting in severe personal injury, death or substantial property damage.
- Gas supply to boiler and system must be shut off prior to installing or servicing boiler gas piping.

### ⚠ DANGER

#### Explosion Hazard.

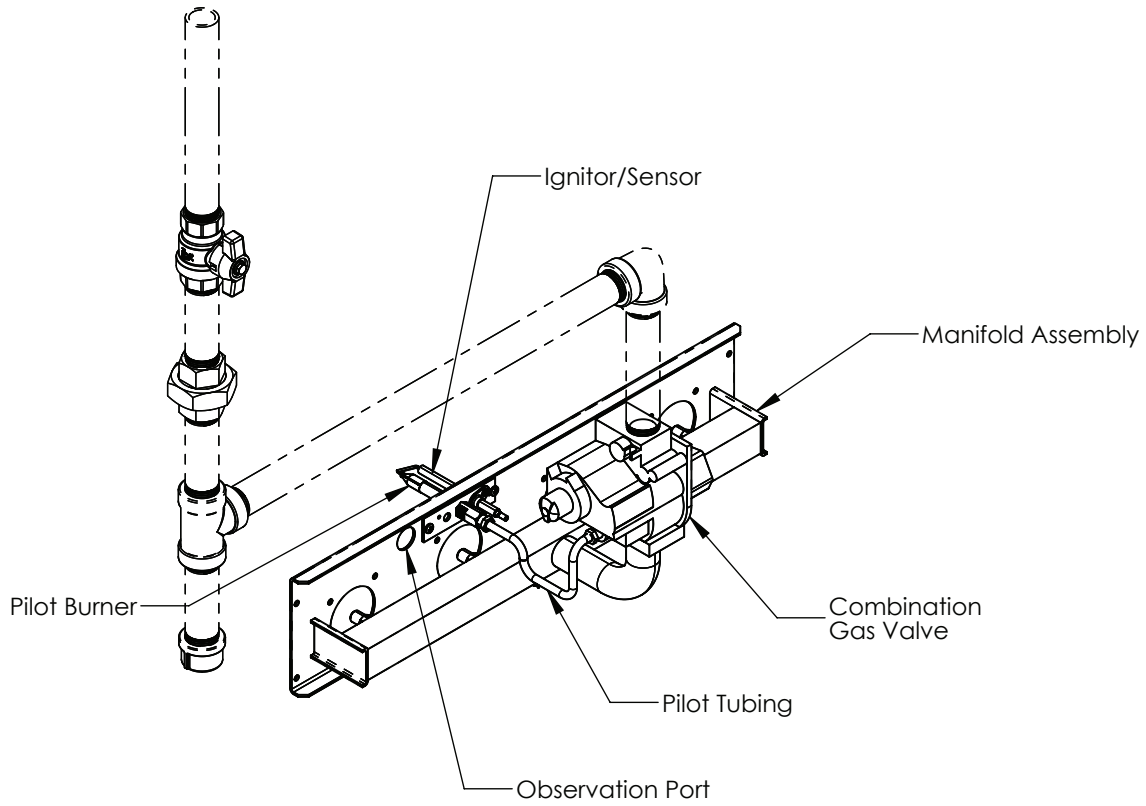
Do not use matches, candles, open flames or other ignition sources to check for leaks. Failure to comply could result in severe personal injury, death or substantial property damage.

- E. All above ground gas piping upstream from manual shut-off valve must be electrically continuous and bonded to a grounding electrode. Do not use gas piping as grounding electrode. Refer to *National Electrical Code, ANSI/NFPA 70*.
3. Pressure test gas connection before placing boiler in operation. Follow *National Fuel Gas Code, ANSI Z223.1/NFPA 54*.

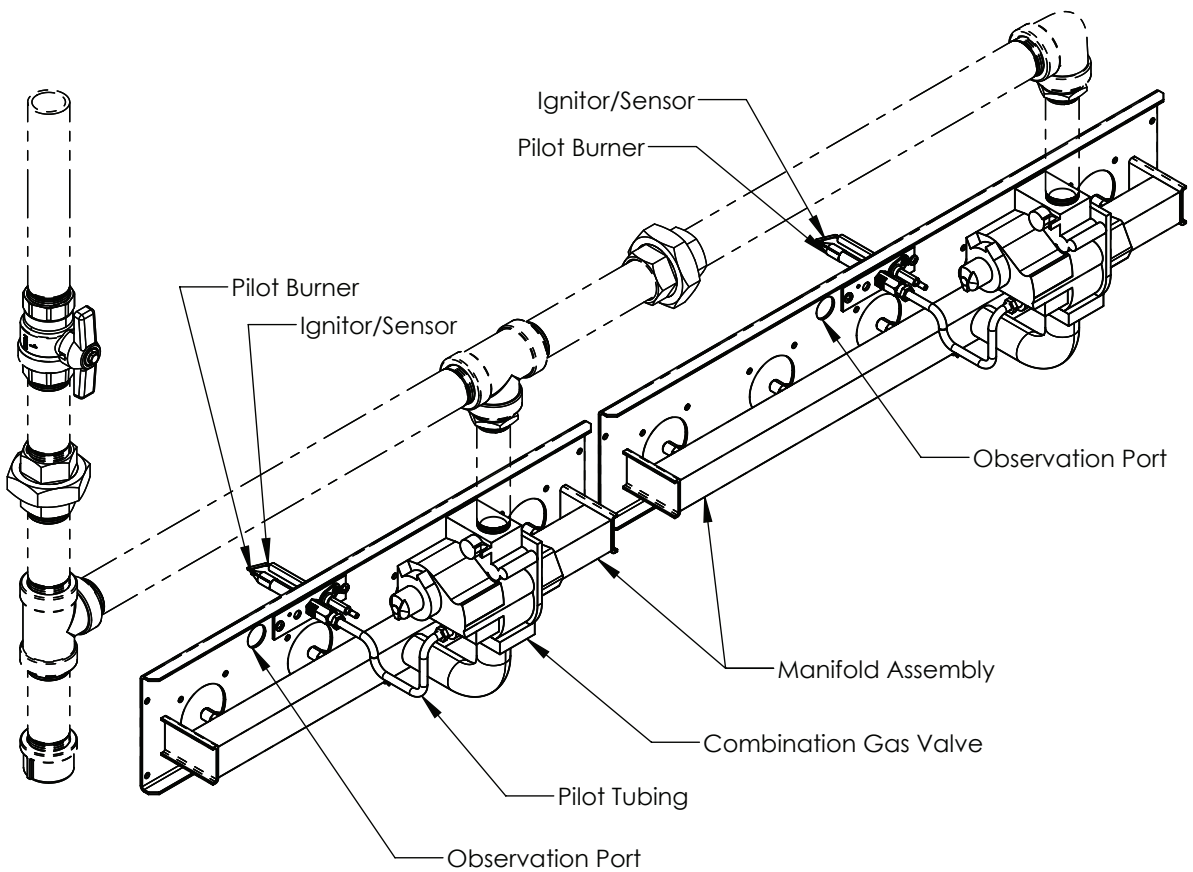


**Figure 8-2: Gas Piping**

# 8 Gas Piping *(continued)*



**Figure 8-3: 49-075S through 49-299S Gas Manifold and Control Assembly Single Combination Gas Valve**



**Figure 8-4: 49-350S through 49-550S Gas Manifold and Control Assembly Dual Combination Gas Valves**

## 9 Electrical

### WARNING

**Electrical Shock Hazard.** Wiring errors can cause improper or dangerous operation. Verify proper operation after installation.

1. Install wiring so boiler is electrically bonded to ground in accordance with requirements of authority having jurisdiction, or in absence of such requirements, with the *National Electrical Code*, ANSI/NFPA 70.
2. Install thermostat per manufacturer's instructions.
3. Wire boiler. Boiler is rated for 120 VAC, 60 HZ, less than 12 A. A separate electrical circuit must be run from main electrical service with an over-current device/disconnect in the circuit. A service switch is recommended and may be required by some local jurisdictions. Connect to black and white wires and green ground screw. See Figures 9-1, 9-3, and 9-5.

**NOTICE:** Do not tamper with factory wiring and do not fire 49-350S, 49-399S, 49-450S, 49-500S and 49-550S bases individually. Doing so will result in poor performance due to significant reduction in heat output.

### DANGER

**Electrical Shock Hazard.**

- Disconnect electrical supply before installing or performing maintenance.
- Electrical power may be supplied from more than one circuit.
- Lock out all electrical boxes with padlock once power is turned off.

### WARNING

**Electrical Shock Hazard.**

- All wiring and grounding must conform to requirements of authority having jurisdiction or, in absence of such requirements, to *National Electrical Code/NFPA 70*.
- Make electrical connections according to boiler's wiring diagram and instructions. Failure to properly wire electrical connections to the boiler may result in severe personal injury, death or substantial property damage.
  - Protect each boiler circuit with a properly sized over-current device.
  - Never jump out or bypass any operating control or component of this boiler.



# 9 Electrical (continued)

- Notes:
1. If any of the original wire supplied with the appliance must be replaced, it must be replaced with the same type shown or its equivalent.
  2. Install over-current protection in accordance with Authority Having Jurisdiction or, in the absence of such requirements, follow The National Electric Code, NFPA 70. Do not provide over-current protection greater than 15 Amperes.

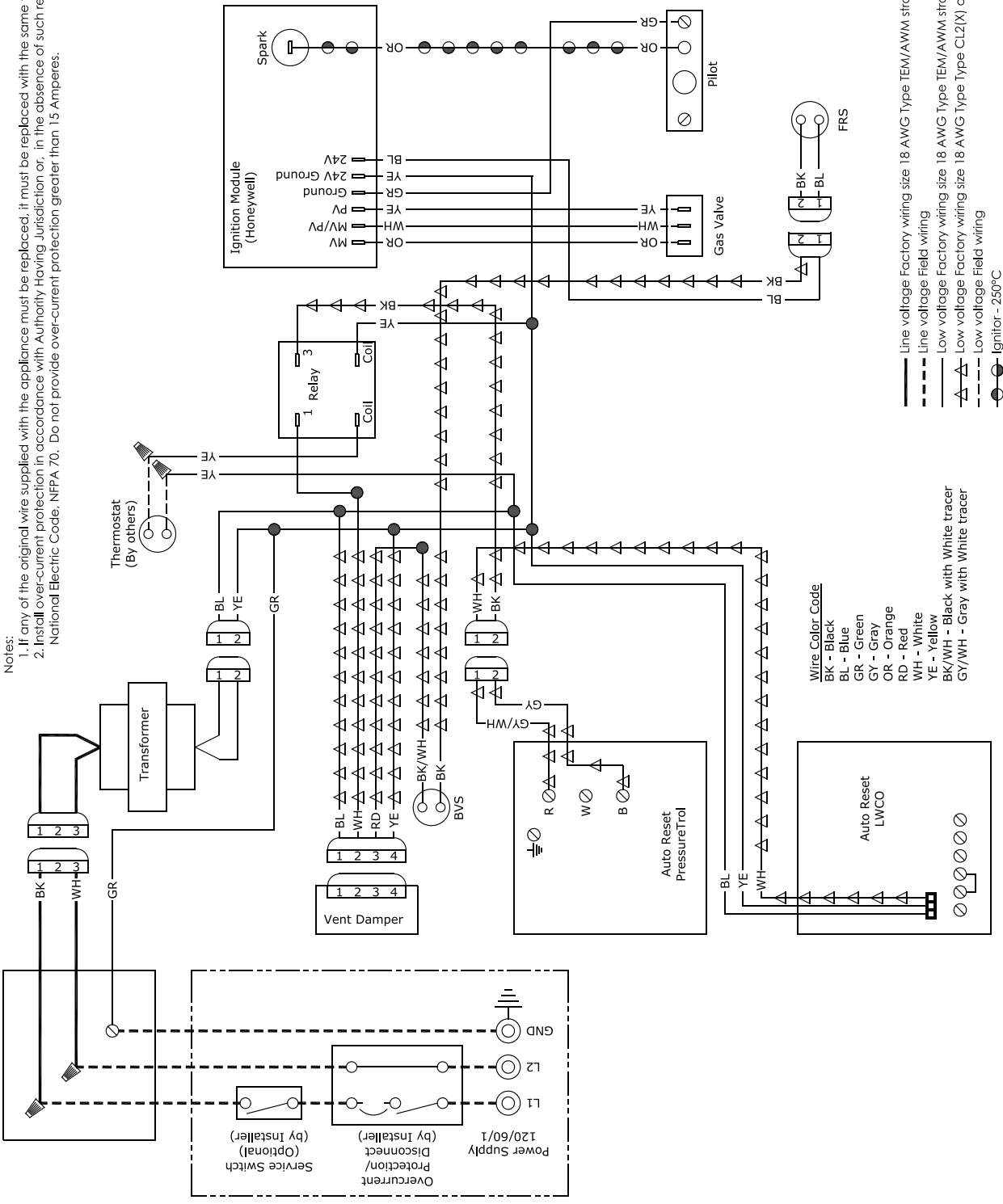


Figure 9-1: Wiring Diagram 49-075S through 49-299S

# 9 Electrical *(continued)*

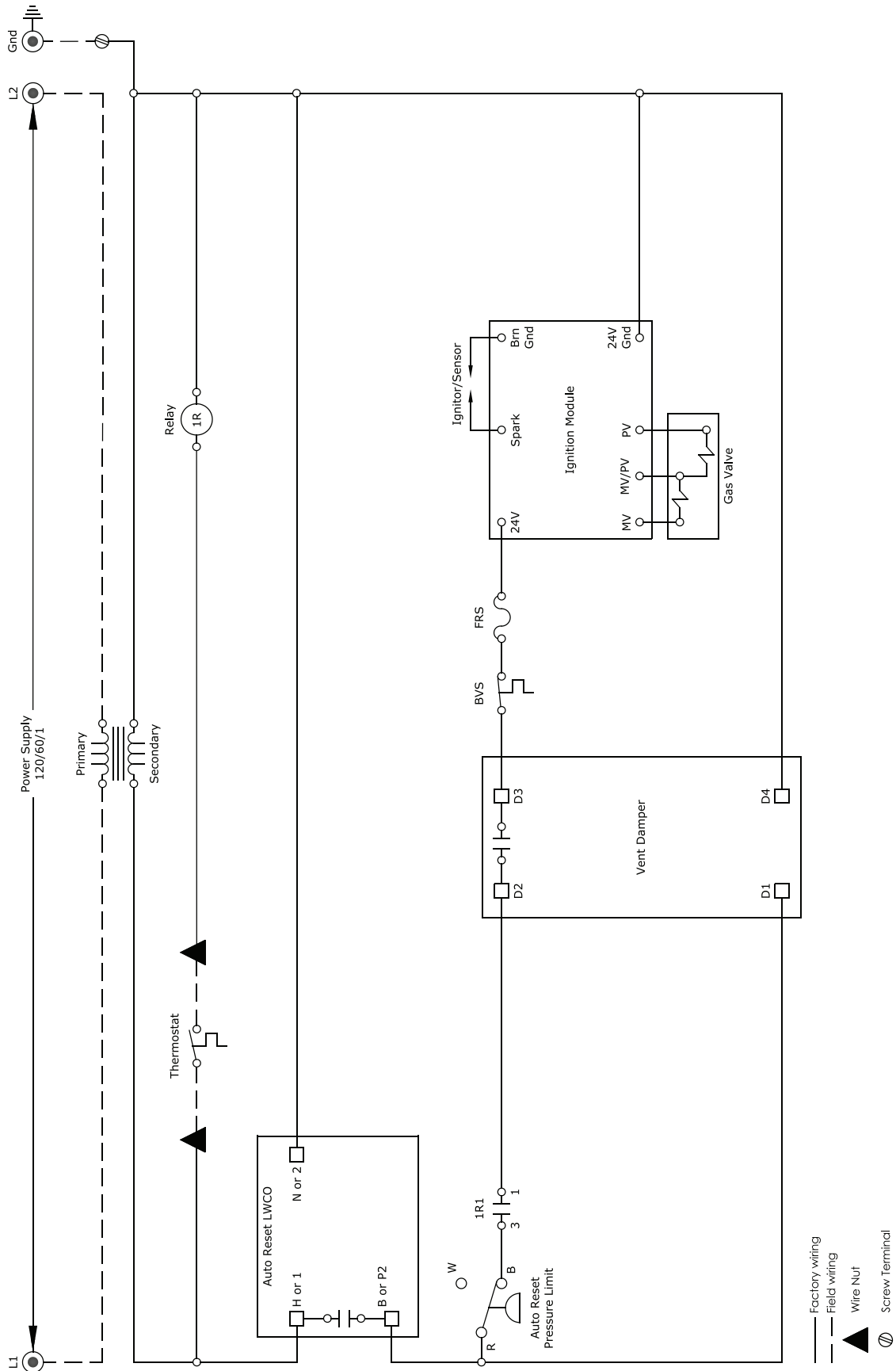


Figure 9-2: Ladder Diagram 49-075S through 49-299S

# 9 Electrical *(continued)*

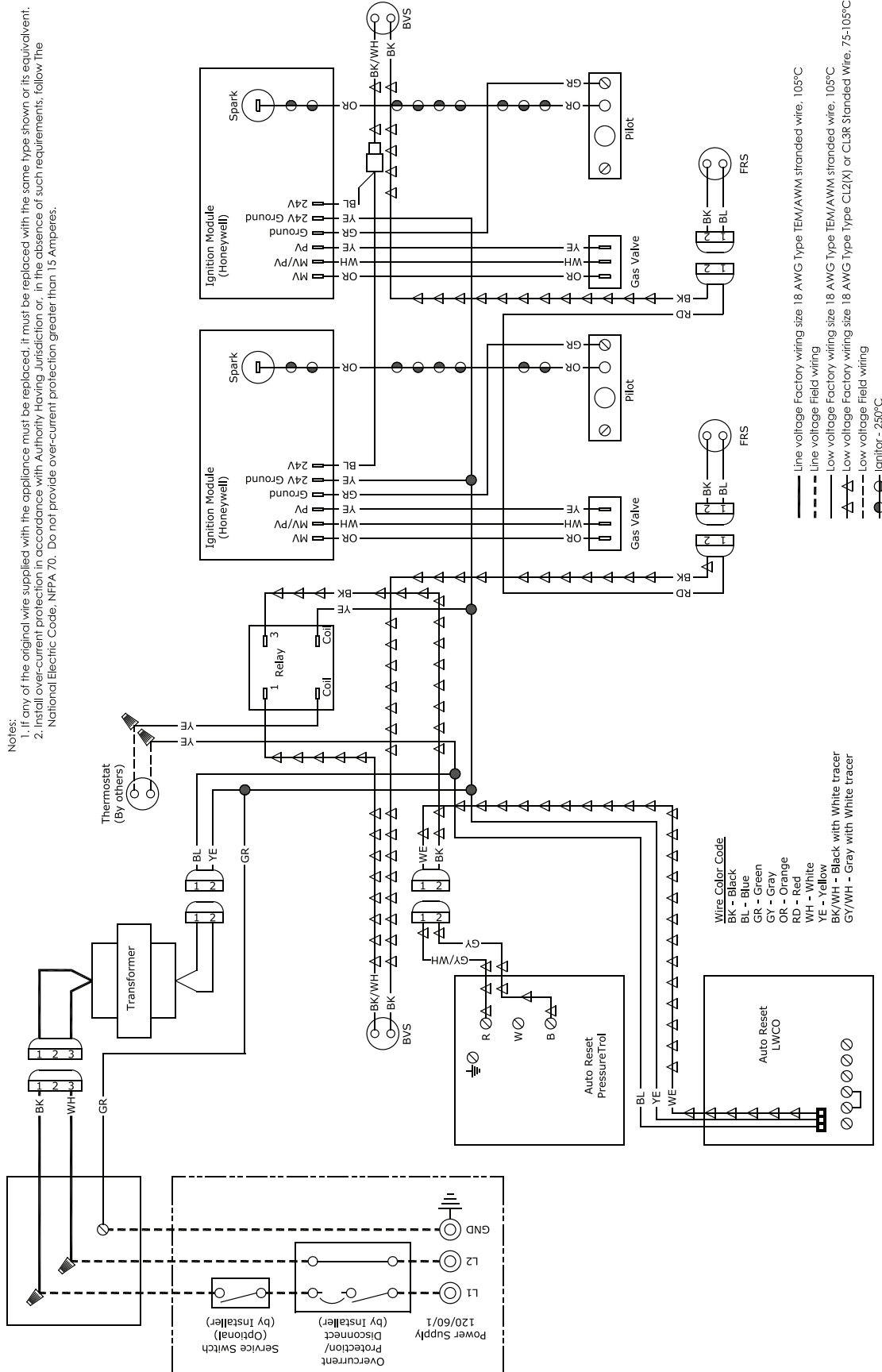


Figure 9-3: Wiring Diagram 49-350S through 49-550S, Non CSD-1

# 9 Electrical *(continued)*

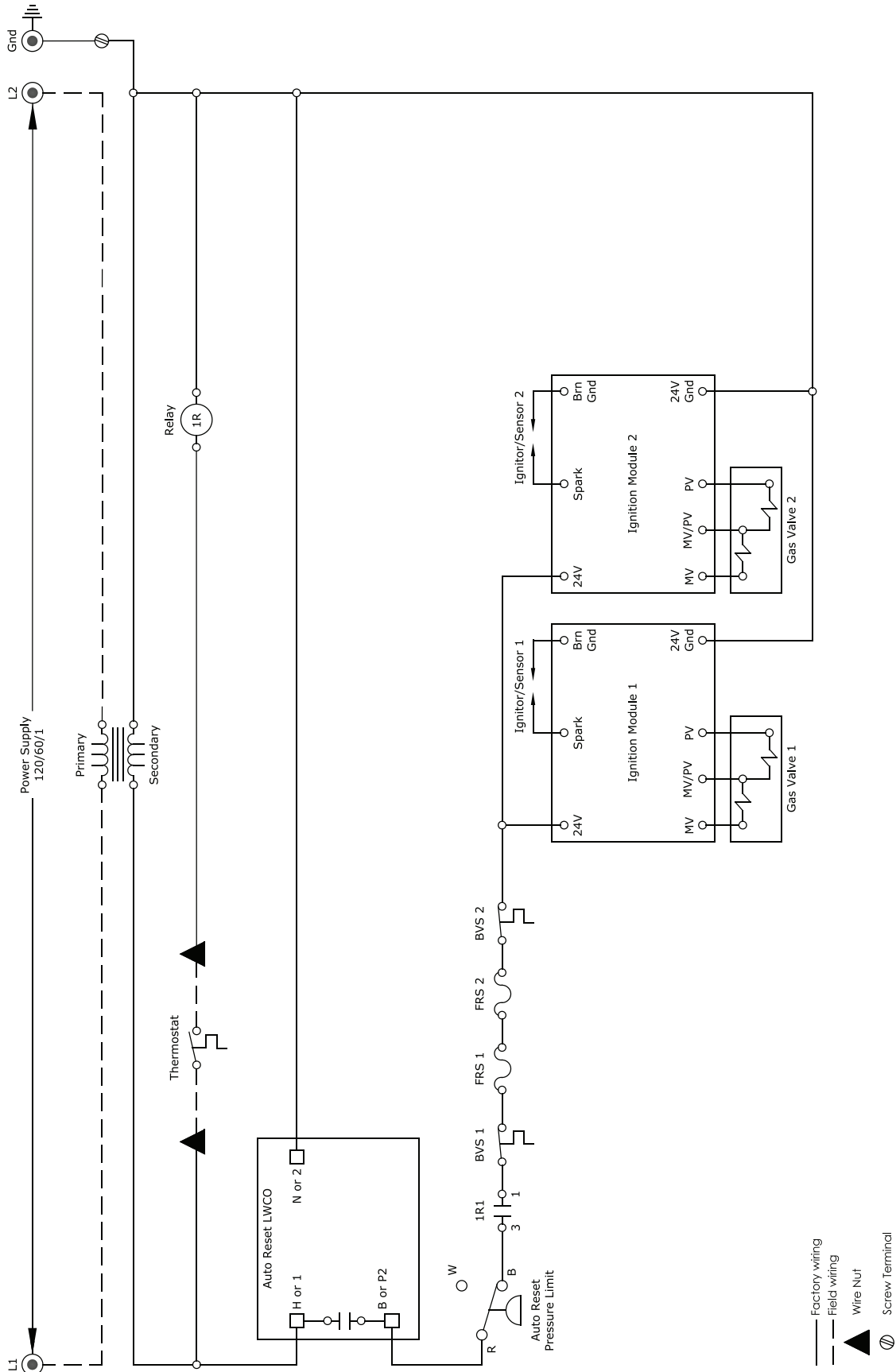
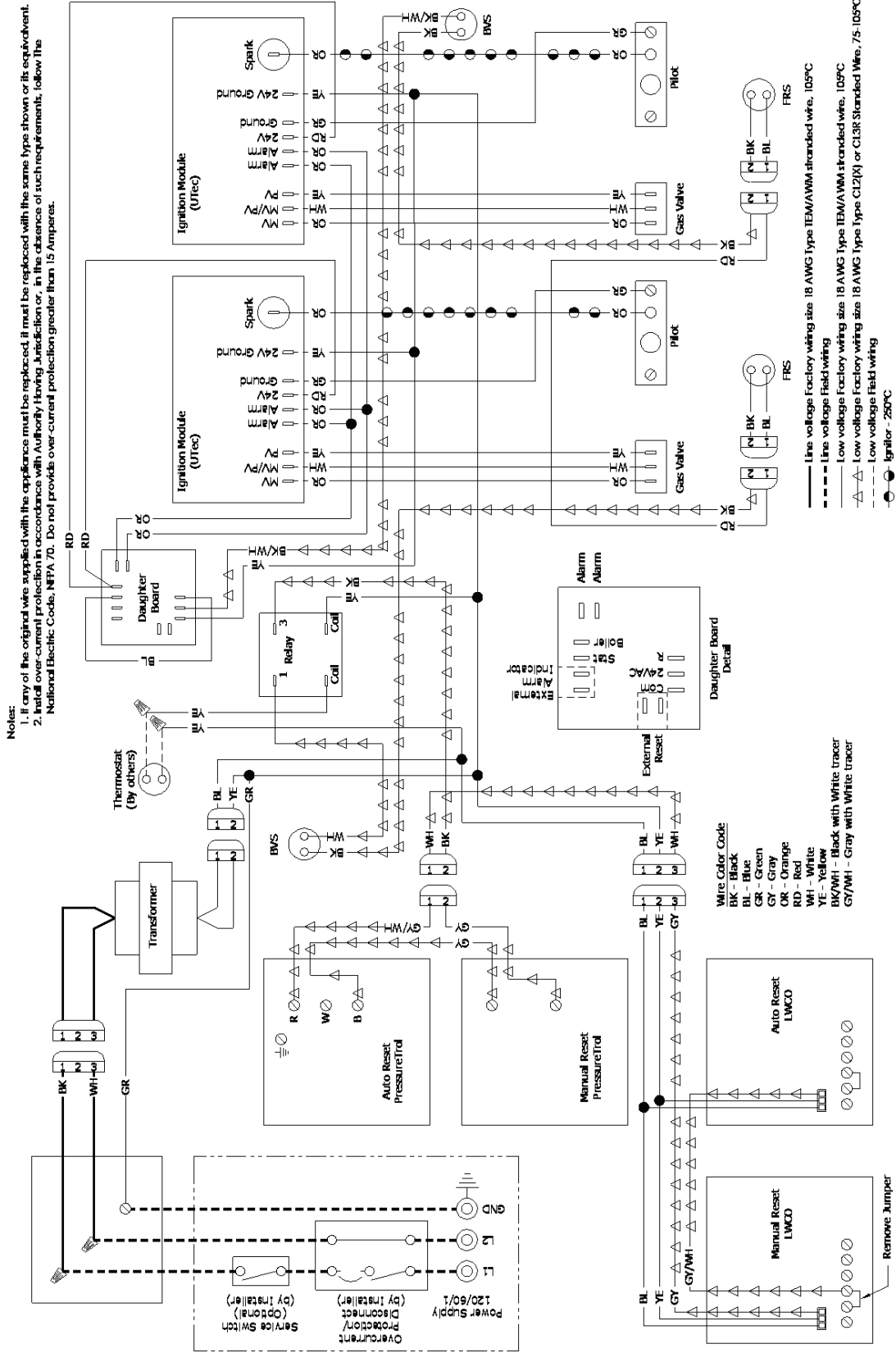


Figure 9-4: Ladder Diagram 49-350S through 49-550S, NON CSD-1

# 9 Electrical *(continued)*



Notes:

1. If any of the original wire supplied with the appliance must be replaced, it must be replaced with the same type shown or its equivalent.
2. Install over-current protection in accordance with Authority Having Jurisdiction or, in the absence of such requirements, follow the National Electric Code, NFPA 70. Do not provide over-current protection greater than 15 Amperes.

Figure 9-5: Wiring Diagram 49-450S through 49-550S, CSD-1



# 10 System Start-Up and Checkout

## DANGER

**Explosion Hazard.** Do not use matches, candles, open flames or other ignition source to check for leaks. Failure to comply could result in severe personal injury, death or substantial property damage.

## WARNING

- Make sure that the area around the boiler is clear and free from combustible materials, gasoline, and other flammable vapors and liquids.
- Damper must be in open position when appliance main burner is operating.

### Standard Configuration

#### (49-075S - 49-399S and 49-450S - 49-550S, Non CSD-1)

1. Make sure boiler is filled with water to the NWL (26 5/8 inches above floor or pad on which the boiler is installed)
2. Check all new gas piping for leaks and purge piping sections that are filled with air in accordance with *National Fuel Gas Code*, ANSI Z223.1/NFPA 54.
3. Verify vent system is complete and free of obstructions before attempting to fire boiler.
4. Inspect all wiring for loose or uninsulated connections.
5. Make sure main burners are secured to manifold assembly and insulation is in place.
6. Adjust auto reset pressure limit for a 2 psi **MAIN** and 1.5 psi **DIFF**.
7. Adjust thermostat to highest setting.
8. Start the boiler using Operating Instructions. See Figure 10-1.
9. Upon initial start-up, gas train will be filled with air. Even if gas line has been completely purged of air, it may take several tries for ignition before a flame is established. Once a flame has been established for the first time, subsequent calls for burner operation should result in a flame on first try.
10. Observe pilot burner flame visible through observation port. See Figure 10-2 for front door removal. A steady medium blue flame will cover ignitor/sensor. See Figure 10-3.
11. Minimum steady state pilot flame signal must be 1  $\mu$ A (microampere) DC (direct current). For reliable operation, flame signal should be 2  $\mu$ A or greater. Flame current can be determined by flashing green **STATUS** LED on ignition module. See Table 10-4.
12. Make sure vent damper, if equipped, is in open position when main burners are firing. See Figure 6-2.
13. Observe main burner flames visible through the observation port. Flames should be stable and mostly blue. See Figure 10-5. No yellow tipping should be present; however, intermittent flecks of yellow and orange in the flame are normal.
14. Check entire gas train for leaks using approved leak detection method while boiler is firing. Fix any leaks found immediately.
15. Conduct combination gas valve shutdown test. With main burners firing, disconnect ignition cable from ignition module. Both pilot and main burners should stop firing.
16. Reconnect ignition cable. Both pilot and main burners should relight.
17. For boilers with dual combination gas valves, steps 10 through 16 must be completed for both valves and their respective pilot and main burner assemblies.

# 10 System Start-Up and Checkout *(continued)*

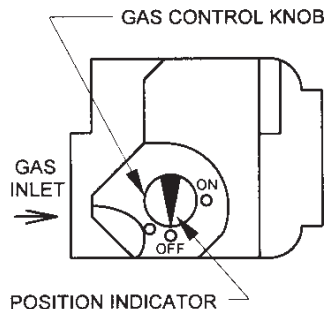
## FOR YOUR SAFETY READ BEFORE OPERATING

**WARNING:** If you do not follow these instructions exactly, a fire or explosion may result causing property damage, personal injury, or loss of life.

- A. This appliance is equipped with an ignition device which automatically lights the pilot. Do not try to light the pilot by hand.
- B. BEFORE OPERATING smell all around the appliance area for gas. Be sure to smell next to the floor because some gas is heavier than air and will settle on the floor.
- WHAT TO DO IF YOU SMELL GAS**
- ▶ Do not try to light any appliance.
  - ▶ Do not touch any electric switch; do not use any phone in your building.
  - ▶ Immediately call your gas supplier from a neighbor's phone. Follow the gas supplier's instructions.
- C. Use only your hand to push in or turn the gas control knob. Never use tools. If the knob will not push in or turn by hand, don't try to repair it, call a qualified service technician. Force or attempted repair may result in a fire or explosion.
- D. Do not use this appliance if any part has been under water. Immediately call a qualified service technician to inspect the appliance and to replace any part of the control system and any gas control which has been under water.
- ▶ If you cannot reach your gas supplier, call the fire department.

## OPERATING INSTRUCTIONS

1. STOP! Read the safety information above on this label.
2. Set the thermostat to lowest setting.
3. Turn off all electric power to the appliance.
4. This appliance is equipped with an ignition device which automatically lights the pilot. Do not try to light the pilot by hand.
5. Locate the gas control valve at the end of the gas supply pipe going into the boiler. The gas control knob is the brown or blue plastic knob located on top of the gas control valve.
6. Rotate gas control knob clockwise from "ON" position to "OFF". Make sure knob rests against stop.
7. Wait five (5) minutes to clear out any gas. Then smell for gas, including near the floor. If you smell gas, STOP! Follow "B" in the safety information above on this label. If you do not smell gas, go to the next step.
8. Rotate gas control knob counterclockwise from "OFF" to "ON". Make sure knob rest against stop. Do not force.
9. Turn on all electric power to the appliance.
10. Set thermostat to desired setting.
11. If the appliance will not operate, follow the instructions "TO TURN OFF GAS TO APPLIANCE" and call your service technician or gas supplier.



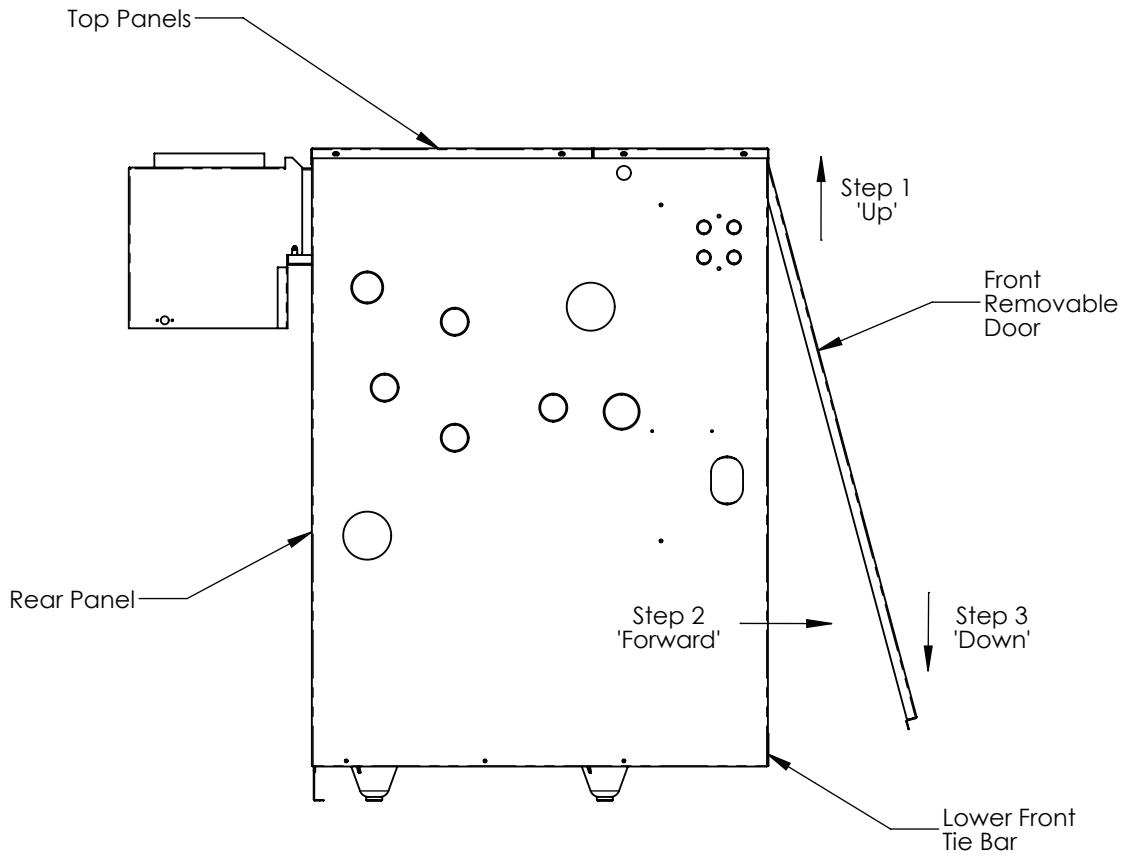
## TO TURN OFF GAS TO APPLIANCE

1. Set the thermostat to lowest setting.
2. Turn off all electric power to the appliance if service is to be performed.
3. Rotate gas control knob clockwise from "ON" position to "OFF". Make sure knob rests against stop.

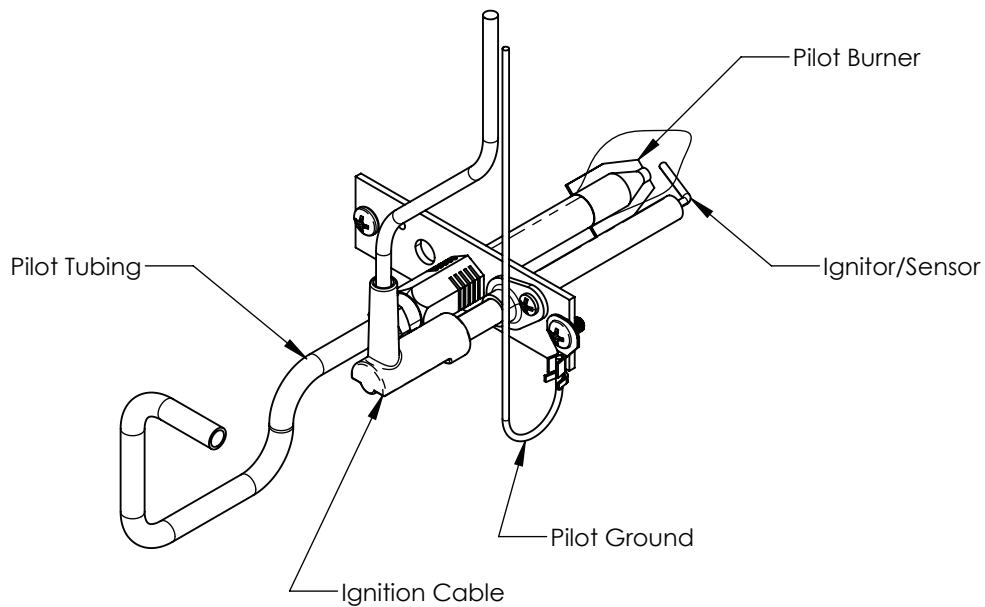
Figure 10-1: Operating Instructions



## 10 System Start-Up and Checkout *(continued)*

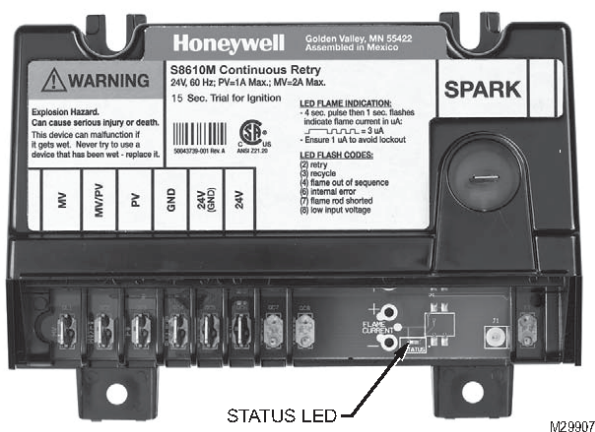


**Figure 10-2: Front Door Removal**



**Figure 10-3: Pilot Burner Flame**

## 10 System Start-Up and Checkout *(continued)*



M29907

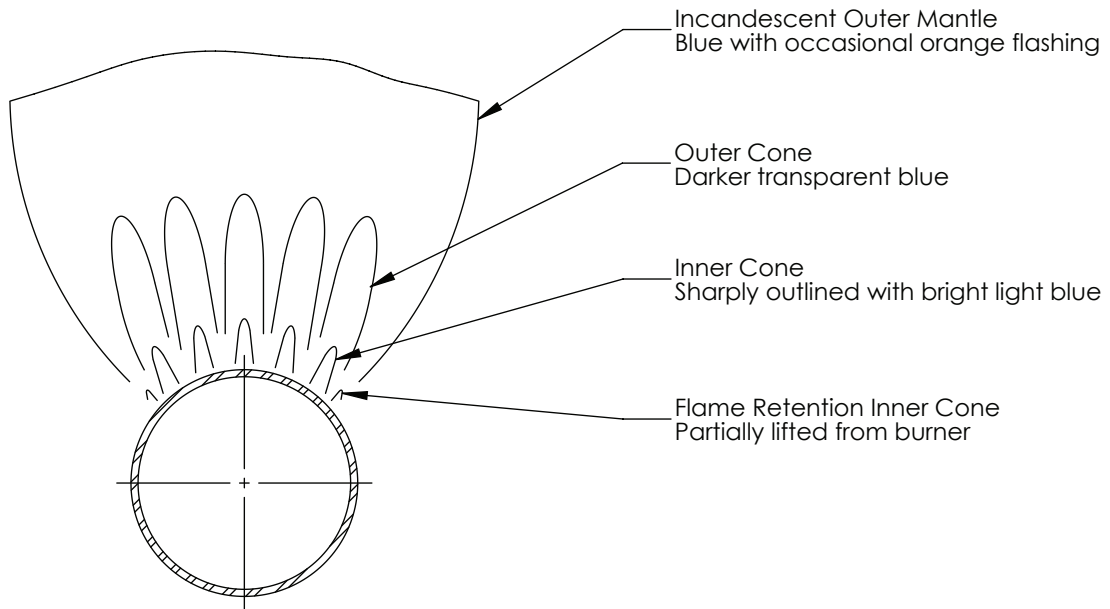
**Table 10-4: Green LED Status Codes**

Green LED Flash Code	Indicates	Next System Action	Recommended Service Action
OFF	No "Call for Heat"	N/A	None
Flash Fast	Power up - internal check	N/A	None
Heartbeat	Normal startup - ignition sequence started (including prepurge)	N/A	None
4 Seconds ON then "x" flashes	Device in run mode. "x" = flame current to the nearest $\mu$ A.	N/A	None
2	5 minute Retry Delay - Pilot flame not detected during trial for ignition	Initiate new trial for ignition after retry delay completed.	If system fails to light on next trial for ignition check gas supply, pilot burner, spark and flame sense wiring, flame rod contamination or out of position, burner ground connection.
3	Recycle - Flame failed during run	Initiate new trial for ignition. Flash code will remain through the ignition trial until flame is proved.	If system fails to light on next trial for ignition, check gas supply, pilot burner, flame sense wiring, contamination of flame rod, burner ground connection.
4	Flame sensed out of sequence	If situation self corrects within 10 seconds, control returns to normal sequence. If flame out of sequence remains longer than 10 seconds, control will resume normal operation 1 hour after error is corrected.	Check for pilot flame. Replace gas valve if pilot flame present. If no pilot flame, cycle "Call for Heat." If error repeats, replace control.
6	Control Internal Error	Control remains in wait mode. When the fault corrects, control resumes normal operation.	Cycle "Call for Heat". If error repeats, replace control.
7	Flame rod shorted to ground	Control remains in wait mode. When the fault corrects, control resumes normal operation.	Check flame sense lead wire for damage or shorting. Check that flame rod is in proper position. Check flame rod ceramic for cracks, damage or tracking.
8	Low secondary voltage supply- (below 15.5 VAC)	Control remains in wait mode. When the fault corrects, control resumes normal operation.	Check transformer and AC line for proper input voltage to the control. Check with full system load on the transformer.

<sup>a</sup>Flash Code Descriptions:

- Flash Fast: rapid blinking
- Heartbeat: Constant  $\frac{1}{2}$  second bright,  $\frac{1}{2}$  second dim cycles.
- 4 second solid on pulse followed by "x" 1 second flashes indicates flame current to the nearest  $\mu$ A. This is only available in run mode.
- A single flash code number signifies that the LED flashes X times, remains off for two seconds, and then repeats the sequence.

# 10 System Start-Up and Checkout *(continued)*



**Figure 10-5: Main Burner Flame**

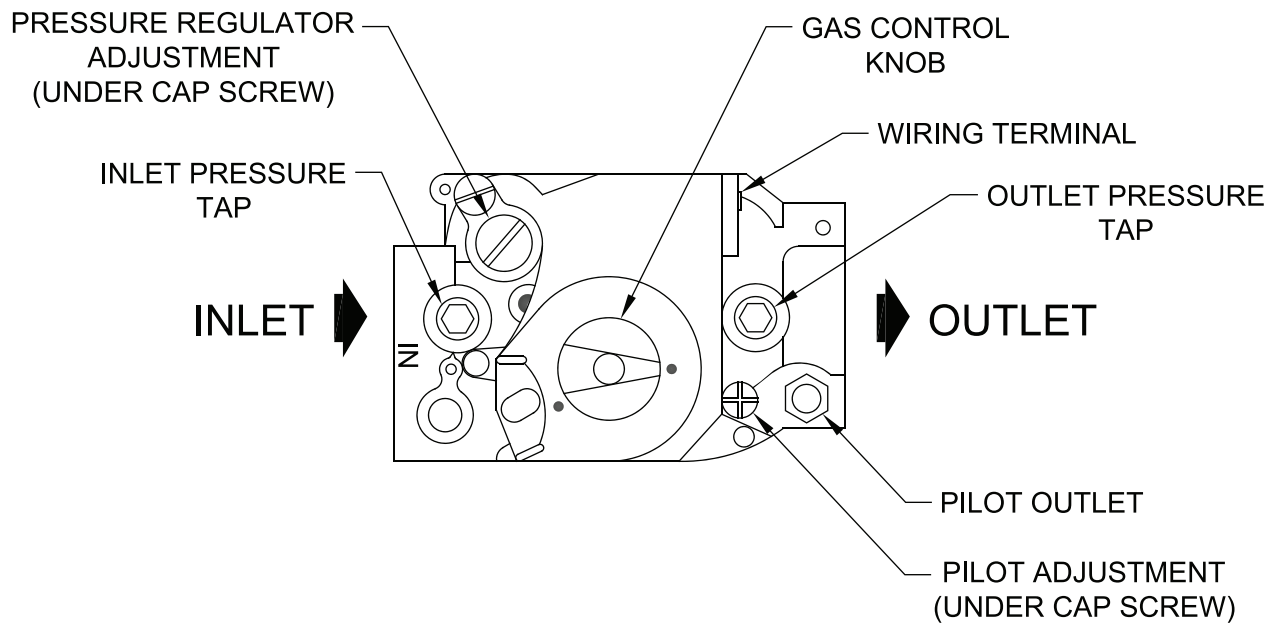
## 10 System Start-Up and Checkout *(continued)*

### WARNING

Failure to follow the following procedure exactly could result in over firing of boiler and a carbon monoxide hazard.

18. Check gas Inlet pressure
  - A. While boiler and all other gas appliances are not firing, gas inlet pressure should not exceed  $\frac{1}{2}$  psig.
  - B. While boiler and all other gas appliances are firing, gas inlet pressure must be between minimum and maximum shown on rating label.
19. Check gas outlet (manifold) pressure
  - A. Install manometer on 1/8" outlet pressure tap on gas valve (see Figure 9-3). Use of shutoff valve between manometer and gas valve can prevent pressure surge that blows out manometer fluid.
  - B. Adjust regulator on gas valve so manifold pressure matches values listed on rating label.
  - C. Turning regulator adjustment screw clockwise (↻) increases pressure.
  - D. Turning regulator adjustment screw counterclockwise (↺) decreases pressure.
20. Check gas input rate to boiler
  - A. When checking rate, ensure all other appliances connected to same meter as boiler are off.
  - B. Do not exceed input rate shown on rating label (up to 2,000 ft.)
21. Measure carbon monoxide (CO) level in vent after 5 minutes of main burner operation. CO should not exceed 200 ppm air free.
22. Test thermostat operation while boiler is running. Turn thermostat to lowest setting. Both pilot and main burners should stop firing. Raise thermostat back to highest setting. Pilot and main burners should relight.
23. Verify auto reset LWCO operation while boiler is running. Slowly open drain valve and drain boiler until water level drops below auto reset LWCO line. Water should be visible in gauge glass when auto reset LWCO shuts down both pilot and main burners. Make sure auto reset pressure limit, thermostat or other controls have not shut off boiler. Upon test completion refill boiler to NWL. Pilot and main burners should relight.
24. Check auto reset pressure limit operation. When steam pressure is registered on pressure gauge, lower auto reset pressure limit setting (**MAIN**) below gauge reading. Both pilot and main burners should stop firing. Raise operating auto reset pressure limit setting (**MAIN**) above gauge reading. Pilot and main burners should relight. Return to settings prescribed in step 6 of this section.
25. After boiler has operated for approximately 30 minutes, check boiler and heating system piping for leaks. Repair leaks at once.
26. Inspect vent system for flue gas leaks. Repair leaks found before leaving boiler in operation.
27. Replacement of a steam boiler tends to break loose accumulated scale from system. After new boiler has been installed and put into continuous operation for several days, clean boiler of oil, grease, sludge, and other contaminants that may have been present in existing piping. This will prevent unsteady water line and water carry over into supply main. Skim boiler per Appendix A.

## 10 System Start-Up and Checkout *(continued)*



**Figure 10-6: Combination Gas Valve Detail**

## 10 System Start-Up and Checkout *(continued)*

### CSD-1 Configuration (49-450S - 49-550S CSD-1)

1. Follow steps 1 through 24 in Standard Configuration section.
2. Check manual reset pressure limit. When steam pressure is registered on pressure gauge, lower manual reset pressure limit setting below gauge pressure. Both pilot and main burners should stop firing. Raise manual reset pressure setting to 5 psi. Both pilot and main burners should remain off. Press PUSH FOR RESET button on manual reset pressure limit. Pilot and main burner should relight.
3. Check manual reset LWCO. Press TEST button on control. Both pilot and main burners should stop firing. Press RESET button on control. Pilot and main burner should relight.
4. Check combination gas valve shutdown test. See Figures 9-5 and 9-6.
  - A. Remove **SPARK** wire from ignition module. Both pilot and main burners should stop firing.
  - B. Ignition module will attempt to relight boiler after 5 minutes.
  - C. Replace **SPARK** wire after second attempt.
  - D. Both pilot and main burners should not relight.
  - E. Press RESET button on "Daughter Board". See Figures 9-5 and 14-3.
  - F. Pilot and main burners should relight.

### Combination Gas Valve Leak Test

Boilers over 400 MBH must have a means to leak check each valve seat independently per ANSI Z21.13.

1. Determine total internal gas line volume from shutoff valve to combination gas valve(s). Add 5 cubic inches for each combination gas valve.
2. Determine test time per Figure 10-7.
3. Turn off gas to boiler.
4. Install pressure tap on combination gas valve inlet. See Figure 10-6.
5. Attach manometer to pressure tap.
6. Turn gas back on. Run boiler until gas line is purged of air.
7. Stop boiler and close gas shutoff valve and pilot shutoff valve.
8. Unplug wiring harness from combination gas valve.
9. Apply 24 VAC to MV and MV/PV.
10. Record pressure and start test time.
11. After required time has elapsed, record pressure.
12. Combination gas valve passes when pressure differential is less than 2 in. wc (0.07 psi).
13. Replace combination gas valve when pressure differential is greater than 2 in. wc (0.07 psi).
14. Remove 24 VAC from MV and MV/PV.
15. Apply 24 VAC to PV and MV/PV.
16. Repeat steps 10 through 13.
17. Return boiler back to operating configuration.

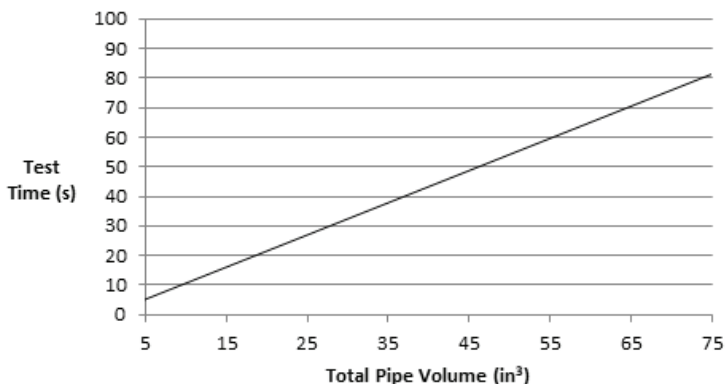


Figure 10-7: Valve Seat Leakage Test Time

#### **WARNING**

Do not leave boiler unattended with 24 VAC applied to combination gas valve MV terminal. Ensure all wiring is restored to figures in Section 9 Electrical before leaving job site. Failure to comply could result in severe personal injury, death, or substantial property damage.

# 11 Operation

## Ignition Sequence of Operation

1. 24 volts is immediately applied to auto reset LWCO when boiler is energized. Vent damper will close as long as auto reset LWCO is satisfied, no call for heat is present and damper switch is in "automatic position".
2. Assuming water is above auto reset LWCO cut-off level, power will appear at terminal P2 of auto reset LWCO.
3. Assuming steam pressure is below auto reset pressure limit setting, power will appear on one side of relay contact 1R1. Relay 1R is mounted on the control panel.
4. A call for heat from thermostat energizes relay coil 1R causing contacts 1R1 to make. Vent damper opens.
5. Once vent damper is fully open, an end switch inside damper will make.
6. Current passes from vent damper through BVS and FRS. Under normal conditions, both of these switches are made and voltage will be supplied to ignition module.
7. Ignition module will start an ignition spark at pilot and apply 24 volts across PV and MV/PV terminals.
8. Pilot flame provides a DC current to ignition module. Current must be greater than 1.0  $\mu$ A (micro amp) for ignition module to keep pilot and main valve open.
9. Once ignition module detects presence of a pilot flame, voltage is applied across MV and MV/PV terminals opening valve and establishing main burner flame.

## Control Operation

LWCO – Interrupts burner operation when water in boiler drops below cut-off level. Power is restored once water in boiler is above cut-off level.

Pressure Limit – Interrupts burner operation when pressure in boiler is greater than MAIN plus DIFF pressures. Both MAIN and DIFF pressures can be adjusted by using screws on top of control.

BVS (Blocked Vent Switch) - Automatically interrupts burner operation in the event flue gas spills from draft diverter opening. This switch is equipped with a reset button which must be pressed to restore normal burner operation.

### **WARNING**

An open blocked vent switch is indicative of a problem with the vent system. If blocked vent switch opens, the cause of the venting problem must be found and corrected by a qualified installer, service agency, or gas supplier before the blocked vent switch is reset.

FRS (Flame Rollout Switch) - Automatically interrupts burner operation when flames or excessive heat are present in vestibule. Flame rollout switch is a single use device which must be replaced by an identical switch in order to restore normal operation.

### **WARNING**

An open flame rollout switch is usually indicative of a plugged heat exchanger. Cause of the flame rollout must be found and corrected by a qualified installer, service agency, or gas supplier, and switch replaced with an identical one, before the boiler is returned to operation.

## 12 Before Leaving Jobsite

Before Leaving Jobsite:

- Boiler filled with water to normal water line
- Performed gas leak test
- Checked pilot burner flame
- Checked main burner flames
- Checked gas input rate
- Checked gas inlet pressure
- Checked gas manifold pressure
- Checked vent damper operation
- Performed combination gas valve shutdown test
- Tested auto reset LWCO
- Tested auto reset pressure limit
- Button on BVS pushed in
- Skimmed boiler
- Secure boiler water sample for quality testing
- Reviewed User's Information Manual and system operation with owner or operator



# 13 Service and Maintenance

## Important Product Safety Information: Refractory Ceramic Fiber Product

### WARNING

Some boiler components use materials that contain refractory ceramic fibers (RCF). RCF has been classified as a possible human carcinogen. When exposed to elevated temperatures, RCF may change into crystalline silica, a known carcinogen. When disturbed as a result of servicing or repair, these substances become airborne and, if inhaled, may be hazardous to your health. Avoid breathing RCF particulates and dust.

#### Precautionary Measures:

- Do not handle RCF parts or attempt any service or repair work involving RCF without wearing the following protective gear:
  1. A properly fitting National Institute for Occupational Safety and Health (NIOSH)-certified air-purifying respirator with a filter efficiency of at least 95%. Respirator should also include a full facepiece when handling used RCF. Other types of respirators may be required depending on site conditions. Current NIOSH recommendations may be found on the NIOSH website <http://www.cdc.gov/niosh/homepage.html>. NIOSH-approved manufacturers, respirators and associated user instructions are listed on the NIOSH website.
  2. Long sleeved, loose fitting clothing that is sufficiently tight around potential entry points for RCF dust.
  3. Gloves.
  4. Eye protection, such as goggles, safety glasses with side shields, or full facepiece.
- Take steps to assure adequate ventilation.
- Handle RCF carefully to minimize airborne dust. Use hand tools whenever possible.
- Dampen used RCF with light water spray prior to removal to prevent airborne dust.
- Do not use compressed air or dry sweeping for clean-up. Frequently clean work area with a vacuum or by wet sweeping to minimize debris accumulation.
- Vacuum work clothes before leaving work area. Wash work clothes separately from other laundry and rinse washing machine after use to avoid contaminating other clothes.
- Wash all exposed body areas gently with soap and water after contact.
- Discard used RCF components by sealing in an airtight plastic bag or container. Refer to local, regional, state or provincial regulations to identify applicable disposal requirements.

#### First Aid Procedures:

- Eye contact: Flush with water for at least 15 minutes. Do not rub eyes. Seek immediate medical attention if irritation persists.
- Skin contact: Wash affected area gently with soap and water. Do not rub or scratch affected skin. Seek immediate medical attention if irritation persists.
- Nose and throat contact: If these become irritated, leave the area and move to a location with clean fresh air. Drink water and blow nose. Seek immediate medical attention if symptoms persist.

# 13 Service and Maintenance *(continued)*

## WARNING

This boiler should be serviced by a qualified installer, service agency or gas supplier. Inspections should be performed at intervals specified in this manual. Maintain manual in a legible condition.

- Keep boiler area clear and free of combustible materials, gasoline and other flammable vapors and liquids.
- Do not place any obstructions in boiler room that will hinder flow of combustion and ventilation air.

## DANGER

**Explosion Hazard. Electrical Shock Hazard. Burn Hazard.** This boiler uses flammable gas, high voltage electricity moving parts, and steam under pressure. Assure that all gas and electric power supplies are turned off. Make sure boiler is not under pressure and temperature is cool before attempting any disassembly for service. Do not rely solely on pressure gauge to make this determination.

## CAUTION

Label all wires prior to disconnection when servicing controls. Wiring errors can cause improper and dangerous operation. Verify proper operation after servicing.

### Annual Inspection

- Vent system
- Boiler flue passages
- Burners
- Steam piping
- Pressure gauge
- Relief valve operation
- Gas piping
- Air openings
- Pilot flame
- Main burner flame
- Gas inlet pressure
- Gas outlet pressure

### Annual Test

- Gas input rate to boiler
- Manual reset LWCO (if equipped)
- Manual pressure limit (if equipped)
- Combination gas valve shutdown test
- Vent damper operation (if equipped)
- Auto reset LWCO
- Auto reset pressure limit
- Thermostat operation
- CO detector operation
- Boiler water quality test

1. Inspection and service should be conducted annually. Turn off electrical power and gas supply while conducting service or maintenance. Follow operating instructions TO TURN OFF GAS TO APPLIANCE. See Figure 10-1.
2. Inspect vent system.
  - A. Remove obstructions in vent pipe and chimney. Inspect masonry chimney liner/ Repair or replace defects and/or deterioration.
  - B. If masonry chimney is lined, verify lining is in good condition and there are no openings into chimney.
  - C. Remove soot accumulations with wire brush and vacuum.
  - D. Repair or replace deteriorated vent pipe and vent accessories.
  - E. Inspect piping to determine that it is adequately supported. Repair sags.
  - F. Repair leaking joints.
3. Inspect boiler flue passages for blockage or soot accumulation.
  - A. Remove vent pipe, vent damper (if equipped), draft hood and BVS.
  - B. Remove top panels.
  - C. Remove canopy.
  - D. Remove baffles.
  - E. Using flashlight, examine all flue passageways.
    - i. If passageways are free of soot and obstruction, replace canopy, secure and seal.
    - ii. If passageways need cleaning, remove burners as described in Paragraph 4. Using long handle wire or bristle flue brush and vacuum, brush flueways thoroughly from top of boiler. Avoid changing combustion chamber insulation with brush.
  - F. Install baffles.
  - G. Install new gasket material (See Section 16: Service Parts). Install canopy.
  - H. Install jacket top panel, draft hood blocked vent switch, vent damper (if equipped), and vent pipe.

## 13 Service and Maintenance *(continued)*

4. Clean Main Burners and Combustion Chamber.
  - A. To remove manifold/burner assembly for cleaning or repairs:
    - i. Remove front door. See Figure 10-2.
    - ii. Disconnect combination gas valve electrical plug.
    - iii. Unplug FRS harness.
    - iv. Disconnect ignitor/sensor wire at ignition module.
    - v. Disconnect pilot ground wire at ignition module.
    - vi. Close gas supply valve and disconnect gas piping from combination gas valve.
    - vii. Remove manifold/burner assembly.
  - B. Brush top of burners with a soft bristle brush. Vacuum burners.
  - C. Check injectors. Gas passageways must be free of lint or dirt.
  - D. Vacuum tip of pilot burner.
  - E. Clean combustion chamber by vacuuming. Exercise care not to damage base insulation.

### WARNING

Be careful handling pilot tubing. Do not crimp or crack pilot tube. Leaking pilot tubing could result in serious injury or substantial property damage.

- F. Reinstall manifold/burner assembly.
  - i. Re-install manifold/burner assembly.
  - ii. Re-install gas piping.
  - iii. Re-connect pilot ground wire at ignition module.
  - iv. Re-connect ignition/sensor wire at ignition module.
  - v. Re-connect FRS harness.
  - vi. Re-connect combination gas valve plug.
  - vii. Replace front door.
5. Inspect Steam Piping
  - A. Check all system piping for leaks.
  - B. Repair any leaks before placing back into service.
6. Inspect Pressure Gauge
  - A. Needle should move with variation in pressure.

- B. Replace gauge if needed.
7. Operate relief valve
  - A. When manually operating relief valve, water and/or steam will discharge. Take precautions to avoid contact with hot water and/or steam, and avoid water damage. Inspect relief valve and lift lever to verify flow.
  - B. If relief valve leaks or will not seat properly, replace relief valve.
8. Inspect Gas Piping
  - A. Sniff around boiler area for indication of gas leak.
  - B. Locate leaks using approved gas detector, a non-corrosive leak detector fluid or other approved leak detection methods.
  - C. Repair any leaks before placing back into service and retest.

### DANGER

#### **Explosion Hazard.**

Do not use matches, candles, open flames or other ignition sources to check for leaks. Failure to comply could result in severe personal injury, death or substantial property damage.

9. Inspect Air Openings
  - A. Keep boiler area clear of combustible materials.
  - B. Remove any obstructions in boiler room that will hinder flow of combustion and ventilation air and dilution air.
10. Follow Section 10 instructions to put boiler back into operation.
11. Check CO detector operation (if available).
12. Lubrication. There are no parts requiring lubrication.
13. If remodeling has occurred, verify combustion air supply is adequate.

# 13 Service and Maintenance *(continued)*

## ⚠ CAUTION

**IF, DURING NORMAL OPERATION, IT IS NECESSARY TO ADD MORE WATER THAN INDICATED BELOW. CONSULT A QUALIFIED INSTALLER OR SERVICE AGENCY TO CHECK YOUR SYSTEM FOR LEAKS.**

Boiler Model Number	Gallons Month	Gallons per Year
49-075S	0.01	0.13
49-100S	0.01	0.13
49-125S	0.01	0.15
49-150S	0.01	0.15
49-175S	0.01	0.17
49-200S	0.01	0.17
49-250S	0.02	0.20
49-299S	0.02	0.21
49-350S	0.02	0.23
49-399S	0.02	0.25
49-450S	0.02	0.27
49-500S	0.02	0.29
49-550S	0.03	0.31

Based on maximum leak rate of 2% steamable water per month

**NOTICE:** When substantial amount of make-up water is used due to lost condensate, or when make-up water is hard or corrosive, water treatment is required. Contact qualified water treatment company for recommended water treatment compounds and procedures.

**Table 13-1: Steam Boiler Water Quality Criteria  
Concentration Limits for Make-up Water and Boiler Water**

Constituent	Make-up Water	Boiler Water
Chlorides	≤ 30 mg/L (ppm)	≤ 100 mg/L (ppm)
Hardness (as a CaCO <sub>3</sub> )	≤ 100 mg/L (ppm)	≤ 200 mg/L (ppm)
pH	7.0 ≤ pH ≤ 11.0	

# 14 How It Works

See Figures 14-1, 14-2 and 14-3

1	Ignition Module	When vent damper is opened completely, control module opens pilot valve and activates ignition spark.
		Control module will sense pilot flame. Once pilot flame is established, control module opens gas valve and main burners will ignite.
		When thermostat is satisfied, ignition module turns off gas valve, and pilot.
2	Transformer	Control transformer reduces line voltage to 24 volts for ignition circuit.
3	Draft Hood	Provides adequate dilution air and ensures proper draft for boiler operation. Must be installed without modification and in accordance with manual instructions.
4	Blocked Vent Switch (BVS)	If vent becomes blocked, switch will open (requiring manual reset) and cause burners to shut down.
5	Auto Reset LWCO	Protects against potentially damaging low water conditions in boiler. In event of low water condition, control will shutdown burners. Auto reset function allows burners to fire when water level is returned to normal.
6	Flame Rollout Switch (FRS)	If flames roll out of burner tubes, switch will open (requiring replacement) and cause burners to shut down. If switch trips, determine cause of flame roll-out.
7	Gas Valve	Regulates gas flow to boiler.
8	Pilot	Provides ignition source for lighting of burners.
9	Vent Damper (if equipped)	Closes during off cycles to reduce heat loss from house to vent.
10	Auto Reset Pressure Limit	Control will shut down burners when boiler pressure exceeds <b>MAIN</b> . Auto reset function allows burners to fire when pressure falls below <b>MAIN</b> minus <b>DIFF</b> .
11	Relay	Energizes boiler when thermostat calls for heat
12	Manual Reset Pressure Limit	Control will shutdown burners when boiler pressure exceeds <b>MAIN</b> setting. Manual reset function requires physically resetting the control.
13	Manual Reset LWCO	Control protects against potentially damaging low water conditions in boiler. In event of low water condition, control will shutdown burners. Manual reset function requires physically resetting control.
14	Daughter Board	Control will shutdown burners when a loss of pilot flame is detected. Manual reset function requires physically resetting control.

# 14 How It Works *(continued)*

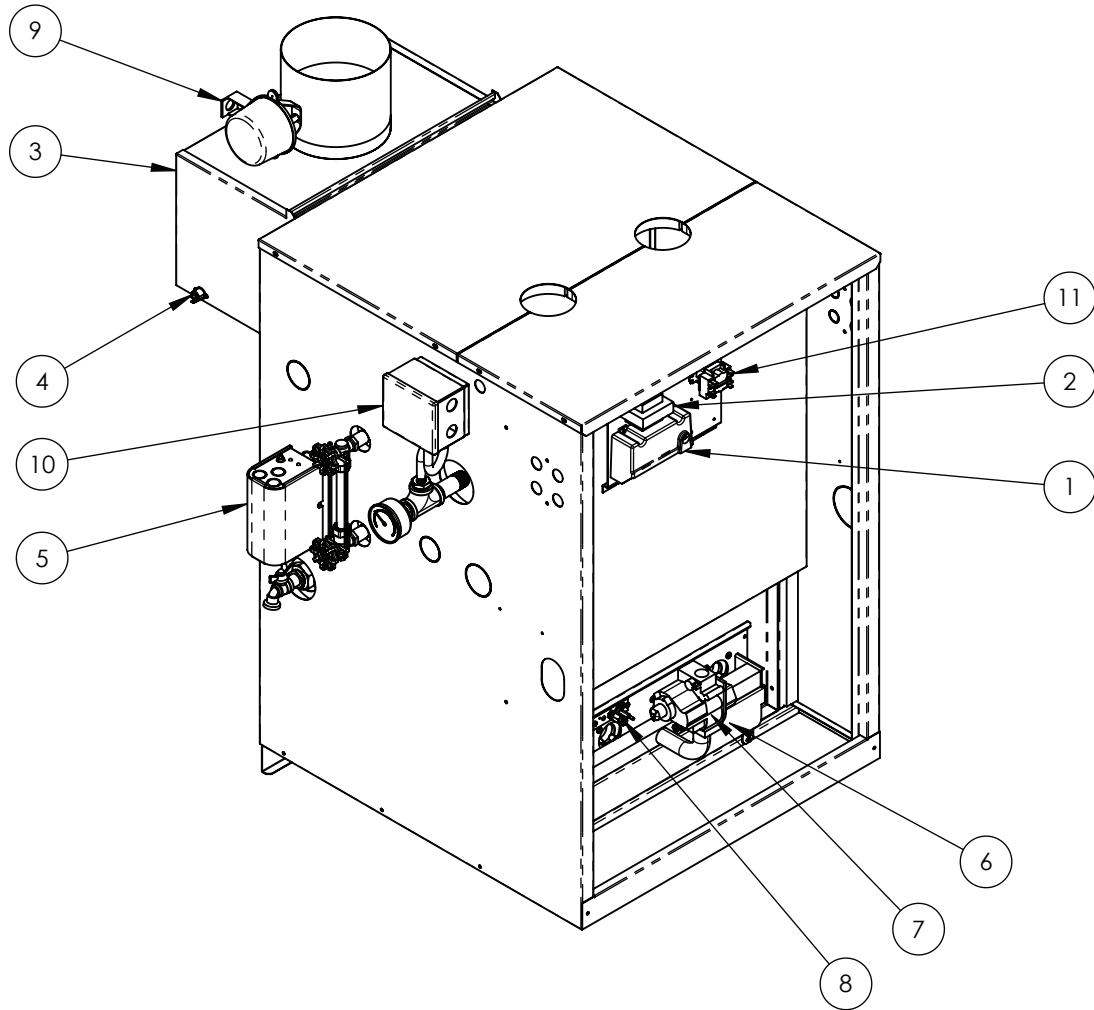
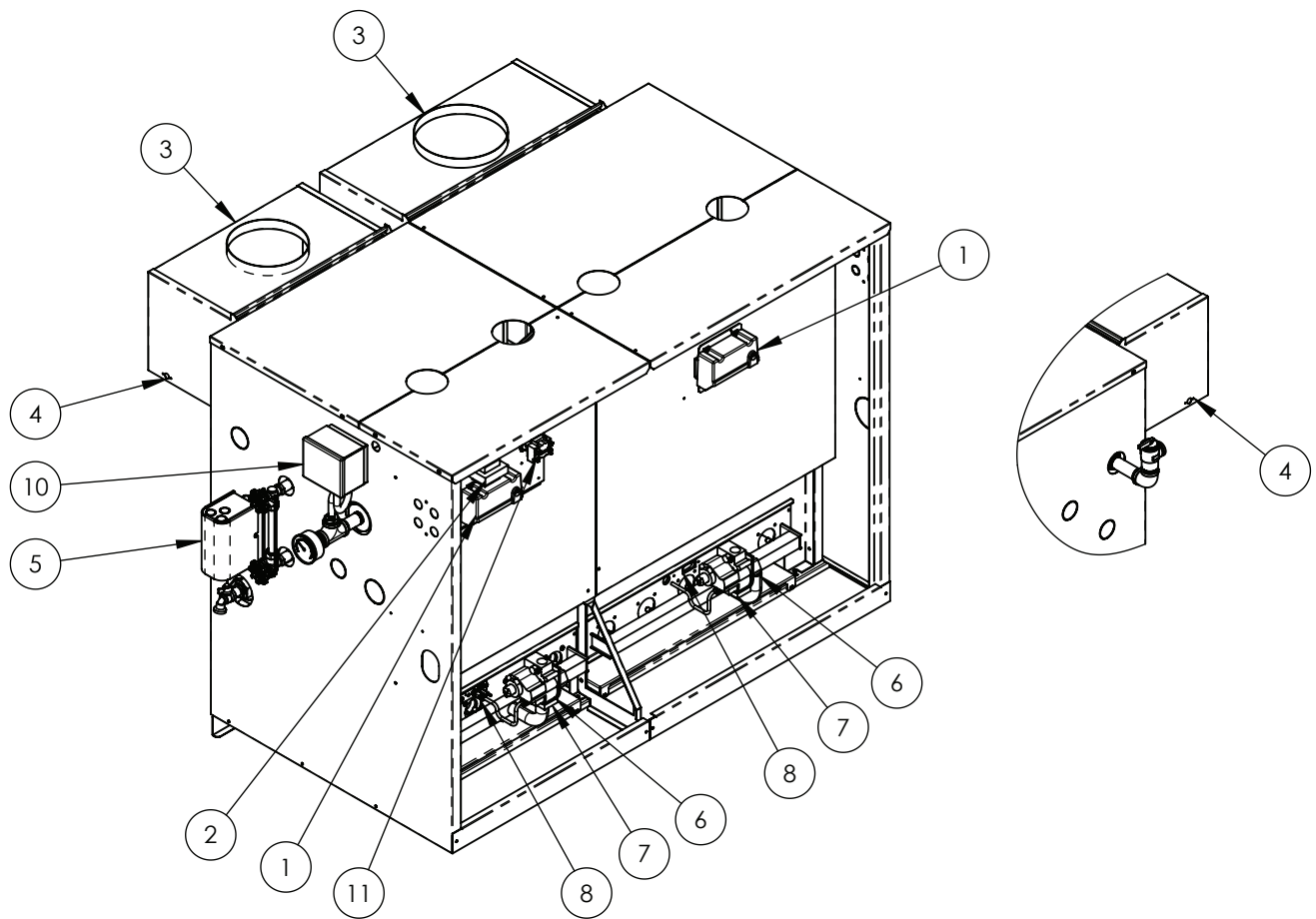


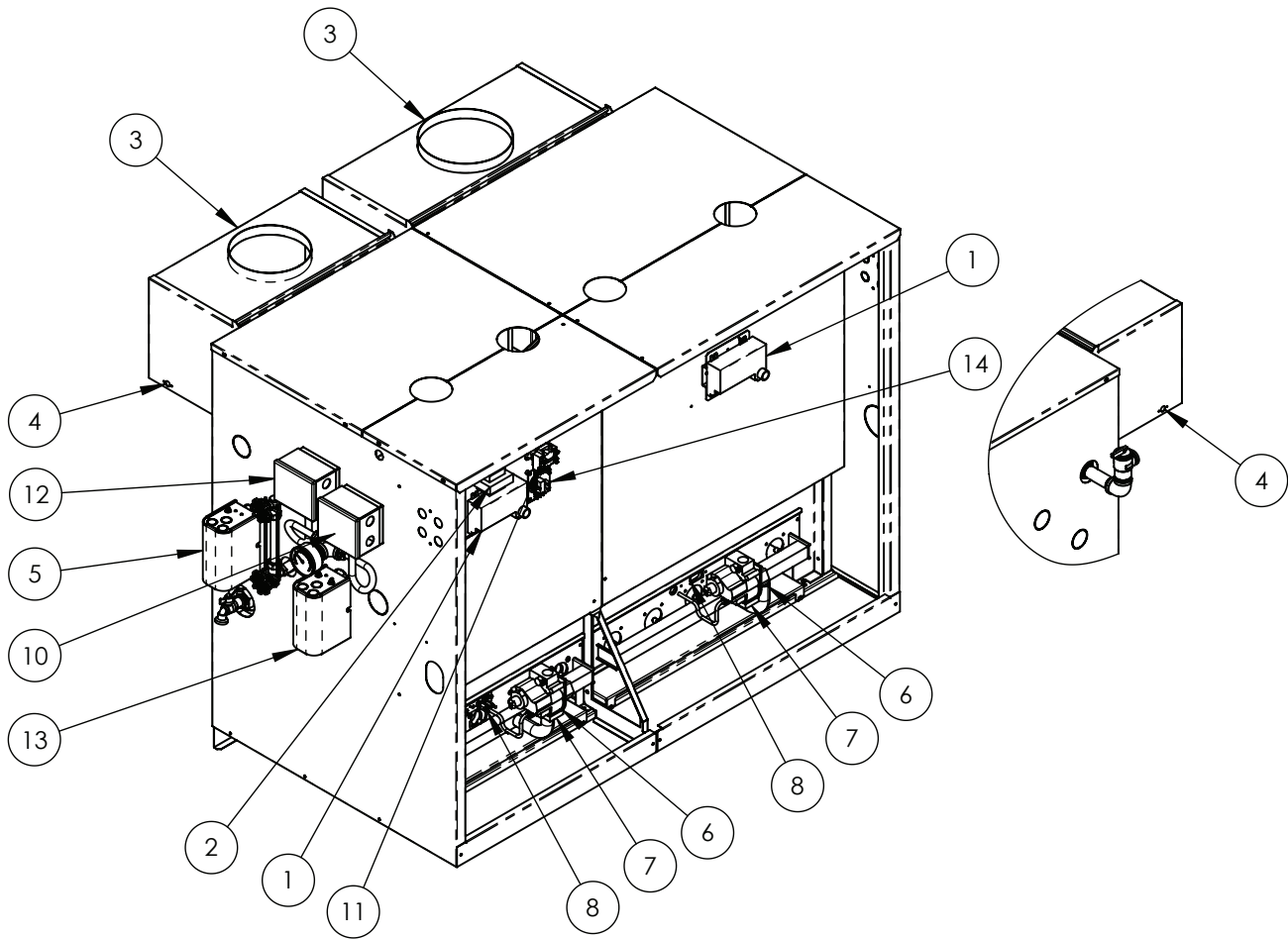
Figure 14-1: Controls Location 49-075S through 49-299S

# 14 How It Works *(continued)*



**Figure 14-2: Controls Location 49-350S through 49-550S, Non CSD-1**

# 14 How It Works *(continued)*



**Figure 14-3: Controls Location 49-450S through 49-550S, CSD-1**



# 15 Troubleshooting

1. Troubleshooting should be completed by a qualified installer, service agency or gas supplier.
2. Before seeking technical assistance, the qualified installer, service agency or gas supplier should have an electrical meter and gas pressure gauge available for use.
3. Check electrical connections on boiler before proceeding. See Figures 9-1, 9-3 or 9-5.
  - A. Ensure 120VAC power polarity is correct, and boiler is properly grounded.
  - B. Ensure control power supply 24VAC (minimum 18VAC - maximum 30VAC) polarity is correct.
4. Do not insert meter probes into wiring harness pins. Doing so may damage pin, resulting in loose connection when harness is reconnected.
5. Refer to Figures 15-1, 15-2 or 15-3 for Troubleshooting Flow Diagrams.

# 15 Troubleshooting *(continued)*

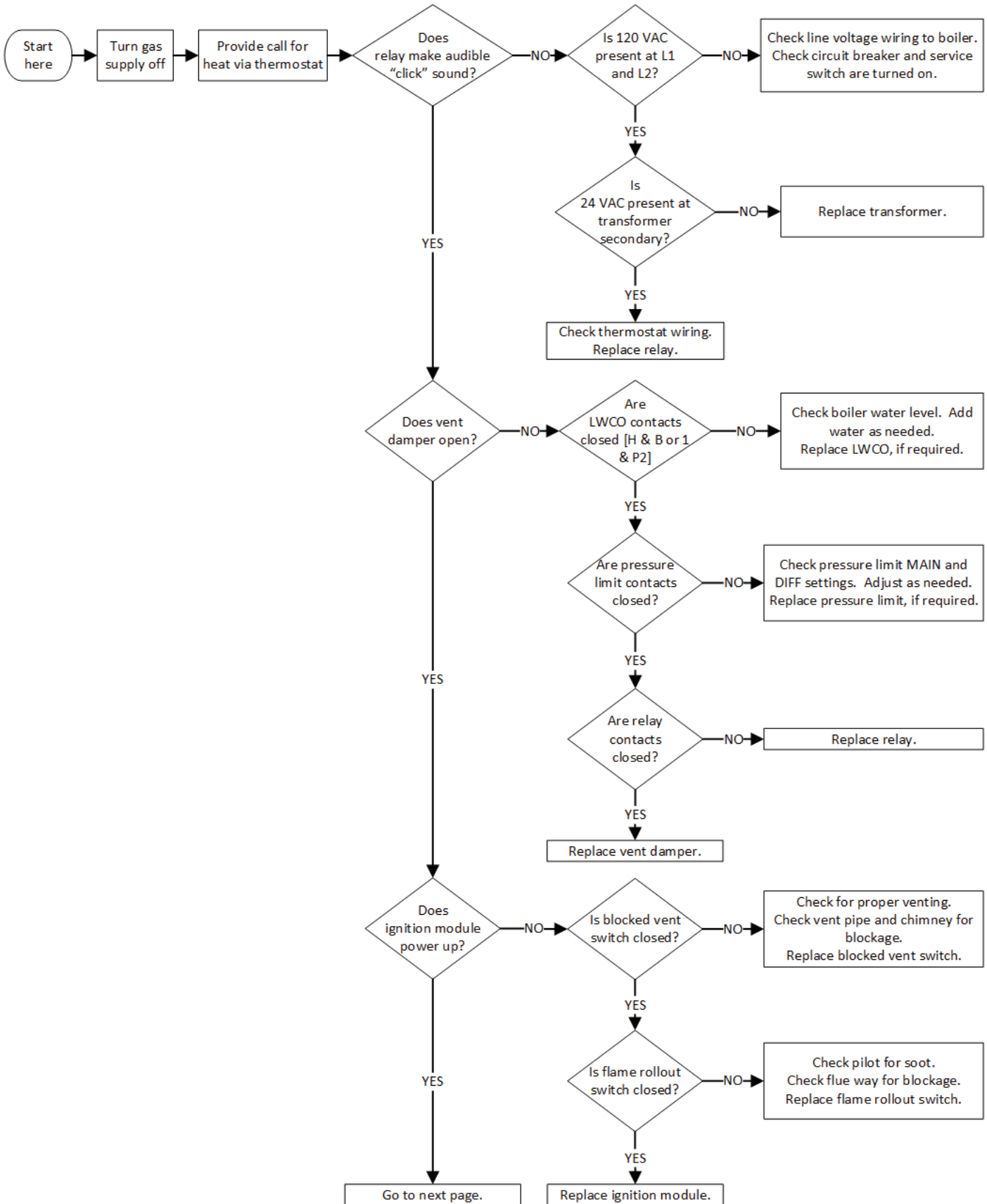


Figure 15-1: Troubleshooting Flow Diagram 49-075S through 49-299S

# 15 Troubleshooting *(continued)*

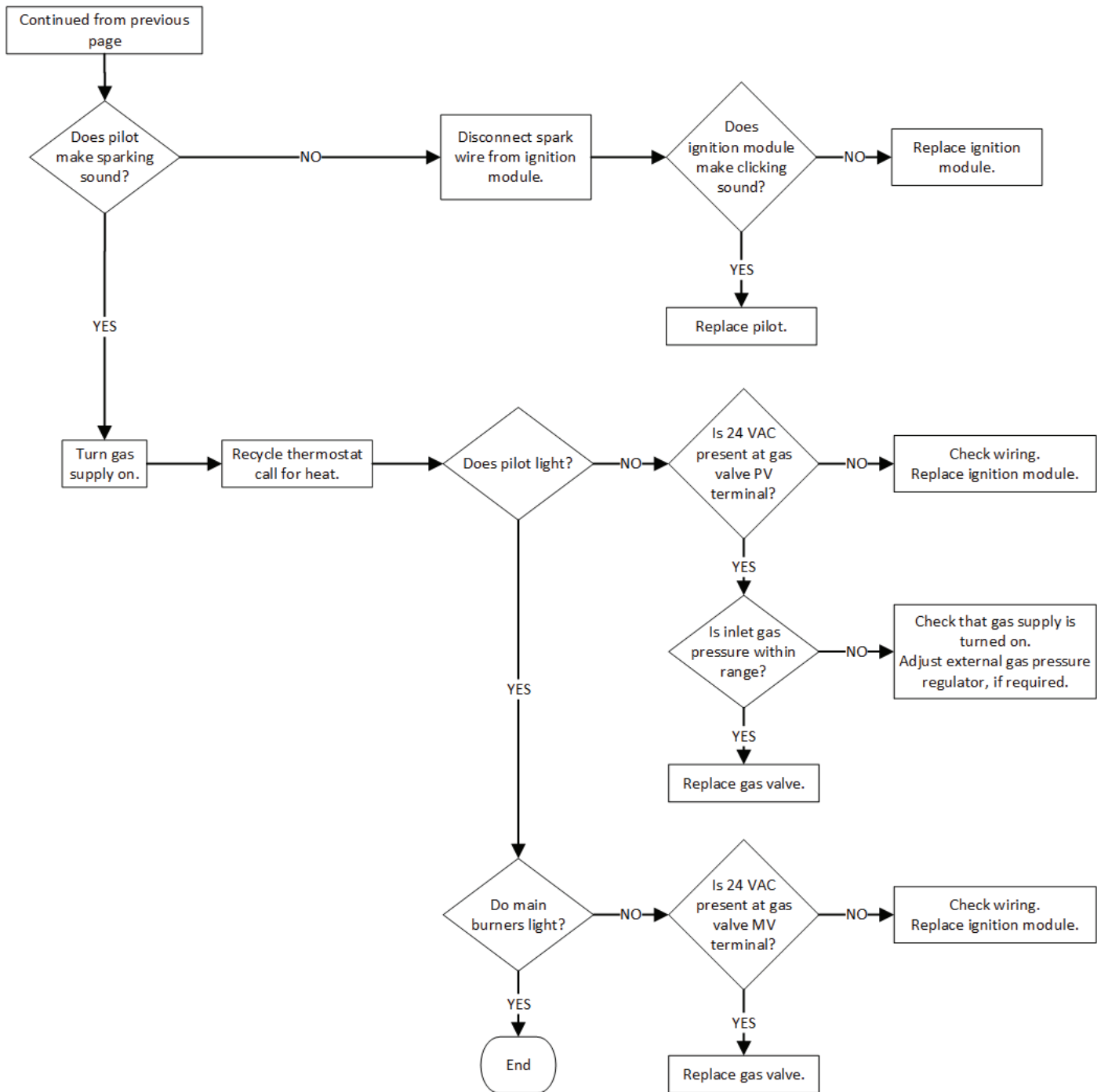


Figure 15-1: Troubleshooting Flow Diagram 49-075S through 49-299S  
(continued from previous page)

# 15 Troubleshooting *(continued)*

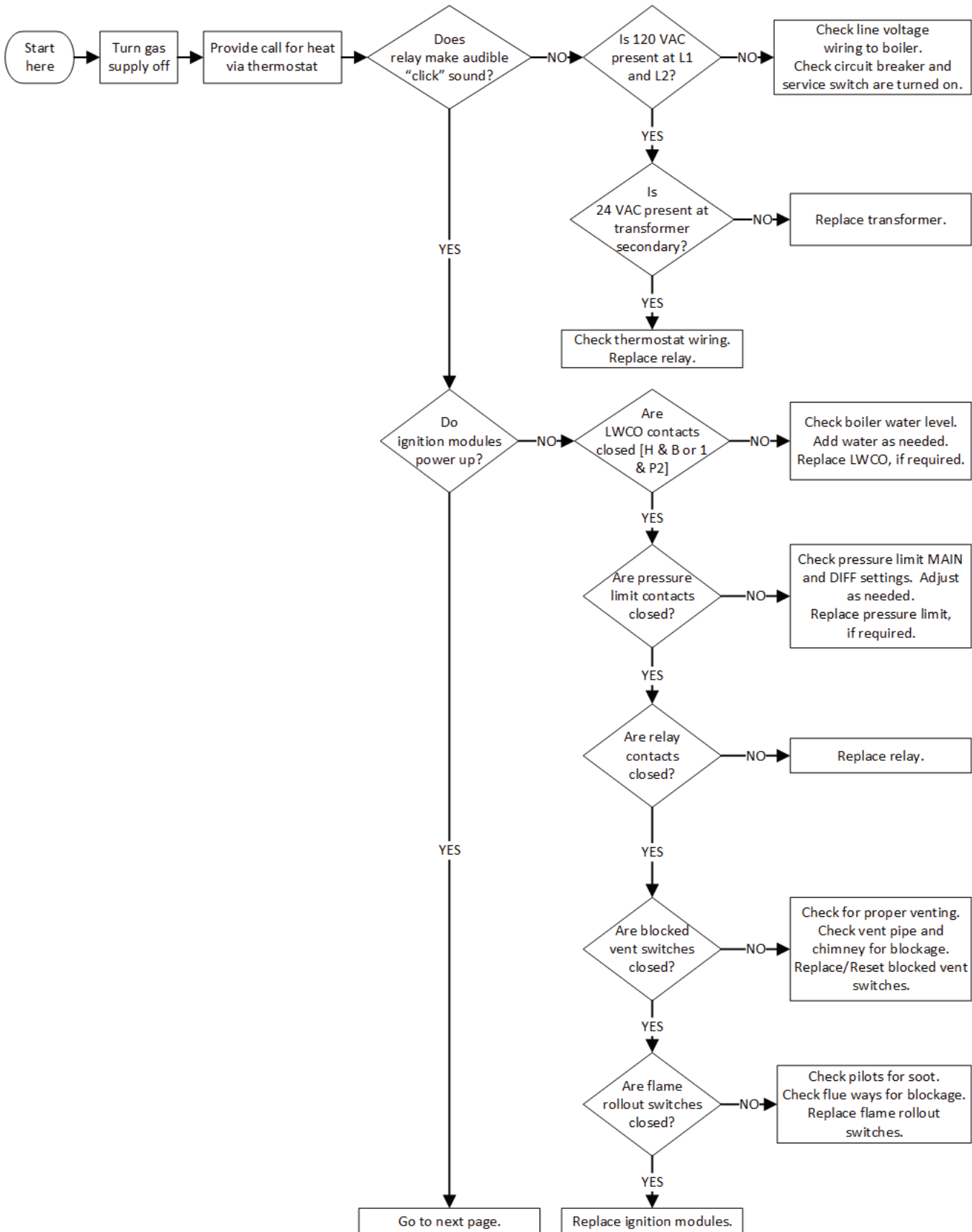


Figure 15-2: Troubleshooting Flow Diagram 49-350S through 49-550S, Non CSD-1

# 15 Troubleshooting *(continued)*

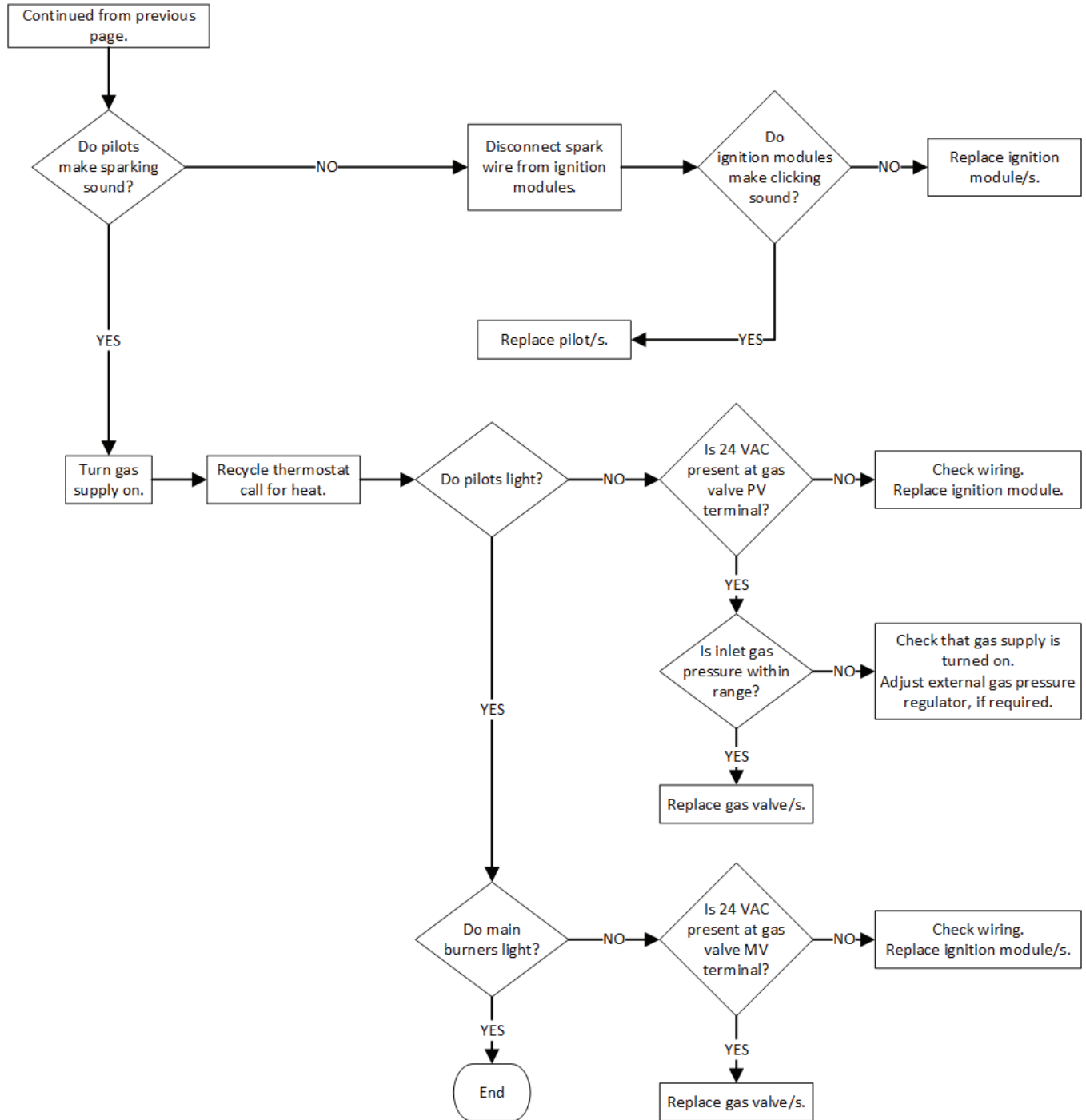


Figure 15-2: Troubleshooting Flow Diagram 49-350S through 49-550S, Non CSD-1  
(continued from previous page)

# 15 Troubleshooting *(continued)*

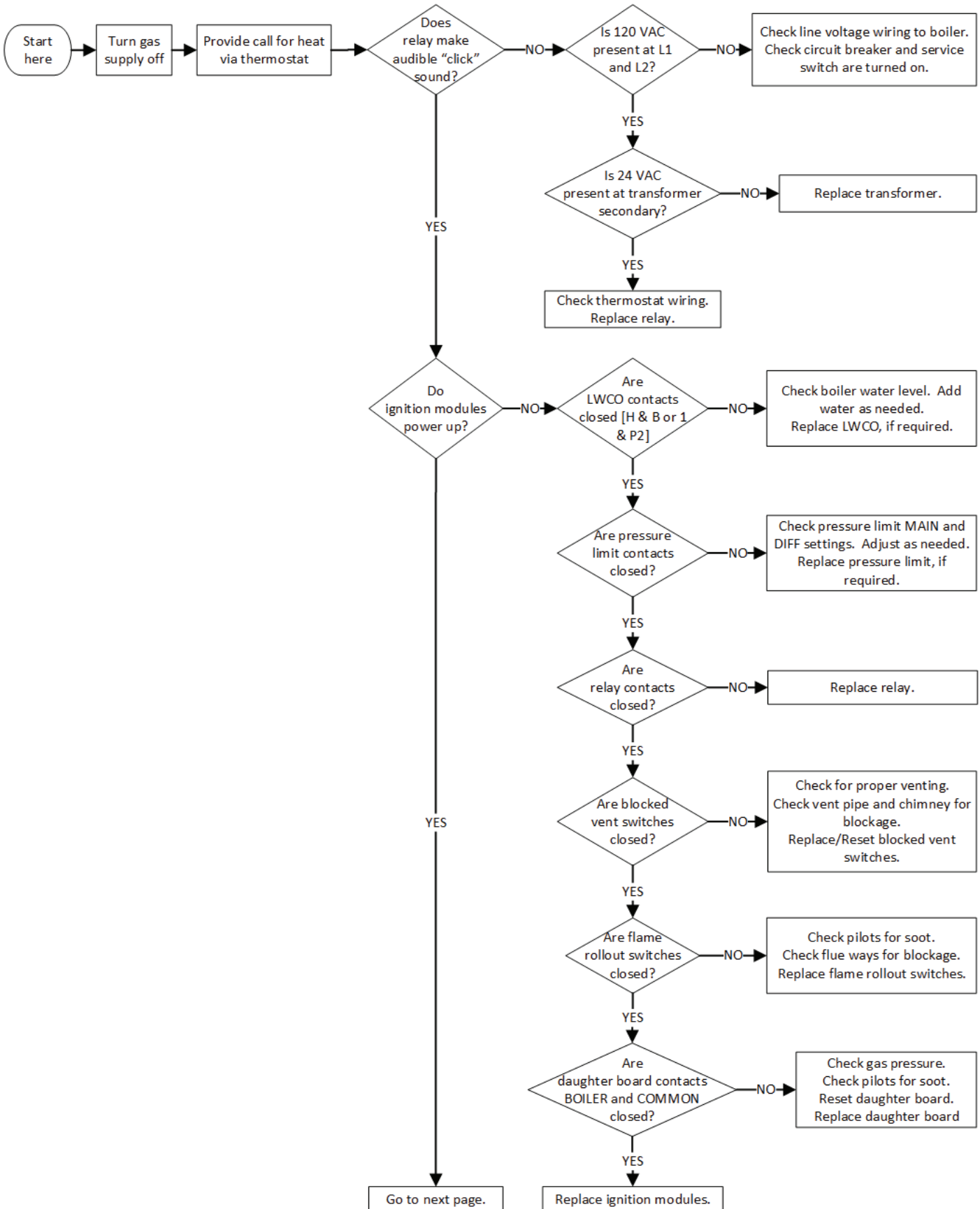


Figure 15-3: Troubleshooting Flow Diagram 49-450S through 49-550S, CSD-1

# 15 Troubleshooting *(continued)*

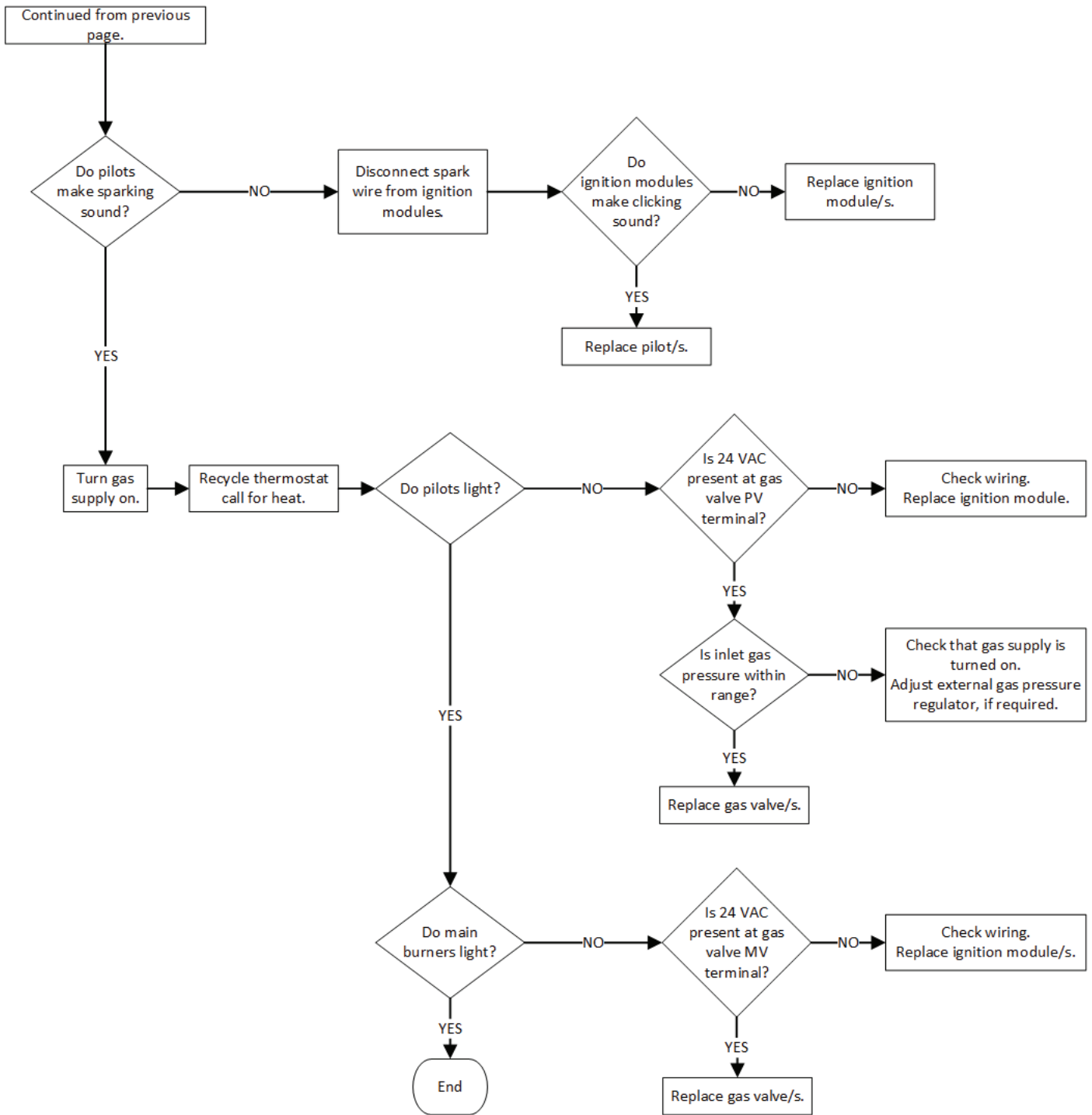


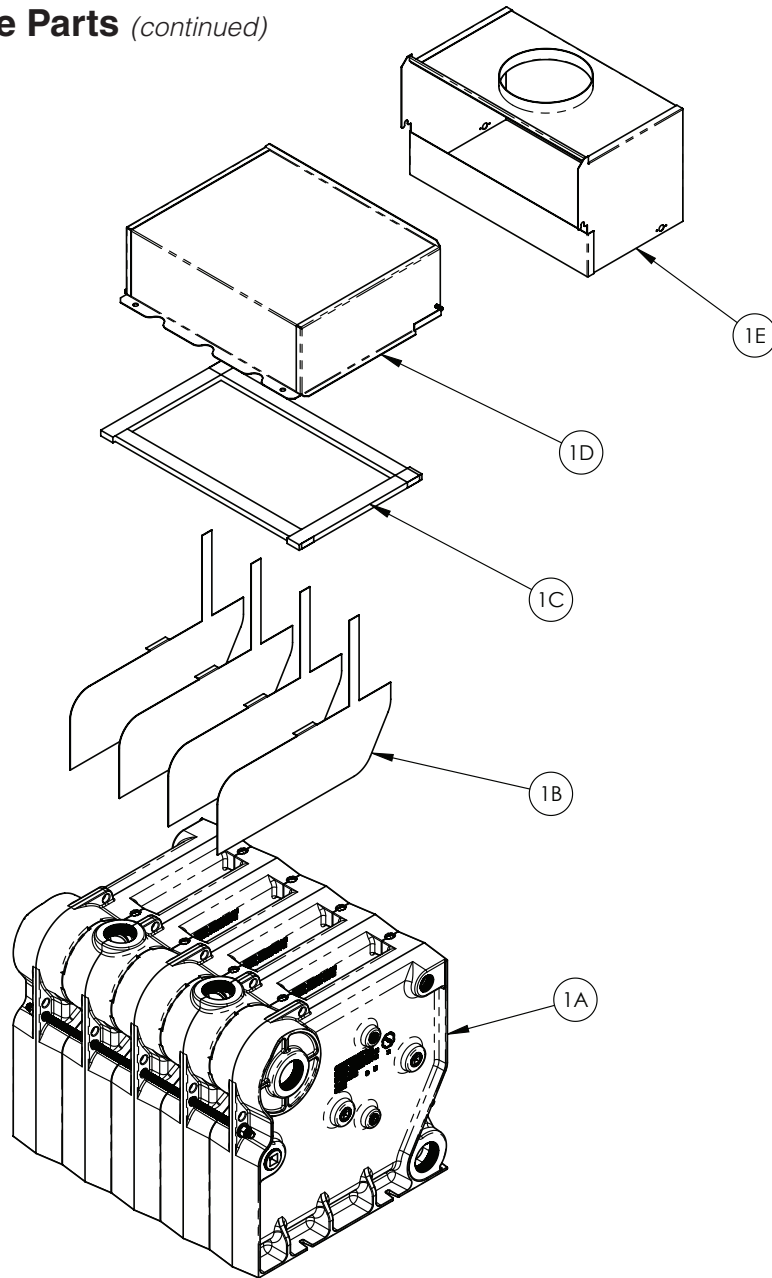
Figure 15-3: Troubleshooting Flow Diagram 49-450S through 49-550S, CSD-1 (continued from previous page)

## 16 Service Parts

All service parts may be obtained through your local Velocity Boiler Works wholesale distributor. Should you require assistance in locating a Velocity Boiler Works distributor in your area, or you have questions regarding the availability of products or service parts, please contact us at (215) 535-8900 or Fax (215) 535-9736 or at [www.velocityboilerworks.com](http://www.velocityboilerworks.com)

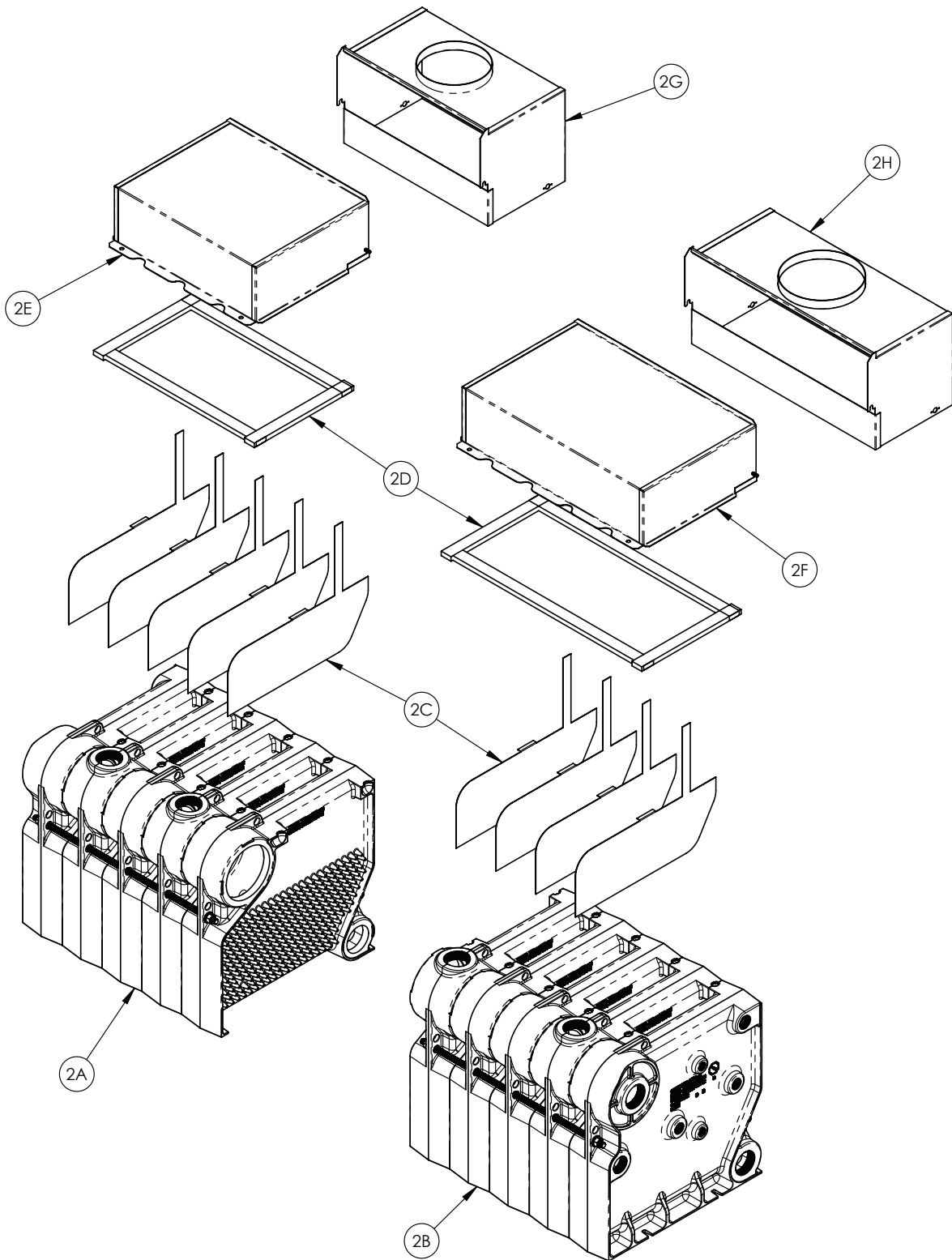


# 16 Service Parts *(continued)*



Key No.	Description	Part Number [Quantity]							
		49-075S	49-100S	49-125S	49-150S	49-175S	49-200S	49-250S	49-299S
1A	Section Assembly (includes both canopy and base gaskets)	111268-03 [1]	111268-03 [1]	111268-04 [1]	111268-04 [1]	111268-05 [1]	111268-05 [1]	111268-06 [1]	111268-07 [1]
1B	Baffles (set of 3)	111263-01 [1]				111263-01 [2]			
1C	Canopy Gasket	6206001 [1]							
1D	Canopy	111290-03 [1]	111290-03 [1]	111290-04 [1]	111290-04 [1]	111290-05 [1]	111290-05 [1]	111290-06 [1]	111290-07 [1]
1E	Draft Hood	110900-03 [1]	110900-03 [1]	110900-04 [1]	110900-04 [1]	110900-05 [1]	110900-05 [1]	110900-06 [1]	110900-07 [1]

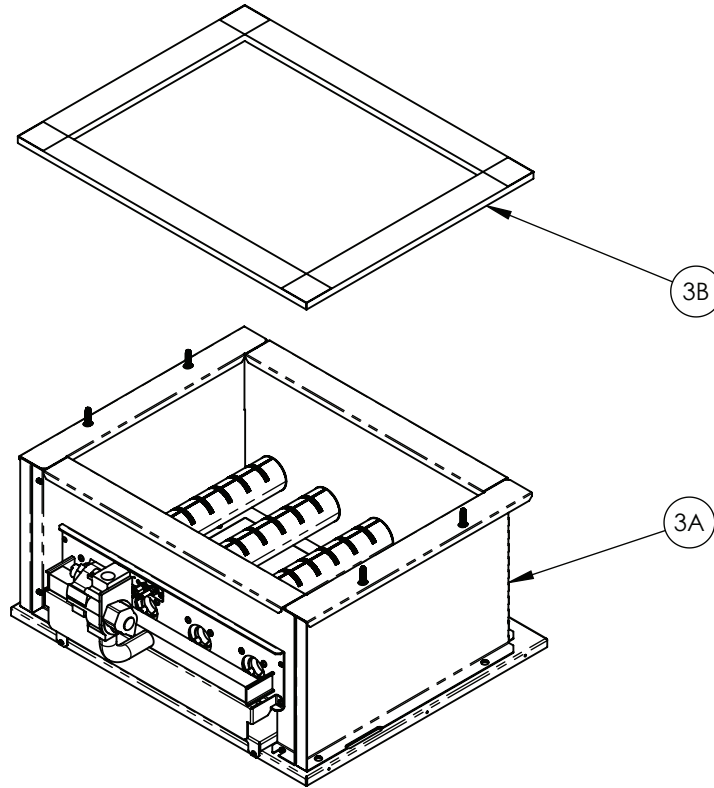
# 16 Service Parts *(continued)*



# 16 Service Parts *(continued)*

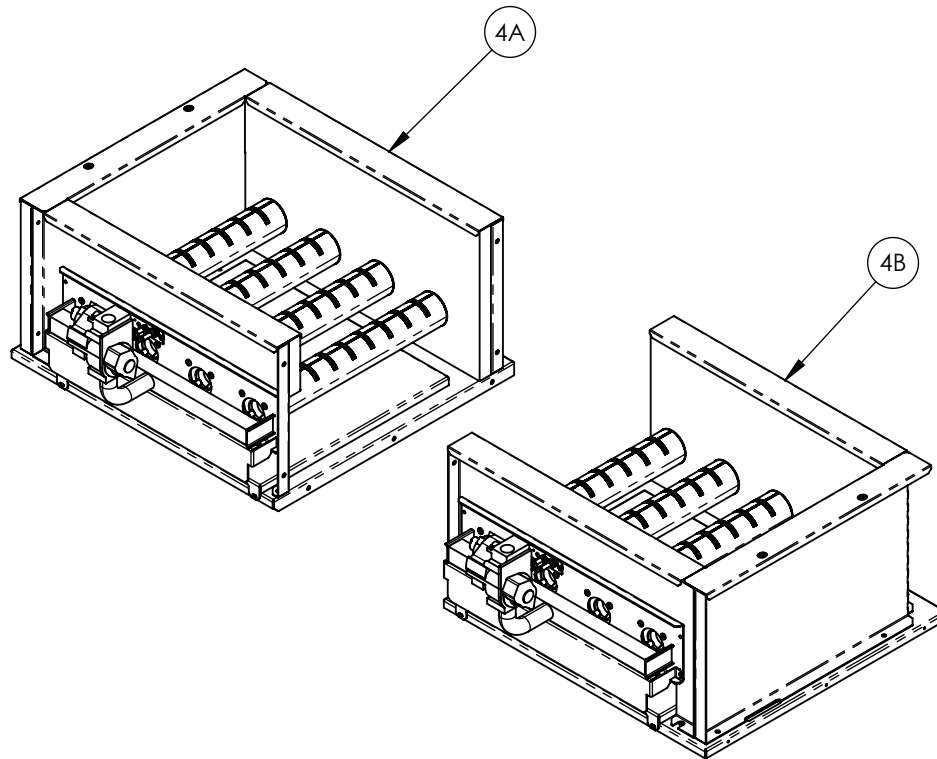
Key No.	Description	Part Number [Quantity]				
		49-350S	49-399S	49-450S	49-500S	49-550S
2A	Left Half Section Assembly	111285-04 [1]	111285-04 [1]	111285-05 [1]	111285-06 [1]	111285-06 [1]
2B	Right Half Section Assembly	111287-04 [1]	111287-05 [1]	111287-05 [1]	111287-05 [1]	111287-06 [1]
2C	Baffles (set of 3)	111263-01 [3]			111263-01 [4]	
2D	Canopy Gasket	6206001 [2]				
2E	Left Side Canopy	111290-04 [1]	111290-04 [1]	111290-05 [1]	111290-06 [1]	111290-06 [1]
2F	Right Side Canopy	111290-05 [1]	111290-06 [1]	111290-06 [1]	111290-06 [1]	111290-07 [1]
2G	Left Side Draft Hood	110900-04 [1]	110900-04 [1]	110900-05 [1]	110900-06 [1]	110900-06 [1]
2H	Right Side Draft Hood	110900-05 [1]	110900-06 [1]	110900-06 [1]	110900-06 [1]	110900-07 [1]
Not Shown	Push Nipple Sealant	Source Locally Thread Sealant with PTFE meeting UL MH8007 (N)				
Not Shown	Section Assembly Flue Joint Sealant	Source Locally High Temperature Silicone RTV Meeting ASTM C920 Type S, Grade NS, Class 25, 500°F Continuous Service				

# 16 Service Parts *(continued)*



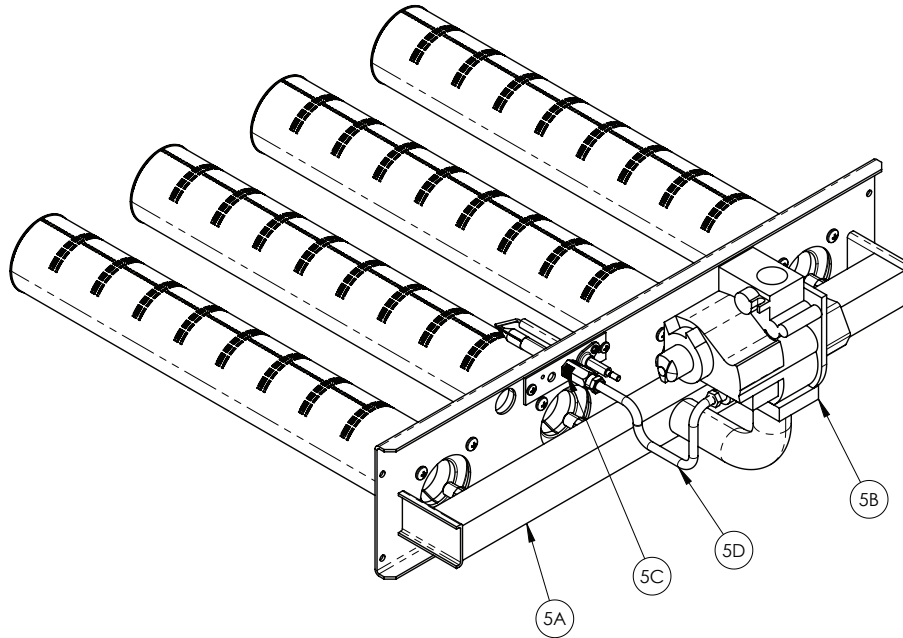
Key No.	Description	Part Number [Quantity]							
		49-075S	49-100S	49-125S	49-150S	49-175S	49-200S	49-250S	49-299S
3A	Complete Base Assembly (Base Gasket included)	Consult Factory	110901-03 [1]	110902-04 [1]	110901-04 [1]	110902-05 [1]	110901-05 [1]	110901-06 [1]	110901-07 [1]
3B	Base Gasket	6206002 [1]							

# 16 Service Parts *(continued)*



Key No.	Description	Part Number [Quantity]				
		49-350S	49-399S	49-450S	49-500S	49-550S
4A	Complete Left Half Base Assembly	110908-04 [1]	110908-04 [1]	111236-05 [1]	111236-06 [1]	111236-06 [1]
4B	Complete Right Half Base Assembly	110909-04 [1]	110909-05 [1]	111237-05 [1]	111237-05 [1]	111237-06 [1]
Not Shown	Section Assembly to Base Sealant	Source Locally High Temperature Silicone RTV Meeting ASTM C920 Type S, Grade NS, Class 25, 500°F Continuous Service				

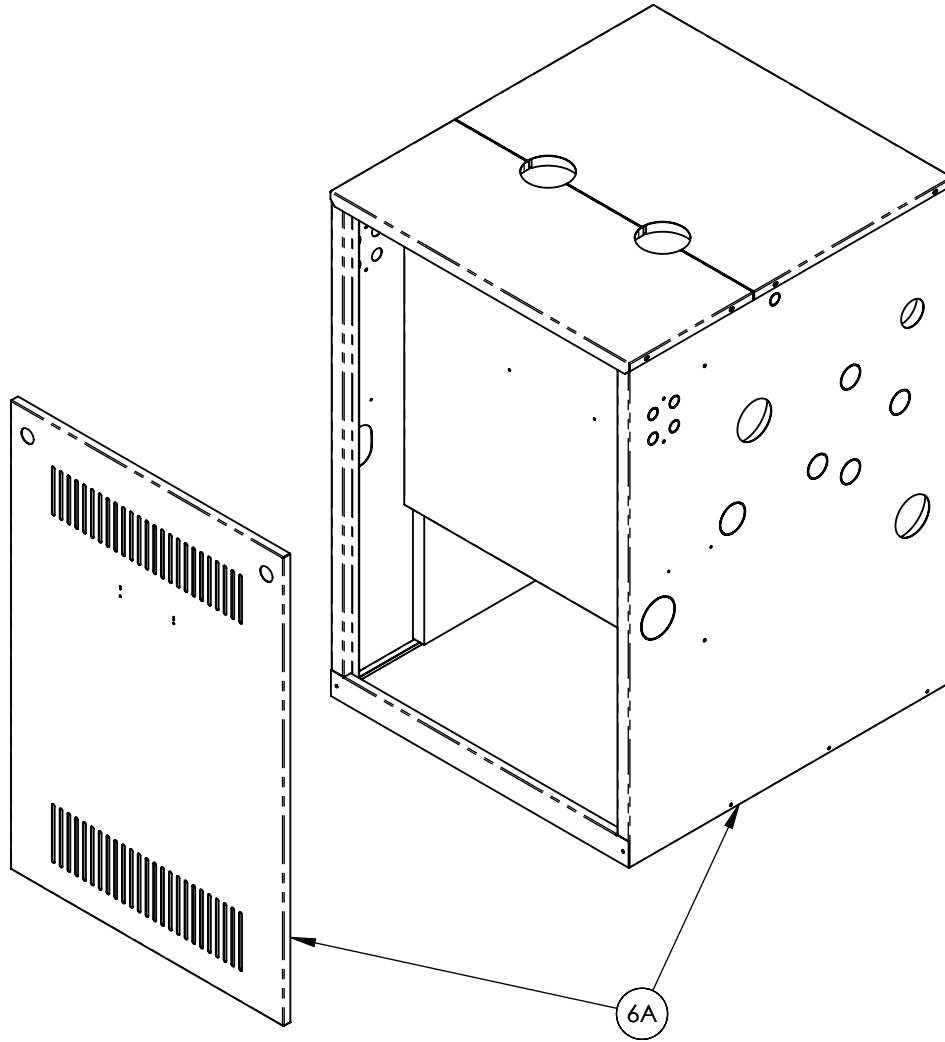
# 16 Service Parts *(continued)*



Key No.	Description	Part Number [Quantity]							
		49-075S	49-100S	49-125S	49-150S	49-175S	49-200S	49-250S	49-299S
5A	Manifold, Burners, Pilot, Insulation Assembly	Consult Factory	111277-03 [1]	111269-04 [1]	111277-04 [1]	111269-05 [1]	111277-05 [1]	111277-06 [1]	111277-07 [1]
5B	Gas Valve	111261-01 [1]				109622-01 [1]			
5C	Pilot	111279-01 [1]							
5D	1/4" Pilot Tubing	109611-01 [1]							

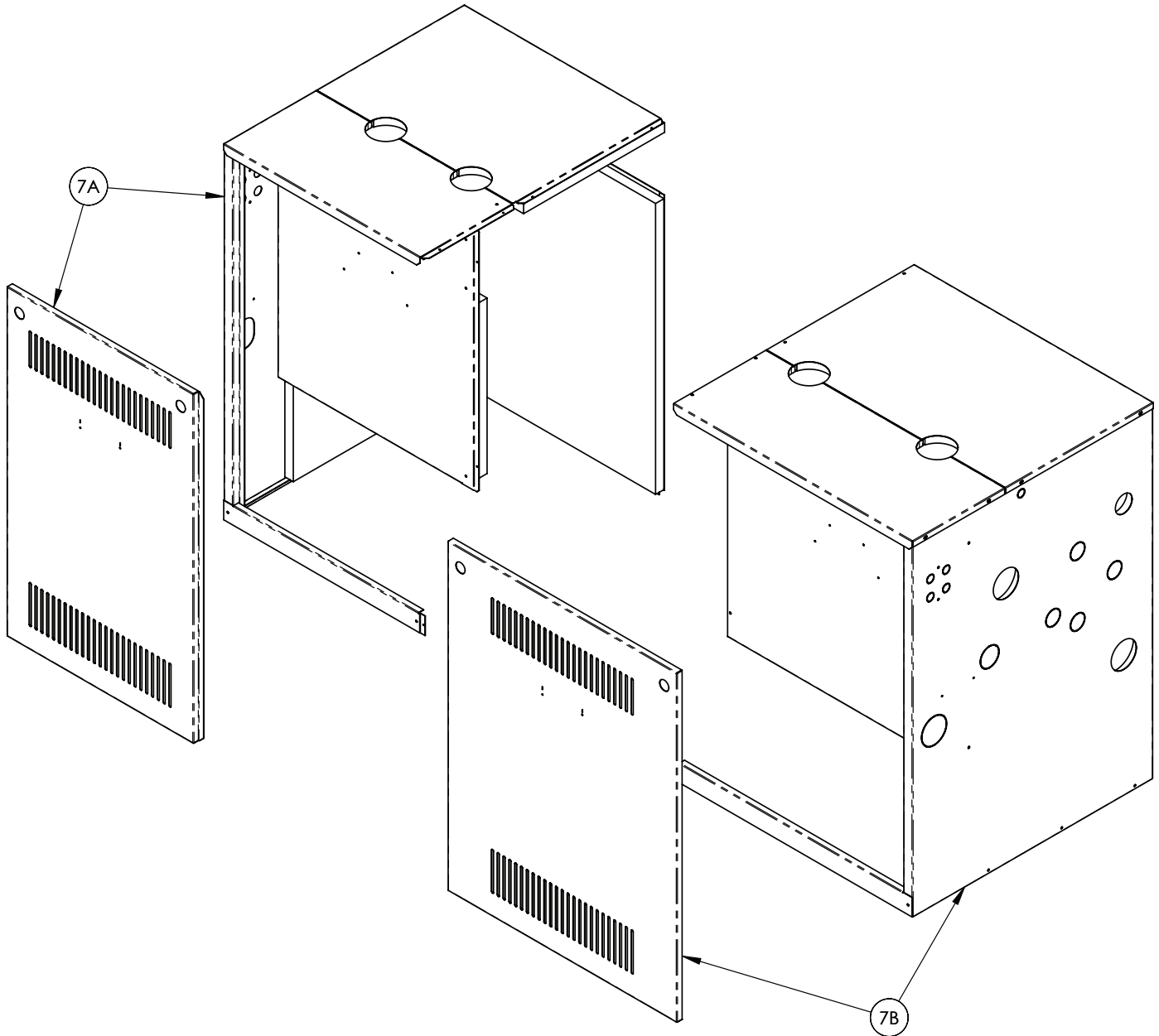
Key No.	Description	Part Number [Quantity]				
		49-350S	49-399S	49-450S	49-500S	49-550S
5A Left	Manifold, Burners, Pilot, Insulation Assembly	111277-04 [1]	111277-04 [1]	111277-05 [1]	111277-06 [1]	111277-06 [1]
5A Right	Manifold, Burners, Pilot, Insulation Assembly	111277-05 [1]	111277-06 [1]	111277-06 [1]	111277-06 [1]	111277-07 [1]
5B Left	Gas Valve	111261-01 [1]	111261-01 [1]	109622-01 [1]	109622-01 [1]	109622-01 [1]
5B Right	Gas Valve	109622-01 [1]				
5C Left	Pilot	111279-01 [1]				
5C Right	Pilot	111279-01 [1]				
5D Left	1/4" Pilot Tubing	109611-01 [1]				
5D Right	1/4" Pilot Tubing	109611-01 [1]				

# 16 Service Parts *(continued)*



Key No.	Description	Part Number [Quantity]							
		49-075S	49-100S	49-125S	49-150S	49-175S	49-200S	49-250S	49-299S
6A	Jacket Set	111365-03 [1]	111365-03 [1]	111365-04 [1]	111365-04 [1]	111365-05 [1]	111365-05 [1]	111365-06 [1]	111365-07 [1]

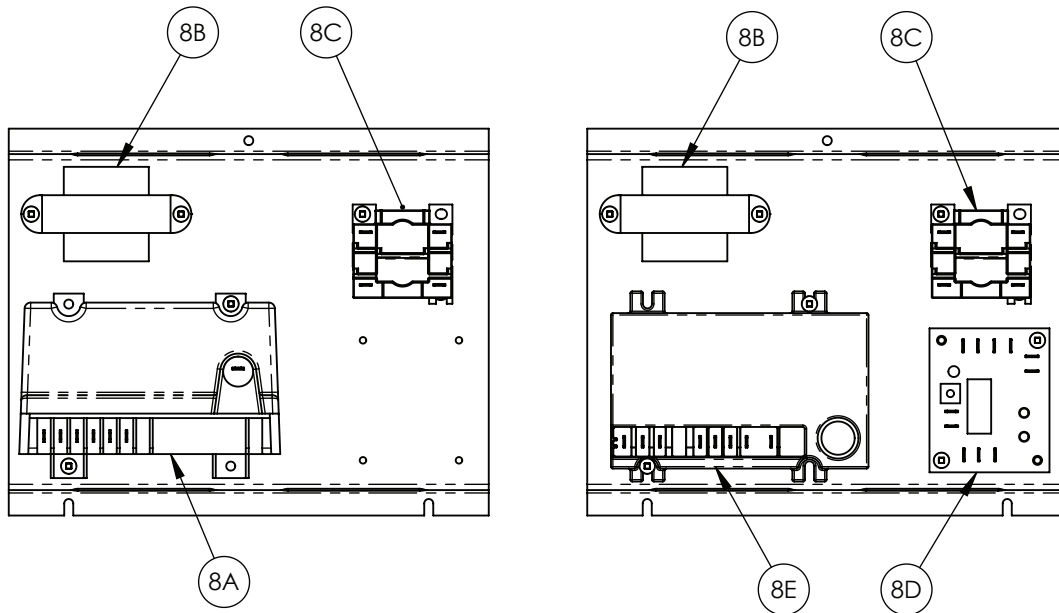
# 16 Service Parts *(continued)*



Key No.	Description	Part Number [Quantity]				
		49-350S	49-399S	49-450S	49-500S	49-550S
7A	Left Side Jacket Set	111370-04 [1]	111370-04 [1]	111370-05 [1]	111370-06 [1]	111370-06 [1]
7B	Right Side Jacket Set	111371-04 [1]	111371-05 [1]	111371-05 [1]	111371-05 [1]	111371-06 [1]



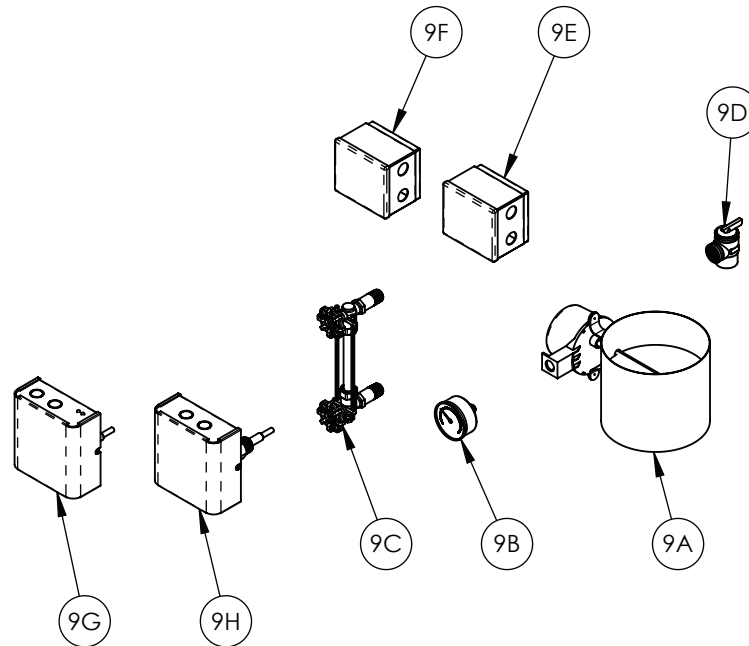
# 16 Service Parts *(continued)*




Key No.	Description	Part Number [Quantity]							
		49-075S	49-100S	49-125S	49-150S	49-175S	49-200S	49-250S	49-299S
8A (Non CSD-1)	Ignition Module, Honeywell	109633-01 [1]							
8B	Transformer	106034-01 [1]							
8C	Relay	111282-01 [1]							

Key No.	Description	Part Number [Quantity]				
		49-350S	49-399S	49-450S	49-500S	49-550S
8A (Non CSD-1)	Ignition Module, Honeywell	109633-01 [2]				
8B	Transformer	106034-01 [1]				
8C	Relay	111282-01 [1]				
8D (CSD-1)	Manual Reset Daughter Board, UTEC	N/A		111288-01 [1]		
8E (CSD-1)	Ignition Module, UTEC	N/A		111289-01 [2]		

# 16 Service Parts *(continued)*

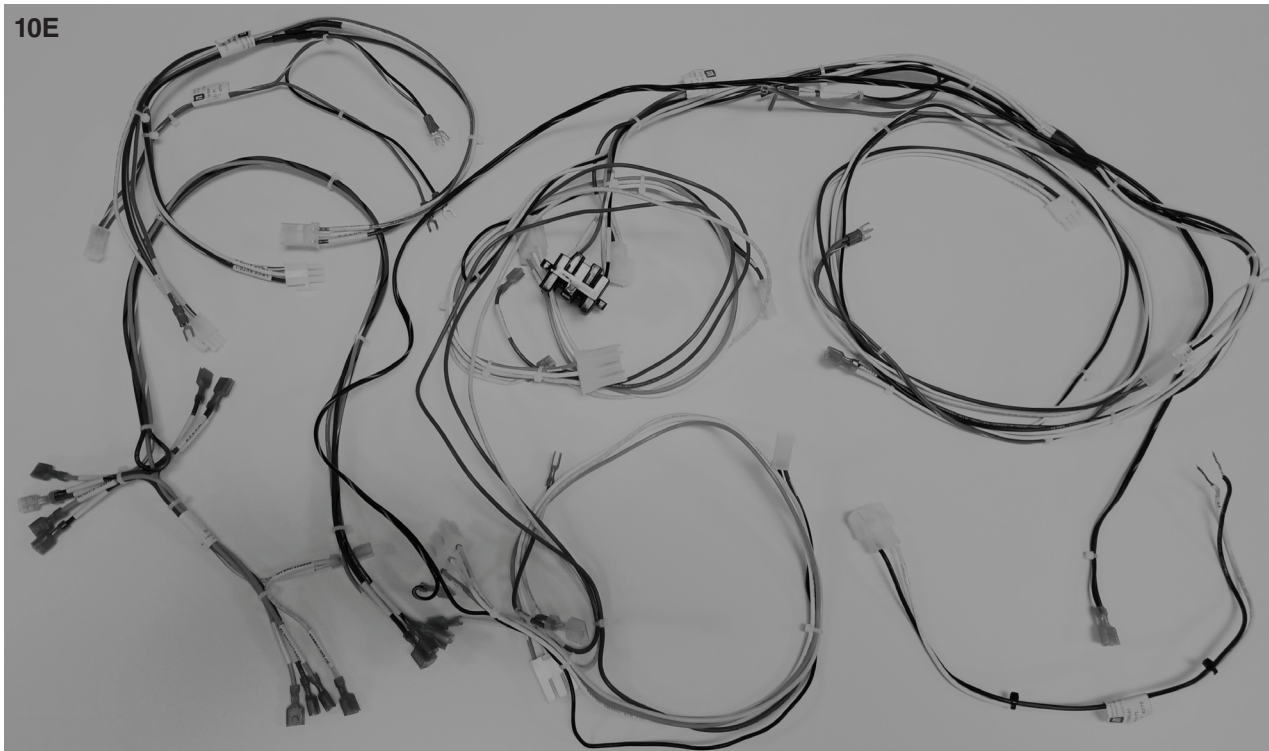
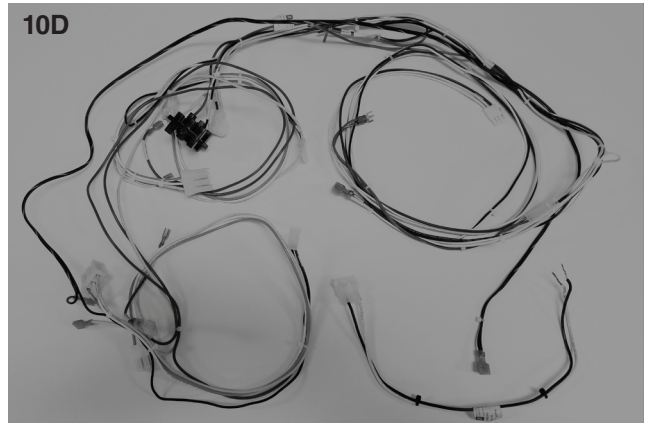
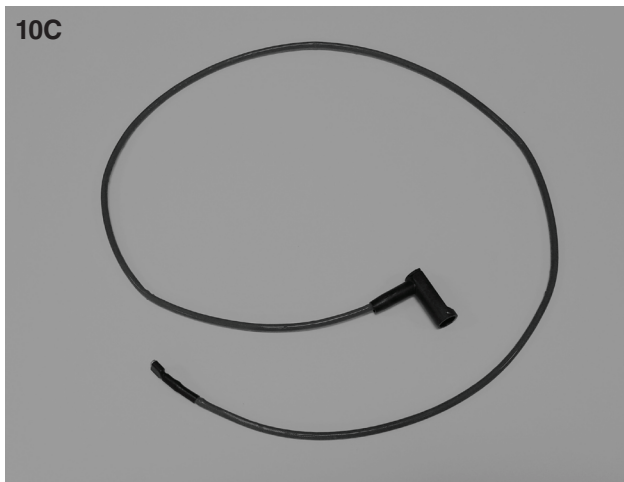
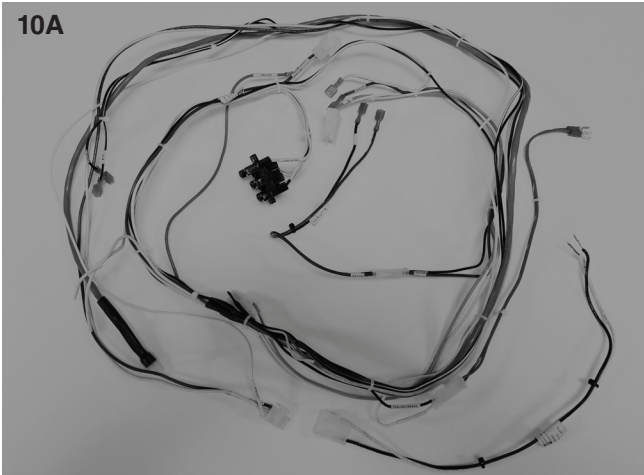


Key No.	Description	Part Number [Quantity]							
		49-075S	49-100S	49-125S	49-150S	49-175S	49-200S	49-250S	49-299S
9A	Vent Damper	109634-02 [1]	109634-02 [1]	109634-03 [1]	109634-03 [1]	109634-04 [1]	109634-04 [1]	109634-05 [1]	109634-05 [1]
9B	Pressure Gauge	109707-01 [1]							
9C	Gauge Glass	111271-01 [1]							
9D	Relief Valve	111267-01 [1]							
9E	Pressure Limit Auto Reset, Honeywell	111280-01 [1]							
9F	Pressure Limit Manual Reset, Honeywell	N/A							
9G	LWCO Auto Reset, Hydrolevel	111272-01 [1]							
9H	LWCO Manual Reset, Hydrolevel	N/A 							
Not Shown	Blocked Vent Switch (BVS)	109742-01 [1]							
Not Shown	Flame Rollout Switch (FRS)	109616-01 [1]							
Not Shown	Knock-Down Draw up Kit	111239-01 [1]							
Not Shown	Slip Nipple Kit	111582-01							

# 16 Service Parts *(continued)*

Key No.	Description	Part Number [Quantity]				
		49-350S	49-399S	49-450S	49-500S	49-550S
9A	Vent Damper	N/A				
9B	Pressure Gauge	109707-01 [1]				
9C	Gauge Glass	111271-01 [1]				
9D	Relief Valve	111267-01 [1]			111304-01 [1]	
9E	Pressure Limit Auto Reset, Honeywell	111280-01 [1]				
9F (CSD-1)	Pressure Limit Manual Reset, Honeywell	N/A			111281-01 [1]	
9G	LWCO Auto Reset, M&M	111272-01 [1]				
9H (CSD-1)	LWCO Manual Reset, Hydrolevel	N/A			111273-01 [1]	
Now Shown	Blocked Vent Switch (BVS)	109742-01 [2]				
Not Shown	Flame Rollout Switch (FRS)	109616-01 [2]				
Not Shown	Knock-Down Draw up Kit	111239-01 [1]				
Not Shown	Slip Nipple Kit	111582-01				

# 16 Service Parts *(continued)*



# 16 Service Parts *(continued)*

## Wiring

Key No.	Description	Part Number [Quantity]							
		49-075S	49-100S	49-125S	49-150S	49-175S	49-200S	49-250S	49-299S
10A	Main Harness, Power Harness	111264-01 [1]							
10B	Pilot Ground Wire	111278-01 [1]							
10C	Ignition Cable	111274-01 [1]							

Key No.	Description	Part Number [Quantity]				
		49-350S	49-399S	49-450S	49-500S	49-550S
10D	Main Harness, Power Harness	111265-01 [1]				
10E	Main Harness, Power Harness, CSD-1 Harness	111358-01 [1]				
10B	Pilot Ground Wire	111278-01 [2]				
10C	Ignition Cable	111274-01 [2]				

# 16 Service Parts *(continued)*

## Conversion Kit

111251-01: Input conversion kit 49-075S (49-100S to 75 MBH)

## Accessories

Key No.	Description	Part Number [Quantity]							
		49-075S	49-100S	49-125S	49-150S	49-175S	49-200S	49-250S	49-299S
Not Shown	Near Boiler Piping	111295-01 [1]				111296-01 [1]			N/A
Not Shown	HydroLevel CSD-1 Kit	111293-01 [1]							
Not Shown	LWCO Manual Reset, Hydrolevel	111273-01 [1]							
Not Shown	Pressure Limit Manual Reset, Honeywell	111281-01 [1]							

Key No.	Description	Part Number [Quantity]				
		49-350S	49-399S	49-450S	49-500S	49-550S
Not Shown	Hydrolevel CSD-1 Kit	111293-01 [1]		N/A		
Not Shown	LWCO Manual Reset, Hydrolevel	111273-01 [1]				
Not Shown	Pressure Limit Manual Reset, Honeywell	111281-01 [1]				
Not Shown	Gas Valve Leak Test Kit	N/A		111458-01 [1]		
Not Shown	CSD-1 Ignition Control Kit	N/A		111533-01 [1]		

# Appendix A Steam Boiler Skimming

## Steam Boiler Skimming

**ALL STEAM BOILERS REQUIRE PROPER SKIMMING. THIS NOTICE WILL HELP CONTRACTORS COMPLETE STEAM BOILER INSTALLATIONS AND AVOID CUSTOMER CALL-BACKS**

### Background

Skimming removes oil from the boiler water volume. If not removed properly oil can reduce steam generation and make the boiler surge. A boiler is surging when the water level in the gauge glass is bouncing or not visible while boiler is producing steam. Oil can originate from the inside of black pipe, or from petroleum based thread sealant or from the lubricant used in the cast iron hole threading process. Less than perfect near boiler piping may also make skimming more important.

This process combines best practices learned from a number of skilled, experienced technicians, and it can be completed in about an hour. No chemical additives should be needed.

### Recommended Skimming procedure:

1. Prepare at least two empty buckets. Find a close place to dump water.
2. Turn on the boiler. Run it until it is hot and starts to make steam.
3. Turn off the boiler. **IMPORTANT - DO NOT TURN BOILER ON DURING SKIMMING PROCESS.**
4. With Caution, lift valve and verify that there is no steam pressure in the boiler.
5. Find the skim tapping or a plug you can safely remove above the water level. This tapping must only be on the side of the boiler and at least 3/4". A relief valve side tapping may be used.
6. Install a nipple with a full-port ball valve into the boiler tapping. This valve is a "just-in-case" valve. You will not close this after the skimming process starts. This pipe nipple must be horizontal, and must come straight out. It can not elbow up. We are trying to skim the water surface, therefore the water must come off a horizontal pipe. There should not be water at this level yet.
7. Open the valve you installed. Hang a bucket on the pipe.
8. Find the manual fill valve. **If there is no manual valve, add the water to the boiler through the bottom drain valve on the boiler.**
9. Open the manual fill valve until the water starts to flow slowly out of the pipe nipple and valve installed earlier. When water flows out the pipe nipple, close the fill valve and wait until the flow stops.
10. Reopen the manual fill valve slightly so the steam of water coming from the pipe nipple is no larger than a wooden pencil. Slower flow is best.
11. Continue to skim until the bucket is almost full. Remove the full bucket and use the second bucket while you dump the first. Do not shut off the valve while doing this. You can not stop the water once you have started the flow. **Remember - Do not re-fire the boiler.**
12. Keep skimming until the water temperature is comfortable to the human hand.
13. When done skimming stop adding water. Drain the water to the proper fill level.
14. Remove the pipe nipple and valve. Re-install the plug or relief valve.
15. Turn the boiler back on and let it create steam. Decide if the surging stopped or improved. You may redo this process, but this should not be required.
16. If there is no improvement after two tries then the problem is not oil-related. Consider checking near boiler piping, flame impingement, or water pH. Low water pH or water treatment chemicals can also cause foaming and/or surging.

## Appendix B Indirect Water Heater

In this type of system, hot water is drawn from below boiler's NWL and passed through IWH's heat exchanger. This section describes boiler-side piping only. Refer to IWH Installation, Operating and Service Instructions for additional information. Components in this system and their functions are as follows:

1. Circulator - Mount circulator as shown in Figure B-1. Circulator should be located as low and as close to boiler as practical. Do not install valves, or other devices having a significant pressure drop, between boiler and circulator inlet. All piping between boiler and circulator inlet should be 1-1/4", regardless of piping size required in rest of the system.
2. "Y" Strainer - Install a "Y" strainer to prevent sediment from accumulating inside IWH's heat exchanger.
3. Check Valve - Prevents gravity circulation through IWH's heat exchanger when boiler is responding to a call for heat.

4. Boiler Limit Control - Use a SPST break-on-rise temperature limit control such as the Honeywell L4006A. Do not set limit above 180°F as doing so may cause boiler to steam when there is no call for heat. See Figure B-2 for wiring.
5. Valves and Unions - Install shut-off valves, drain valves, and unions in locations that will facilitate maintenance of the system. Do not install any valves between boiler and circulator inlet.

### NOTICE:

- Some IWHs may not be suitable for use with a steam boiler. Consult IWH manufacturer's guidelines before installing it in this type of system.
- Boiler water temperatures and flow rates in this type of system may be considerably lower than those upon which the IWH manufacturer's ratings are based. This may result in substantially longer water heater recovery times.

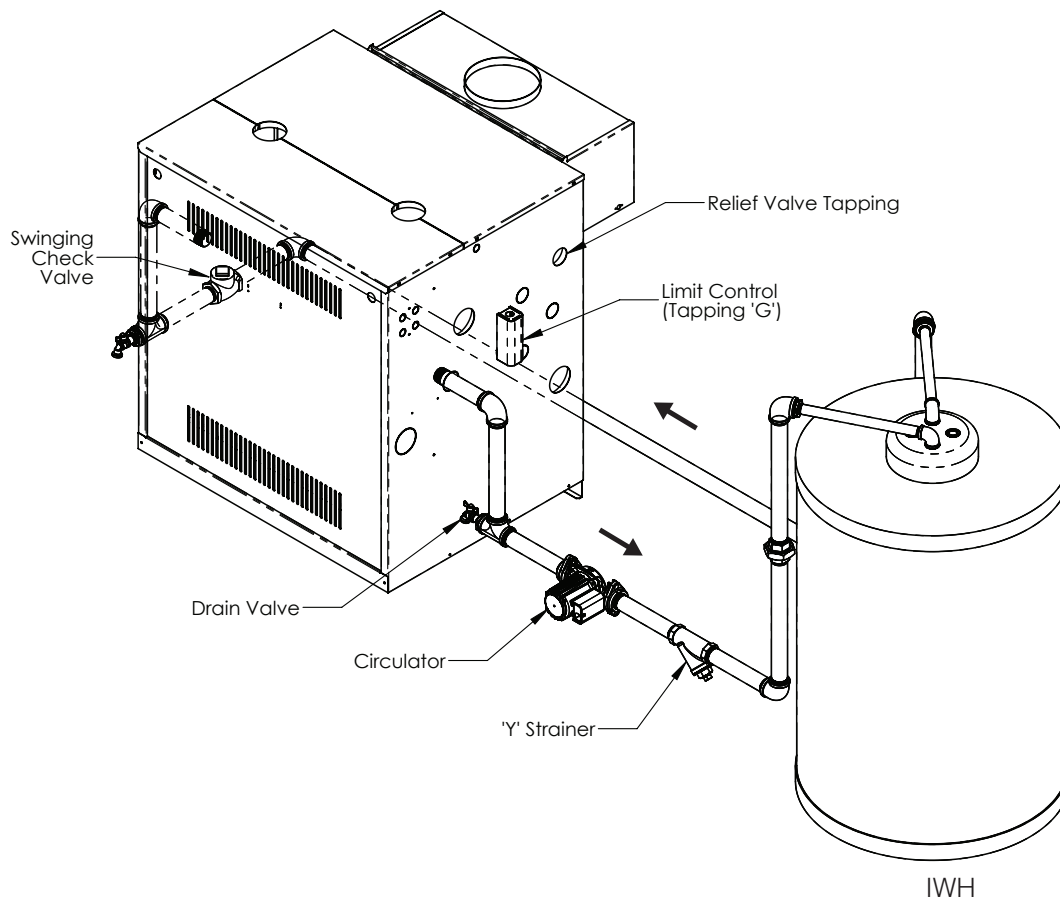


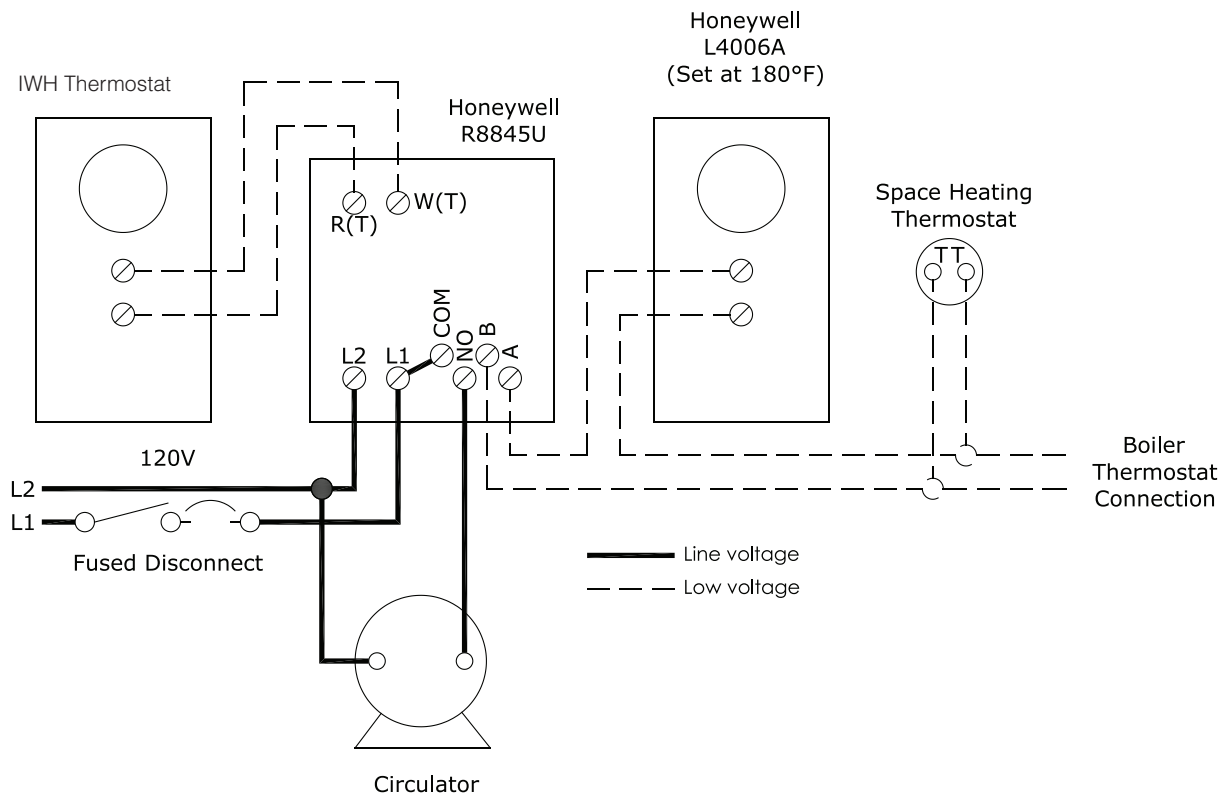
Figure B-1: Indirect Water Heater (IWH) Piping



## Appendix B Indirect Water Heater *(continued)*

6. Figure B-2 shows field wiring for an indirect water heater. A Honeywell R8845U or equivalent DPST relay and transformer is required. Limit control as described in Section 4 must also be supplied by installer. A call for heat from the IWH thermostat will energize relay making both sets of contacts. One contact energizes the circulator. Other contact will make boiler "T"- "T" circuit, firing burners. If boiler water temperature exceeds high limit setting of 180°F, high limit will open boiler "T"- "T" circuit and burners will shut down.

If there is a call for space heat, heating thermostat will make boiler "T"- "T" circuit and boiler will fire without regard to status of IWH. Auto reset LWCO and auto reset pressure limit will interrupt power to burner in event of a low water or excessive pressure condition.

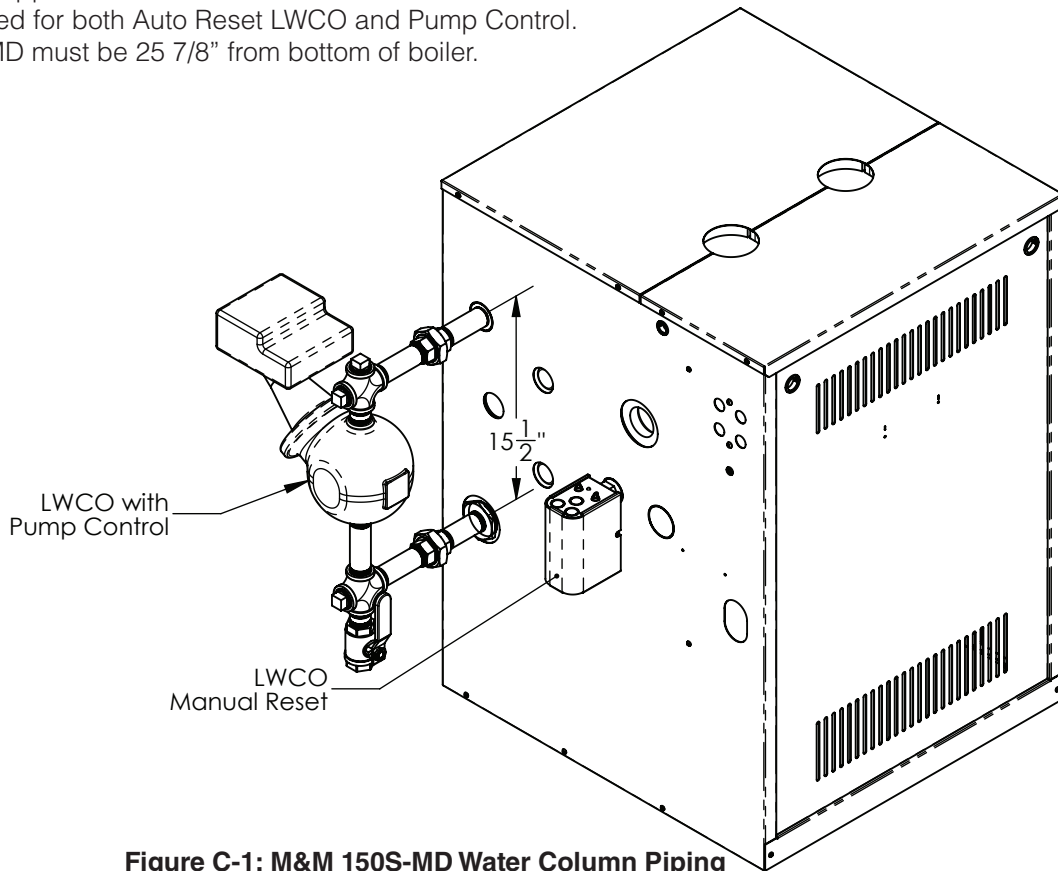


**Figure B-2: Indirect Water Heater (IWH) Wiring**

# Appendix C McDonnell & Miller 150S-MD Auto Reset LWCO/Pump Control

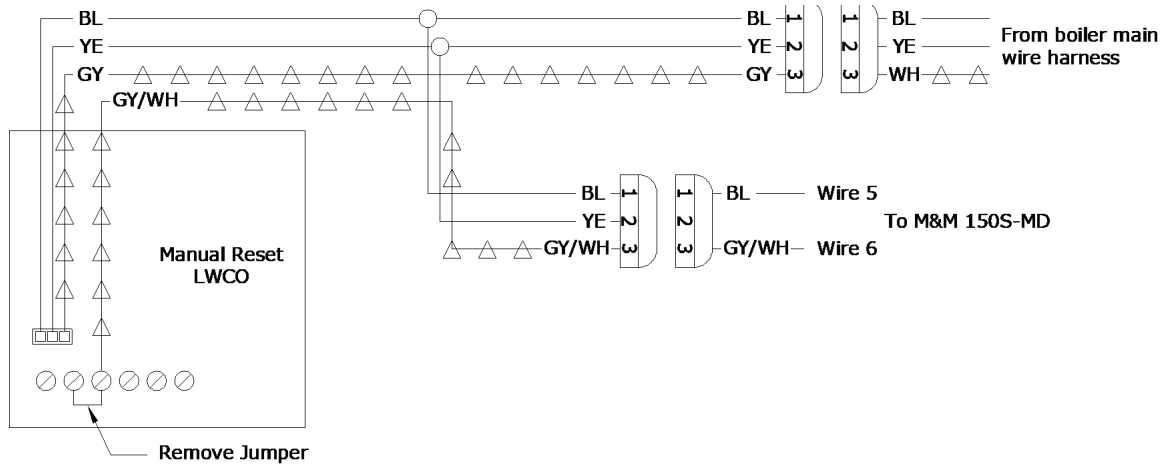
**NOTICE:** Follow Instruction Manual warnings provided with the 150S-MD.

- 150S-MD must be water column mounted on same side as Manual Reset LWCO. See Figure C-1.
- Auto Reset LWCO supplied with boiler will not be used.
- 150S-MD will be used for both Auto Reset LWCO and Pump Control.
- Cast line on 150S-MD must be 25 7/8" from bottom of boiler.



**Figure C-1: M&M 150S-MD Water Column Piping**

- Plug 150S-MD pig tail into Auto Reset LWCO connector on boiler wiring harness. See Figure C-2.
- Pig tail is located in either "CSD-1 MAN RESET LIMIT KIT" (111294-01) or "PARTS CARTON, CONTROLS" (110918-01).
- Wire blue lead to terminal 5 and gray/white lead to terminal 6 in 150S-MD.
- See Electrical Section for complete boiler wiring diagram.



**Figure C-2: Auto Reset LWCO Connector in Boiler Wiring Harness**



**Velocity Boiler Works, LLC  
P.O. Box 14818  
3633 I Street  
Philadelphia, PA 19134**