

Installation, Operating and Service Instructions for

PHANTOM II

- Combi Boiler/Water Heater
- Condensing
- Direct Vent
- Gas Fired

Models:

- PHTM2136C
- PHTM2136CB
- PHTM2200C

<u>Manual Contents</u>	<u>Page</u>
1. Installer Read Before Proceeding	3
2. Homeowner Read Before Proceeding	4
3. Specifications	5
4. How It Works	8
5. Locating Boiler	10
6. Preparing Boiler	14
7. General Venting	17
8. Sidewall Direct Venting	24
9. Vertical Direct Venting	30
10. Heating System Piping	36
11. Domestic Water Piping	39
12. Gas Piping	42
13. Field Wiring	43
14. Condensate Disposal	47
15. Start-Up and Checkout	48
16. Operation	55
17. Before Leaving Jobsite	67
18. Service and Maintenance	68
19. Troubleshooting	73
20. Internal Wiring Diagrams	91
21. Service Parts	94
22. Accessories	100

Appendix

A. Combination Refrigeration/Heating System .	101
B. Water Quality and Boiler Additives	102
C. Special Requirements In Massachusetts . . .	103
D. Code Required Text	105

TO THE INSTALLER:

Affix these instructions adjacent to boiler. Provide model number and serial number when seeking information and support.

TO THE HOMEOWNER:

Retain these instructions for future reference. Contact heating installer or technician for all issues and support.

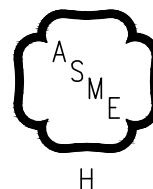

! WARNING

This boiler must only be installed, serviced, or repaired by a qualified heating installer or service technician. Improper installation, adjustment, alteration, service or maintenance can cause severe personal injury, death, or substantial property damage. For assistance or additional information, consult a qualified installer, service agency, or the gas supplier. Read these instructions carefully before installing.



The Massachusetts Board of Plumbers and Gas Fitters has listed the PHTM II Boiler. See the Massachusetts Board of Plumbers and Gas Fitters website for the latest Approval Code or ask your local Sales Representative. The Commonwealth of Massachusetts requires this product to be installed by a licensed Plumber or Gas fitter.

The following terms are used throughout this manual to bring attention to the presence of hazards of various risk levels, or to important information concerning product life.

 DANGER

Indicates a hazardous situation that, if not avoided, will result in death or serious injury.

 CAUTION

Indicates a hazardous situation that, if not avoided, could result in minor or moderate injury.

 WARNING

Indicates a hazardous situation that, if not avoided, could result in death or serious injury.

NOTICE: Indicates special instructions on installation, operation, or service which are important but not related to personal injury hazards.

 DANGER

Explosion Hazard. DO NOT store or use gasoline or other flammable vapors or liquids in the vicinity of this or any other appliance.

If you smell gas vapors, DO NOT try to operate any appliance - DO NOT touch any electrical switch or use any phone in the building. Immediately, call the gas supplier from a remotely located phone. Follow the gas supplier's instructions or if the supplier is unavailable, contact the fire department.

 WARNING

This boiler must only be serviced and repaired by qualified installer, service agency or gas supplier.

- If any controls are replaced, they must be replaced with identical models.
- Read, understand and follow all the instructions and warnings contained in all the sections of this manual.
- If any electrical wires are disconnected during service, clearly label the wires and assure that the wires are reconnected properly.
- Never jump out or bypass any safety or operating control or component of this boiler.
- Assure that all safety and operating controls and components are operating properly before placing the boiler back in service.
- Annually inspect boiler.
- Annually inspect all vent gaskets and replace any exhibiting damage or deterioration.

1 Installer or Qualified Service Agency Read Before Proceeding

WARNING

Asphyxiation Hazard, Burn Hazard, Electrical Shock Hazard.

- Carefully read all instructions in literature packet and posted on boiler before attempting installation, startup, or service of this boiler. Perform steps in order given. Failure to follow all instructions in proper order could result in severe personal injury, death or substantial property damage.
- Use proper personal protective equipment when installing, servicing, or working near this boiler. Materials of construction, flue products, and fuel contain alumina, silica, heavy metals, carbon monoxide, nitrogen oxides, and/or other toxic or harmful substances that can be hazardous to health and life and that are known to the State of California to cause cancer, birth defects, and other reproductive harm.
- Do not disconnect pipe fittings on boiler or in heating system without first verifying system is cool and free of pressure and that your clothing will protect you from a release of hot water or steam. Do not rely solely on boiler temperature and pressure gage when making this judgement.
- Install all guards, cover plates, and enclosures before leaving boiler in operation.
- Disconnect electrical supply before installing or performing maintenance.
- Always use a combustion analyzer to verify proper operation. See Section 15 Start-up and Checkout for procedure and guidelines for checking carbon monoxide (CO) levels. Failure to use a combustion analyzer could cause operation of boiler with elevated (CO) levels, resulting in severe personal injury, death or substantial property damage.
- Default altitude setting is 0-2,000 ft. (610 m). See Section 15: Start-up and Checkout for elevations above 2,000 ft. (610 m).
- For 200 combi LP installations above 2,000 ft. (610 m), conversion kit 111745-01 is required.

NOTICE: Size boiler properly relative to design heat load or, if using DHW priority, the peak hot water load, whichever is larger. A grossly oversized boiler will cycle excessively leading to premature failure of boiler and its components. Warranty does not cover damage from excessive cycling.

- For heating systems employing convection radiation (baseboard or radiators), use an industry accepted sizing method such as the I=B=R Guide RHH published by the Air Conditioning, Heating and Refrigeration Institute (AHRI).
- For new radiant heating systems, refer to radiant tubing manufacturer's boiler sizing guidelines.
- For system including indirect water heater, ensure boiler has output called for per indirect water heater manufacturer's instructions.

1. Phantom II Combi boiler is a Direct Vent combination space heating and DHW heating boiler.
2. A hot water boiler installed above radiation level or as required by the authority having jurisdiction must be provided with a low water cutoff (LWCO) device. This boiler is equipped with a UL353 listed flow switch which provides low water protection on this boiler. Where authority having jurisdiction requires a separate LWCO, the following kits are available:
 - Auto reset LWCO: 105591-01
 - Manual reset LWCO: 108182-01
 Factory installed flow switch in this boiler meets requirements of 248 CMR 5.00 Massachusetts Amendments to NFPA 54 Section 5.10(6) 10.3.5 Safety Control.
3. Inspect shipment carefully for signs of damage. See Figure 6-1 for location of parts shipped loose with boiler. Any claim for damage or shortage in shipment must be filed immediately against carrier by consignee. No claims for variances or shortages will be allowed by boiler manufacturer, unless presented within 60 days after receipt of equipment.

NOTICE: When replacing control, use boiler control service part listed in Section 21 Service Parts. Boiler control service part is compatible for all models. Factory installed control is only compatible with purchased boiler.

2 User/Homeowner Read Before Proceeding

⚠ WARNING

Asphyxiation Hazard. Fire Hazard.

- A qualified installer, service agency or gas supplier should annually inspect boiler including annually inspecting all vent gaskets and replacing any exhibiting damage or deterioration.
- If you are not qualified to install or service boilers, do not install or service this one.
- Carbon monoxide is an odorless, deadly gas that may be introduced into your home by any malfunctioning fuel burning product or vent system failure. **It is strongly recommended that CO alarms be installed near bedrooms and on all levels of building to warn you and your family of potential CO exposure.**
- Do not block air flow into or around boiler. Insufficient air may cause the boiler to produce carbon monoxide or start a fire.

⚠ CAUTION

Burn Hazard.

Keep children and pets away from hot surfaces of the boiler including boiler piping, vent piping, and vent terminals.

NOTICE: Boiler may leak water at the end of its useful life. Be sure to protect walls, carpets, and valuables from water that could leak from boiler.

⚠ DANGER

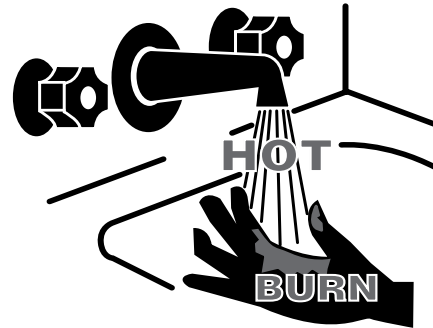

- Water temperature over 125°F (52°C) can cause severe burns instantly or death from scalds.
- Under certain conditions, this boiler can deliver hot water (DHW) at temperatures in excess of the DHW set point on boiler control.
- Children, disabled and elderly are at highest risk of being scalded.
- Feel water before bathing or showering.
- Installation of an ASSE 1017 or ASSE 1070 certified tempering valve is **REQUIRED** as part of this boiler's installation. See Section 11 Domestic Water Piping and authority having jurisdiction for additional details.
- Additional temperature control valves may also be required at fixtures. See Section 11 Domestic Water Piping and authority having jurisdiction for additional details.

NOTICE: Protect your home in freezing weather. A power outage, safety lockout, or component failure will prevent your boiler from lighting. In winter your pipes may freeze and cause extensive property damage. Do not leave heating system unattended during cold weather unless alarms or other safeguards are in place to prevent such property damage.

3 Specifications

Table 3-1: Ratings

Space Heating Ratings						Domestic Hot Water (DHW) Ratings ¹					
Model Number	Input ² (MBH)		DOE Heating Capacity (MBH)	AHRI Net Rating ³ (MBH)	AFUE	Input ² (MBH)		Hot Water Draw Limits GPM (L/min) ²			Min ⁴
	Min	Max				Min	Max	Max			
								70°F (39°C) Rise	77° (43°C) Rise	90°F (50°C) Rise	
PHTM2136C PHTM2136CB	13.6	120	112	97	95.0	13.6	136	3.7 (14)	3.4 (13)	2.9 (11)	0.5 (2)
PHTM2200C	20	150	141	123	95.0	20	200	5.2 (19.6)	4.7 (17.8)	4.0 (15)	0.5 (2)

¹ DHW ratings are not AHRI certified.

² Input and DHW draw limits for elevations up to 2,000 ft. (610 m) with min vent length. See Table 3-3 and 3-4 for derate at max vent length and altitude.

³ Net AHRI Water Ratings shown are based on a piping and pickup allowance of 1.15. The manufacturer should be consulted before selecting a boiler for installations having unusual piping and pickup requirements, such as intermittent operation, extensive piping systems, etc.

⁴ Min DHW flow rate required through boiler to initiate DHW demand. Higher flow rate through fixture may be required due to mixing at tempering valve and/or fixture itself.

Table 3-2: Dimensions and Connections

Model Number	Depth in. (mm)	Width in. (mm)	Height in. (mm)	Space Heating Water sweat, in.	Domestic Water sweat, in.	Gas NPT	Relief Valve NPT	Maximum Allowable Working Pressure psig (kPa)
PHTM2136C PHTM2136CB	16.3 (413)	17.8 (453)	29.8 (757)	1-1/4	3/4	1/2	3/4	50 (345)
PHTM2200C	20.4 (518)	17.8 (453)	29.8 (757)	1-1/4	3/4	1/2	3/4	50 (345)

3 Specifications *(continued)*

Table 3-3: Air Intake and Vent Lengths

Model Number	Intake/Vent Size in. (mm)		Min Length ft. (m)	Max Length ft. (m)	Approx. Derate at Max. Length (%)
PHTM2136C	Standard	2 (60)	2.5 (0.76)	70 (21.3)	7
PHTM2136CB	w/ increaser	3 (80)	2.5 (0.76)	135 (41.1)	1
PHTM2200C	Standard	2 (60)	2.5 (0.76)	70 (21.3)*	9
	w/ increaser	3 (80)	2.5 (0.76)	135 (41.1)	5

* Reduced to 50 eq. ft. (15.2 m) for 200 combi LP installation above 8,000 ft. (2,438 m)

Table 3-4: Altitude De-rates [%/1,000 ft. (305 m) Above Sea Level]

Boiler Model	2,000 to 6,000 ft. (611 m to 1,828 m)		6,000 to 8,000 ft. (1,829 m to 2,438 m)		8,001 to 10,000 (2,439 m to 3,079 m)	
	NG	LP	NG	LP	NG	LP
PHTM2136C	3.3%	5.3%	2.3%	3.7%	1.7%	2.8%
PHTM2136CB	2.0%	4.0%	1.5%	3.0%	1.2%	2.4%
PHTM2200C	0%	0%	0%	0%	0%	0%

NOTE: These de-rates are for minimum vent. When calculating de-rate from altitude and vent length, altitude de-rate is applied first.

Table 3-5: Inlet Gas Pressure Range

	Min in. wc (kPa)	Max in. wc (kPa)
Natural Gas	2.5 (0.62)	14.0 (3.48)
LP Gas	8.0 (1.99)	

Table 3-6: Weights and Volume

Model Number	Shipping Weight lb (kg)	Empty Boiler Weight lb (kg)	Shipping Crate D in. (mm)	Shipping Crate W in. (mm)	Shipping Crate H in. (mm)	Water Content gal (L)	Heat Exchanger Surface Area ft. ² (m ²)
PHTM2136C PHTM2136CB	112 (51)	95 (43)	41.4 (1050)	20.0 (508)	18.3 (465)	1.0 (3.8)	11.99 (1.11)
PHTM2200C	135 (62)	116 (53)	41.4 (1050)	20.0 (508)	22.3 (567)	1.3 (4.9)	17.98 (1.67)

Electrical Requirements: 120 VAC, 60 Hz, 1-ph. 1.6A for boiler and internal pump + current draw of any external pumps connected to boiler.

Controls: Boiler flow switch and integrated manual reset high limit provided with boiler are both UL-353 listed.

LP Gas Conversion: Boiler is shipped from factory configured for natural gas and is field convertible to LP gas. See Section 15 Start-up and Checkout for instructions to convert to LP gas.

Altitude: Only part no. containing H (i.e. PHTM2200CNG1HUA0) is listed for 0 to 10,100 ft. (3,079 m). See Section 15 Start-up and Checkout for altitude conversion instructions. For part no. containing S (i.e. PHTM2200CNG1SUA0), boiler is listed for 0 to 2,000 ft. (610 m). Do not install above 2,000 ft. (610 m).

3 Specifications *(continued)*

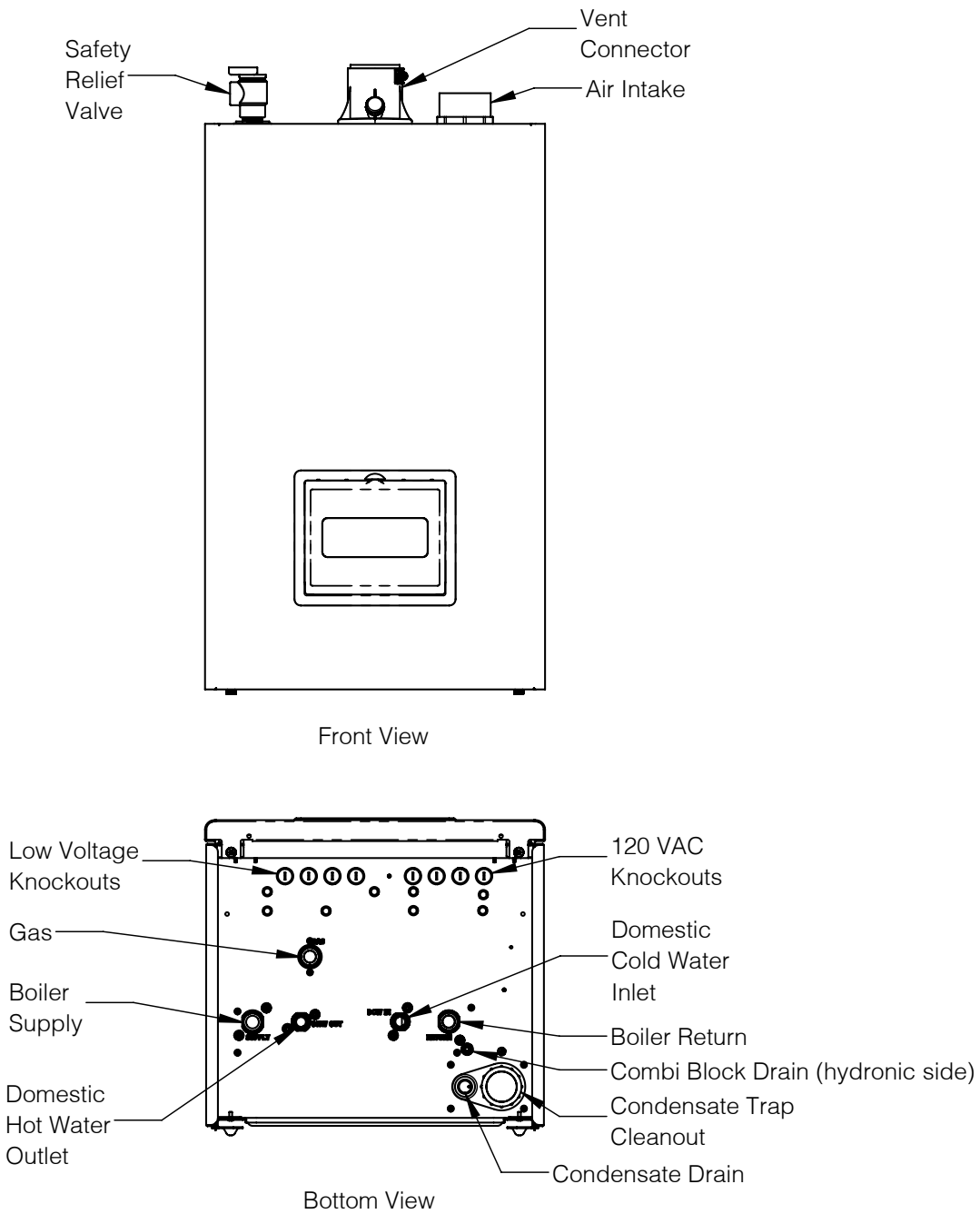

Figure 3-7: Boiler Connections

4 How It Works

1. **Heat exchanger**
Water flows through heat exchanger's stainless steel tubes. Heat is transferred to water as flue products are cooled below point of condensation for maximum heat transfer and efficiency. An enclosure contains and directs flue products to vent piping.
2. **Blower**
Pulls air and gas through venturi. Air and gas mixture is then pushed into burner where it burns inside combustion chamber.
3. **Gas valve**
Precisely controls gas flow rate in response to electronic signal from control.
4. **Venturi**
Creates suction at gas valve outlet and mixes air and gas before they flow into blower.
5. **Burner (not shown)**
Constructed of stainless steel, burner uses pre-mixed air and gas to meet modulation requirements.
6. **Boiler control (not shown)**
Monitors internal and external sensors and controls blower, gas valve, 3-way valve and pumps to meet heating and DHW demand. Control is a "gas adaptive system" that regulates air and gas flow mixture by measuring flame signal and adjusting gas valve to achieve a target air-fuel ratio. This eliminates need to make throttle screw or offset adjustments. System is self-calibrating and continuously maintains air-fuel ratio at desired value.
7. **120 VAC connection board**
Provides field connections for line voltage and two additional pumps (system pump and aux. pump).
8. **Low voltage connection board**
Provides field connections for thermostats, external limits, remote firing devices (4-20mA or 0-10V), header sensor, outdoor sensor and LWCO.
9. **Control enclosure**
Houses boiler control and provides access to installed fuses and spare fuses.
10. **Local user display**
Allows review of boiler status and parameter adjustment. In event of fault condition, LCD display turns red and fault condition is displayed.
11. **Flue temperature sensor**
Used to monitor flue gas exiting boiler. Boiler control will alarm, reduce boiler firing rate and shut down boiler if flue temperature is too high.
12. **Boiler supply temperature sensor (UL 353 Listed)**
Dual element temperature sensor used to monitor boiler water exiting heat exchanger. Boiler control uses supply temperature to initiate CH burner demand, adjust firing rate to maintain CH set point temperature and shut down the boiler if supply temperature is too high.
13. **Boiler return temperature sensor**
Used to monitor boiler water entering heat exchanger.
14. **Ignitor/flame sensor**
A single ignitor/flame sensor is used to both provide ignition energy and monitor flame.
15. **Air pressure switch**
Proves air flow (closes) prior to boiler ignition. Switch is proven open prior to starting blower.
16. **Boiler Pump**
Internal boiler pump provides flow through heat exchanger.
17. **Automatic air vent**
Connected to pump outlet, air vent helps remove air from water system.
18. **Boiler flow switch (UL 353 Listed)**
Proves water is present in boiler and flow rate is adequate prior to starting boiler.
19. **DHW flow sensor**
DHW flow sensor monitors DHW water demand. When DHW detects DHW draw greater than 0.5 gpm, boiler control initiates a DHW heat demand.
20. **Plate heat exchanger**
Heats domestic water using boiler water.
21. **3-way valve**
When DHW flow sensor detects flow and DHW has priority, 3-way valve is positioned to direct all boiler water to plate heat exchanger. When CH demand has priority, valve is positioned to direct all boiler water to CH zones. 3-way valve's default position is DHW.
22. **DHW temperature sensor**
Used to monitor DHW water leaving plate heat exchanger. Boiler control uses DHW water temperature to initiate DHW burner demand and adjusts boiler firing rate to maintain DHW setpoint temperature.
23. **Flow Limiter**
Provides flow restriction to 6 gpm (23 L/min). See Table 3-1 for DHW draw rates.
24. **Condensate trap (not shown)**
Allows combustion chamber and vent condensate to drain from boiler while retaining flue products in boiler.
25. **Combi Black Drain (not shown)** used to drain hydronic side water.

4 How It Works *(continued)*

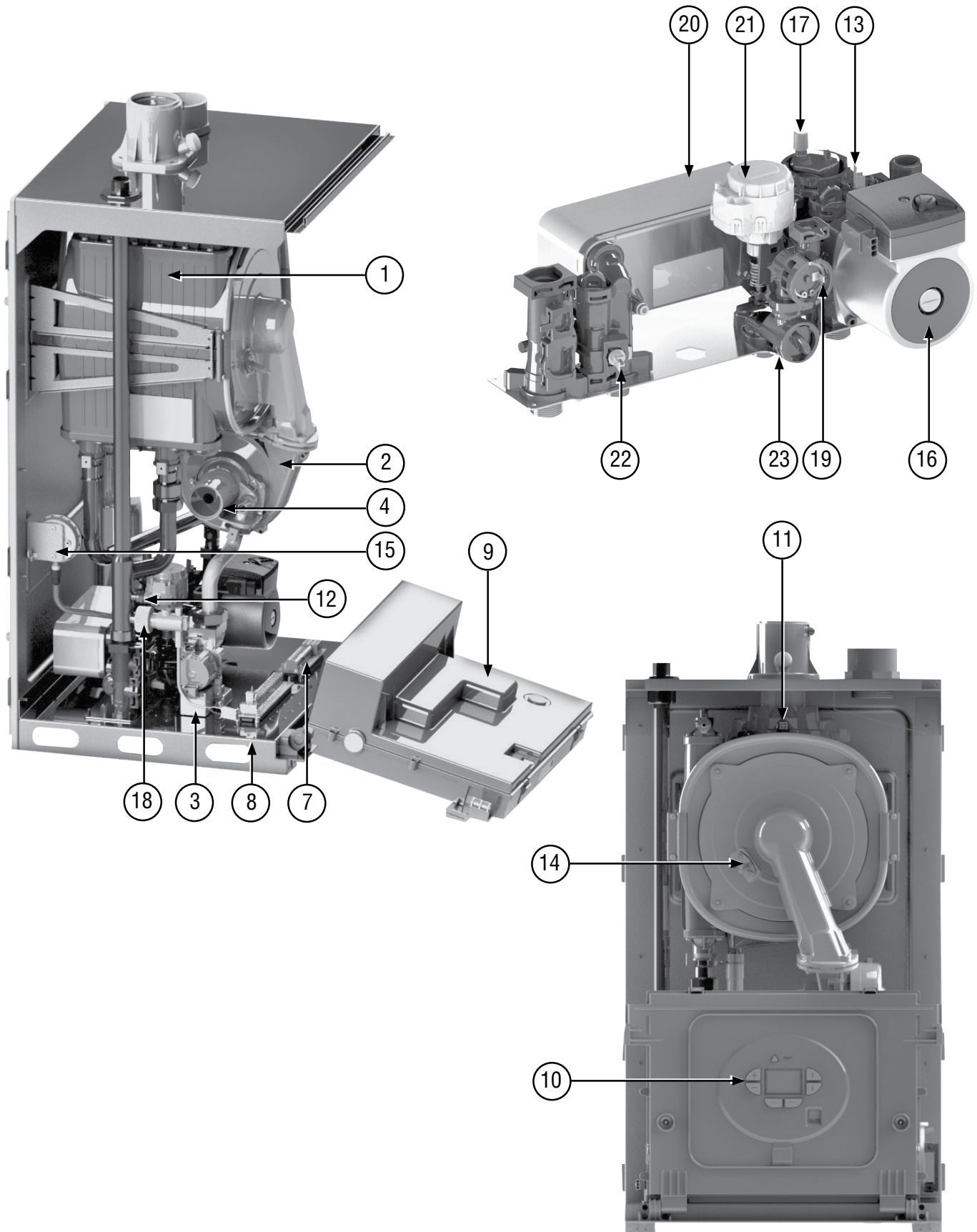

Figure 4-1: How It Works

5 Locating Boiler

Code Requirements

WARNING

Asphyxiation Hazard.

Adequate combustion and ventilation air must be provided to assure proper combustion and to prevent damage to boiler components. Provide ventilation openings into boiler room as described in "Air for Ventilation" in this manual. Combustion air must be brought to boiler from outdoors using an intake piping system meeting requirements in Section 7.

1. Installations must conform to the requirements of the authority having jurisdiction or, in the absence of such requirements, to the *National Fuel Gas Code*, ANSI Z223.1/NFPA 54, or *Natural Fuel Gas and Propane Installation Code*, CAN/CSA B149.1.
2. All wiring must comply with National Electrical Code ANSI/NFPA 70 (in the USA) or the Canadian Electrical Code CSA C22.1 (in Canada) and any local regulations.
3. Where required by authority having jurisdiction, installation must conform to *Standard for Controls and Safety Devices for Automatically Fired Boilers*, ANSI/ASME CSD-1.

Location Considerations

1. If replacing an existing boiler, check for and correct common system problems including:
 - A. System leaks, which can result in premature heat exchanger failure from oxygen corrosion or hardness deposits.
 - B. Inadequate freeze protection resulting in system freezing and leaking.
 - C. Dirt or debris left in existing piping if it has not been properly flushed or cleaned.
 - D. Incorrectly sized expansion tank.
2. Boiler is listed for indoor installation only. Do not install where boiler will be exposed to freezing temperatures or ambient air temperatures in excess of 104°F (40°C). Do not install in an attic.
3. Protect gas ignition system components from water (dripping, spraying, rain, etc.) during appliance operation and service (circulator replacement, condensate trap cleaning, control replacement etc.).

4. Locate boiler to avoid water damage in case there is a leak. If boiler must be located in an area sensitive to water damage, install drain pan underneath boiler and pipe to a suitable drain location. Manufacturer will not be held responsible for water damage resulting from this appliance or any of its components.
5. Check for and remove any combustible materials, gasoline, or other flammable liquids from area around boiler.
6. Check for and remove any potential combustion air contaminants from area around boiler and area around vent/air termination. See Table 5-2.

WARNING

Explosion Hazard.

Do not store or use gasoline or other flammable vapors or liquids in the vicinity of this or any other appliance. Do not install vent/air termination where gasoline or other flammable vapors or liquids are stored. Avoid locating vent/air termination near chemical products containing chlorine, chlorine based salts, chloro/fluorocarbons, paint removers, cleaning solvents, and detergents. Boiler could ignite vapors from flammable liquids resulting in explosion or fire.

Wall Mounting

1. Wall must be plumb and comprised of cement, brick, block, or wooden studs on 16 in. (406 mm) centers.
2. If flooding is possible, elevate boiler to prevent water reaching boiler.
3. Ensure boiler location minimizes risk of water damage from valves, pumps, etc.

Clearances

1. Provide clearances between boiler jacket and combustible material in accordance with authority having jurisdiction. Minimum clearances to combustible material shown in Figure 5-1.
2. Provide practical service clearances. 24 in. (610 mm) service clearance are recommended from left side, right side and front. If providing less than 24 in. (610 mm) front clearance, ensure access through a door. Minimum 6 in. (150 mm) clearance required to remove side panels.
3. Boiler must not be installed on carpeting.

NOTICE: If recommended service clearances are not provided, it may be necessary to remove boiler for service.

5 Locating Boiler *(continued)*

Ventilation Air

1. Combustion air must be obtained directly from outdoors, however ventilation openings may still be required to prevent overheating of boiler components if boiler is installed in small space such as a closet.
2. If a 24 in. clearance from boiler sides, front, and bottom can be maintained with all doors to the boiler room closed, no ventilation openings are required.

3. If 24 in. clearances described in (2) cannot be maintained, provide two openings into room, one near floor and other near ceiling. Top of upper opening to be within 12 in. (305 mm) of ceiling and bottom of lower opening within 12 in. (305 mm) of floor. Minimum free area 100 in.² (650 cm²) for each opening. This free area takes into account blocking effect of grills and louvers. If using screens, minimum screen size 1/4 in. (6.4 mm).

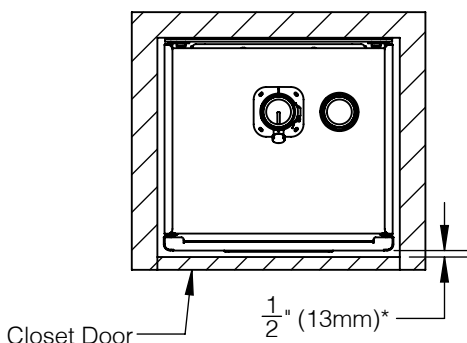

This boiler is listed for closet installation with the following clearances from the boiler jacket to combustible construction:

Top: 8¹/₄" (210mm), Sides: 1/2" (13mm),

Front: 1/2" (13mm), Bottom: 6" (150mm)

Clearances also apply to non-combustible walls, doors, ceilings and floors.

Clearances from piping to combustible construction:

Non-Concentric Vent (exhaust): 1/4" (6mm)

Concentric Vent or Air Intake Piping: 0"

Hot Water Piping: 1/4" (6mm)

*Recommended Service Clearances:

Sides, Front and Bottom: 24" (610mm)

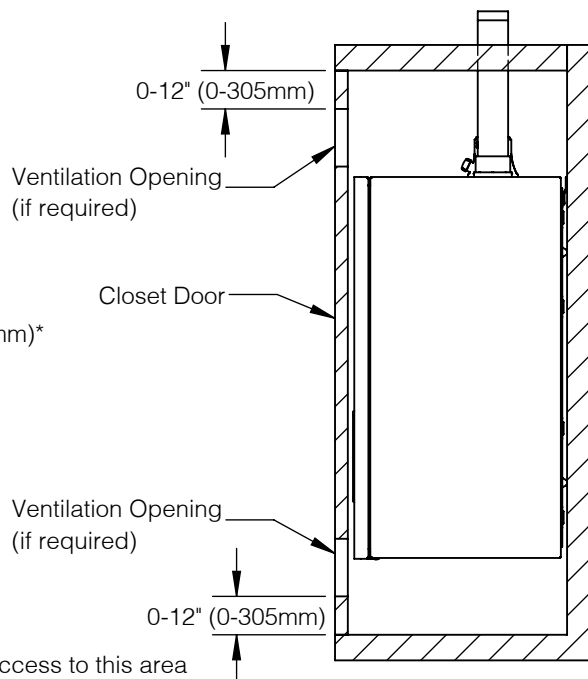
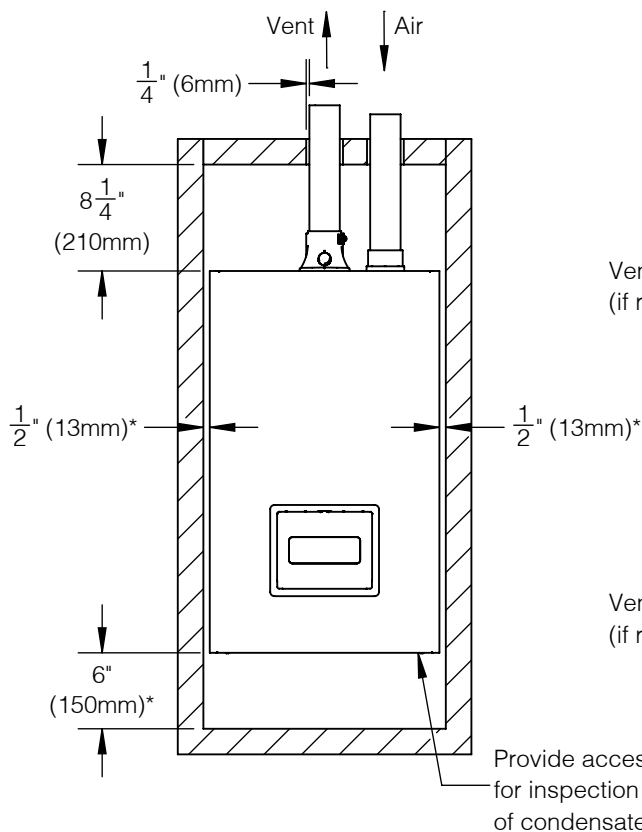

Figure 5-1 : Minimum Clearances to Combustible Construction

5 Locating Boiler *(continued)*

4. If boiler is installed in room with other appliances, provide adequate air for combustion and/or ventilation in accordance with other appliance manufacturer's instructions and applicable code. If other appliance(s) require two openings at least 100 in.² (650 cm²) each, no additional openings are required for this boiler.

Combustion Air and Venting

WARNING

Asphyxiation Hazard.

Boiler requires a special venting system designed for positive pressure. Supplied vent connector connects to CPVC, polypropylene, and stainless steel venting listed in Section 7, General Venting. Failure to vent boiler in accordance with these instructions could cause products of combustion to enter the building resulting in severe personal injury, death or substantial property damage.

DANGER

Component Malfunction.

Outdoor combustion air must be piped directly to boiler air connection. Ensure combustion air does not contain contaminants and is not drawn from an area likely to have contaminants per Table 5-2. For example, never pipe combustion air from areas near swimming pools or laundry room exhaust vents. Contaminated combustion air will damage boiler resulting in severe personal injury, death or substantial property damage.

1. Use only vent and air piping and termination methods listed in Section 7, General Venting. Vent and air piping must terminate either horizontally through a sidewall or vertically through a roof or chase. Locate boiler so vent and air intake piping can be routed through building and properly terminated.
2. Ensure installation does not exceed maximum air and vent pipe lengths and terminations are located in acceptable location per these instructions and all applicable local codes.

Table 5-2: Corrosive Combustion Air Contaminants and Sources

Contaminants to avoid:
Spray cans containing chloro/fluorocarbons (CFC's)
Permanent wave solutions
Chlorinated waxes/cleaners
Chlorine-based swimming pool chemicals
Calcium chloride used for thawing
Sodium chloride used for water softening
Refrigerant leaks
Paint or varnish removers
Hydrochloric acid/muriatic acid
Cements and glues
Antistatic fabric softeners used in clothes dryers
Chlorine-type bleaches, detergents, and cleaning solvents found in household laundry rooms.
Adhesives used to fasten building products and other similar products
Excessive dust and dirt
Areas likely to have contaminants:
Dry cleaning/laundry areas and establishments
Swimming pools
Metal fabrication plants
Beauty shops
Refrigeration repair shops
Photo processing plants
Auto body shops
Plastic manufacturing plants
Furniture refinishing areas and establishments
New building construction
Remodeling areas
Garages with workshops

5 Locating Boiler *(continued)*

Connecting New Boiler to Existing Vent System

WARNING

Asphyxiation Hazard.

If any of below conditions cannot be met, existing vent system must be updated or replaced. Failure to follow these instructions could cause products of combustion and/or carbon monoxide to enter living space, resulting in severe personal injury, death or substantial property damage.

1. If using existing vent system to vent new boiler, check the following:
 - A. Material and manufacturer are listed in Section 7 General Venting.
 - B. Proper size and length per Table 7-7.
 - C. Appropriate supports to prevent sagging and vertical movement.
 - D. Minimum slope per Section 7 guidelines.
 - E. Terminations and their location comply with Section 7 General Venting, Section 8 Sidewall Direct Venting, or Section 9 Vertical Direct Venting.
 - F. Seals and connections per Section 7 General Venting and/or vent system manufacturer's instructions. System must be tested per procedure Removing Existing Boiler in this section.
 - G. Vent pipe and components should be replaced if there is any question to their integrity.

Removing Existing Boiler

DANGER

Asphyxiation Hazard.

Do not vent this boiler into a common vent with any other appliance. Connecting this boiler to a common vent will cause products of combustion and/or carbon monoxide to enter living space as well as appliance malfunction, resulting in severe personal injury, death or substantial property damage.

When an existing boiler is removed from a common venting system, the common venting system is likely to be too large for proper venting of the appliances remaining connected to it.

At the time of removal of an existing boiler, the following steps shall be followed with each appliance remaining connected to the common venting system placed in operation, while the other appliances remaining connected to the common venting system are not in operation:

1. Seal any unused openings in the common venting system.
2. Visually inspect the venting system for proper size and horizontal pitch and determine there is no blockage or restriction, leakage, corrosion, and other deficiencies which could cause an unsafe condition.
3. Insofar as is practical, close all building doors and windows and all doors between the space in which the appliances remaining connected to the common venting system are located and other spaces of the building. Turn on clothes dryers and any appliance not connected to the common venting system. Turn on any exhaust fans, such as range hoods and bathroom exhausts, so they will operate at maximum speed. Do not operate a summer exhaust fan. Close fireplace dampers.
4. Place in operation the appliance being inspected. Follow the Lighting (or Operating) Instructions. Adjust thermostat so appliance will operate continuously.
5. Test for spillage at the draft hood relief opening after 5 minutes of main burner operation. Use the flame of a match or candle, or smoke from a cigarette, cigar or pipe.
6. After it has been determined that each appliance remaining connected to the common venting system properly vents when tested as outlined above, return doors, windows, exhaust fans, fireplace dampers and any other gas-burning appliance to their previous condition of use.
7. Any improper operation of the common venting system should be corrected so the installation conforms with the *National Fuel Gas Code*, ANSI Z223.1/NFPA 54. When resizing any portion of the common venting system, the common venting system should be resized to approach the minimum size as determined using the appropriate tables in Chapter 13 of the *National Fuel Gas Code*, ANSI Z223.1/NFPA 54.

Residential Garage Installation

1. If installing in residential garage or adjacent space open to garage that is not part of living space:
 - A. Burner and burner ignition devices must be a minimum of 18 in. (46 cm) above floor.
 - B. Boiler must be located and/or protected to prevent damage from moving vehicle.
2. Follow local codes for locating a residential boiler in a garage or *National Fuel Gas Code*, ANSI Z223.1/NFPA 54. in absence of such codes.

6 Preparing Boiler

Unpack Boiler

Remove boiler and miscellaneous parts carton from outer shipping carton.

CAUTION

Boiler Damage.

- Do not attempt to lift boiler using water or gas pipe connection as hand holds.
- Do not drop boiler. Damage to boiler can result.
- Do not rest boiler on bottom with side panels removed. Boiler should be hung from wall bracket.

CAUTION

Heavy Object.

Boiler weighs up to 130 lb (59 kg). Two people are required to lift boiler onto wall mounting bracket. Ensure wall bracket is anchored to structure capable of supporting weight of boiler and attached piping when filled with water. Areas subject to earthquakes may have special requirements that take precedence over requirements in these instructions.

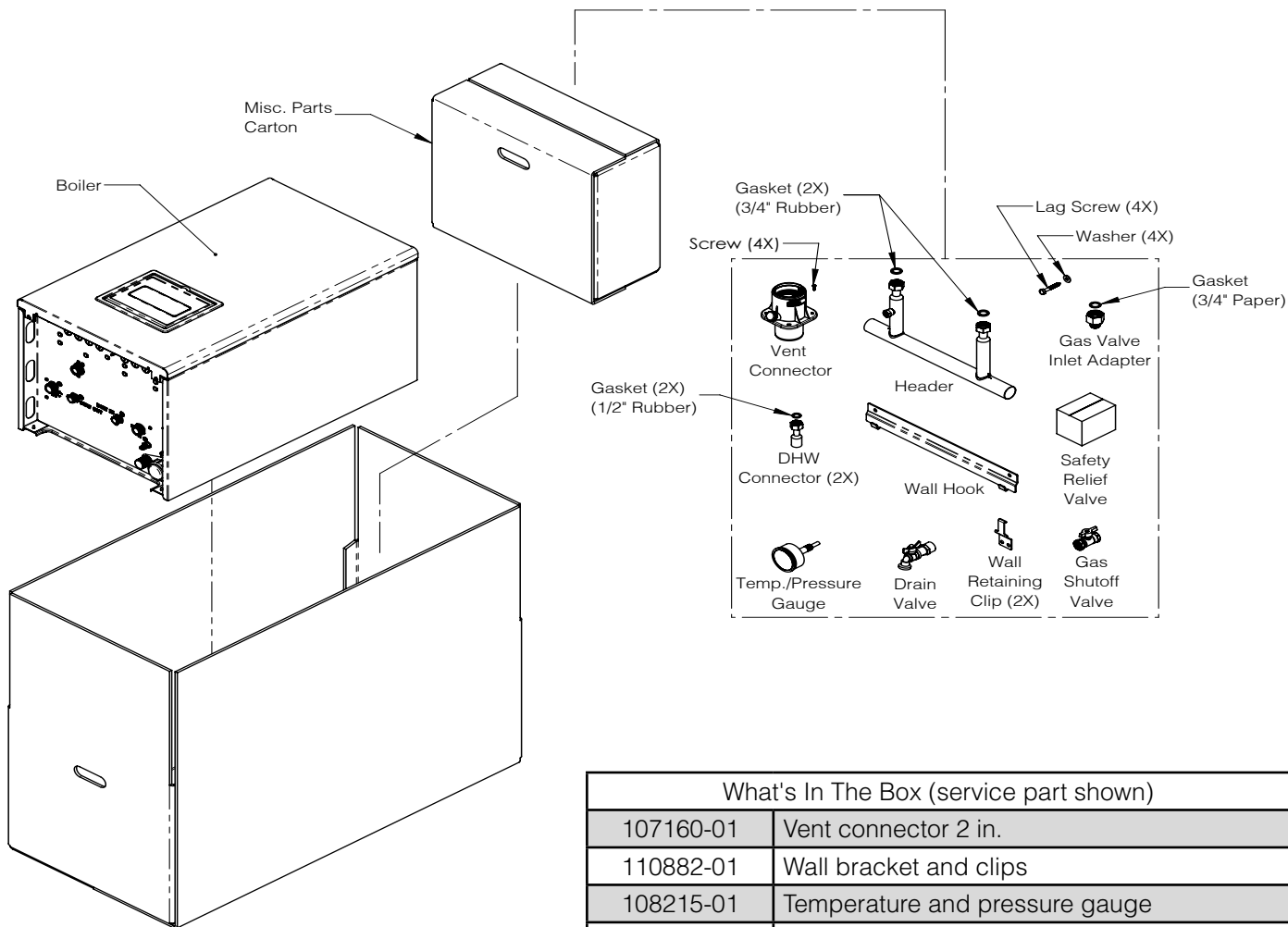

What's In The Box (service part shown)	
107160-01	Vent connector 2 in.
110882-01	Wall bracket and clips
108215-01	Temperature and pressure gauge
110878-01	DHW connection fittings (2) metric to copper
111422-01	Adapter gas metric to 1/2 in. NPT
108680-01	Relief valve 30 PSIG
110724-01	Low loss header combi (only)

Figure 6-1: What's In The Box

6 Preparing Boiler *(continued)*

Install Vent Connector

1. Remove vent connector and screws from miscellaneous parts carton.
2. Check vent reducer on top of heat exchanger to ensure it is installed properly.

WARNING

Asphyxiation Hazard.

A boiler operating with an improperly installed vent reducer (3 in. to 2 in.) could cause unreliable operation at elevated carbon monoxide levels resulting in severe personal injury, death, or substantial property damage.

3. Lubricate heat exchanger vent gasket with soapy water.
4. Insert vent connector through jacket into heat exchanger with flue gas sample port facing forward. See Figure 6-2.
5. Tighten 4 screws.

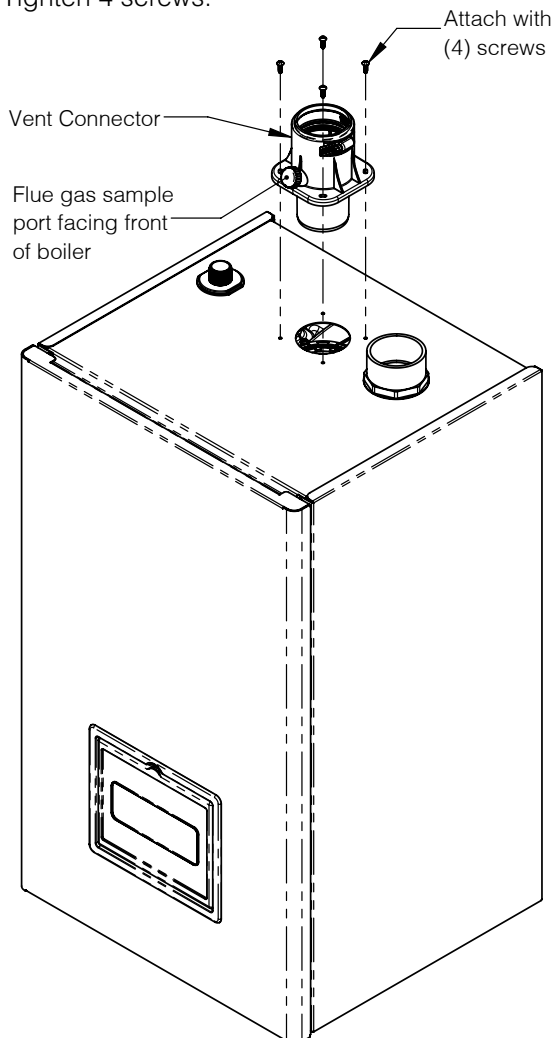

Figure 6-2: Installing Vent Connector

Preparing for Fuel Conversion

If using LP gas. LP conversion requires (2) steps: gas valve setting adjustment and control parameter change.

1. Use 2.5 mm hex wrench to adjust gas valve setting from "1" to "2" (Figure 6-3). For easy access to gas valve remove left side panel using (2) Phillips screws. (136 combi only)
2. See Section 15 "Start-Up and Checkout" for Control Parameter adjustment instructions.

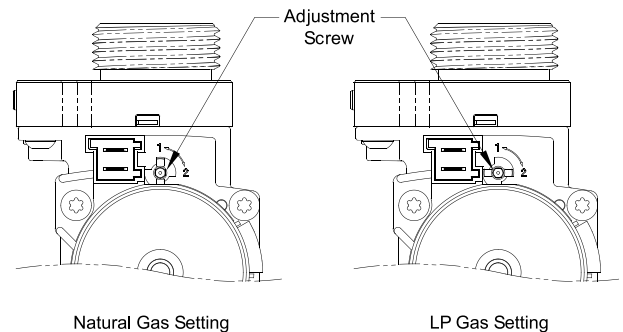

Figure 6-3: Gas Valve Fuel Setting

6 Preparing Boiler *(continued)*

Mount Boiler

1. Wall bracket is designed to mount on studs with 16 in. (406 mm) centers or a masonry wall. For other stud spacing, mount bracket to 3/4 in. (19 mm) plywood or horizontal 2 x 4 anchored to studs.

CAUTION

Heavy Object.

Do not mount boiler to a hollow wall. Boiler must be anchored to studs.

2. Mark wall bracket hole locations using dimensions shown in Figure 6-4. Ensure bracket is level.

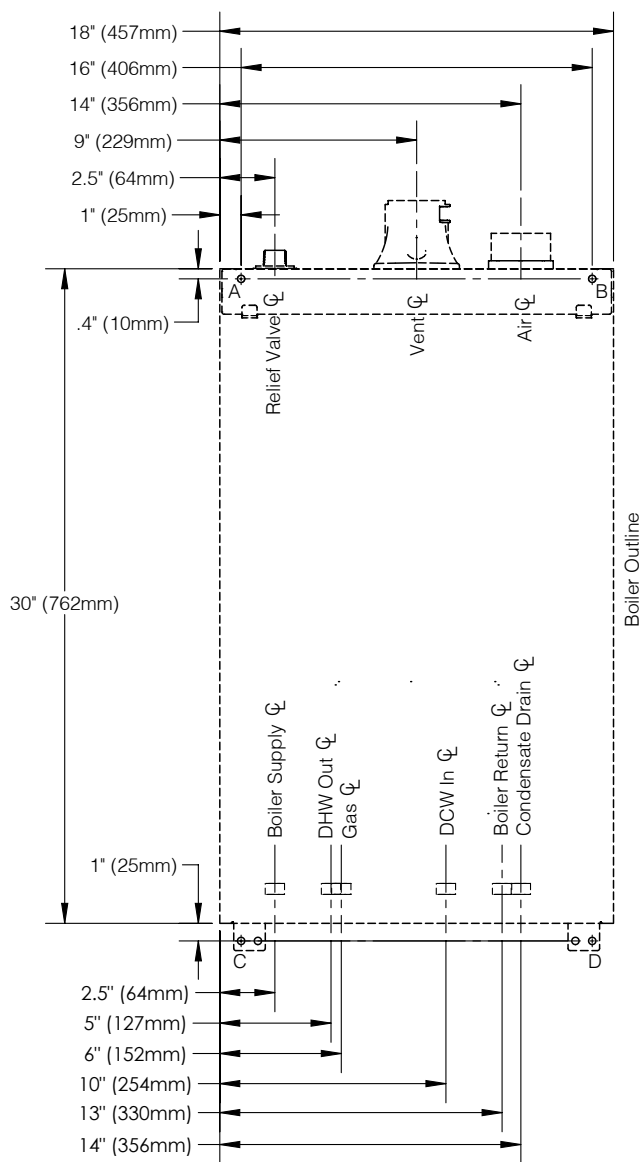

Figure 6-4: Wall Layout and Mounting Holes

3. For wood studs, drill 3/16 in. (4.8 mm) pilot holes "A" and "B" and attach bracket using provided 5/16 in. x 2 in. lag screws and washers. For wood studs with drywall or paneling greater than 1/2 in. (12 mm) thick, metal studs, or masonry wall, use anchors suitable for boiler weight and appropriate for wall material.
4. Hang boiler on wall bracket. See Figure 6-5.
5. Attach bottom retaining clips to boiler and mark hole locations. Drill 3/16 in. (4.8 mm) pilot holes "C" and "D" and attach to wall using provided 5/16 in. x 2 in. lag screws or other anchors appropriate for wall material.
6. Verify boiler is level and plumb.

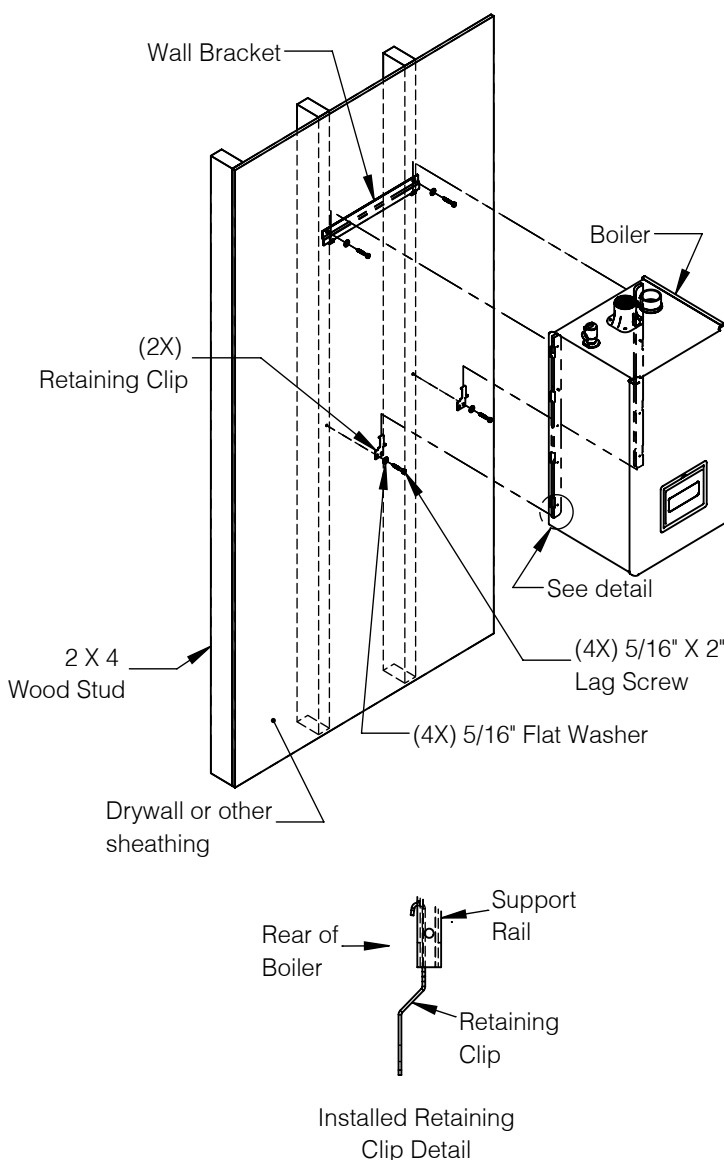

Figure 6-5: Mounting Boiler on Wall

7 General Venting

Direct Vent Sidewall Termination Options

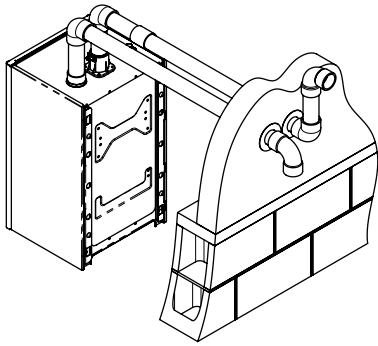

Figure 7-1: Sidewall Termination with Fittings - see Section 8 for details

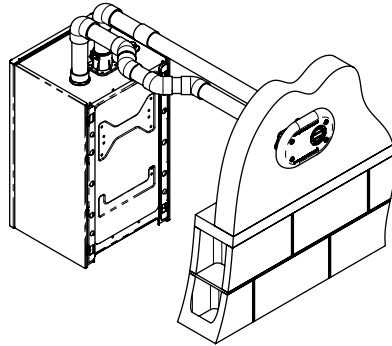

Figure 7-2: Sidewall Low Profile Termination - see Section 8 for details

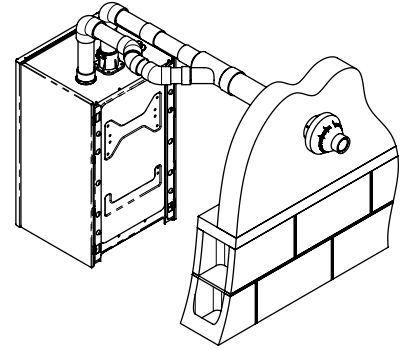

Figure 7-3: Sidewall Concentric Termination - see Section 8 for details

Direct Vent Vertical Termination Options

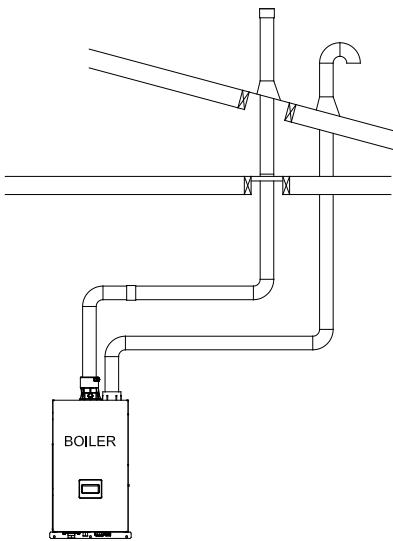

Figure 7-4: Vertical Termination with Fittings - see Section 9 for details

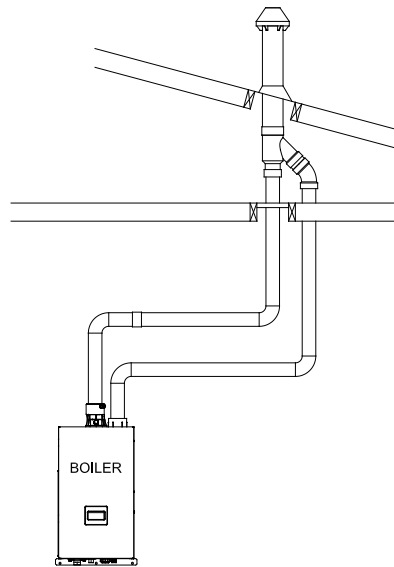

Figure 7-5: Vertical Concentric Termination - see Section 9 for details

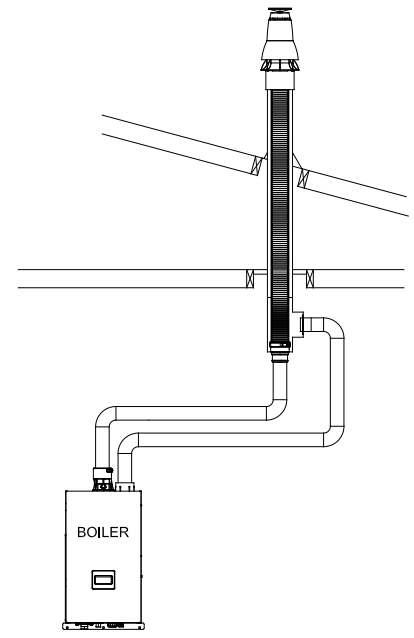

Figure 7-6: Vertical Termination with Abandoned B-vent or Chimney Chase - see Section 9 for details

7 General Venting *(continued)*

Vent and Air Sizing

WARNING

Asphyxiation Hazard.

- Failure to vent this boiler in accordance with these instructions could cause products of combustion and/or carbon monoxide to enter living space, resulting in severe personal injury, death or substantial property damage.
- Vent installations shall be in accordance with provisions of the National Fuel Gas Code, ANSI Z223.1/NFPA 54, or "Natural Gas and Propane Installation Code, CAN/CSA B149.1, or applicable requirements of the local building codes.
- This boiler requires a special venting system. Use only CPVC, PVC, or polypropylene venting systems listed in Tables 7-11 or 7-16.
- Thoroughly inspect finished vent and air piping to ensure air-tightness and compliance with provided instructions and code requirements.
- Do not mix components from different venting systems.
- Covering non-metallic vent pipe and fittings with thermal insulation is prohibited.
- Follow all local codes for isolation of vent pipe when passing through floors or walls.
- Do not use a barometric damper, draft hood, or vent damper with this boiler.
- Do not connect any other appliance to vent pipe or multiple boilers to a common vent pipe.
- Follow instructions in Section 5, Locating Boiler, when removing a boiler from an existing vent system.
- Failure to comply with any of the above requirements could result in severe personal injury, death or substantial property damage.

Table 7-7: Vent and Air Sizing

Model Number	Vent/Air Size in. (mm)	Min Equivalent Length ft. (m)	Max Equivalent Length ft. (m)
All Sizes	2 (60)	2.5 (0.76)	70 (21.3)*
	3 (80)	2.5 (0.76)	135 (41.1)

*Reduced to 50 eq. ft. (15.2 m) for 200 combi LP installations above 8,000 ft. (2,438 m).

See Table 3-3 for max vent de-rate.

1. Min and max lengths are calculated separately for air and vent. For example, max length 135 ft. (41.1 m) means up to 135 ft. (41.1 m) air piping and up to 135 ft. (41.1 m) vent piping.
2. If using 2 in. x 3 in. increaser, use max 12 in. (305 mm) of 2 in. pipe before increaser. For equivalent length, count only 3 in. (80 mm) pipe starting from increaser.
3. Maximum length of flexible polypropylene venting is reduced due to higher pressure drop. See Table 7-10.
4. If using B-vent air chase, 1 ft. (0.30 m) B-vent equals 1 equivalent ft. (0.30 m).

Table 7-8: CPVC/PVC Fitting Equivalent Lengths

Fitting	Equivalent Length ft. (m)	
	2 in.	3 in.
90° Short Elbow	6.0 (1.8)	10 (3.0)
90° Sanitary Elbow	2.6 (0.8)	4.0 (1.2)
45° Elbow	1.5 (0.5)	2 (0.6)

Table 7-9: Rigid PolyPro Fitting Equivalent Lengths

	DuraVent PolyPro	Centrotherm InnoFlue	Selkirk PolyFlue
2 in. (60 mm) 45° elbow	3 ft. (0.91 m)	3 ft. (0.91 m)	3.3 ft. (1.0 m)
2 in. (60 mm) 90° or 87° elbow	5 ft. (1.5 m)	5 ft. (1.5 m)	4.8 ft. (1.5 m)
3 in. (80 mm) 45° elbow	3 ft. (0.91 m)	3 ft. (0.91 m)	3.6 ft. (1.1 m)
3 in. (80 mm) 90° or 87° elbow	7 ft. (2.1 m)	7 ft. (2.1 m)	7.2 ft. (2.2 m)

Table 7-10: Flexible Polypropylene Equivalent Length for 1 ft. (0.30 m) Measured Length

	DuraVent PolyPro Flex	Centrotherm InnoFlue Flex	Selkirk Polyflue Flex
2 in. (60 mm)	2 ft. (0.61 m)	2.5 ft. (0.76 m)	2.5 ft. (0.76 m)
3 in. (80 mm)	2 ft. (0.61 m)	2.3 ft. (0.70 m)	2.3 ft. (0.70 m)

WARNING

Asphyxiation Hazard.

2 in. (60 mm) max vent length reduced to 50. eq. ft. (15.2 m) for 200 combi LP installations above 8,000 ft. (2,438 m). Failure to comply could cause unreliable operation at elevated carbon monoxide (CO) level, resulting in severe personal injury, death or substantial property damage.

7 General Venting *(continued)*

5. Example equivalent length calculation for 2 in. vent:
 - A. 1 ft. CPVC straight pipe = 1 eq ft.
 - B. 90° CPVC short elbow = 6 eq ft.
 - C. 1.5 ft. CPVC straight pipe = 1.5 eq ft.
 - D. Coupling = 0 eq ft.
 - E. 10 ft. PVC straight pipe = 10 eq ft.
 - F. 90° PVC sanitary elbow = 2.6 eq ft.
 - G. 15 ft. PVC straight pipe = 15 eq ft.
 - H. PVC coupling (terminal) = 0 eq ft.
 - I. Total vent length = 36.1 eq ft.
(acceptable length per Table 7-7)
6. Listed Air Piping Materials
 - A. PVC/CPVC
 - B. Polypropylene
 - C. B-vent double wall vent (with joints and seams sealed with RTV silicone)
7. Listed Vent Materials
 - A. CPVC/PVC - See Table 7-11
 - B. Polypropylene - See Table 7-16

CPVC/PVC Venting

WARNING

Asphyxiation Hazard.

- Use only vent materials, primer, and cement listed in Table 7-11 to make vent connections.
- Use of cellular core PVC (ASTM F891), cellular core CPVC, or Radal® (polyphenolsulfone) in venting systems is prohibited.
- PVC vent systems must include at least 30 in. (760 mm) of CPVC pipe and one CPVC elbow between boiler and PVC vent piping.
- CPVC is required within any interior space where air cannot circulate freely, including a vertical or horizontal chase, inside a stud wall, in a closet, and through wall penetrations.
- Maintain clearances to vent piping per Figure 5-1.
- Failure to comply with venting instructions could cause products of combustion and/or carbon monoxide to enter the building, resulting in severe personal injury, death or substantial property damage.

WARNING

Asphyxiation Hazard.

All CPVC/PVC vent joints must be glued. Failure to comply could cause products of combustion and/or carbon monoxide to enter the building, resulting in severe personal injury, death or substantial property damage.

NOTICE: PVC may not be used to penetrate combustible or non-combustible walls unless all of the following conditions are met. If any of these conditions cannot be met, use CPVC for wall penetration. See Figure 7-14.

- Wall penetration is at least 66 in. (1.7 m) from boiler measuring along vent pipe.
 - Wall is less than or equal to 12 in. (305 mm) thick.
 - Air space shown in Figure 7-14 is maintained around outside diameter of vent.
1. Slope CPVC/PVC vent pipe not less than 1/4 in. per foot (21 mm per m) upwards from boiler to vent terminal for condensate drainage.
 2. Support CPVC/PVC pipe at intervals not exceeding 4 ft. (1.2 m).
 3. Be sure to use appropriate primer and cement when joining CPVC to PVC. The following or equivalent may be used to join CPVC to PVC:
 - A. Primer: IPS P-70
 - B. Cement: IPS 790

Table 7-11: Listed CPVC/PVC Vent Materials

	Material	Standard
Vent Pipe	CPVC, sched. 40 or 80	ASTM F441
	PVC, sched. 40 or 80	ASTM D1785
	PVC, DWV	ASTM D2665
Vent Fittings	CPVC, sched. 80	ASTM F439
	PVC, sched. 40	ASTM D2466
	PVC, sched. 80	ASTM D2467
	PVC, DWV	ASTM D2665
Primer/Cement	CPVC	ASTM F493
	PVC	ASTM D2564

NOTICE: In Canada, CPVC and PVC vent pipe, fittings, and cement/primer must be ULC-S636 listed.

4. Work from boiler towards vent or air termination. Do not exceed maximum equivalent lengths shown in Table 7-7. See Table 7-8 for equivalent lengths of elbows and fittings.
5. Starting from the boiler, first 30 in. (760 mm) of vent pipe and first elbow must be CPVC. 30 in. (760 mm) CPVC pipe may be cut at any location and CPVC elbow installed between two resulting CPVC pipes before transitioning to PVC. PVC coupling may be used to join CPVC to PVC vent piping. See Figure 7-12.

7 General Venting *(continued)*

6. CPVC/PVC vent starter kits are available. Kits include 30 in. (760 mm) CPVC pipe, 90° short CPVC elbow, PVC coupling (vent terminal), 90° short PVC elbow (air terminal), and 2 terminal screens. Components in these kits are not ULC-S636 listed and are therefore not usable in Canada.
 - A. 2 in. kit: 107039-01
 - B. 3 in. kit: 111945-01
7. Allow for 3/8 in. (9.5 mm) of thermal expansion per 10 ft. (3.0 m) of CPVC/PVC pipe. If a straight run of pipe exceeds 20 ft. (6.0 m) and is restrained at both ends, an offset or expansion loop is required per Figure 7-15. If a straight horizontal run of pipe exceeds 20 ft. (6.0 m) and is restrained at one end with an elbow at the other, ensure hanger or guide is not less than Y in from elbow per Figure 7-15. Thermal expansion fittings not permitted.
8. All air piping may be PVC.
9. Vent and air can be up-sized to 3 in. for longer runs. If upsizing to 3 in. vent material, the following is required:
 - A. 2 in. CPVC vent piece (max 12 in. 305 mm) (field supplied).
 - B. 2 in. x 3 in. CPVC increaser (field supplied, Lasco 9829-338, Spears 829-338C or IPEX 9829338 or equivalent).
 - C. 3 in CPVC/PVC vent starter kit (purchased separately, see above).
 - D. Similar PVC fittings for air intake.

NOTICE: Increaser must be installed in vertical section of pipe. See Figure 7-13.

10. Cut pipe squarely and debur inside and outside of pipe ends after cutting.
11. Dry fit all vent and air components before cementing any joints.
12. Use field supplied primer and cement appropriate for materials being joined. Follow primer and cement instructions to join pipe and fittings.
13. Clean all pipe ends and fittings with appropriate primer before cement. Apply primer to both pipe and fitting socket before applying cement.
14. Boiler vent connector is gasketed. Lubricate gasket with soapy water, insert pipe until it bottoms out, and tighten clamp.
15. Boiler air connector in PVC socket fitting. Drill 7/32 in. (5.5 mm) hole in air connector. Drill 1/8 in. (3.2 mm) hole in air pipe to align with hole in connector. Insert pipe into air connector and

use #10 x 1 in. sheet metal screw to secure. Seal joint between air connector and pipe with RTV silicone.

16. To the extent possible, slope horizontal air piping towards outdoors.

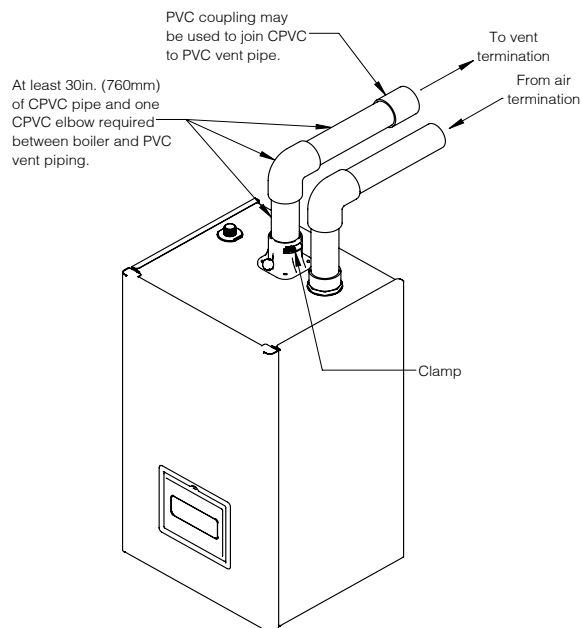

Figure 7-12: Near Boiler CPVC/PVC Venting

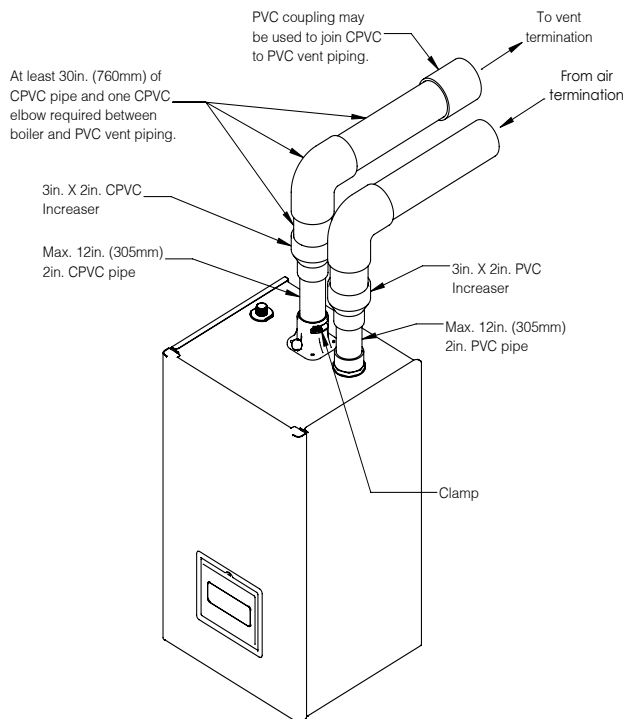

Figure 7-13: Near Boiler CPVC/PVC Venting with Increaser

Note: Length of 2 in. pipe is counted toward 30 in. CPVC requirement.

7 General Venting *(continued)*

Maximum Wall Thickness ("T")	2"* (50mm)	6" (150mm)	12" (305mm)
Minimum air space around pipe ("C")	0"* (0mm)	1" (25mm)	1-3/4" (45mm)

*Wall must be of non-combustible construction

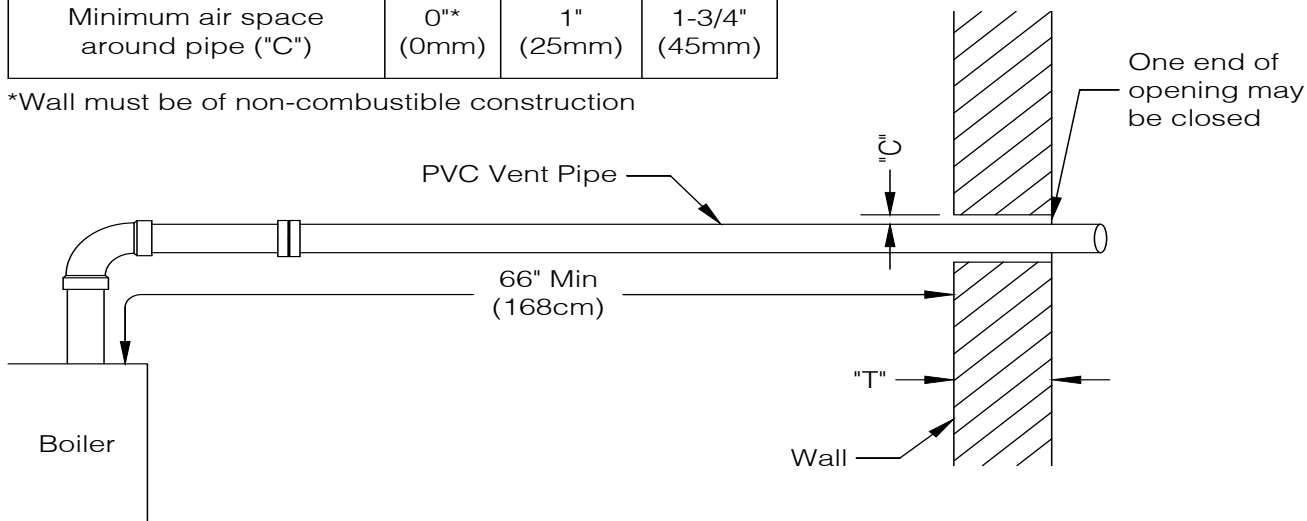
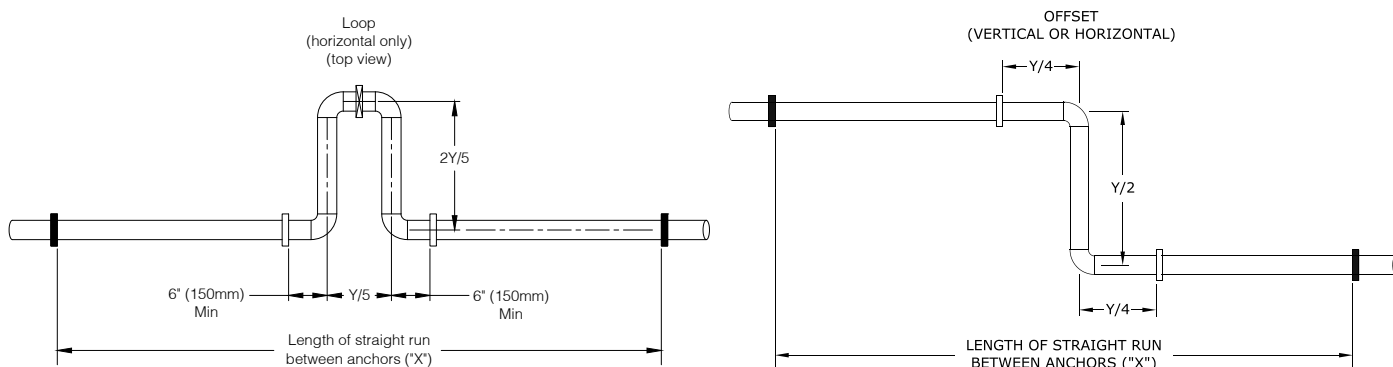
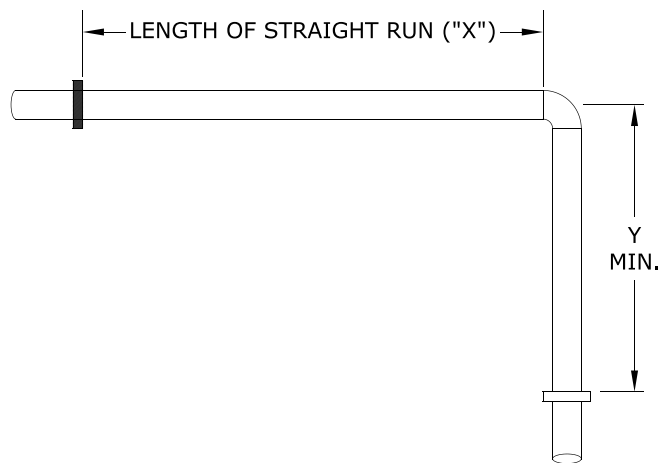

Figure 7-14: PVC Venting Wall Penetration Clearance



**CHANGE OF DIRECTION
(VERTICAL OR HORIZONTAL)**



Pipe Dia., in.	X, ft. (m)	Y, in. (cm)
2	20 (6.1)	41 (104)
	30 (9.1)	50 (127)
	40 (12.2)	58 (147)
	50 (15.2)	65 (165)
	60 (18.3)	71 (180)
3	20 (6.1)	50 (127)
	30 (9.1)	61 (155)
	40 (12.2)	70 (178)
	50 (15.2)	79 (201)
	60 (18.3)	86 (218)

- Key**
- Anchor (restricts linear movement)
 - Hanger (allows linear movement)
 - Can use either anchor or hanger

Figure 7-15: CPVC/PVC Venting Expansion Loops

7 General Venting *(continued)*

Polypropylene Venting

WARNING

Asphyxiation Hazard.

- Use only vent materials listed in Table 7-16 to make vent connections. Consult vent manufacturer's instructions for required support and special connections.
- Follow vent manufacturer's instructions supplied with vent system.
- Do not mix vent systems of different types or manufacturers.
- Maintain clearances to vent piping per Figure 5-1.
- Failure to comply with venting instructions could cause products of combustion and/or carbon monoxide to enter the building, resulting in severe personal injury, death or substantial property damage.

WARNING

Asphyxiation Hazard.

All polypropylene vent systems rely on gaskets for sealing. Ensure gaskets are installed in each female end of vent pipe or fitting. Failure to make proper joint connections could cause products of combustion and/or carbon monoxide to enter the building, resulting in severe personal injury, death or substantial property damage.

NOTICE: Polypropylene vent connections must be secured by vent manufacturer's joint connector.

1. Slope polypropylene vent pipe not less than 5/8 in. per ft. (52 mm per m) upwards from boiler to vent terminal for condensate drainage.
2. Support polypropylene venting per vent manufacturer's instructions.
3. Examine all components for possible shipping damage prior to installation.
4. Work from boiler towards vent or air termination. Do not exceed maximum equivalent lengths shown in Table 7-7. See Table 7-9 for equivalent lengths of elbows and fittings.
5. Only cut polypropylene vent pipe as permitted by vent manufacturer and in accordance with their instructions. Ensure cut end is square and deburred prior to assembly.

Table 7-16: Listed Polypropylene Vent Materials (ULC-S636 Listed)

Manufacturer	Model
DuraVent	Polypropylene Single Wall Rigid
	PolyPro Flex
Centrotherm	InnoFlue Single Wall Rigid
	InnoFlue Flex
Selkirk	PolyFlue Single Wall Rigid
	PolyFlue Single Wall Flex

6. Boiler vent connector is gasketed. Lubricate gasket with soapy water, insert pipe until it bottoms out, and tighten clamp. See Figure 7-18.
7. Assemble remainder of vent system in accordance with vent manufacturer's instruction being sure to provide for thermal expansion. Clamp sections together as directed by vent manufacturer.
8. All air piping may be PVC or polypropylene. PVC to polypropylene adapter required at boiler connection if using polypropylene air piping.
9. Vent and air can be up-sized to 3 in. for longer runs. Requires 2 x 3 in. polypropylene increaser. Vent increaser must be directly attached to boiler vent connector and must be installed in vertical section of pipe. If using polypropylene air piping, increaser must be directly attached to PVC to polypropylene adapter and must be installed in vertical section of pipe. See Figure 7-19.
10. If using flexible polypropylene:
 - A. Maximum length of corrugated flexible venting will be reduced vs. rigid pipe due to higher pressure drop of flexible venting. See Table 7-10.
 - B. Store vent material in ambient space 41°F (5°C) or warmer before beginning installation. Observe vent manufacturer's instructions for storing and handling this pipe.
 - C. Use only in vertical or near vertical installations with bends no greater than 45°. Maximum two offsets (four bends).

7 General Venting *(continued)*

Table 7-17: Listed Polypropylene Vent Fittings

	Length	DuraVent PolyPro	Centrotherm InnoFlue	Selkirk PolyFlue
Joint Connector	2 in. (60 mm)	2PPS-LC	IANS02	PF-LB
	3 in. (80 mm)	3PPS-LC	IANS03	PF-LB or 4PF-LB
Increaser	2 in. (60 mm) to 3 in. (80 mm)	2PPS-X3L	ISIA0203	2PF-2I3 + PF-LB locking band
PVC to PP Adapter	2 in. (60 mm)	2PPS-ADL	ISAGL0202 adapter + IAFC02 clamp	N/A

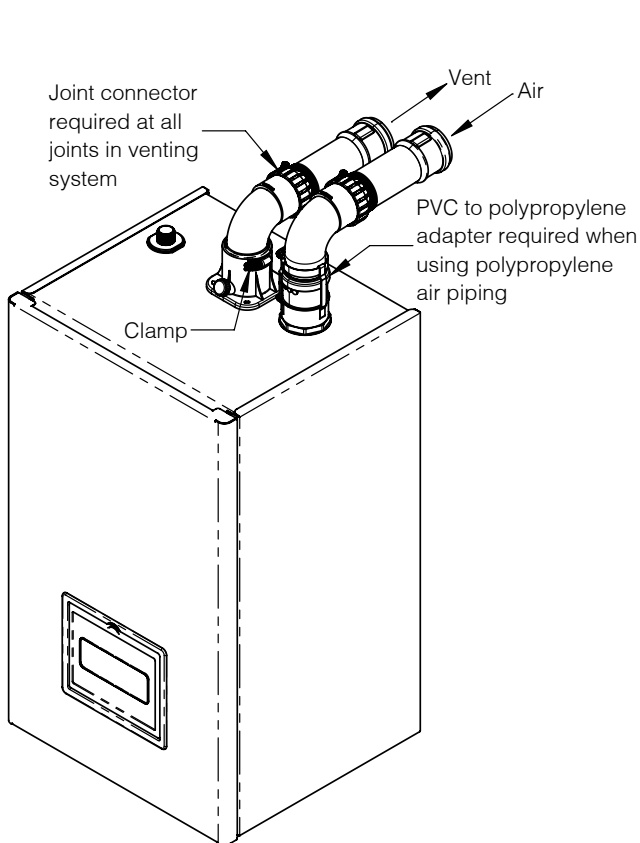

Figure 7-18: Near Boiler Polypropylene Venting

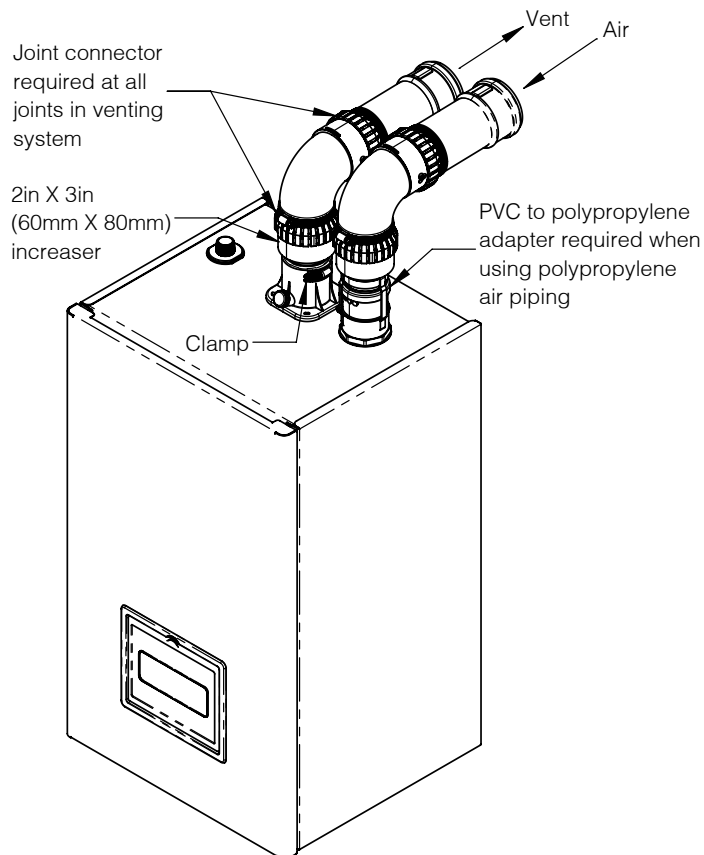

Figure 7-19: Near Boiler Polypropylene Venting with Increaser

8 Sidewall Direct Venting

Determine Terminal Location

WARNING

Asphyxiation Hazard.

- Follow these instructions when determining vent terminal location. Failure to comply could result in severe personal injury, death or substantial property damage.
 - A gas vent extending through an exterior wall shall not terminate adjacent to a wall or below building extensions such as eaves, parapets, balconies, or decks.
1. Do not exceed maximum equivalent vent and air pipe length in Table 7-7.
 2. Consider surroundings when selecting terminal location:
 - A. Locate terminal so flue gas will not damage nearby plants or air conditioning equipment or be objectionable to building owner.
 - B. During cold weather, a visible cloud of flue gases will be emitted from terminal. Avoid areas where this could obstruct window view or be otherwise objectionable.
 - C. Flue gas may condense or freeze causing water or ice buildup on objects surrounding structure. Move or protect these objects if they are subject to damage from condensate.
 - D. Avoid possibility of accidental contact of flue gas with people or pets.
 - E. Avoid locating terminal where wind currents could affect performance or cause recirculation. Areas to avoid include inside building corners, near adjacent buildings or surfaces, windows wells, stairwells, alcoves, courtyards, or other recessed areas.
 3. Locate terminals so they are not likely to be damaged by foreign objects such as stones or balls, or subject to buildup of leaves or dirt.
 4. Maintain clearances to vent terminal per Figure 8-1.
 - A. Minimum 12 in. (305 mm) from any door, window or other gravity air inlet.
 - B. Minimum 3 ft. (900 mm) above any forced air inlet located within 10 ft. (3.1 m).
 - C. Minimum 12 in. (305 mm) from inside corner. 6 ft. (1.8 m) is generally recommended and required when window and/or air inlet is within 4 ft. (1.2 m) of inside corner.
 - D. Do not locate terminal above a public walkway.
 - E. Minimum 12 in. (305 mm) below roof overhang. Close proximity to overhang and/or a deep overhang requires vent terminal to protrude farther from wall.
 - F. Minimum 4 ft. (1.2 m) in USA or 6 ft. (1.8 m) in Canada from any electric meter, gas meter, regulator, or relief equipment. Never terminate above or below any of these within 4 ft. (1.2 m) horizontally.
 - G. Vent and air terminals minimum 12 in. (305 mm) above grade or normal snow line, if applicable.
 5. Do not locate vent terminal under decks or similar structures.
 6. Avoid locating combustion air terminal in an area with or likely to have contaminants. See Table 5-2.

NOTICE: Minimize lengths of piping outside building to reduce risk of condensate freezing in vent pipe causing boiler shutdown.

Prepare Wall Penetrations

1. Use base plate (if applicable) to determine air and vent pipe hole centerline locations.
2. Cut hole for air pipe as close as desired to pipe outside diameter.
3. Cut hole for vent pipe at least 1 in. (25 mm) larger than pipe outside diameter following required clearance per Figure 5-1.
4. Ensure vent wall penetration and methods of securing and sealing around terminal allow for thermal expansion.

8 Sidewall Direct Venting *(continued)*

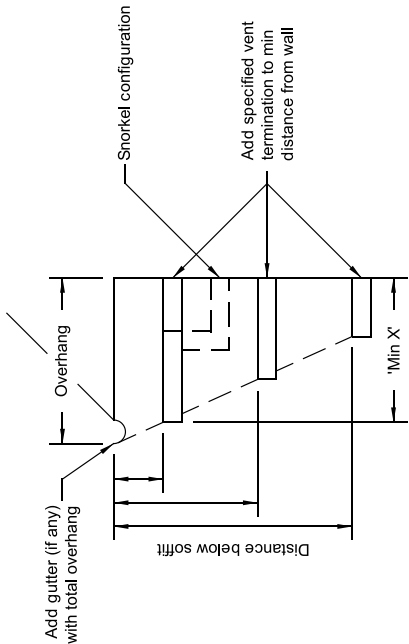

Distance below unventilated soffit	Overhang				
	0-1ft (0-30cm)	1-2ft (30-61cm)	2-3ft (61-91cm)	3-4ft (91-122cm)	Minimum distance from wall X, in (mm)
1-2ft (30-61cm)	12in (305mm)	-	-	-	-
2-3ft (61-91cm)	12in (305mm)	12in (305mm)	-	-	-
3-4ft (91-122cm)	12in (305mm)	12in (305mm)	12in (305mm)	15in (380mm)	-
4-5ft (122-152cm)	12in (305mm)	12in (305mm)	12in (305mm)	12in (305mm)	-
Over 5ft (152cm)	12in (305mm)	12in (305mm)	12in (305mm)	12in (305mm)	12in (305mm)

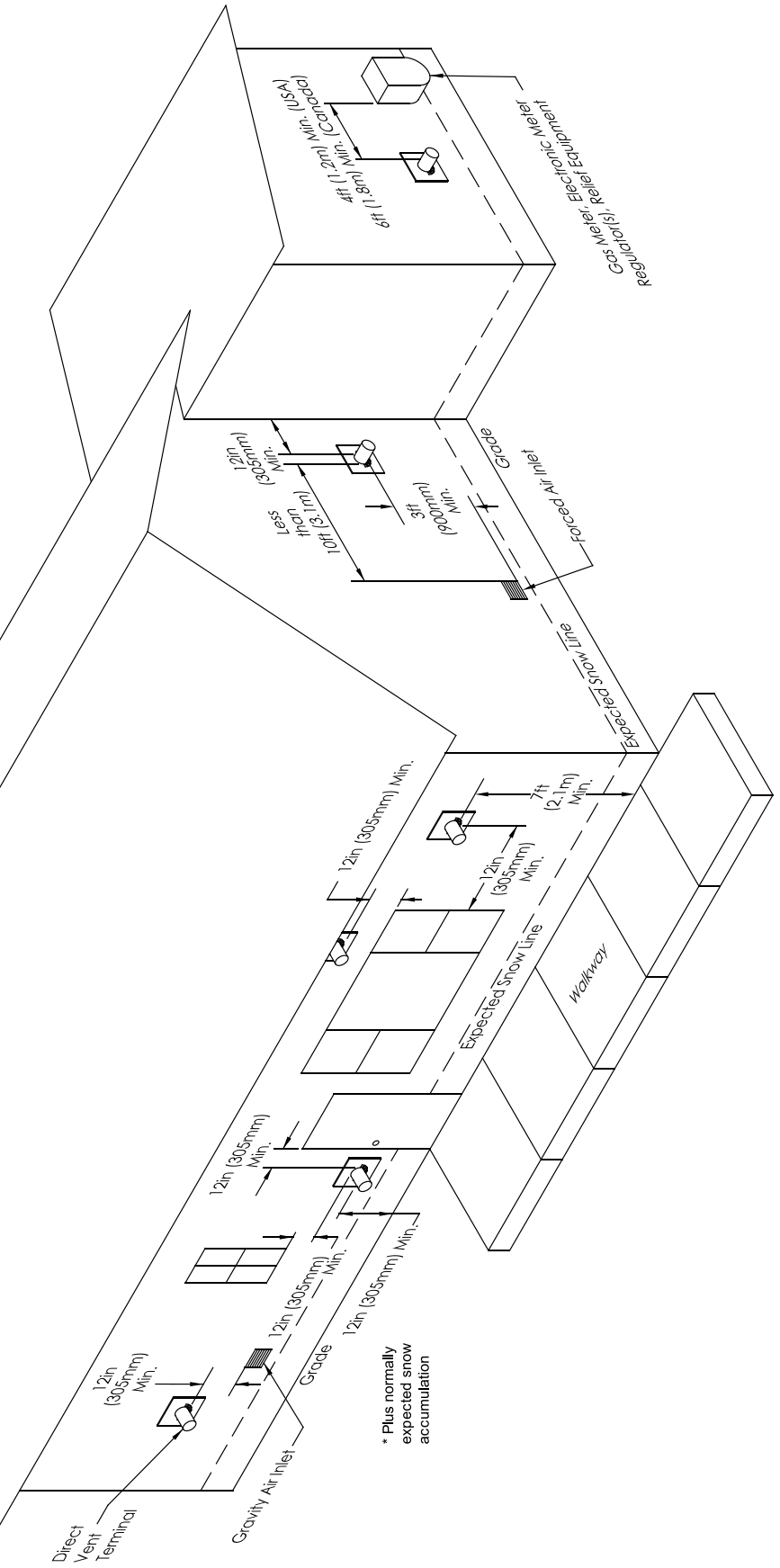

Figure 8-1: Vent Terminal Clearances (Air Terminal not Shown for Clarity)

8 Sidewall Direct Venting *(continued)*

CPVC/PVC or Polypropylene Fittings

Terminal

⚠ WARNING

Asphyxiation Hazard.

All CPVC/PVC vent joints must be glued. Failure to comply could cause products of combustion and/or carbon monoxide to enter the building, resulting in severe personal injury, death or substantial property damage.

⚠ WARNING

Asphyxiation Hazard.

All propylene vent systems rely on gaskets for sealing. Ensure gaskets are installed in each female end of vent pipe or fitting. Failure to make proper joint connections could cause products of combustion and/or carbon monoxide to enter building, resulting in severe personal injury, death or substantial property damage.

1. Vent terminates outside building in elbow, coupling, or end pipe pointing outward away from wall and air terminal. Air terminates outside building in downward-facing elbow. Air terminal may be to left or right of vent terminal. See Figures 8-2 and 8-4.
2. Screens on vent and air intake terminals are generally recommended. Use 1/2 in. (12 mm) mesh stainless steel for CPVC/PVC or listed screens for polypropylene.
3. Vent terminal minimum 12 in. (305 mm) above air terminal.
4. Required CPVC/PVC vent pipe and fittings listed in Table 7-11. Polypropylene listed in Tables 7-16 and 7-17.

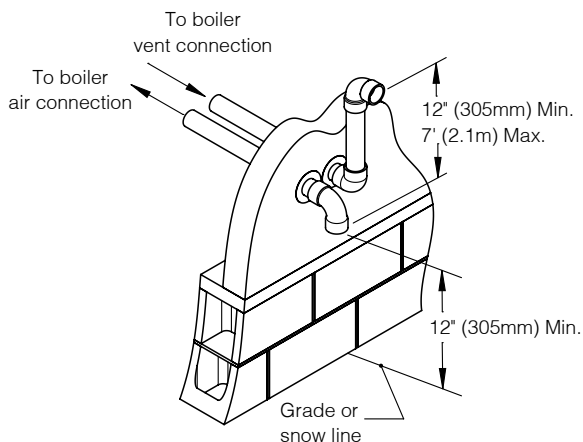

Figure 8-2: Fittings Terminal

Table 8-3: Polypropylene Sidewall Terminal Fittings

DuraVent PolyPro	Centrotherm InnoFlue	Selkirk PolyFlue
UV resistant single wall pipe + two 2PPS-E90BC elbows + 2PPS-BG screen	UV stabilized end pipe + two ISELL0287UV elbows + IASPP02 screen	UV resistant pipe + two 2PF-90UV elbows + 2PF-HVST screen

Note: 2 in. (60 mm) components shown. Replace "2" with "3" for 3 in. (80 mm) component part numbers.

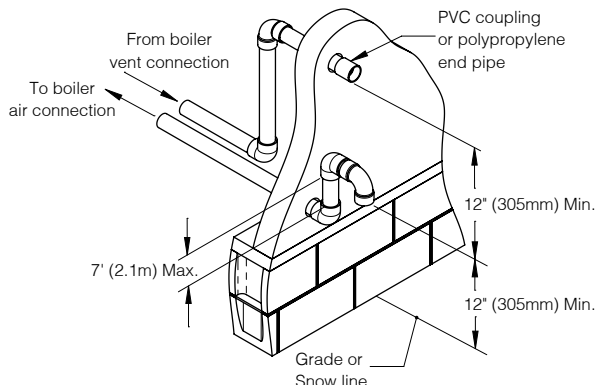

Figure 8-4: Alternate Fittings Terminal

5. Assembly
 - A. Use appropriately sized wall thimble or a sheet metal plate on building exterior to maintain proper clearance and provide weather tight seal.
 - B. If venting with polypropylene:
 - i. Use UV resistant or UV stabilized components for all exterior pipe and fittings.
 - ii. Remove gasket from terminal fitting to install screen.
6. Brace exterior vertical runs of piping as required.
7. Seal exterior openings thoroughly with exterior caulk.

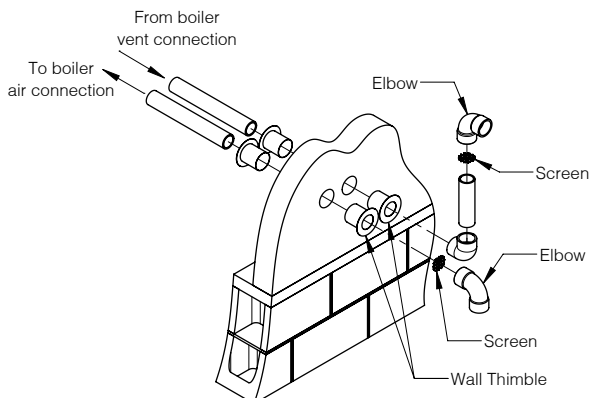

Figure 8-5: CPVC/PVC Fittings Terminal Assembly

8 Sidewall Direct Venting *(continued)*

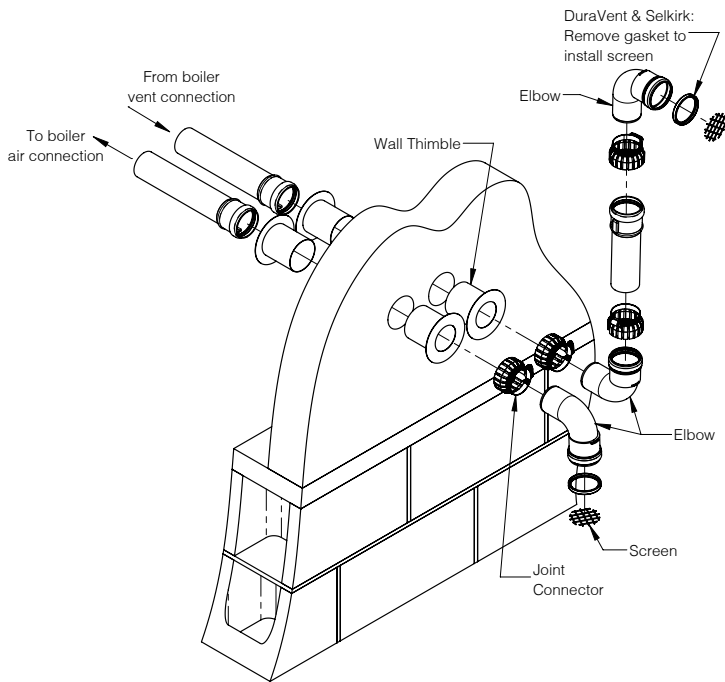

Figure 8-6: Polypropylene Fittings Terminal Assembly

1. Low profile terminals listed in Table 8-7 may be used to terminate air and vent outside building per Figure 8-8. Both air and vent pipes must attach to terminal kit.
2. Required vent pipe and fittings listed in Table 7-11.

Table 8-7: CPVC/PVC Low Profile Terminal Kits

Length	Ipex	Diversitech
2 in. (60 mm)	397984	HVENT-2
3 in. (80 mm)	397985	HVENT-3

3. Follow terminal manufacturer's instructions for assembly.

NOTICE: Ensure outer terminal orientation per Figure 8-8.

⚠ WARNING

Asphyxiation Hazard.

Ensure outer terminal cover is installed before operating boiler. Operation without outer cover installed could cause product damage or improper operation resulting in severe personal injury, death or substantial property damage.

CPVC/PVC Low Profile Terminal

⚠ WARNING

Asphyxiation Hazard.

All CPVC/PVC vent joints must be glued. Failure to comply could cause products of combustion and/or carbon monoxide to enter the building, resulting in severe personal injury, death or substantial property damage.

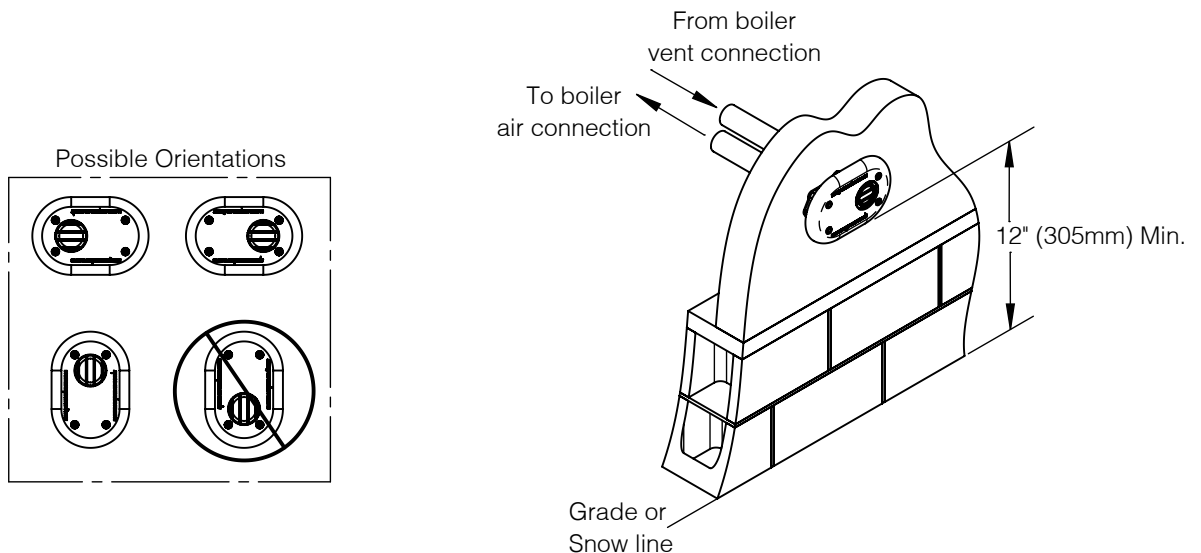

Figure 8-8: Low Profile Terminal

8 Sidewall Direct Venting *(continued)*

CPVC/PVC Concentric Terminal

⚠ WARNING

Asphyxiation Hazard.

All CPVC/PVC vent joints must be glued. Failure to comply could cause products of combustion and/or carbon monoxide to enter the building, resulting in severe personal injury, death or substantial property damage.

1. Concentric vent terminals listed in Table 8-9 may be used to terminate air and vent outside building per Figure 8-10. Both air and vent pipes must attach to terminal kit.

⚠ WARNING

Asphyxiation Hazard.

If vent system is too short to accommodate required 30 in. (760 mm) of CPVC pipe and CPVC elbow between boiler and PVC venting, use listed CPVC terminal kit. Failure to comply could result in severe personal injury, death or substantial property damage.

2. Required vent pipe and fittings listed in Table 7-11.

Table 8-9: CPVC/PVC Concentric Terminal Kits

Length	Iplex	Diversitech
2 in. (60 mm) PVC	397005	CVENT-2
2 in. (60 mm) CPVC	197040	N/A
3 in. (80 mm) PVC	397006	CVENT-3
3 in. (80 mm) CPVC	197009	N/A

Note: Additional Iplex concentric terminal kits with different lengths may also be used.

3. Follow terminal manufacturer's instructions and Figure 8-11 for assembly.
4. If needed, terminal can be shortened. Follow terminal manufacturer's instructions and Figure 8-12.

⚠ WARNING

Asphyxiation Hazard.

- Ensure rain cap is installed before operating boiler. Operation without rain cap installed could cause product damage or improper operation resulting in severe personal injury, death or substantial property damage.
- If using stainless steel screw to attach rain cap, always drill clearance hole in rain cap and pilot hole in vent pipe appropriate for screw size to avoid cracking PVC components. Failure to comply may cause product damage or improper operation, resulting in severe personal injury, death, or substantial property damage.

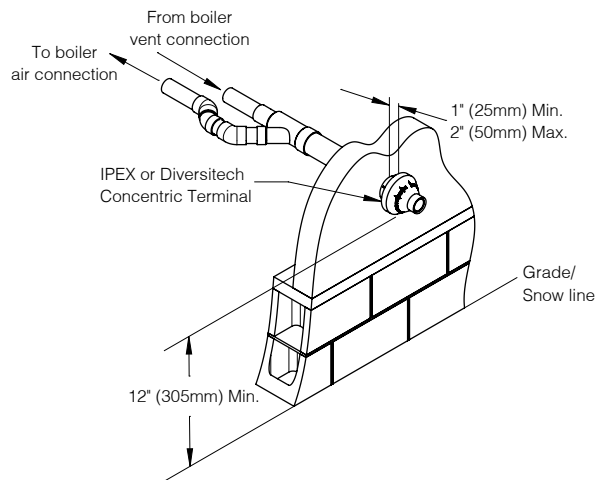

Figure 8-10: CPVC/PVC Concentric Terminal

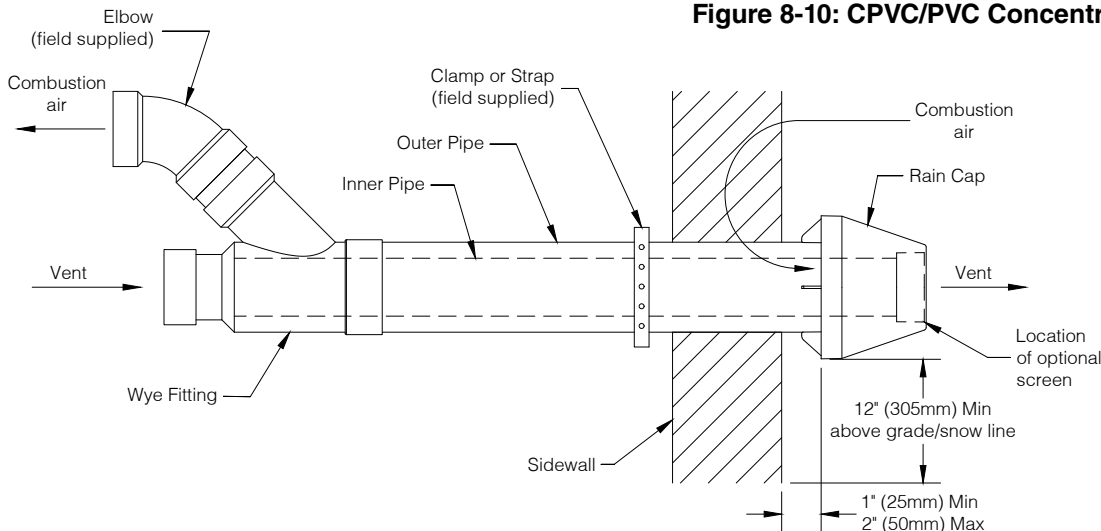
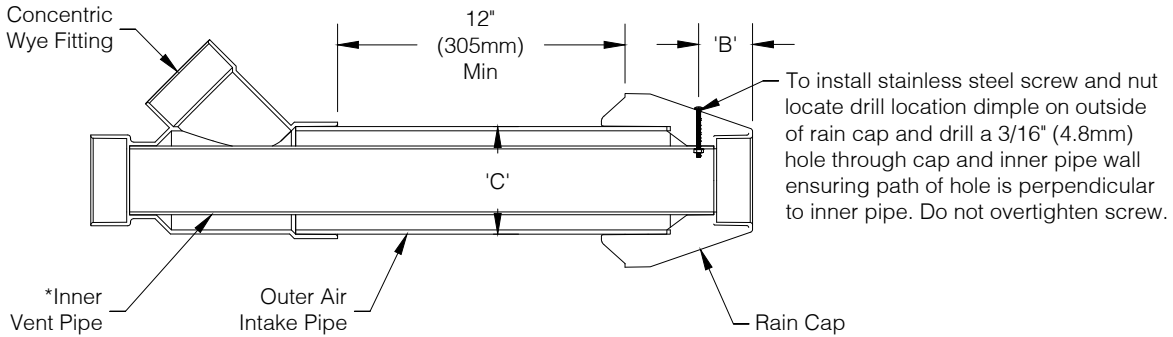

Figure 8-11: CPVC/PVC Concentric Terminal Installation

8 Sidewall Direct Venting *(continued)*

*Overall length of inner pipe to be 'A' longer than overall length of outer pipe.

Kit Size	*'A'	'B'	'C'	Manufacturer
2"	7-3/8" (187mm)	1-3/4" (44mm)	3-1/2" (89mm)	IPEX
	12-3/16" (310mm)	3/4" (19mm)		DIVERSITECH
3"	8-3/4" (222mm)	2-1/4" (57mm)	4-1/2" (114mm)	IPEX
	12-3/16" (310mm)	1" (25mm)		DIVERSITECH



Notes:

1. All cuts must be square and deburred.
2. Lengthening of terminal is not permitted.

Figure 8-12: CPVC/PVC Concentric Terminal Dimensions

Polypropylene Concentric Terminal

WARNING

Asphyxiation Hazard.

All polypropylene vent systems rely on gaskets for sealing. Ensure gaskets are installed in each female end of vent pipe or fitting. Failure to make proper joint connections could cause products of combustion and/or carbon monoxide to enter the building, resulting in severe personal injury, death or substantial property damage.

1. Concentric terminals listed in Table 8-13 may be used to terminate air and vent outside building per Figure 8-14. Both air and vent pipes must attach to terminal kit.

2. Required vent pipe and fittings listed on Tables 7-16 and 7-17.
3. One polypropylene to PVC adapter required. Install at terminal air pipe connection if using PVC air pipe. Install at boiler air connection if using polypropylene air pipe.
4. Follow terminal manufacturer instructions for assembly.

Table 8-13: Polypropylene Concentric Sidewall Terminal Components

Length	DuraVent PolyPro	Centrotherm InnoFlue	Selkirk PolyFlue
2 in. (60 mm)	2PPS-HKC	ICWT242 terminal + ICTCR24 two-pipe adapter	2PF-HCT terminal + 2PF-CTA two-pipe adapter
3 in. (80 mm)	3PPS-HKC	ICWT352 terminal + ICCT3503 two-pipe adapter	3PF-HCT terminal + 3PF-CTA two-pipe adapter

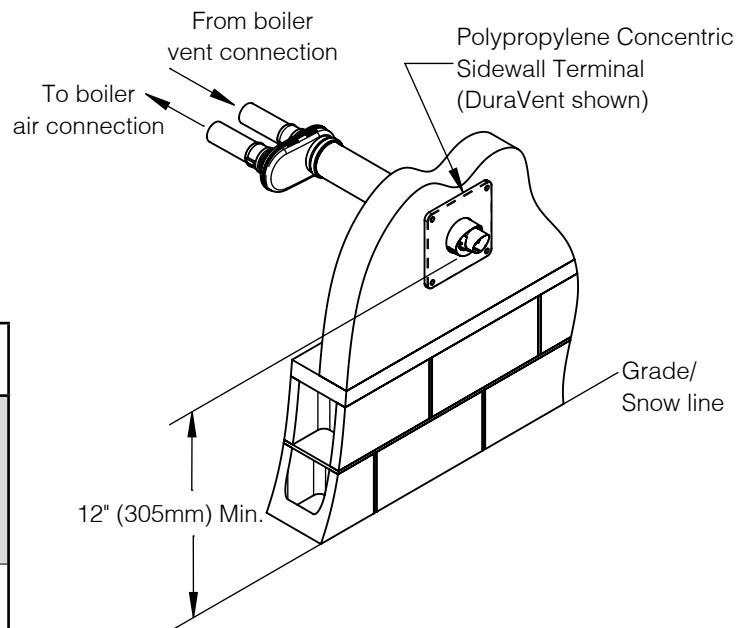

Figure 8-14: Polypropylene Concentric Terminal

9 Vertical Direct Venting

Determine Terminal Location

⚠ WARNING

Asphyxiation Hazard.

Follow these instructions when determining vent terminal location. Failure to comply could result in severe personal injury, death or substantial property damage.

1. Do not exceed maximum equivalent vent and air pipe length in Table 7-7.
2. Vent must terminate at least 2 ft. (610 mm) above any part of the building within 10 ft. (3.1 m) horizontally.
3. Avoid locating combustion air terminal in an area with or likely to have contaminants. See Table 5-2.

NOTICE: Minimize lengths of piping outside building to reduce risk of condensate freezing in vent pipe causing boiler shutdown.

Prepare Roof Penetrations

1. Cut hole for air pipe as close as desired to pipe outside diameter.
2. Cut hole for vent pipe at least 1 in. (25 mm) larger than pipe outside diameter following required clearance per Figure 5-1.
3. Ensure vent roof penetration and methods of securing and sealing around terminal allows for thermal expansion.
4. Use roof flashing and storm collars to ensure a weather tight seal and prevent moisture from entering building.
5. Follow all local codes for isolation of vent pipe and fire stops when passing through floors, ceilings, and roofs.

CPVC/PVC or Polypropylene Fittings Terminal

⚠ WARNING

Asphyxiation Hazard.

All CPVC/PVC vent joints must be glued. Failure to comply could cause products of combustion and/or carbon monoxide to enter the building, resulting in severe personal injury, death or substantial property damage..

⚠ WARNING

Asphyxiation Hazard.

All polypropylene vent systems rely on gaskets for sealing. Ensure gaskets are installed in each female end of vent pipe or fitting. Failure to make proper joint connections could cause products of combustion and/or carbon monoxide to enter the building, resulting in severe personal injury, death or substantial property damage.

1. Vent terminates outside building in coupling or end pipe pointing upward. Air terminates outside building in downward-facing elbow. Use two 90° elbows or 180° bend for air terminal. Air terminal may be to left, right, or below vent terminal as long as clearances in Figure 9-1 are maintained.
2. Screens on vent and air intake terminals are generally recommended. Use 1/2 in. (12 mm) mesh stainless steel for CPVC/PVC or listed screens for polypropylene.
3. Vent terminal minimum 12 in. (305 mm) above air terminal.
4. Required CPVC/PVC vent pipe and fittings listed in Table 7-11. Polypropylene listed in Tables 7-16 and 7-17.
5. Alternate terminal arrangement with vertical vent and sidewall air intake is permitted. See Figure 9-5.

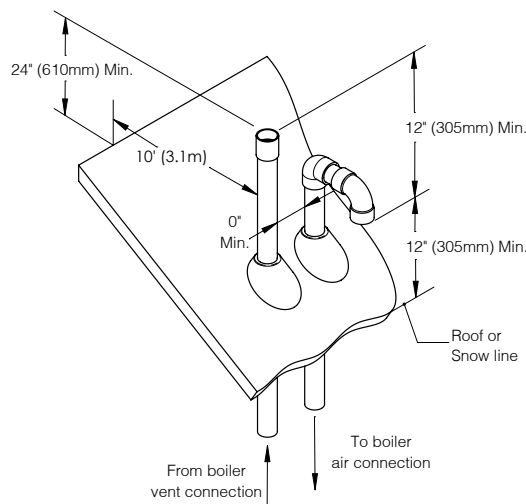

Figure 9-1: Fittings Terminal

9 Vertical Direct Venting *(continued)*

Table 9-2: Polypropylene Vertical Terminal Fittings

DuraVent PolyPro	Centrotherm InnoFlue	Selkirk PolyFlue
UV resistant single wall pipe + 2PPS-BG screen	UV stabilized end pipe + IASPP02 screen	UV resistant pipe + 2PF-HVST screen

Note: 2 in. (60 mm) components shown. Replace "2" with "3" for 3 in. (80 mm) part numbers.

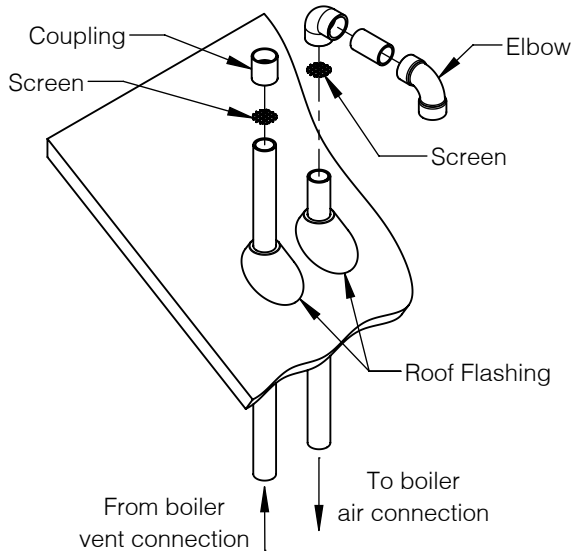

Figure 9-3: CPVC/PVC Fittings Terminal Assembly

6. Assembly

- A. Use appropriately sized roof flashing to maintain proper clearance and provide weather-tight seal.
- B. If venting with polypropylene
 - i. Use UV resistant or UV stabilized components for all exterior pipe and fittings.
 - ii. Remove gasket from terminal fitting to install screen.
- 7. Brace exterior vertical runs of piping as required.

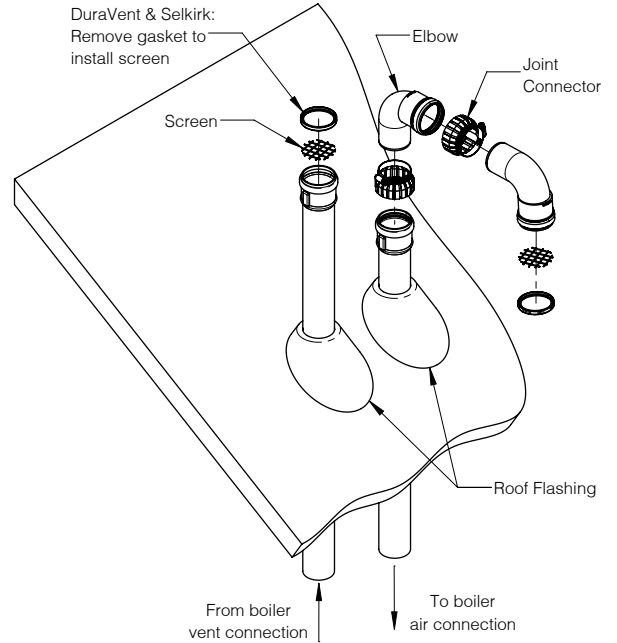

Figure 9-4: Polypropylene Fittings Terminal Assembly

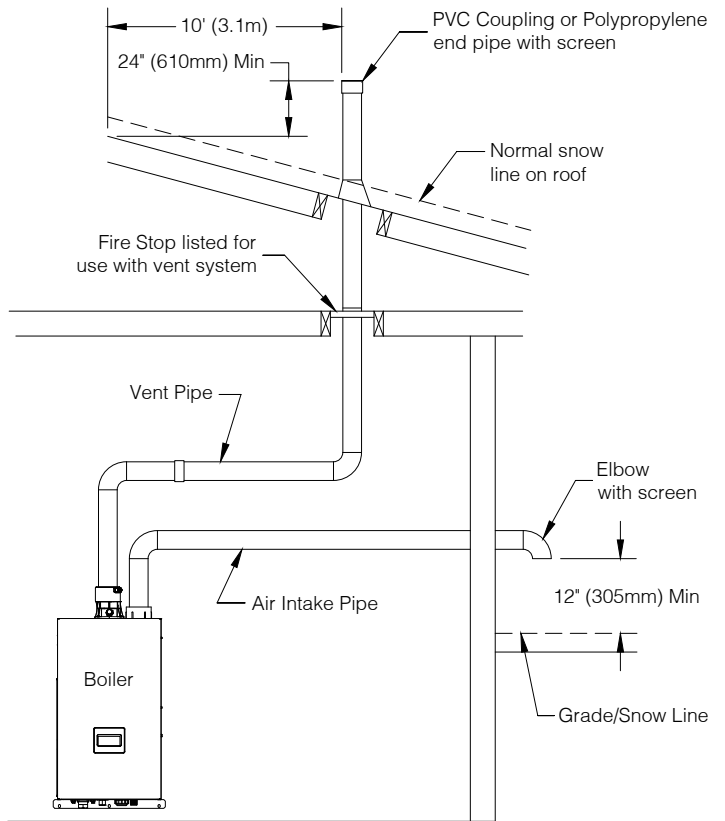

Figure 9-5: Alternate Vertical Vent/Sidewall Air Terminal

9 Vertical Direct Venting *(continued)*

CPVC/PVC Concentric Terminal

⚠ WARNING

Asphyxiation Hazard.

All CPVC/PVC vent joints must be glued. Failure to comply could cause products of combustion and/or carbon monoxide to enter the building, resulting in severe personal injury, death or substantial property damage.

1. Concentric vent terminals listed in Table 8-9 may be used to terminate air and vent outside building per Figure 9-6. Both air and vent pipes must attach to terminal kit.
2. Required vent pipe and fittings listed in Table 7-11.
3. Follow terminal manufacturer's instructions and Figure 9-7 for assembly.

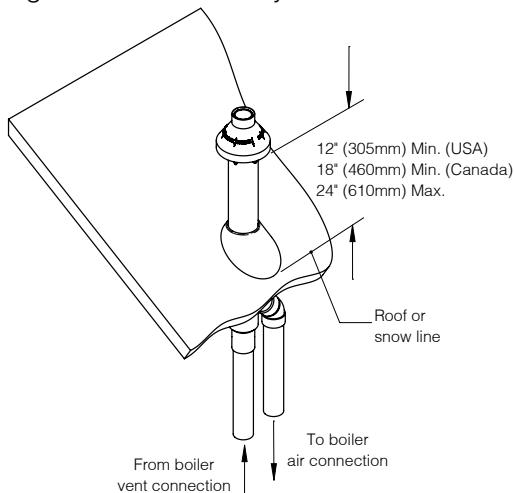

Figure 9-6: CPVC/PVC Concentric Terminal

4. If needed, terminal can be shortened. Follow terminal manufacturer's instructions and Figure 8-12.

⚠ WARNING

Asphyxiation Hazard.

Ensure rain cap is installed before operating boiler. Operation without rain cap installed could cause product damage or improper operation, resulting in severe personal injury, death or substantial property damage.

⚠ WARNING

Asphyxiation Hazard.

If using stainless steel screw to attach rain cap, always drill clearance hole in rain cap and pilot hole in vent pipe appropriate for screw size to avoid cracking PVC components. Failure to comply may cause product damage or improper operation, resulting in substantial property damage, or death.

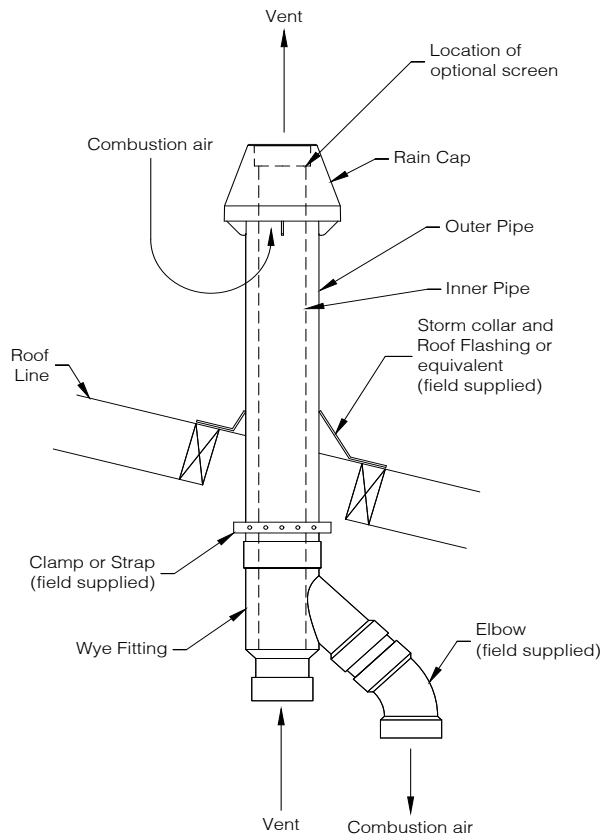

Figure 9-7: CPVC/PVC Concentric Vertical Installation

⚠ WARNING

Do not install U-bend or any other fittings on terminal rain cap. Failure to comply could cause product damage or improper operation, resulting in severe personal injury, death or substantial property damage.

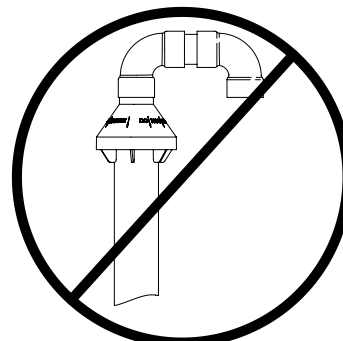

Figure 9-8: Do Not Install U-bend or Any Other Fittings on Terminal Rain Cap

9 Vertical Direct Venting *(continued)*

Polypropylene Concentric Terminal

⚠ WARNING

Asphyxiation Hazard.

All polypropylene vent systems rely on gaskets for sealing. Ensure gaskets are installed in each female end of vent pipe or fitting. Failure to make proper joint connections could cause products of combustion and/or carbon monoxide to enter the building, resulting in severe personal injury, death or substantial property damage.

1. Concentric terminals listed in Table 9-9 may be used to terminate air and vent outside building per Figure 9-10. Both air and vent pipes must attach to terminal kit.
2. Required vent pipe and fittings listed in Tables 7-16 and 7-17.
3. One polypropylene to PVC adapter required. Install at terminal air pipe connection if using PVC air pipe. Install at boiler air connection if using polypropylene air pipe.
4. Follow terminal manufacturer instructions for assembly.

Table 9-9: Polypropylene Concentric Vertical Terminal Components

Length	DuraVent PolyPro	Centrotherm InnoFlue	Selkirk PolyFlue
2 in. (60 mm)	2PPS-VKC (black) or 2PPS-VK-TCC (terracotta)	ICRT2439 terminal + ICTCR24 two-pipe adapter	2PF-VCT terminal + 2PF-CTA two-pipe adapter
3 in. (80 mm)	3PPS-VKC (black) or 3PPS-VK-TCC (terracotta)	ICRT3539 terminal + ICCT3503 two-pipe adapter	3PF-VCT terminal + 3PF-CTA two-pipe adapter

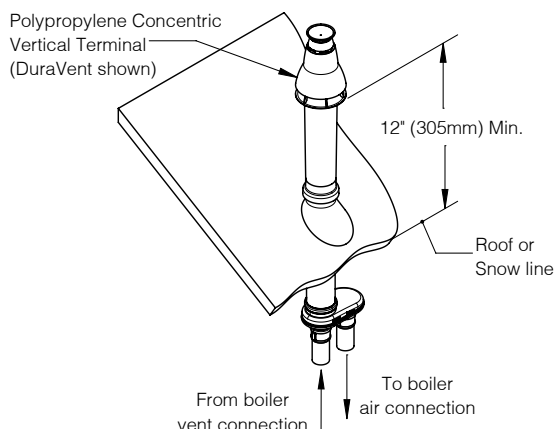

Figure 9-10: Polypropylene Concentric Terminal

Abandoned B-vent Chase

⚠ WARNING

Asphyxiation Hazard.

- Only abandoned (unused) B-vent may be used as a chase. Failure to comply may cause product damage or improper operation resulting in severe personal injury, death or substantial property damage.
- Do not use flexible polypropylene outside of B-vent chimney. Failure to comply may cause product damage or improper operation resulting in severe personal injury, death or substantial property damage.

1. Abandoned B-vent may be used as an air chase with flexible polypropylene vent pipe only if all of the following conditions are met:
 - A. B-vent must be clean and in good condition.
 - B. B-vent inside diameter 6 in. (150 mm) or larger.
 - C. All B-vent joints and seams must be sealed with RTV silicone.

Use DuraVent or Centrotherm concentric terminal and flexible polypropylene listed in Table 9-11 to terminate air and vent outside building per Figure 9-12 and 9-13.

NOTICE: Selkirk components may only be used with a sidewall air termination.

2. If any of above conditions is not met, terminate air piping through sidewall using PVC or polypropylene fittings per Figure 9-14.
3. Required vent pipe and fittings listed in Tables 7-16 and 7-17.
4. Do not count concentric termination when calculating equivalent length.
5. Follow terminal manufacturer instructions for assembly.
6. Air connection for B-vent air chase:
 - A. Install tee same size as B-vent on base of B-vent with cap in side of tee. Connect PVC air pipe to side of tee using a PVC socket x male thread adapter. Cut clearance hole in cap, insert PVC adapter, and install electrical conduit locknut to secure. Seal all joints with RTV silicone.
 - B. DuraVent: Install PolyPro lower B-vent adapter in base of tee.
 - C. Centrotherm: Install cap in base of tee. Route smooth section of InnoFlue flex through cap in base of tee. Use wall plate and RTV silicone to seal this penetration.

9 Vertical Direct Venting *(continued)*

Table 9-11: Polypropylene B-vent Chase Components

DuraVent PolyPro	Centrotherm InnoFlue	Selkirk PolyFlue
2PPS-VFTC flex termination cap + 2PPS-BV* adapter + 2PPS-FLEX** flex length	IFBK02** B-vent kit + IAWP02BP wall plate	2PF-10UV or 2PF-39UV rigid pipe + 2PF-HVST screen + 2PF-FLEX flex length + 2PF-BVSC storm collar

* Size of B-vent (in.), e.g. 2PPS-BV6 for 6 in. B-vent
 ** Length (25, 35, or 50 ft.) e.g. 2PPS-FLEX25 for 25 ft. length
 Note: 2 in. (60 mm) components shown. Replace "2" with "3" for 3 in. (80 mm) part numbers.

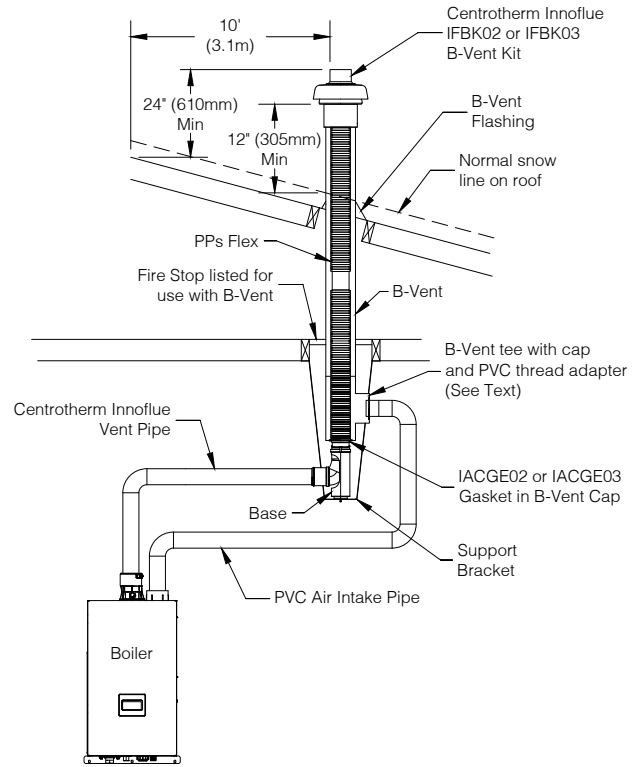

Figure 9-13: Centrotherm Polypropylene B-vent Air Chase System

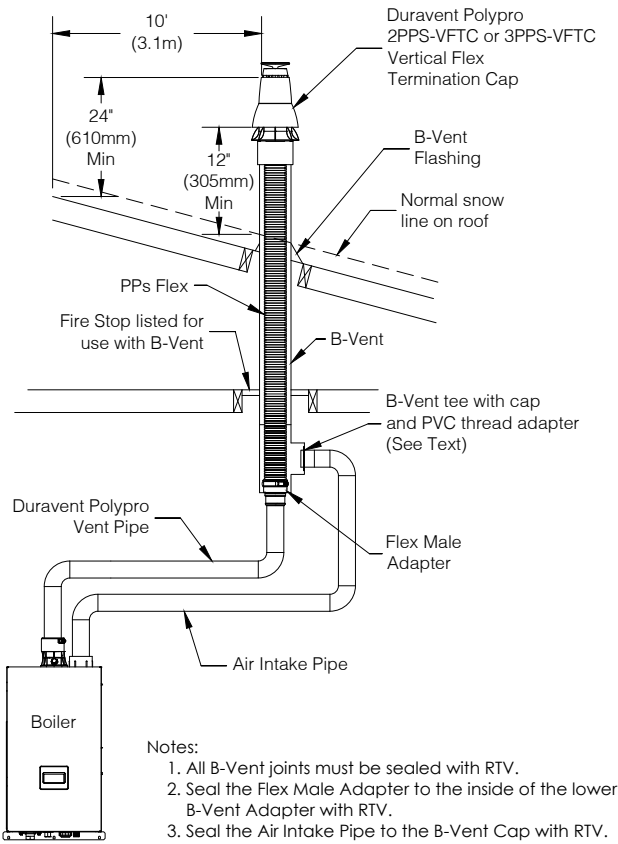

Figure 9-12: DuraVent Polypropylene B-vent Air Chase System

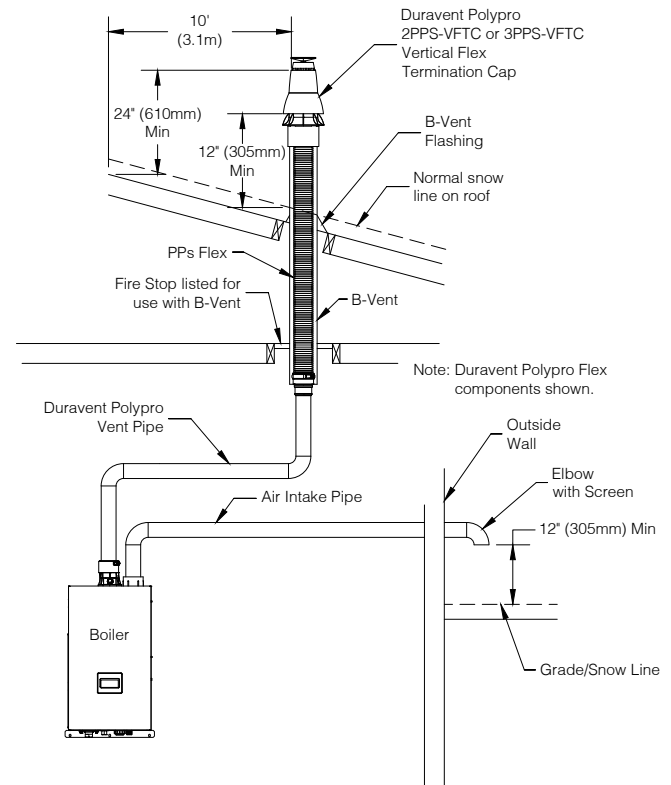

Figure 9-14: Polypropylene B-vent Chase with Sidewall Air Terminal

9 Vertical Direct Venting *(continued)*

Abandoned Chimney Chase

WARNING

Asphyxiation Hazard.

Only abandoned (unused) masonry chimney may be used as a chase. If chimney contains multiple flues, all flues must be abandoned. Failure to comply could cause product damage or improper operation resulting in severe personal injury, death or substantial property damage.

WARNING

Asphyxiation Hazard.

Do not use flexible polypropylene outside of masonry chimney. Failure to comply could cause product damage or improper operation resulting in severe personal injury, death or substantial property damage.

1. Abandoned chimney may be used as a chase with flexible polypropylene vent pipe only if all of the following conditions are met:
 - A. Chimney is structurally sound and in good condition.
 - B. No other appliances or fireplaces are vented into chimney or adjacent flues.

Use concentric terminal and flexible polypropylene listed in Table 9-15 to terminate vent outside building. Terminate air through sidewall using PVC or polypropylene fittings. See Figure 9-16.

2. Follow vent system manufacturer's instructions for assembly.

Table 9-15: Polypropylene Masonry Chimney Chase Components

DuraVent PolyPro	Centrotherm InnoFlue	Selkirk PolyFlue
2PPS-FKC chimney kit + 2PPS-FLEX* flex length	IFCK02* chimney kit with flex length	2PF-FLEX-KIT chimney kit + 2PF-FLEX length

* Length (25, 35, or 50 ft.), e.g. 2PPS-FLEX25 for 25 ft. length

Note: 2 in. (60 mm) components shown. Replace "2" with "3" for 3 in. (80 mm) part numbers.

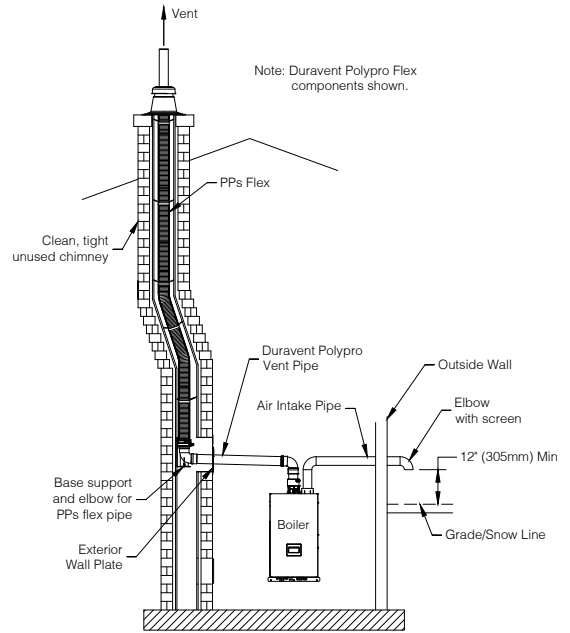

Figure 9-16: Masonry Chimney Chase System

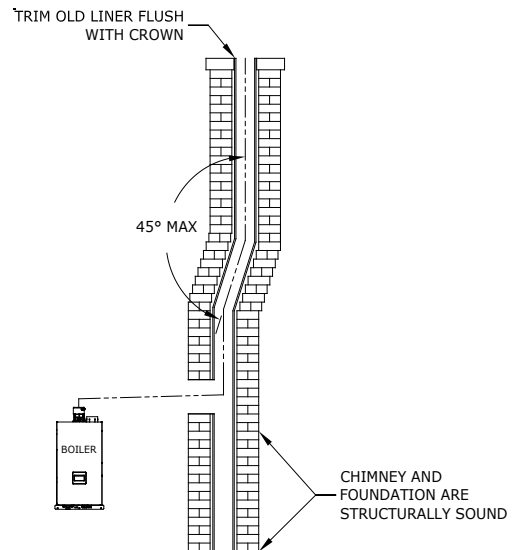

Figure 9-17: Masonry Chimney Chase Requirements

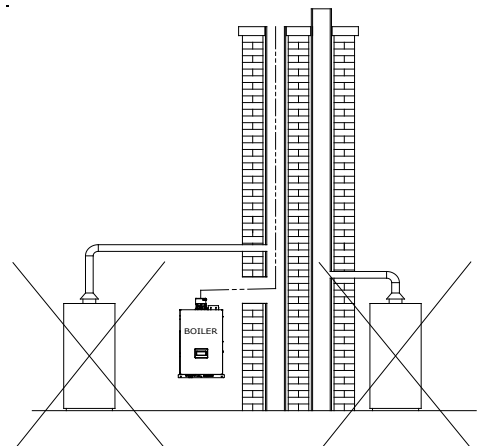

Figure 9-18: Masonry Chimney Chase and Any Adjacent Flues must be Abandoned

10 Heating System Piping

General System Piping Precautions

WARNING

Asphyxiation Hazard.

- Failure to properly pipe boiler could cause improper operation and damage to boiler or building resulting in severe personal injury, death or substantial property damage.
- Protect gas ignition system components from water (dripping, spraying, rain, etc.) during boiler operation and service (circulator replacement, condensate trap cleaning, control replacement etc).
- Oxygen contamination of boiler water will cause corrosion of iron and steel boiler components and could lead to premature boiler failure. Warranty does not cover problems caused by oxygen contamination of boiler water or scale (lime) build-up caused by frequent addition of water.
- Maintain clearances to system piping per Figure 5-1.

CAUTION

Toxic Material.

The heat transfer medium must be water or other nontoxic fluid having a toxicity rating or Class of 1, as listed in *Clinical Toxicology of Commercial Products*, 5th edition.

Standard Piping Components

1. Safety relief valve (required).
 - A. Shipped loose in parts carton (30 psig [207 kPa]).
 - B. Pipe outlet of safety relief valve to location where water or steam will not create a hazard or cause property damage if valve opens. (The end of discharge pipe must terminate in unthreaded pipe.)
 - C. If safety relief valve discharge is not piped to drain, it must terminate within 6 in. (150 mm) of floor.
 - D. Do not route discharge piping through an area that is prone to freezing temperature.
 - E. Termination of safety relief valve must be in an area where it is not likely to become plugged by debris.
- F. If replaced, replacement must have a setting less than or equal to maximum allowable working pressure (MAWP) shown on ASME data plate located on left side of heat exchanger (50 psig [345 kPa]).

WARNING

Burn Hazard.

Safety relief valve discharge piping must be piped near floor to eliminate potential of severe burns. Do not pipe in any shut-off valves between:

1. Safety relief valve and boiler.
 2. Safety relief valve and discharge.
- Union may be installed in safety relief valve piping.

2. Pump (required)

Boiler loop pump is factory installed inside boiler cabinet. At least one additional pump is required on system side.

3. Expansion tank (required)

- A. If this boiler is replacing an existing boiler with no other changes in system, old expansion tank can generally be reused.
- B. If expansion tank must be replaced, consult expansion tank manufacturer's literature for proper sizing.
- C. If using antifreeze, account for additional expansion of glycol solution when sizing an expansion tank. In a typical residential heating system, a glycol mixture has an expansion rate of 1.2 times that of water alone, therefore a tank for an anti-freeze system should be at least 1.2 times greater in size. Antifreeze should be stainless steel compatible.

4. Fill valve (required)

- A. Either a manual or automatic fill valve may be used, but a manual valve is preferred because it eliminates unmonitored additions of make-up water to the system.
- B. Ideal location for fill valve is at expansion tank.
- C. If using antifreeze with automatic fill valve, it is recommended to install a water meter to monitor make-up water. Antifreeze concentration will decrease as make-up water is added. If using antifreeze, local codes often require a backflow preventer or disconnect from city water.

10 Heating System Piping *(continued)*

5. Automatic air vent (required)
 - A. Factory installed manual air vent is included on boiler heat exchanger, to vent heat exchanger. A system air vent is also required.
 - B. Manual air vents will usually be required in other parts of the system to remove air during initial fill.
6. Manual reset high limit (required by some codes i.e. ASME CSD-1)
 - A. Install high limit in boiler supply piping just above boiler with no intervening valves.
 - B. Set manual reset high limit to 200°F. Wire limit to "external limit" terminal on low voltage connection board per Section 13 Field Wiring.
7. Isolation valves are useful when boiler must be drained, as they will eliminate having to drain and refill entire system.
8. Dirt and magnetic filter (strongly recommended)
 - A. Install a dirt/magnetic filter to prevent any system debris from entering boiler and fouling of water passages.
 - B. Note that some filters have a significant pressure drop, which may impact ability of system pump to obtain required flow.
9. Drain valve (required)

Install drain valve as shown in Figure 10-2.
10. Low water cut-off (LWCO) (may be required by local jurisdiction)
 - A. Protection of this boiler against low water and/or inadequate flow is provided by UL353 listed flow switch built into boiler.
 - B. This is a water tube boiler and this flow switch is therefore only effective way to provide such protection.
 - C. Section HG614(c) of ASME Boiler and Pressure Vessel Code recognizes use of a listed flow switch in lieu of LWCO on water tube boilers.
 - D. In event a local jurisdiction insists upon installation of LWCO with this boiler, refer to Section 13 Field Wiring and LWCO manufacturer's instructions for proper wiring.
 - Auto reset LWCO: 105591-01
 - Manual reset LWCO: 108182-01
 - E. Install LWCO in supply piping at point prescribed by the local jurisdiction (generally at a point above boiler, in common header piping).
 - F. If probe type LWCO is used, be certain that it is located at a point in piping from which air can escape to an automatic air vent.
 - G. Generally, this means there should be no down-turns in piping between LWCO and point where automatic air vent is installed.
 - H. Failure to do this may result in nuisance boiler shut-downs due to small amounts of air trapped around probe.

NOTICE: Installing LWCO at top of boiler in relief valve location may cause nuisance shut-downs.

11. Low Loss Header (supplied with this boiler) provides instant primary-secondary connection.

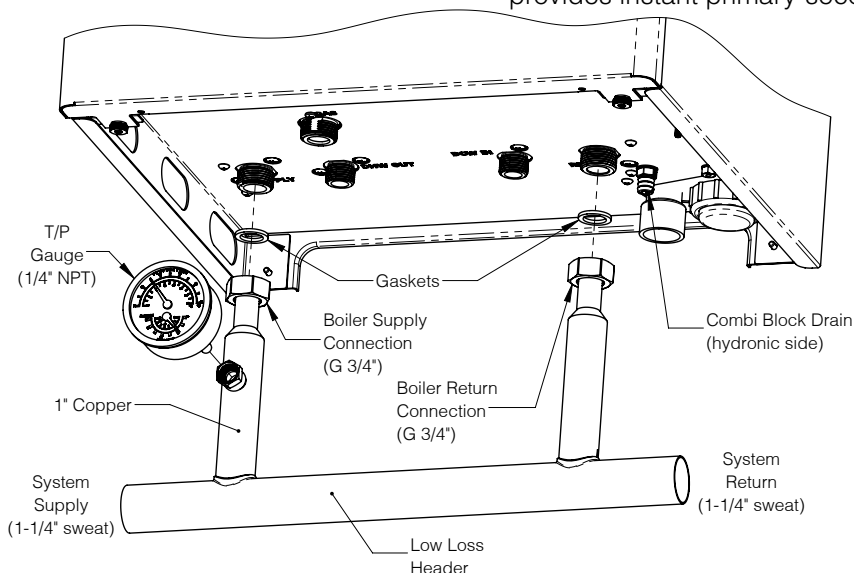
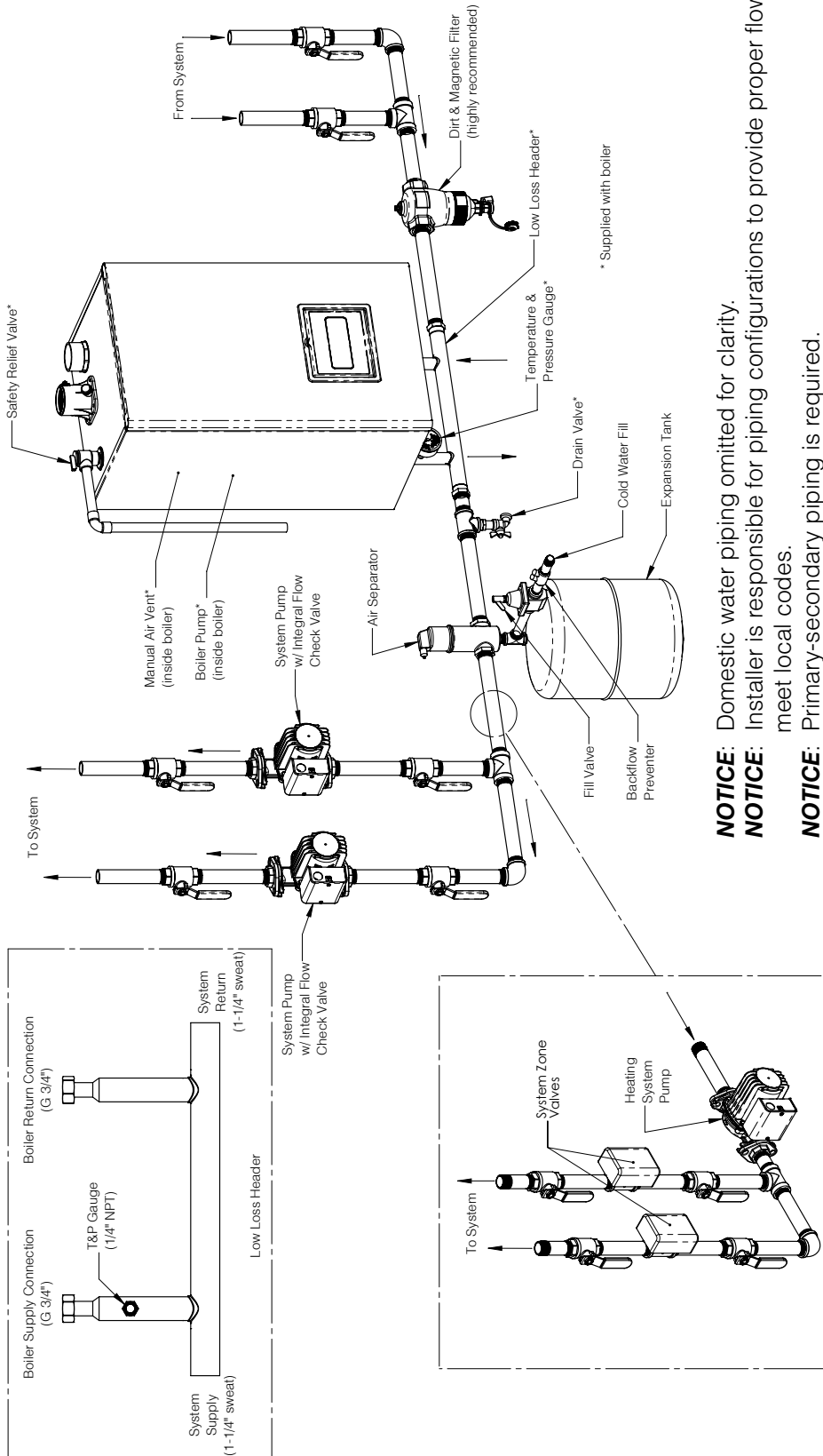

Figure 10-1: Low Loss Header Connections

10 Heating System Piping (continued)



NOTICE: Domestic water piping omitted for clarity.
NOTICE: Installer is responsible for piping configurations to provide proper flow rates and meet local codes.
NOTICE: Primary-secondary piping is required.

CAUTION

Burn Hazard. Property Damage.

Under some conditions this boiler can deliver water to heating system that is significantly higher than boiler setpoint. Where such overheat could cause personal injury or property damage (e.g. low temperature radiant floor zones), protect system from excessive temperatures using tempering valves or other means.

CAUTION

Component Damage.

Excessive heat from soldering could damage gaskets at connection between low loss header and boiler. Solder connections to low loss header before installing gaskets.

Figure 10-2: Heating System Piping

11 Domestic Water Piping

⚠ DANGER

Scald Hazard.

- Under certain conditions this boiler can deliver domestic hot water (DHW) at temperatures in excess of DHW set point on boiler control. A field supplied ASSE 1017 or ASSE 1070 certified tempering valve is therefore **REQUIRED** as part of this boiler's installation.

- Select and install tempering valve in accordance with valve manufacturer's instructions and applicable local codes. In absence of such codes follow Uniform Plumbing Code (IAPMO/UPC-1). Also note additional tempering valves may be required at fixtures themselves.

NOTICE: DHW feature on this boiler is designed to only heat potable water (i.e. water from a well or water utility that is suitable for drinking) having following characteristics:

- Hardness less than 12 grains/gallons
- pH between 6 and 8
- Chlorides less than 80 PPM

Use of water not having these characteristics could result in premature failure of DHW handling components in this boiler and is not covered under warranty. If there is reason to believe water is contaminated in any way, discontinue use of domestic hot water and contact a qualified, licensed water treatment professional.

⚠ CAUTION

Component Damage.

- Internal components near Hot and Cold connections can be damaged by excessive heat during soldering. Use precautions to limit heat exposure.
- Failure to do so could cause internal leaks resulting in damage to boiler.

Combi connections are 1/2 in. adapters to 3/4 in. sweat connection are provided in parts carton (Figure 11-1).

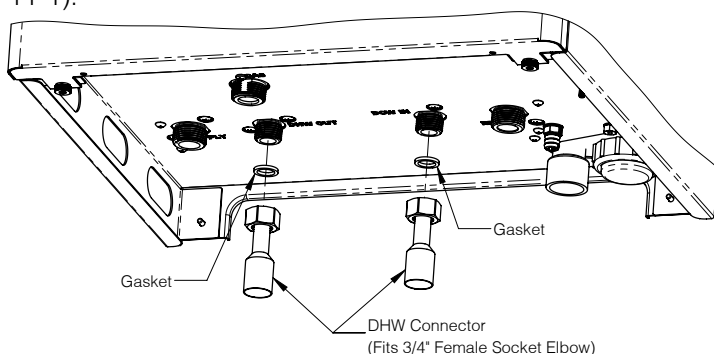

Figure 11-1: DHW Connections

NOTICE: Elbows pointed toward back of boiler are recommended to start DHW piping.

DHW components in this system and their functions are as follows:

1. ASSE 1070 or ASSE 1017 listed tempering valve (required)
Low draw rates and transitions from heating to DHW are two examples of conditions that can cause temperature of water leaving boiler to significantly exceed DHW set point. A tempering valve is required to minimize spikes in DHW temperature. Select and install in accordance with valve manufacturer's instructions and applicable codes.
2. Flow limiter
If DHW draw rate is in excess of rating in Table 3-1, temperature of hot water may be too low for comfortable use. Internal, 6 GPM (23 L/min), flow limiter is factory installed, but an additional flow limiter may be required. Select one having a flow rating approximately equal to that shown in Table 3-1 at desired temperature rise.
3. DHW pressure relief valve (required)
Limits pressure in DHW piping. Use a valve designed for DHW service such as Watts #3L or #53L. Select a valve with a pressure setting less than or equal to 145 psig (1,000 kPa). Pipe discharge to safe location using same size as discharge connection to valve.
4. Drain valve
Permits plate heat exchanger to be periodically back flushed to remove sediment.
5. Globe or ball valves
Used to isolate DHW piping during back flushing and other servicing. In addition, valve may be used to limit DHW flow if necessary.
6. Expansion tank
If back flow preventer or check valve is installed upstream of cold connection, thermal expansion tank will prevent build-up of pressure in DHW piping. Use an expansion tank designed for potable water service.
7. Water filter (highly recommended)
Install Aqua Pure AP430SS or equivalent on potable cold water supply to prevent scale.
8. Buffer tank (Optional)
When recirculation line is installed as shown in Figure 11-3, a small (2-6 gal) potable water storage tank may be installed as shown. Reduces burner cycling during very small DHW demands and also helps minimize temperature fluctuations. An unpowered storage electric water heater is ideal for this application.

11 Domestic Water Piping (continued)

NOTICE: Heating System piping omitted for clarity.
NOTICE: Installer is responsible for piping configurations to provide proper flow rates and meet local codes.

⚠ DANGER

Scald Hazard. Under certain conditions this boiler can deliver domestic hot water (DHW) at temperatures in excess of DHW setpoint in boiler control. A field supplied ASSE 1017 or ASSE 1070 listed tempering valve is required as part of this boiler's installation.

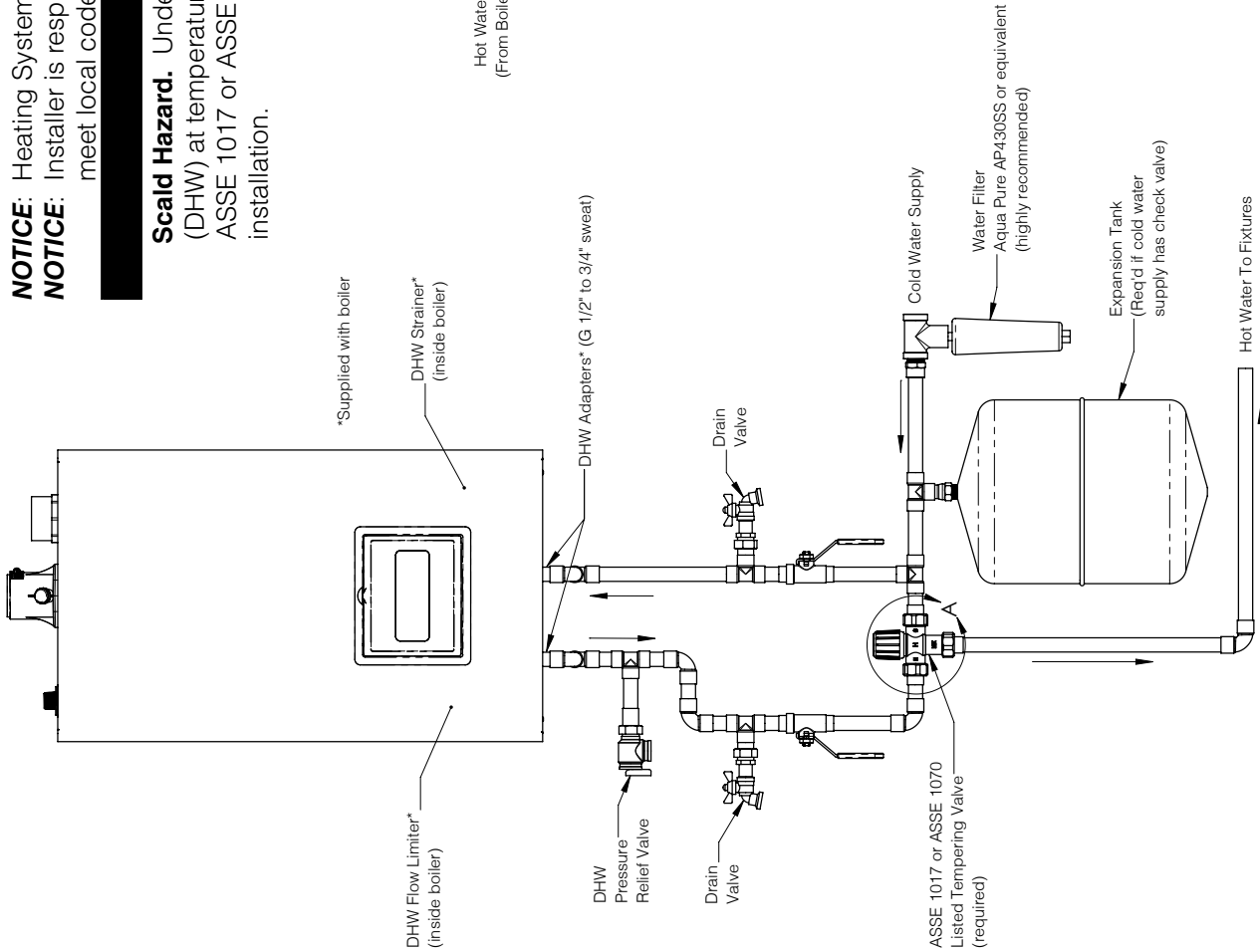

⚠ CAUTION

Component and Property Damage.

- Excessive heat from soldering could damage gaskets at connection between DHW adapters and boiler. Solder connections to DHW adapters before installing gaskets.
- DHW pressure relief valve (and when appropriate-expansion tank) required to protect internal boiler components. Failure to address these items could result in component failure and property damage.

NOTICE: Water filter to prevent scale is strongly recommended on the potable cold water supply line to minimize sediment build up and loss of performance of the plate heat exchanger.

Figure 11-2: Standard DHW Piping

11 Domestic Water Piping *(continued)*

NOTICE: Heating System piping omitted for clarity.
NOTICE: Installer is responsible for piping configurations to provide proper flow rates and meet local codes.



Scald Hazard. Under certain conditions this boiler can deliver domestic hot water (DHW) at temperatures in excess of DHW setpoint in boiler control. A field supplied ASSE 1070 listed anti-scald valve is required as part of this boiler's installation when DHW recirculation is issued.



Component and Property Damage.

- Excessive heat from soldering could damage gaskets at connection between DHW adapters and boiler. Solder connections to DHW adapters before installing gaskets.
- DHW pressure relief valve (and when appropriate-expansion tank) required to protect internal boiler components. Failure to address these items could result in component failure and property damage.

NOTICE: Additional wiring and control settings required for DHW recirculation:

- Connect recirculation pump to "Aux Pump" terminals per Figure 13-2.
- Connect jumper, time of day clock or momentary push button to "Aux T'Stat" terminals per Figure 13-3.
- Secure recirculation temp sensor close to boiler on cold water line.
- Connect recirculation temperature sensor to "Header Sensor" terminals per Figure 13-3.
- Change **FD2** Recirc (Comfort) Mode to 'ON' See Table 16-11.
- Change **FD5** (Auxiliary Thermostat Input Select) to '0' (Recirculation Enable). See Table 16-13.
- Change **FD3** (Auxiliary Pump Output Select) to '1' (Recirculation Pump) See Table 16-15.

NOTICE: Water filter to prevent scale is strongly recommended on the potable cold water supply line to minimize sediment build up and loss of performance of the plate heat exchanger.

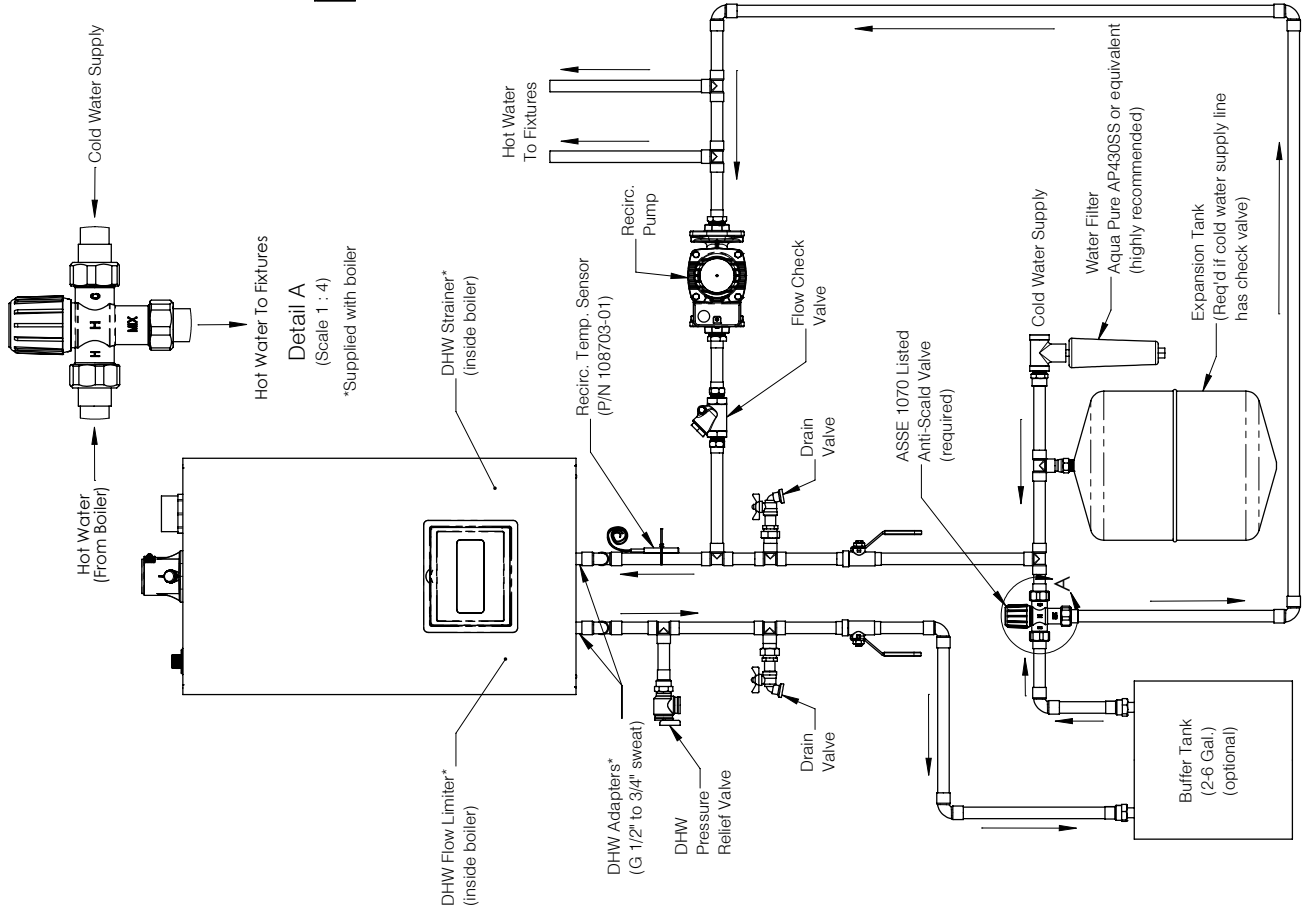

Figure 11-3: DHW Piping with Recirculation

12 Gas Piping

⚠ WARNING

Explosion Hazard.

- Failure to properly pipe gas supply to boiler could cause improper operation or leaks of flammable gas resulting in severe personal injury, death or substantial property damage.
- Gas supply to boiler and system must be shut off prior to installing or servicing boiler gas piping.

1. Gas piping must be sized to deliver adequate gas for boiler operation. Consider the following:
 - A. If gas pressure in building is above 1/2 psig (3.4 kPa), an additional gas pressure regulator is required. If additional regulator is used to reduce boiler inlet pressure, it must be at least 6 to 10 ft. (1.8 to 3.0 m) upstream of boiler.
 - B. Pressure drop from point of delivery to boiler. See Table 3-5 for inlet gas pressure requirements.
 - C. Existing and expected future gas using equipment (i.e. water heater, cooking equipment, etc.).
2. Use methods and materials in accordance with local plumbing codes. In absence of such requirements, follow NFPA 54/ANSI Z223.1 *National Fuel Gas Code* and/or CAN/CSA B149.1 *Natural Gas and Propane Installation code*. Figure 12-1 shows typical gas piping and connection to boiler.
 - A. Use thread compound compatible with liquefied petroleum gas.
 - B. A sediment trap must be installed upstream of gas controls.
 - C. A manual shut-off valve (provided in parts carton) must be installed within 6 ft. (1.8 m) of boiler.
 - D. Support weight of gas piping independently from boiler gas connection.
3. Boiler and its gas connection must be leak tested before placing boiler in operation.
 - A. For pressure testing at equal to or less than 1/2 psig (3.4 kPa) close manual shut-off valve.
 - B. For pressure testing above 1/2 psig (3.4 kPa) disconnect boiler and manual shut-off valve.

⚠ DANGER

Explosion Hazard.

Do not use matches, candles, open flames or other ignition sources to check for leaks. Failure to comply could result in severe personal injury, death or substantial property damage.

- C. Locate leaks using listed combustible gas detector, a non-corrosive leak detection fluid or other listed leak detection method. Repair any leaks found immediately.

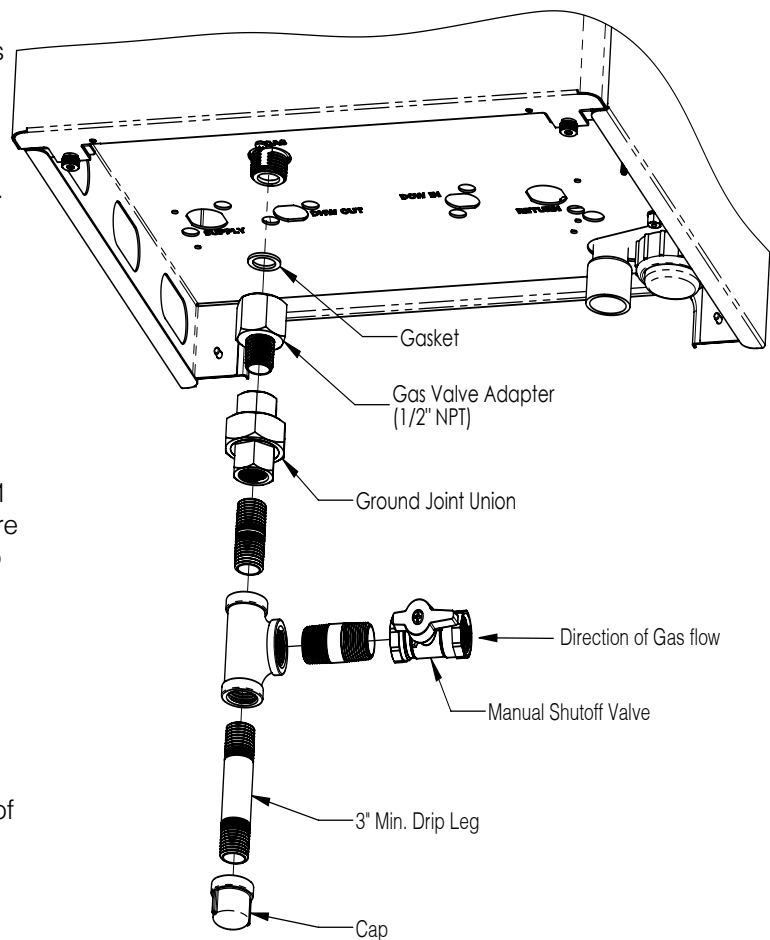

Figure 12-1: Gas Piping

13 Field Wiring

⚠ DANGER

Electrical Shock Hazard.

- Disconnect electrical supply before installing or performing maintenance.
- Electrical power may be supplied from more than one circuit.
- Lock out all electrical boxes with padlock once power is turned off.

⚠ WARNING

Electrical Shock Hazard.

All wiring and grounding must conform to requirements of authority having jurisdiction or, in absence of such requirements, to National Electrical Code/NFPA 70 or Canadian Electrical Code, Part 1 (CSA C22.1 - latest edition).

- Make electrical connections according to boiler's wiring diagram and instructions. Failure to properly wire electrical connections to the boiler may result in severe personal injury, death or substantial property damage.
- Protect each boiler circuit with a properly sized over-current device.
- Never jump out or bypass any safety or operating control or component of this boiler.

NOTICE: Internal wiring diagrams contained in this manual are for reference only. Each boiler is shipped with a wiring diagram sheet within boiler literature packet. Read, understand and follow this wiring diagram and wiring diagrams of any field supplied controls.

NOTICE: Boiler is equipped with a UL 353 listed high water temperature limit. This limit provides boiler shutdown in event boiler water temperature exceeds set point of control. Certain local codes require an additional water temperature limit. If necessary, install an additional water temperature limit (Honeywell L4006 Aquastat). Wire as indicated in Figure 13-3.

Locating Field Connection Terminal Strips

Field connection terminal strip locations are shown in Figure 13-1. To access terminal strips:

1. Remove front door. Front door is removed by first loosening two thumb screws located under front of door.
2. Disconnect igniter wire at burner door.
3. Pull control enclosure forward, then to the left and allow it to swing down into the service position.

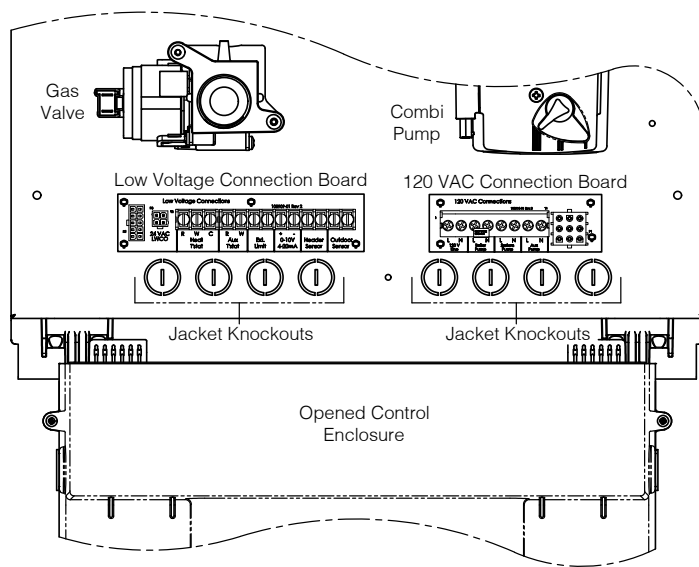

Figure 13-1: Location 120 VAC and Low Voltage Connection Boards

Field 120 VAC Connections

1. Provide a dedicated circuit for boiler of 15A or greater. A service switch is recommended and is required by many local codes. Locate this switch in accordance with local codes or, in absence of such requirements, in a location where it can be safely accessed in an emergency.
2. All 120 VAC connections to boiler are made on 120 VAC Connections terminal strip (see Figure 13-2) located on right side of bottom panel. Route all 120 VAC wiring through conduit knock out holes located on right side in front of terminal strip.

13 Field Wiring *(continued)*

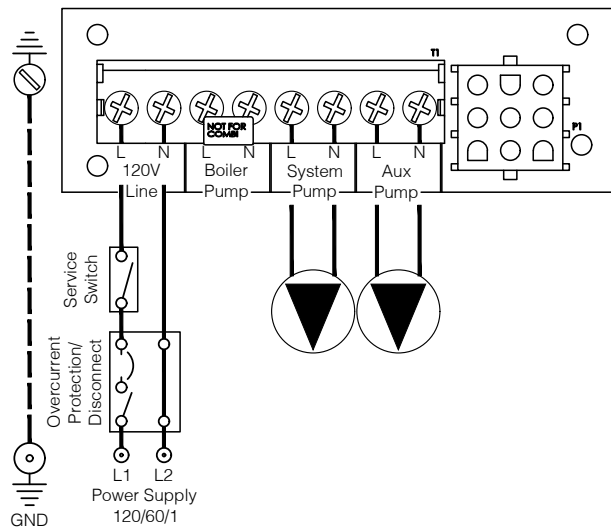

Figure 13-2: 120 VAC Connections

From left to right, connections on terminal strip are:

Terminal	Description
120 VAC L	Hot
120 VAC N	Neutral
Boiler Pump L	Not used on Combi
Boiler Pump N	Not used on Combi
System Pump L	Hot
System Pump N	Neutral
Auxiliary Pump L	Hot
Auxiliary Pump N	Neutral

3. Pump outputs

- A. System Pump: (field supplied) Circulates water through radiation. System pump is always on when boiler is responding to heating demand. Refer to Table 16-15 for alternate system pump output functions. Maximum recommended current draw for system pump is 1.5A.
- B. Auxiliary Pump: ("Recirculation pump") (field supplied) Circulates water through a DHW recirculation loop. Auxiliary pump output can be used for 2nd zone or indirect pump. Refer to Table 16-15 for more information and alternate auxiliary pump output functions. Maximum recommended current draw for auxiliary pump is 1.5A.
- C. Maximum combined current draw for all circulators is 5A. Internal boiler pump draws a maximum of 2A.

Low Voltage Connections

- All low voltage field connections to boiler are made on Low Voltage Connections terminal strip (see Figure 13-3) located on left side of bottom panel. Route all low voltage wiring through conduit knock out holes located on left side in front of terminal strip.

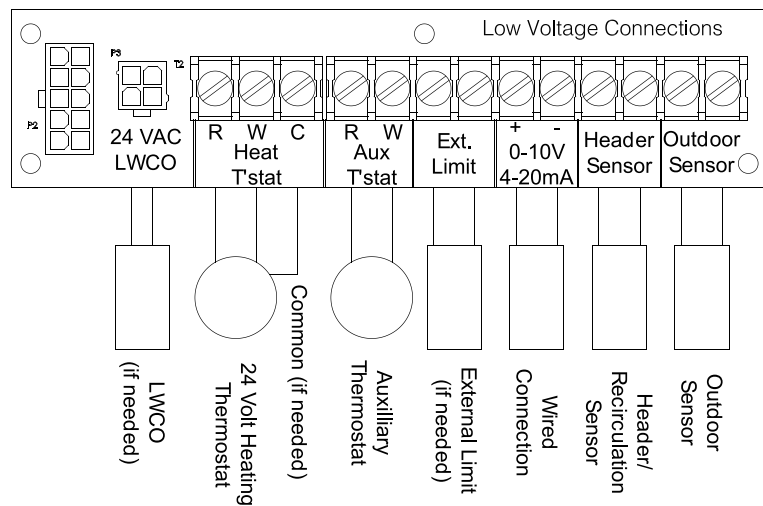

Figure 13-3: Low Voltage Connections

From left to right, connections on terminal strip are:

Terminal	Description
Heat T'Stat	24 VAC thermostat (R - 24V "Hot")
Heat T'Stat	24 VAC thermostat (W - Energized on Call for Heat)
Heat T'Stat	24 VAC thermostat (C - 24V Common)
Aux T'Stat	24 VAC thermostat (R - 24V "Hot")
Aux T'Stat	24 VAC thermostat (W - Energized on Call for Heat)
External Limit	Field supplied safety limit contacts (1)
External Limit	Field supplied safety limit contacts (2)
0-10 V 4-20mA	Optional remote modulation control* (+)
0-10 V 4-20mA	Optional remote modulation control* (-)
Header Sensor	Optional Recirculation (Header*) Temperature Sensor (1)
Header Sensor	Optional Recirculation (Header*) Temperature Sensor (2)
Outdoor Sensor	Optional Outdoor Temperature Sensor (1)
Outdoor Sensor	Optional Outdoor Temperature Sensor (2)

*Feature available with PAT-Connect Bluetooth Adaptor and App.

13 Field Wiring *(continued)*

2. External power must not be applied to any low voltage terminals - doing so may damage boiler control. Note following:
 - A. Heat T'Stat (field supplied) - Connect room thermostat or zone panel end switch (isolated contact only) to "Heat T'stat" terminals.
 - B. Aux T'Stat - Connect jumper, common recirculation timer (field supplied) or point of use push button (field supplied). Auxiliary T'Stat can also be used for 2nd zone or indirect demand. Refer to Table 16-13 for explanation.
 - C. External Limit: External limit terminals are intended for use with field supplied safety device, such as a manual reset high limit or LWCO. When an external limit is used, jumper between these two terminals must be removed.
 - D. Outdoor Sensor - Use only Tasseron TSA00AA (P/N 108681-01) 10k outdoor sensor. When optional sensor is connected, boiler control will provide outdoor air sensor based freeze protection interlocks. When placing sensor, consider following:
 - i. Locate sensor on outside of building.
 - ii. Avoid placing sensor in areas where it may be covered with ice or snow.
 - iii. Avoid direct radiation from sun.
 - iv. Avoid placing sensor near potential sources of electrical noise such as transformers, power lines, and fluorescent lighting.
 - v. Wire sensor to boiler using minimum 22 AWG wire.
 - vi. Where electrical noise sources cannot be avoided, wire sensor using 2 conductor, UL Type CM, AWM Style 2092 shielded cable. Connect one end of shielding on this cable to ground.
 - E. Recirculation (Header) Temperature Sensor - When optional sensor is installed and Recirculation (Comfort) Mode is enabled, boiler will attempt to maintain target domestic hot water recirculation temperature in recirculation piping. Use only Honeywell 32003971-003 (P/N 108703-01) sensor. Locate sensor as shown in Figure 11-3. Wire sensor using a 2 conductor, UL Type CM, AWM Style 2092, 300 Volt 60°C shielded cable. Connect one end of shielding on this cable to ground. See Table 16-11 for information on enabling recirculation sensor.
 - F. LWCO wiring - Although not necessary to protect this boiler, some jurisdictions may require installation of LWCO with this boiler.
 - i. Refer to Section 10 Heating System Piping for LWCO kits available from manufacturer.
 - ii. LWCO from these kits is installed to 4 pin connector on Low Voltage Connections terminal strip.
 - G. RJ45 Connections - Boiler-to-Boiler communication network is used for multiple boiler ("Lead-Lag") installations.

Note: Combi boilers may only be used as slaves in such a system. Refer to Table 16-16 for information on enabling this feature. Boiler lead/lag sequencer connection is made directly to control. Refer to Figure 13-4.

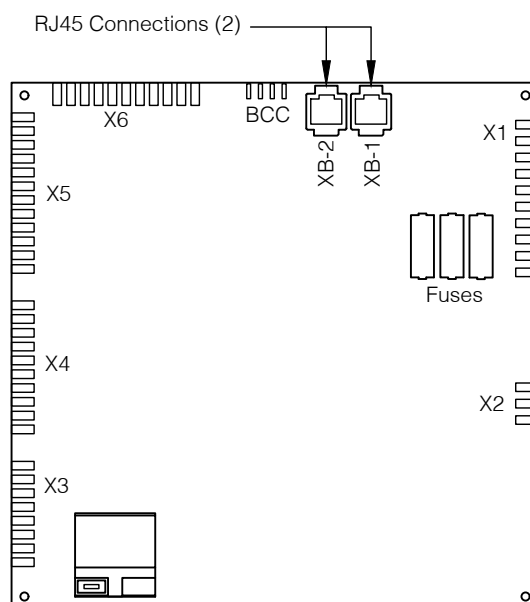
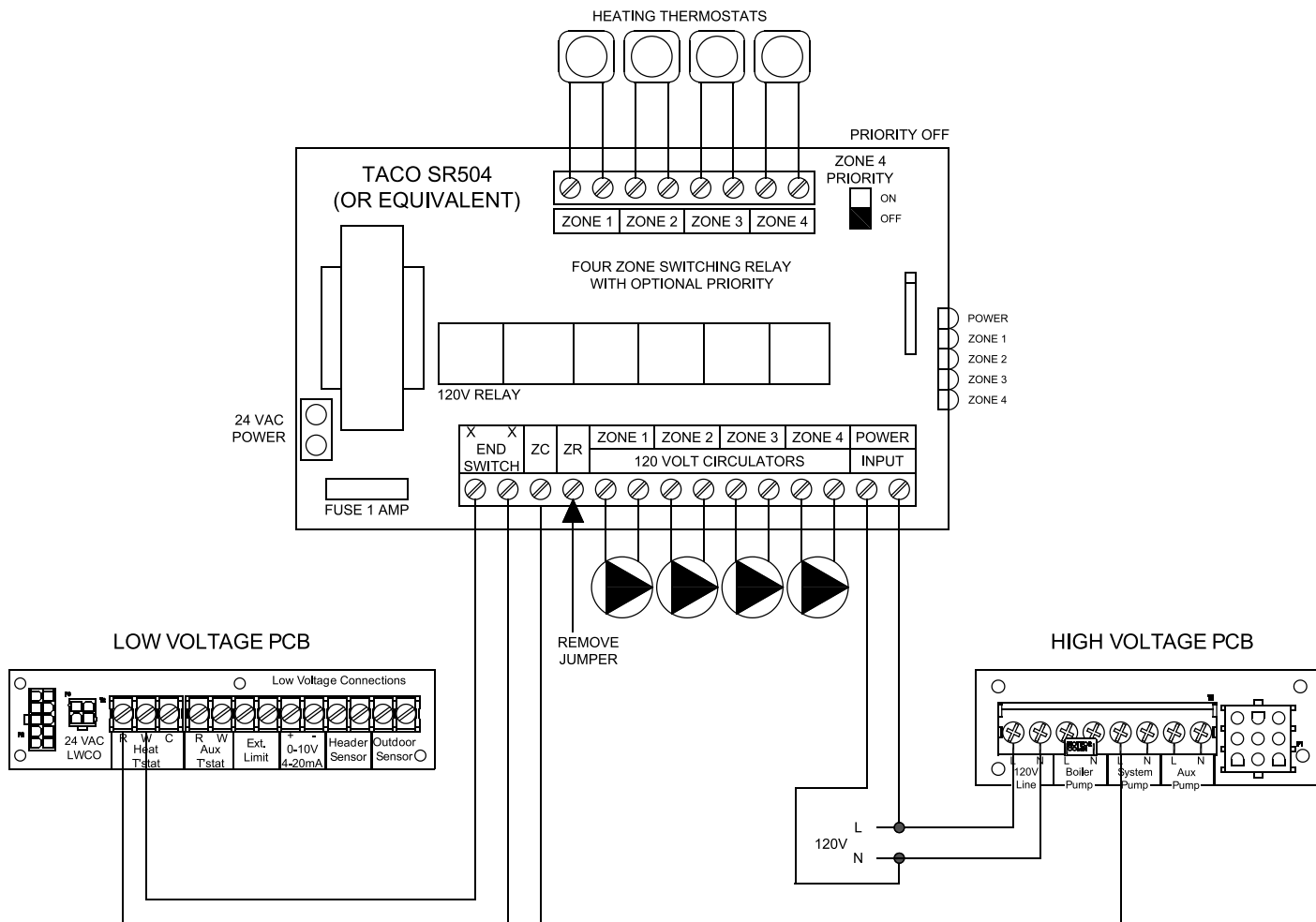

Figure 13-4: Boiler-to-Boiler Connections

13 Field Wiring *(continued)*



*****USE SAME POWER SOURCE FOR ALL CONTROLS AND ENSURE POLARITY TO ALL CONTROL DEVICES IS CORRECT**

Figure 13-5: TACO SR504 or Equivalent Zone Panel Wiring Connection Diagram

14 Condensate Disposal

⚠ WARNING

Asphyxiation Hazard.

Failure to install condensate drain in accordance with instructions outlined below could cause products of combustion and/or carbon monoxide to enter building, resulting in severe personal injury, death or substantial property damage.

1. This high efficiency boiler produces condensate.

NOTICE: Condensate is corrosive. Use only materials listed by authority having jurisdiction. In absence of such requirements, PVC and CPVC pipe may be used.

2. 3/4 in. PVC condensate drain connection can be solvent welded.
3. Condensate disposal considerations:
 - A. If required by local codes, install neutralizing filter. Neutralizing kit P/N 101897-01 is available from manufacturer.

- B. Do not route or terminate condensate drain line piping through an area that is prone to freezing temperatures or that could be damaged by leaking condensate.
- C. If point of condensate disposal is above trap, it will be necessary to use a condensate pump to move condensate from boiler to drain.

In such cases, select a condensate pump that is listed for use with condensing boilers.

Select a pump with an overflow switch to prevent property damage from condensate.

- D. Barbed fitting on bottom panel is connected to trap vent and must be unobstructed for trap to work properly.

NOTICE: If condensate drain line becomes obstructed, boiler may leak from condensate trap vent. Consider installing drain pan directly below boiler if such a leak could cause property damage. Pipe drain pan drain to suitable location.

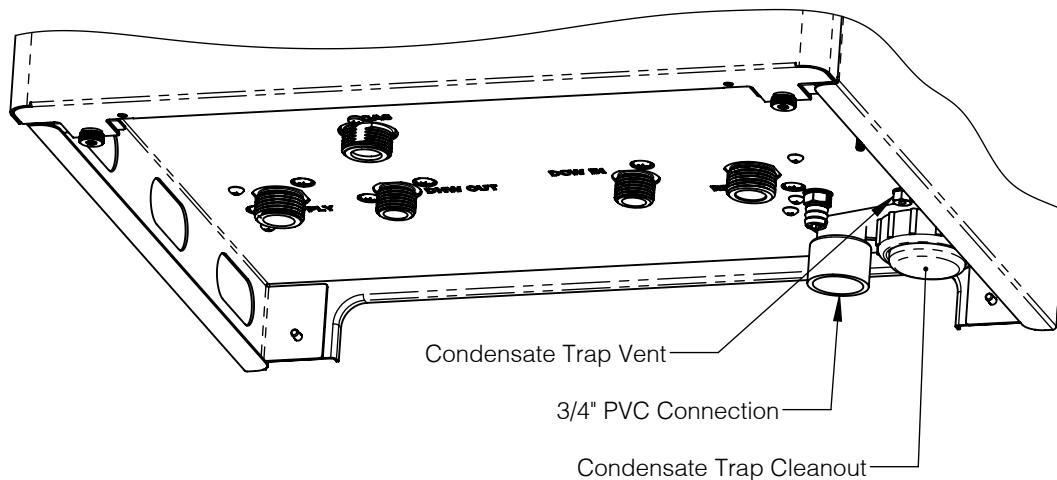

Figure 14-1: Condensate Trap

15 Start-Up and Checkout

Heating System Cleaning and Treatment

CAUTION

Component Damage.

Proper flushing, cleaning, and water side maintenance is highly recommended to protect boiler heat exchanger. Scaling and sediment build up may not be covered under warranty.

1. Prior to fill, flush entire heating system to remove sediment, flux, and traces of boiler additives.
2. Clean with approved cleaners such as the following or its equivalent:
 - Fernox Cleaner F3 (for new heating systems)
 - Sentinel x300 System cleaner (for new heating systems)
 - Sentinel X400 System Restorer (for old closed loop hydronic systems)

Refer to instructions supplied with cleaner for proper dosage and use.

NOTICE: Cleaning system prior to removing old boiler or by isolating new boiler from system while cleaning will yield best results.

3. After system has been cleaned, recommend using approved inhibitors such as the following or its equivalent:
 - Fernox F1 Protector
 - Sentinel X100 Inhibitor

Refer to instructions supplied with inhibitor for proper dosage and use.

CAUTION

Component Damage.

Avoid use of petroleum based boiler additives and ester-based oils/lubricants. These could attack seals in both boiler and system which could result in property damage.

Fill Water Quality

NOTICE: Make sure system is filled with water meeting the following criteria:

- Hardness less than 7 grains/gallon.
- pH between 6.5 and 9.5 (for systems containing aluminum components, between 6.5 and 8.5)
- Chlorides less than 200 PPM. If fill water is drawn from a system containing a water softener, test a sample of the water to confirm that this criteria is met.

Following appropriate water chemistry guidelines will help extend the life of appliance by reducing effects of lime scale buildup and corrosion, which are not covered by warranty.

NOTICE: Minimize introduction of make-up water, dissolved oxygen, and contaminants into boiler by following installation guidelines outlined in Appendix B: Water Quality and Boiler Additives.

Freeze Protection

If freeze protection is required see Appendix B for additional information.

Fill Water System

WARNING

Burn Hazard.

Never exceed maximum allowable working pressure on heat exchanger ASME plate (50 psig [345 kPa]). A 30 psig (207 kPa) safety relief valve is included with this boiler.

1. Fill system ensuring water quality meets requirements of this manual.
2. Pressurize system to at least 12 psig (83 kPa) at boiler. Pressure will vary with each application.
3. Verify air pressure in expansion tank is equal to system pressure.

15 Start-Up and Checkout *(continued)*

4. Eliminate air in boiler by bleeding from heat exchanger manual air vent on top left side of heat exchanger (Figure 15-1).
 - A. Use 1/4 in. (6 mm) ID tubing connected to hose barb and route tubing to a safe draining location.
 - B. Turn vent counter clockwise and allow heat exchanger to vent until a steady stream of water is observed.
 - C. Close vent and remove hose.

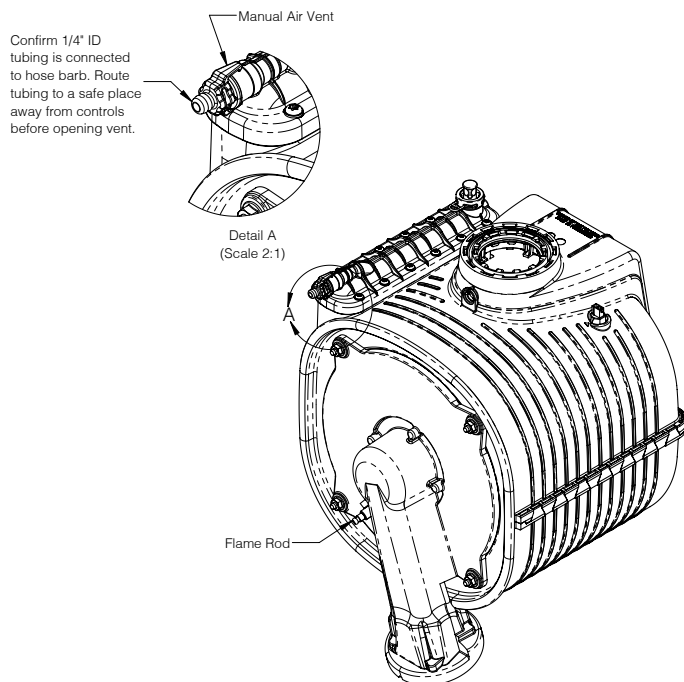

Figure 15-1: Manual Air Vent Location

5. Isolate each zone to purge air confirming that heating system and boiler are completely filled.
6. Verify automatic air vent located on internal piping is open and remains open to atmosphere. See Figure 4-1 for location.

Final Check Before Starting Boiler

WARNING

Asphyxiation Hazard. Burn Hazard.

Completely read, understand and follow all instructions in this manual before attempting start-up.

1. Verify that venting, water piping, gas piping and electrical system are installed properly.
2. Confirm vent system is complete and free of obstructions before attempting to fire boiler.
3. Inspect all wiring for loose, uninsulated or miswired connections.
4. Verify boiler and system are full of water and pressurized. Verify pump speed is set to 3. (Figure 15-2) Pump located on right side of boiler.

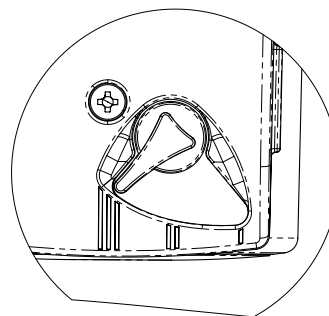

Figure 15-2: Pump speed setting

NOTICE: When boiler is first powered, control will automatically run a pump purge sequence (status 10) for 2 minutes.

5. Check all gas piping before boiler manual shut-off valve for leaks and purge sections that are filled with air. Refer to NFPA 54/ANSI Z223.1 *National Fuel Gas Code* and/or CAN/CSA B149.1 *Natural Gas and Propane Installation Code* for additional information on testing and purging gas lines.

DANGER

Explosion Hazard.

Do not use matches, candles, open flames or other ignition source to check for leaks. Failure to comply could result in severe personal injury, death or substantial property damage.

NOTICE: Boiler is shipped from factory configured for Natural Gas (NG) 0-2,000 ft. (0-610 m).

6. If required, please proceed with fuel conversion and altitude conversion. Otherwise, skip to final check continued.

15 Start-Up and Checkout *(continued)*

LP Conversion

⚠ WARNING

Asphyxiation Hazard.

- Do not attempt to operate this boiler on LP gas without making proper adjustments to gas valve and control. Do not convert this boiler to LP gas without using a combustion analyzer to verify CO does not exceed 200 ppm air free for altitudes 0 to 2,000 ft. (0 to 610 m) and 300 ppm air free for altitudes above 2,000 ft. (610 m). (In event of high CO, consult section 19 Troubleshooting).
- Failure to properly convert this boiler for use on LP gas could cause unreliable operation at elevated carbon monoxide (CO) levels, resulting in severe personal injury, death or substantial property damage.
- Do not attempt to operate 200 combi above 2,000 ft. (610 m) on LP without proper conversion kit.

LP conversion requires (2) steps: gas valve setting adjustment and control parameter change.

1. Use 2.5 mm hex wrench to adjust gas valve setting from "1" to "2" (Figure 15-3).

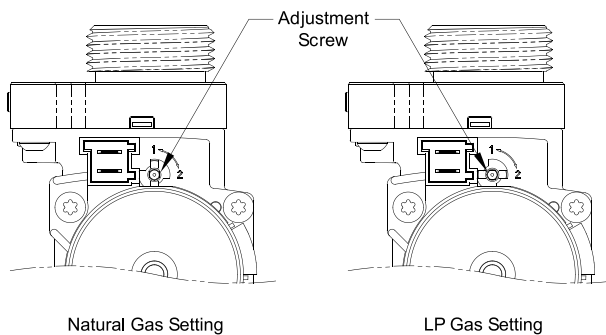

Figure 15-3: Gas Valve Fuel Setting

2. For 200 combi installations above 2,000 ft. (610 m), replace electrode shipped with boiler with electrode from conversion kit 111745-01.

3. Use keypad to enter adjust mode and change parameter *AD5* from "0" to "1".
 - Press and hold "menu" for 3 seconds.
 - Press "↑" or "↓" buttons until *PA5* is visible and press "enter".
 - Press "enter" button while *PA1* is visible.
 - Press "+" or "-" buttons until password "88" is reached and press "enter". Press and hold for five seconds to adjust by increments of 10.
 - Press "menu" button until *PA5* is visible.
 - Press "↑" button until *A* is visible and press "enter".
 - Press "↑" or "↓" buttons until *AD5* is visible and press "enter".
 - Press "+" or "-" buttons to change "0" to "1".
 - Press "menu" 3 times to return to display mode.
4. Apply yellow LP gas conversion label, supplied with boiler literature packet, to jacket beside rating label.

High Altitude Conversion

⚠ WARNING

Asphyxiation Hazard.

Do not attempt to operate boiler at altitude without making proper adjustments to control.

1. Change parameter *AD7* (altitude selection) according to the following table. Control is shipped from factory with *AD7* default value of 0.

Table 15-4: *AD7* Value

Altitude Selection <i>AD7</i>	
0	0-2,000 ft. (0 to 610 m)
1	2,001-6,000 ft. (611 m to 1,828 m)
2	6,001-8,000 ft. (1,829 to 2,438 m)
3	8,001-10,100 ft. (2,439 m to 3,079 m)

NOTICE: See Table 3-4 for associated de-rates for altitude.

15 Start-Up and Checkout *(continued)*

Final Check Before Starting Boiler (continued)

1. Start boiler using lighting instructions in Figure 15-10. With boiler powered up, and with no call for heat, display should look like Figure 15-5. Once a call for heat is present, it will look like Figure 15-6.

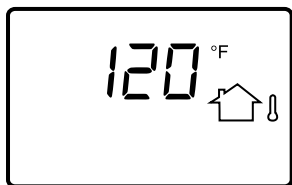

**Figure 15-5: Home Screen at Power Up
(no call for heat)**

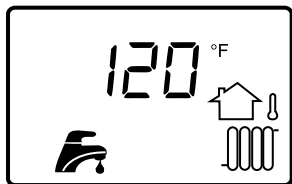

**Figure 15-6: Home Screen with CH and DHW
Demands**

2. Boiler should attempt to fire several seconds after a call for heat appears. With front door removed, try for ignition will appear as an audible spark (lasting approximately 4 seconds).
3. Upon initial start-up, gas train will be filled with air. Even if gas line has been completely purged of air, it may take several tries for ignition before a flame is established.

4. If boiler does not light after 2 retries for ignition, it will enter a "soft lockout" and will wait for one hour before attempting another ignition sequence. This soft lockout can be reset by interrupting power to boiler.
5. Once a flame has been established for first time, subsequent calls for burner operation should result in a flame on first try.
6. If there is a problem, display will show error code (Figure 15-7). Refer to label on access door and Section 19 troubleshooting to diagnose error.



Figure 15-7: Home Screen with Error

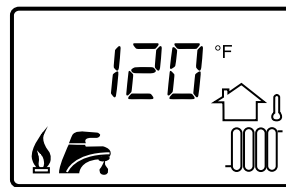

Figure 15-8: Home Screen While Running

7. If successful ignition, display will show flame icon (Figure 15-8).
8. Boiler will automatically perform a calibration to properly set its air-fuel ratio (i.e. O₂ or CO₂ and CO levels).

15 Start-Up and Checkout *(continued)*

9. Check inlet gas pressure (Figure 15-9). Verify inlet gas pressure is between upper and lower limits shown on rating label with all gas appliances on and off. Be sure to close this pressure tapping when gas pressure check is complete.

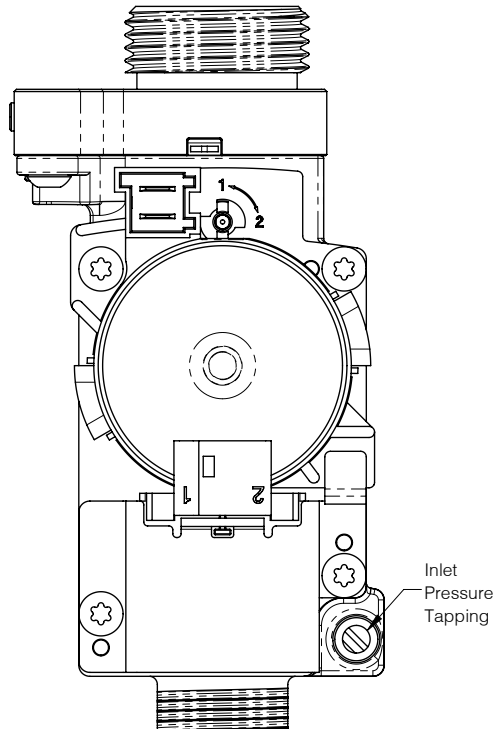

Figure 15-9: Gas Valve Inlet Pressure Tap

⚠ WARNING

Explosion Hazard.

Ensure inlet pressure tapping is fully closed after checking pressure. Failure to comply could result in severe personal injury, death, or substantial property damage.

10. Perform combustion test.

⚠ WARNING

Asphyxiation Hazard.

Use a combustion analyzer to verify proper operation by checking carbon monoxide (CO) levels. Failure to use a combustion analyzer could cause operation of boiler with elevated CO levels resulting in severe personal injury, death or substantial property damage.

- A. Boiler is equipped with a screw cap in vent adapter. Be sure to replace this cap when combustion testing is complete.
 - B. Measure carbon monoxide (CO) level after 5 minutes of operation above 50% firing rate. This can be done by providing DHW demand. Ensure door is sealed before taking combustion readings.
 - C. For altitudes 0 to 2,000 ft. (0 to 610 m) CO should not exceed 200 ppm air free. For altitudes above 2,000 ft. (610 m), CO should not exceed 300 ppm air free. (in event of high CO, see Section 19 Troubleshooting).
11. Perform a check of ignition safety shut-off device. With burner firing, carefully unplug black ignitor/ flame sensor wire at burner door using a pair of insulated pliers (Figure 15-1). Burner should shut off immediately.
 12. Test any external limits or other controls in accordance with manufacturer's instructions.
 13. Refer to Section 16 Operation to set-up control for system in which boiler is installed. Some common set-up tasks include:
 - A. Setting CH and DHW temperature set-points.
 - B. Defining system pump operation.
 - C. Setting parameters for recirculation (comfort) mode. See Figure 11-3 for details.
 14. Review User's Information Manual and system operation with homeowner.

15 Start-Up and Checkout *(continued)*

FOR YOUR SAFETY READ BEFORE OPERATING/POUR VOTRE SÉCURITÉ LISEZ AVANT DE METTRE EN MARCHÉ

WARNING: If you do not follow these instructions exactly, a fire or explosion may result causing property damage, personal injury or loss of life.

AVERTISSEMENT: Quiconque ne respecte pas à la lettre les instructions dans la présente notice risque de déclencher un incendie ou une explosion entraînant des dommages, des blessures ou la mort.

- A. This appliance does not have a pilot. It is equipped with an ignition device which automatically lights the burner. Do **not** try to light the burner by hand.
- B. BEFORE OPERATING smell all around the appliance area for gas. Be sure to smell next to the floor because some gas is heavier than air and will settle on the floor.

WHAT TO DO IF YOU SMELL GAS:

- Do not try to light any appliance.
 - Do not touch any electric switch; do not use any phone in your building.
 - Immediately call your gas supplier from a neighbor's phone. Follow the gas supplier's instructions.
 - If you cannot reach your gas supplier, call the fire department.
- C. Use only your hand to turn the gas control valve. Never use tools. If the valve will not turn by hand, don't try to repair it, call a qualified service technician. Force or attempted repair may result in a fire or explosion.
- D. Do not use this appliance if any part has been under water. Immediately call a qualified service technician to inspect the appliance and to replace any part of the control system and any gas control which has been under water.

- A. Cet appareil ne comporte pas de veilleuse. Il est muni d'un dispositif d'allumage qui allume automatiquement le brûleur. Ne tentez pas d'allumer le brûleur manuellement.
- B. AVANT DE FAIRE FONCTIONNER, reniflez tout autour de l'appareil pour détecter une odeur de gaz. Reniflez près du plancher, car certains gaz sont plus lourds que l'air et peuvent s'accumuler au niveau du sol.

QUE FAIRE SI VOUS SENTEZ UNE ODEUR DE GAZ:

- Ne pas tenter d'allumer d'appareil.
 - Ne touchez à aucun interrupteur ; ne pas vous servir des téléphones se trouvant dans le bâtiment.
 - Appelez immédiatement votre fournisseur de gaz depuis un voisin. Suivez les instructions du fournisseur.
 - Si vous ne pouvez rejoindre le fournisseur, appelez le service des incendies.
- C. Ne poussez ou tournez la manette d'admission du gaz qu'à la main ; ne jamais utiliser d'outil. Si la manette reste coincée, ne pas tenter de la réparer ; appelez un technicien qualifié. Le fait de forcer la manette ou de la réparer peut déclencher une explosion ou un incendie.
- D. N'utilisez pas cet appareil s'il a été plongé dans l'eau, même partiellement. Faites inspecter l'appareil par un technicien qualifié et remplacez toute partie du système de contrôle et toute commande qui ont été plongés dans l'eau.

OPERATING INSTRUCTIONS/ INSTRUCTIONS DE FONCTIONNEMENT

1. **STOP!** Read safety information above on this label.
2. Set the thermostat to lowest setting.
3. Turn off all electric power to the appliance.
4. This appliance is equipped with an ignition device which automatically lights the burner. Do **not** try to light the burner by hand.
5. Turn the external boiler manual gas valve handle clockwise ↻ to close the gas supply (OFF Position).
6. Wait five (5) minutes to clear out any gas. Then smell for gas, including near the floor. If you smell gas, STOP! Follow "B" in the safety information above on this label. If you don't smell gas, go to the next step.
7. Turn the external boiler manual gas valve handle counterclockwise ↺ to open the gas supply (ON Position).
8. Turn on all electric power to the appliance.
9. Set the thermostat to the desired setting.
10. If the appliance will not operate, follow the instructions "To Turn Off Gas To Appliance" and call your service technician or gas supplier.

1. **ARRÊTEZ !** Lisez les instructions de sécurité sur la portion supérieure cette étiquette.
2. Réglez le thermostat à la température la plus basse.
3. Coupez l'alimentation électrique de l'appareil.
4. Cet appareil est équipé de l' dispositif d'allumage qui allume automatiquement le brûleur. Ne tentez pas d'allumer le brûleur manuellement.
5. Tourner la chaudière externe manuelle poignée ↻ en clapet à gaz dans le sens des aiguilles d'une montre pour fermer l'offre de gaz (Position OFF).
6. Attendre cinq (5) minutes pour laisser échapper tout le gaz. Reniflez tout autour de l'appareil, y compris près du plancher, pour détecter une odeur de gaz. Si vous sentez une odeur de gaz, ARRÊTEZ ! Passez à l'étape B des instructions de sécurité sur la portion supérieure de cette étiquette. S'il n'y a pas d'odeur de gaz, passez à l'étape suivante.
7. Tourner la chaudière externe manuelle compteur de poignée ↺ en clapet à gaz ouvrir dans le sens des aiguilles d'une montre le gaz approvisionnement (Position ON).
8. Mettez l'appareil sous tension.
9. Réglez le thermostat à la température désirée.
10. Si l'appareil ne se met pas en marche, suivez les instructions intitulées « Comment couper l'admission de gaz de l'appareil » et appelez un technicien qualifié ou le fournisseur de gaz.

OPEN/OUVERT



CLOSED/FERMÉ



EXTERNAL BOILER
MANUAL GAS VALVE
LA CHAUDIÈRE EXTERNE
MANUELLE DE CLAPET À GAZ

TO TURN OFF GAS TO APPLIANCE/ COMMENT COUPER L'ADMISSION DE GAZ DE L'APPAREIL

1. Set the thermostat to lowest setting.
2. Turn off all electric power to the appliance if service is to be performed.
3. Turn the external boiler manual gas valve handle clockwise ↻ to close gas supply (OFF Position).

1. Réglez le thermostat à la température la plus basse.
2. Coupez l'alimentation électrique de l'appareil s'il faut procéder à l'entretien.
3. Tourner la chaudière externe manuelle poignée ↻ en clapet à gaz dans le sens des aiguilles d'une montre pour fermer l'offre de gaz (Position OFF).









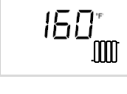

101607-04

Figure 15-10: Lighting and Operating Instructions

15 Start-Up and Checkout *(continued)*

Boiler Sequence of Operation

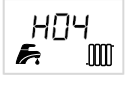
Table 15-11: Boiler Sequence of Operation

Status Screen Display	Description
 <p>Priority: Standby Status: Standby</p>	<p>Burner - Off Pump(s) - Off Three Way Valve - DHW</p> <p>There is no call for heat, boiler is not firing and priority is "standby". Boiler is ready to respond to a call for heat. Additionally, boiler and pumps remain off when Warm Weather Shut Down is active or "Boiler Switch" (RD I) is set to "Off".</p>
 <p>Priority: Standby Status: Pump Purge</p>	<p>Burner - Off Pump(s) - Cycle Three Way Valve - Cycle</p> <p>Pump Air Elimination (Pump Purge) is entered when power is cycled or when there has been a supply high limit hold. During this state boiler pump and three way valve cycle in sequence for two minutes to help remove air from boiler water piping. This may be interrupted by pressing " reset" button.</p>
 <p>Priority: Central Heat Status: Standby</p>	<p>Burner - Off Pump(s) - Cycle Three Way Valve - CH</p> <p>Boiler is not firing. There is a CH demand and supply temperature is greater than setpoint minus "Diff Below".</p>
 <p>Priority: Central Heat Status: Prepurge</p>	<p>Burner - Off Pump(s) - On Three Way Valve - CH</p> <p>When supply temperature drops, burner demand continues with following status shown: Waiting For Limit To Close: blower started, air pressure switch is checked. Prepurge: blower is driven to prepurge speed to empty chamber of flue products.</p>
 <p>Priority: Central Heat Status: Burner Ignition</p>	<p>Burner - On Pump(s) - On Three Way Valve - CH</p> <p>After prepurge is complete following status is shown: Burner Ignition: Spark and fuel valve are energized.</p>
 <p>Priority: Central Heat Status: Calibration</p>	<p>Burner - On Pump(s) - On Three Way Valve - CH</p> <p>After burner is started, a Calibration is initiated due to 1. Power Cycle 2. Periodic requirement Calibration: after blower reaches calibration speed setting, flame signal setpoint is calibrated, next blower drives to low fire and fuel valve output is calibrated (runs for 1 minute).</p>
 <p>Priority: Central Heat Status: Run</p>	<p>Burner - On Pump(s) - On Three Way Valve - CH</p> <p>After burner ignition (following calibration), the following status is shown: Low Fire Hold: modulation rate held at low fire to allow initial home heating Run (Modulate): Burner rate modulates to match home heat requirements.</p>
 <p>Priority: DHW Status: Run</p>	<p>Burner - On Pump(s) - On Three Way Valve - DHW</p> <p>If CH demand is active and a DHW demand is received, DHW demand becomes "priority" and modulation rate, setpoint, "Diff Above" and "Diff Below" are based on DHW settings.</p>
 <p>Priority: Standby Status: Post-purge</p>	<p>Burner - Off Pump(s) - Off Three Way Valve - Cycle</p> <p>If there is no call for heat, fuel valve is closed and blower is driven to post-purge speed to empty combustion chamber of flue products.</p>
 <p>Priority: Standby Status: Hold</p>	<p>Burner - Off Pump(s) - Off Three Way Valve - Cycle</p> <p>Hold status is entered when a delay is needed before allowing burner to fire. See user display door label or section 19 Troubleshooting to determine cause of the Hold.</p>
 <p>Priority: Standby Status: Lockout</p>	<p>Burner - Off Pump(s) - Off Three Way Valve - Cycle</p> <p>A lockout status is entered to prevent boiler from running due to a detected problem. See user display door label or section 19 Troubleshooting to determine cause of Lockout. Last 8 Lockouts are recorded in Lockout History.</p>

16 Operation

User Display Overview

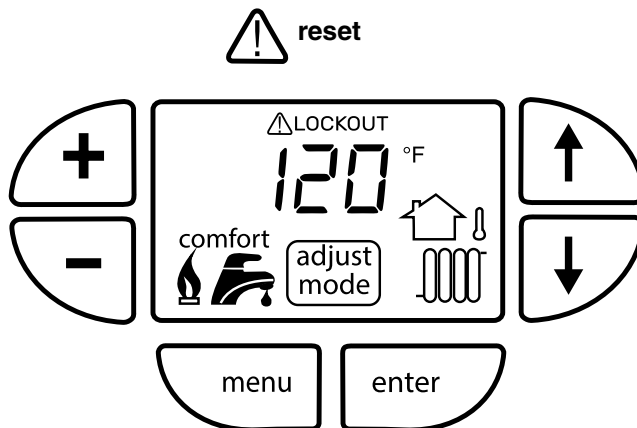







Figure 16-1: Display Icons

Table 16-2: Display Descriptions

120°F	When not flashing or alternating display temperature is: <ul style="list-style-type: none"> • DHW outlet temperature during DHW priority. • Boiler supply temperature at all other times.
	Visible when Central Heat demand is present.
	Visible when DHW demand is present. Icon will flash if DHW setpoint is being adjusted.
	Visible when burner is firing. Icon adjacent to active priority.
comfort	Visible when Recirculation (Comfort) Mode is active. (Visible after successful calibration.)
	Visible when CH setpoint reset is enabled.
adjust mode	Visible when adjust mode is active. Icon will flash if manual mode is enabled.
 LOCKOUT	Visible when manual reset lockout is active.

16 Operation *(continued)*

Operating Mode

Basic boiler status is displayed and DHW setpoint may be adjusted.

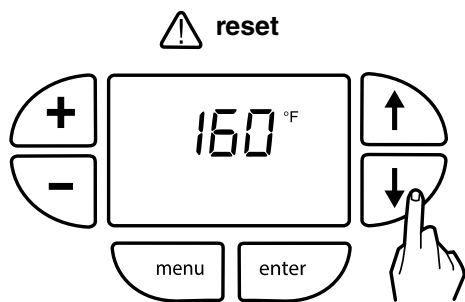

Figure 16-3: Viewing Boiler Status

Press "↑" or "↓" buttons to cycle through Status List. Each item will alternate between status code and its corresponding value.

Table 16-4: Status List

Display	Description
5LR	Status (see Table 16-5)
5P	Active, Operating Setpoint
bT	Boiler Supply Temperature
rT	Boiler Return Temperature
dT	DHW Temperature
dR	DHW Flow Rate
Ft	Flue Temperature
oT	Outdoor Air Temperature*
hT	Recirculation (Header*) Temperature
F _r	Demanded Firing Rate
rUn	Run Time Hours
CYC	Boiler Cycles
H##	Hold or Warning Condition
E##	Manual Reset Lockout

* Feature available with PAT-Connect Bluetooth Adaptor and App.

The 5LR (status) display code contains below listed values.

Table 16-5 Managing of Status Numbers

Display	Description (see Section 19 Troubleshooting for explanation)
0	Self Check
1	Standby
2	Waiting For Air Pressure Switch To Close
3	Prepurge
4	Burner Ignition
5	Calibration
6	Low Fire Hold
7	Rate Limit
8	Run (Modulate)
9	Postpurge
10	Pump Air Elimination (2 minutes)
11	Standby Delay
12	Lockout
13	Boiler On/Off Switch (R0 I)
14	Warm Weather Shutdown*

* Feature available with PAT-Connect Bluetooth Adaptor and App.

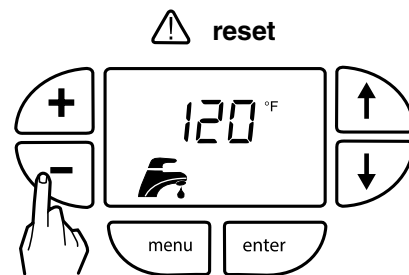

Figure 16-6: Adjusting DHW Setpoint

Press "+" or "-" buttons to immediately change the DHW setpoint. Faucet and DHW Setpoint flash while editing.

16 Operation *(continued)*

Adjust Mode Menu

Diagnostic information and Quick Menu parameters are available without entering a password. Press and Hold "menu" button for 3 seconds to access Adjust Mode.

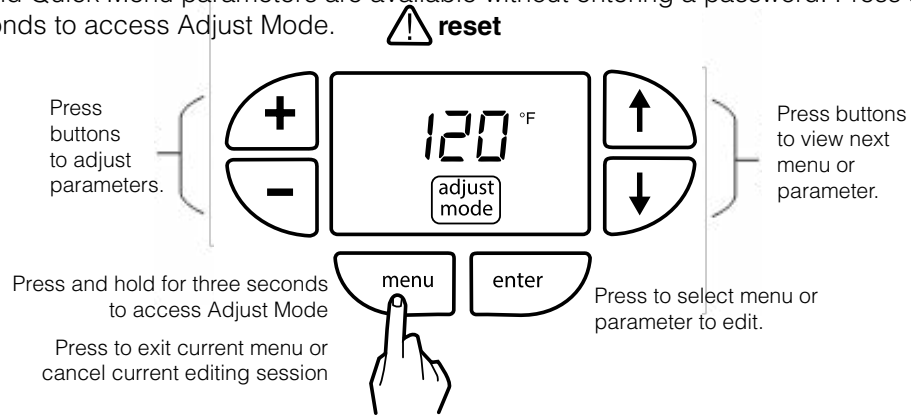

Figure 16-7: Adjusting Parameters

Press "↑" or "↓" buttons to switch between menus *A*, *b*, *c*, and *PAR*, press "enter" to Select. The following items are available in the *A* menu.

Menu *A*, Quick Menu

Table 16-8: Quick Menu (with no password entered)

Display	Range	Description
<i>AD1</i>	On/Off	Boiler On/Off Switch
<i>AD2</i>	On/Off	Recirc (Comfort) Mode
<i>AD3</i>	60 -140°F (16 - 60°C)	DHW Setpoint
<i>AD4</i>	60 - 190°F (16 - 88°C)	Central Heat 1 Setpoint
<i>AD5</i>	60 -190°F (16 - 88°C)	Central Heat 2 Setpoint

AD1 Boiler Switch

Allows an installer to prevent boiler starts while reviewing boiler settings.

AD2 Recirculation (Comfort) Mode

Recirculation (Comfort) Mode monitors recirculation sensor and controls a recirculation pump wired to Auxiliary Pump terminals. Comfort mode helps keep water warm to be immediately available at fixtures.

AD3 DHW Setpoint

Desired temperature of DHW produced by boiler.

AD4 Central Heating 1 Setpoint

Desired water temperature of Central Heat 1 (CH1).

AD5 Central Heating 2 Setpoint

Desired water temperature of Central Heat 2 (CH2).

Menu *b*, Lockout/Hold History Menu

b01 to *b08* are Lockout or Hold history records. *b01* is latest entry. To clear error code history, scroll to *b01* and hold reset button until *b01* = 0

Menu *c*, Diagnostic Menu

Table 16-9: Diagnostic Menu

Display	Description
<i>c01</i>	Active Detailed Fault Code (see Table 19-6)
<i>c02</i>	Demand Source
	1 Standby
	2 Central Heat 1
	3 Central Heat 2
	4 Domestic Hot Water
	5 Sequencer Control
	6 CH Frost Protection
	7 DHW Frost Protection
	8 Boiler On/Off Switch
9 Warm Weather Shutdown	
<i>c03</i>	Fan Speed Demanded (RPM x 100)
<i>c04</i>	Fan Speed Feedback (RPM x 100)
<i>c05</i>	Three Way Valve Status (0) DHW, (1) CH
<i>c06</i>	System Pump On/Off Status
<i>c07</i>	Boiler Pump On/Off Status
<i>c08</i>	Auxiliary Pump On/Off Status
<i>c09</i>	Flame Signal
<i>c10</i>	Safety Software Revision
<i>c11</i>	Application Software Revision
<i>c12</i>	Parameter Revision
<i>c13</i>	Boiler Size Status: (1) 136 combi
	(2) 200 combi
	(3) 080 heat only
	(4) 120 heat only
	(5) 150 heat only
	(6) 180 heat only
	(7) 136 combi (B)
	(8) 120 heat only (B)

16 Operation *(continued)*

Accessing Password Protected Menus

Password protected parameters are available by entering a password.

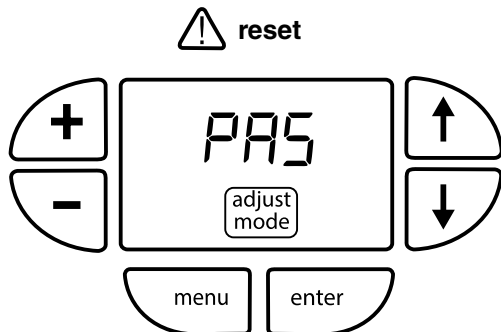

Figure 16-10: Menu Structure

Press and hold the "menu" for 3 seconds,

Press "↑" or "↓" buttons until *PAS* is visible and press "enter".

Press "enter" while *PA I* is visible.

Press "+" or "-" buttons until desired value is reached (password is 86).

(Press and hold for 5 seconds enables adjustment by increments of 10)

Press "enter" to accept value (password only).

Pressing "menu" to exit.

Navigating Menus

Entering password in "Adjust Mode" allows access to shaded menus below and additional items in Quick Menu.

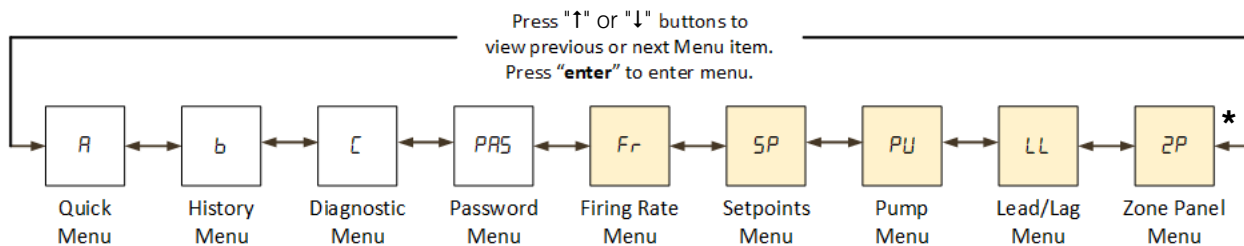

Menu Structure

* Only shows when communicating Zone Panel connected

IMPORTANT

This boiler is equipped with a feature that saves energy by reducing boiler water temperature as heating load decreases. This feature is equipped with an override which is provided primarily to permit the use of an external energy management system that serves the same function. **THIS OVERRIDE MUST NOT BE USED UNLESS AT LEAST ONE OF THE FOLLOWING CONDITIONS IS TRUE:**

- An external energy management system is installed that reduces boiler water temperature as heating load decreases.
- This boiler is not used for any space heating.
- This boiler is part of a modular or multiple boiler system having total input of 300,000 BTU/hr or greater.
- This boiler is equipped with a tankless coil.

WARNING

Asphyxiation Hazard.

- Parameter changes should only be made by a qualified installer, service agency or gas supplier.
- Fuel Gas Selection (parameter *AD6*) must match fuel gas supply **AND** gas valve fuel setting (see Figure 15-3).
- Altitude Selection (parameter *AD7*) must match boiler installation location. Only change these settings if required to match site conditions. These settings determine minimum and maximum blower speeds.
- Incorrect fuel gas and altitude settings could cause unreliable operation at elevated carbon monoxide (CO) levels, resulting in severe personal injury, death or substantial property damage.

16 Operation *(continued)*

Table 16-11: Menu A, Quick Menu (items A06, A07, A08 and A09 visible only after password entered)

Default	Range/ Choices	Parameter and Description
On	On/Off	A01 Boiler On/Off Switch Boiler switch allows an installer to prevent boiler starts while boiler powered and reviewing boiler settings. Control is factory set with boiler switch in "On" position.
Off	On/Off	A02 Recirculation (Comfort) Mode Recirculation (Comfort) Mode may be used to keep DHW water warm that is immediately available at fixtures. A recirculation piping system that supplies water to fixtures and then back to boiler is required to use this feature. This feature requires a recirculation sensor wired to the "Header Sensor" terminals, and a recirculation pump wired to the "Aux Pump" terminals. Refer to Figure 11-3 for more information about piping requirements and additional parameter adjustments. On Comfort Mode Icon is displayed on local user display. "Aux Pump" output is energized to run a Recirculation pump based on "Aux T'stat" Input (Recirculation enable) terminal status. Off Comfort Mode is disabled.
120°F	60°F - 150°F (16°C - 60°F)	A03 DHW Setpoint Desired DHW temperature produced by boiler.
180°F 83°C	60°F - 190°F (16°C - 88°C)	A04 Central Heat 1 Setpoint Desired water temperature of CH1.
180°F 83°C	60°F - 190°F (16°C - 88°C)	A05 Central Heat 2 Setpoint Desired water temperature of CH2.
0	0, 1	A06 Fuel Gas Selection (visible only after password entered): Boiler is shipped from factory configured for natural gas. Conversion to LP Gas requires 2 steps: • changing this parameter to (1) LP Gas AND • changing gas valve setting from position "1" to position "2". If conversion to LP Gas is required, refer to manual Section 15 Startup and Checkout for complete instructions. (0) Natural Gas (1) LP Gas
0	0	A07 Altitude Selection (visible only after password entered): Boiler is shipped from factory configured for sea level (0 to 2,000 ft. / 0 to 610 m). (0) 0 to 2,000 ft. (0 to 610 m) (1) 2,001 to 6,000 ft. (611 m to 1,828 m) (2) 6,001 to 8,000 ft. (1,829 m to 2,438 m) (3) 8,001 to 10,100 ft. (2,439 m to 3,079 m)
Off	On/Off	A08 Calibrate (visible only after password entered): Setting to "On" enables a manual calibration to be attempted at next boiler start. For immediate calibration cycle CH demand or cycle A01 Burner On/Off Switch. On Manual calibration is requested. Off Manual calibration is not requested.
29	13-46	A09 Gas Valve Offset (visible only after password entered): Gas valve offset is set automatically during calibration. When replacing an old gas valve with a new gas valve, it is possible boiler will not start unless this value is changed. For this situation, set Gas Valve Offset to 30 to allow the boiler to start.
Off	On/Off	A10 Factory Default (visible only after password entered): Returns all parameters back to the original factory default. Must be set after a repair control is installed. On Set all parameter values to Factory Default value. Off No action

16 Operation *(continued)*

Table 16-12: Menu F_r , Firing Rate (visible only after password entered)

Default	Range/ Choices	Parameter and Description
Off	On/Off	<p>$F01$ Manual Modulation Enable</p> <p>Setting to "On" allows technician to fire at rate specified in $F02$. To return to Auto change setting to "Off". Note: Boiler will remain in Manual modulation for 15 minutes after last $F02$ adjustment. After 15 minutes boiler automatically returns to Auto modulation.</p> <p>On Manual</p> <p>Off Auto</p>
100%	0-100%	<p>$F02$ Manual Modulation</p> <p>Firing rate used when $F01$ is set to "On". Note: Manual Modulation will not rise above a specific priority's max modulation or go below minimum modulation. For example, when set to 0%, boiler ramps to minimum modulation and when set to 100% with a CH priority, boiler ramps to CH Max modulation.</p>
136 combi: 80%*	136 combi: 0-80%*	<p>$F03$ Central Heat 1 Max Modulation</p> <p>Defines highest modulation rate during a CH1 demand, Heat T'stat input. If rated input of installed home radiation is less than maximum output of boiler, change $F03$ setting to limit boiler output accordingly.</p>
136 combi (B) 88%*	136 combi (B) 0-88%*	
200 combi: 75%	200 combi: 0-75%	
136 combi: 80%*	136 combi: 0-80%*	<p>$F04$ Central Heat 2 Max Modulation</p> <p>Defines highest modulation rate during a CH2 demand, Aux T'stat input (when selected). If rated input of installed home radiation is less than the maximum output of the boiler, change $F04$ setting to limit boiler output accordingly.</p>
136 combi (B) 88%*	136 combi (B) 0-88%*	
200 combi: 75%	200 combi: 0-75%	
100%	0 - 100%	<p>$F05$ DHW Max Modulation</p> <p>Defines highest modulation rate during a DHW demand.</p>
0%	0 - 30%	<p>$F06$ Minimum Modulation Capacity</p> <p>Increases lowest modulation rate during any call for heat.</p>
0%	136 combi: -9% to +8%	<p>$F07$ Gas Valve Ignition Capacity</p> <p>Increases or decreases gas valve position during burner ignition. For example, increasing this value causes gas valve to be more open (more fuel) during ignition.</p>
	136 combi (B) -9% +8%	
	200 combi: -9% to +3%	
0%	136 combi: -16% to +14%	<p>$F08$ Blower Ignition Capacity</p> <p>Increases or decreases blower speed during burner ignition. For example, increasing this value causes the blower speed to be higher (more air) during ignition.</p>
	136 combi (B) -16% +14%	
	200 combi: -8% to +14%	



* Central Heat 1 Max Modulation ($F03$) and Central Heat 2 Max Modulation ($F04$) default and range increased to 100% for 136 combi above 2,000 ft. (305 m) to help recover de-rate associated with altitude.

16 Operation *(continued)*

Table 16-13: Menu 5P, Setpoint Menu (visible only after password entered)

Default	Range/ Choices	Parameter and Description	
0	0, 1	50 Temperature Units	
		Sets display temperature in degrees Fahrenheit or Celsius.	
		(0) Fahrenheit	(1) Celsius
60	0 to 120 (minutes)	502 DHW Priority Time	
When DHW Priority Time is greater than zero and DHW heat demand is present, DHW demand has priority over heating demands for this specified time. After DHW demand ends or DHW Priority Time is exceeded and CH demand is present, CH demand has priority over DHW demand.			
130°F 54°C	50°F to 180°F (10°C to 83°C)	503 Central Heat 1 Min Boiler Water Temp	
Sets a low limit for Reset setpoint. Set this parameter to lowest supply water temperature that will provide enough heat for type of radiation used to function properly. Always consider type of radiation when adjusting this parameter.			
130°F 54°C	50°F to 180°F (10°C to 83°C)	504 Central Heat 2 Min Boiler Water Temp	
Sets a low limit for Reset setpoint. Set this parameter to lowest supply water temperature that will provide enough heat for type radiation used to function properly. Always consider type of radiation when adjusting this parameter.			
2	0, 1, 2	505 Auxiliary Thermostat Input Select:	
		May be used as "Recirculation Enable", "Indirect Water Heater (IWH) DHW demand" (heating boilers only) or "CH Zone 2 Heat demand" input.	
		(0) Recirculation Enable	Recirculation enable input. When Recirc (Comfort) Mode is enabled, "Aux Pump" output is energized to run a recirculation pump when this input is "On". This input may be (a) jumpered allowing recirculation pump to run at all times, (b) wired to a time of day clock, or (c) wired to a momentary push button. Note: recirculation pump continues to run for 15 minutes after this input is removed.
		(1) DHW Demand	Indirect Water Heater (IHW) DHW heat demand. (not for combi boilers)
(2) CH Zone 2 Thermostat	Central Heat 2 heat demand.		

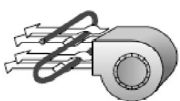
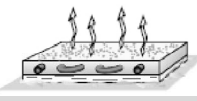
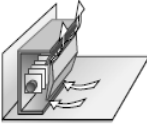
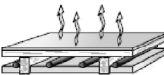
Table 16-14: Radiation Setpoints

Central Heat Setpoint	Heating Element Type		Central Heat Setpoint	Heating Element Type	
180°F to 190°F (82.2°C to 87.8°C)	Fan Coil		100°F to 140°F (37.8°C to 60°C)	In Slab Radiant High Mass Radiant	
160°F to 190°F (71.1°C to 87.8°C)	Convection Baseboard Fin Tube Convective		130°F to 160°F (54.4°C to 71.1°C)	Staple-up Radiant Low Mass Radiant	
130°F to 160°F (54.4°C to 71.1°C)	Radiant Baseboard		140°F to 160°F (60°C to 71.1°C)	Radiators	

16 Operation *(continued)*

Table 16-15: Menu PU, Pump Menu (visible only after password entered)

Default	Range/ Choices	Parameter and Description	
2	1, 2, 3	P01 System Pump Output Select: Activates System Pump output according to selected function.	
		(1) System Pump Any Demand:	Pump Runs during any call for heat.
		(2) System Pump Central Heat:	Pump Runs during CH1 and CH2 demand. Pump does not start for a DHW demand and will be forced off if there is a DHW demand and DHW Priority is active.
		(3) Zone 1 Pump, CH Zone 1 Only:	Pump runs during CH1 demand. Pump does not start for CH2 or DHW demand. Pump will be forced off when DHW priority is active. This option allows System Pump output to be used as a zone pump.
1	1, 2, 3	P02 Boiler Pump Output Select: Activates Boiler Pump output according to selected function.	
		(1) Boiler Pump Any Demand:	Pump runs during any call for heat. Pump also runs when it is Sequencer lead pump.
		(2) Boiler Pump Header Sensor Demand:	Pump runs when boiler is firing and when there is a DHW heat demand. Selected when Header Sensor is selected as CH1 and CH2 modulation sensor, and boiler is a stand-alone boiler.
		(3) Boiler Pump CH Only, Off for DHW:	Pump runs during CH1, CH2 and CH frost protection demand and will be forced off if there is a DHW demand and DHW priority is active. This function is selected when there is a direct piped IHW installed with a dedicated DHW pump.
4	1, 2, 3, 4	P03 Auxiliary Pump Output Select Activates Auxiliary Pump output according to selected function.	
		(1) Recirculation Pump:	Pump runs when Recirc (Comfort) Mode selected, recirculation sensor installed and Aux T'stat enabled (jumper installed, optional Recirculation Timer On or after optional Point of use button pressed.) Note: Recirculation pump remains running 15 minutes after Aux T'stat input removed.
		(2) DHW Pump Primary Loop Piped IHW:	Pump Runs during DHW demand. DHW Priority enable/disable does not affect pump operation. [Not for Combi boilers]
		(3) DHW Pump Boiler Piped IHW:	Pump runs during DHW demand. Pump is forced off during CH demand when 1) DHW priority is disabled or 2) DHW priority is enabled and DHW demand has remained on for longer than Priority Time. [Not for Combi boilers]
		(4) Zone 2 Pump CH Zone 2 Only:	Pump runs during CH2 call for heat. Pump does not start for CH1 or DHW demand. The pump will be forced off when DHW priority is active. This allows the Aux Pump output to be used as a zone pump.

16 Operation *(continued)*

Table 16-16: Menu LL, Lead Lag Menu (visible only after password entered)

Default	Range/ Choices	Parameter and Description
Off	On/Off	L01 Lead Lag Master Enable [Not for Combi boilers] Used to "turn on" Multiple Boiler Controller On Sequencer Master is Enabled. Off Sequencer Master is Disabled.
0	1 through 8	L02 Lead Lag Slave Address Each boiler must be given a unique address, address determines boiler start order.
Off	On/Off	L03 Lead Lag Outdoor Reset [Not for Combi boilers] If an outdoor sensor is installed and Lead Lag Outdoor Reset is Enabled, boiler will automatically adjust heating zone set point temperature based on outdoor reset curve. On Enable, calculate temperature setpoint based on outdoor temperature using a reset curve defined by Low Outdoor Temp, High Outdoor Temp, Min Boiler Temp and CH Setpoint and Boost Time parameters Off Disable, do not calculate setpoint based on outdoor temperature.

Table 16-17: Menu 2P, Zone Panel Menu (visible only after password entered and panel is connected)

Default	Range/ Choices	Parameter and Description
Off	On/Off	201 to 216 Zone 1-16 On/Off Status (Individual Zones Only Visible when communicating zone panel zone is detected.)
0	0 - 999,999	217 to 232 Zone 1-16 cycle count (Individual Zones Only Visible when communicating zone panel zone is detected.)

16 Operation *(continued)*

This section covers control features available via local display. For additional control features available via our App, see Extended Features Manual available on our website or in our App.

Control System Overview

The control manages all of the following boiler functions:

1. **Boiler Control**
Control simultaneously modulates blower speed and gas valve position to control firing rate and sequences up to three pumps and a 3 way valve to respond to DHW and CH demands.
2. **Flame Supervision/Air-Fuel Ratio Control**
Control is a "Gas-Adaptive system" that regulates air and gas flow mixture by measuring flame signal and adjusting gas valve to achieve target air fuel ratio. This eliminates need to make throttle screw or offset adjustments. This system is self-calibrating and continuously maintains air fuel ratio at desired value.
3. **Domestic Hot Water**
DHW demand is detected by a DHW flow sensor. When a DHW draw greater than 0.5 gpm is detected, control diverts all boiler water flow through plate heat exchanger, starts boiler pump and modulates firing rate based on measured DHW temperature and DHW set-point. When there is a DHW demand, system pump will be turned off, boiler services only DHW. Priority protection is provided to ensure heating system is also serviced.
4. **DHW Recirculation**
When "Recirculation (Comfort) Mode" is selected (from Quick Menu A) a recirculation sensor and auxiliary thermostat input are monitored and a recirculation pump is controlled via aux pump terminals in order to maintain a warm DHW loop. Recirculation can reduce time needed for hot water to appear at a fixture. Refer to internal wiring diagrams Figures 20-1 and 20-2 for recirculation pump and sensor connections and piping diagram Figure 11-3 for recommended piping layout.
5. **Central Heat**
CH demand is detected by a heating thermostat call for heat. When CH demand is detected, control diverts all boiler water to CH zones, starts boiler pump and modulates firing rate based on measured supply sensor and CH setpoint. When DHW recirculation is not used control can accept a second heating thermostat wired to the Aux T'stat input. CH demands have separate setpoint and maximum modulation rates.
6. **Sensorless Reset**
Control system monitors recent firing rate and burner cycle data to infer current building heat loss. Target supply water temperature is then adjusted to match this heat load. No outdoor sensor mounting or wiring is required. Boost feature increases operating temperature setpoint by 10°F (5.6°C) every 20 minutes CH demand is not satisfied. This process will continue until heat demand is satisfied (indoor air is at desired temperature), or CH setpoint is reached. Once heat demand is satisfied, operating setpoint reverts to value determined by the Outdoor Reset settings.
7. **Pump Exercise**
Connected pumps are automatically run for a 20 second exercise period after not being used for longer than 7 days. This helps prevent pump rotor seizing.
8. **Pump Air Elimination (Pump Purge)**
Pump purge is entered when power is cycled or when there has been an over temperature hold. During this state boiler pump and three way valve cycle in sequence for two minutes to help remove air from boiler water piping. This may be interrupted by pressing the  **reset** button.
9. **Built-in Safety Control**
Control includes functions designed to ensure safe and reliable operation. In addition to flame supervision, control monitors supply water temperature, differential water temperature, and flue temperature safety limits. Boiler modulation is adjusted when required to help avoid loss of boiler operation due to exceeding limits. Additionally, control accepts field installation of external limits.
10. **Fuel Conversion**
The conversion from Natural Gas to LP Gas (or vice versa) is made by changing gas valve setting and a control parameter change on display.
11. **Compatible with Multiple Boiler Sequencer**
The control is compatible with multiple boiler sequencer peer-to-peer networks. Control can be connected to up to eight (8) boilers using RJ45 Ethernet cable. Combi goes "on leave" from network when DHW demand is present.

16 Operation *(continued)*

12. Priority Demand

Control accepts a call for heat from multiple places and responds to its "Priority". When more than one demand is present, higher priority demand is used to determine active boiler settings. For example, when DHW has priority, setpoint, "Diff Above", "Diff Below" and pump settings are taken from DHW selections. Active "Priority" is displayed on the Diagnostic Menu, item "E02", see Table 16-9.

Table 16-18: Order of Priority

E02	Boiler Responding to:
1st	Domestic Hot Water
2nd	Sequencer Control Connected to the peer-to-peer network.
3rd	Central Heat 1 CH1 call for heat is on and there is no DHW demand or DHW priority time has expired.
4th	Central Heat 2 CH2 call for heat is on and there is no Central Heat 1 or DHW demand.
5th	Frost Protection Frost Protection is active and there is no other call for heat. Frost protection will be a higher priority than Sequencer Control if the Sequence Master has no active call for heat.
6th	Urgent Calibration Performed because of no regular CH demands and boiler is cold.
7th	Boiler Switch "On/Off" When Boiler Switch is set to "Off" position the boiler does not respond to any demands.

Boiler Protection Features

- Supply Water Temperature High Limit**
 Control is equipped with internal operating control and high limit features. Control monitors a dual element temperature sensor that is UL353 and UL1998 listed. If supply water temperature increases above the active setpoint plus diff above, (default 190°F [87.7°C]) boiler is cycled off. If temperature exceeds 210°F (98.9°C), a manual reset hard lockout results. If boiler is responding to internal Multiple Boiler Control Sequencer, Header Sensor or an External EMS demand and supply water temperature increases above 190°F (87.7°C) control begins to reduce the blower maximum speed setting and if the temperature increases to 200°F (93°C) a forced recycle results.
- High Differential Temperature Limit**
 Control monitors temperature difference between return and supply sensors. If this difference exceeds 58°F (32°C) control begins to reduce blower maximum speed and if temperature difference exceeds 63°F (35°C) a forced boiler recycle results. Boiler will restart automatically once temperature difference has decreased and minimum off time has expired.
- Return Temperature Higher Than Supply Temperature (inversion Limit)**
 Control monitors supply and return temperature sensors. If return water temperature > supply water temperature for longer than a limit time delay control shuts down and restarts boiler and delays. If inverted temperature is detected more than five times, boiler manual reset Hard Lockout is activated.
- External High Limit**
 An external limit control can be installed on low voltage connections terminal strip. Be sure to remove jumper when adding an external limit control to system. If external limit opens, the boiler will shut down and an open limit indication and error code is provided. If limit installed is a manual reset type, it will need to be reset before boiler will operate.
- External (LWCO)**
 An external LWCO control (optional) can be installed on the low voltage connections terminal strip 24 VAC LWCO connection. If the LWCO opens, boiler will shut down and an open limit indication and error code is provided. If LWCO installed is a manual reset type, it will need to be reset before boiler will operate.
- Boiler Mounted Limit Devices**
 Control monitors thermal fuse (top of heat exchanger) and boiler water flow switch. If either of these limits open while the boiler is running, boiler will shut down and a fault indication is provided. Additionally, control monitors an air pressure switch. During boiler start sequence, control requires the air pressure switch to be in "open" position before blower starts and in "closed" position after blower starts. If this does not happen, start sequence is halted and fault indication is provided. Air pressure switch is only required to be closed during pre-purge. It is normal for the air proving switch to be open during run mode.

16 Operation *(continued)*

Boiler Protection Features *(continued)*

7. **Flue High Limit**
Control monitors flue temperature sensor located at top of heat exchanger. If flue temperature exceeds 194°F (90°C), control begins to reduce blower maximum speed and if flue temperature exceeds 204°F (96°C), a forced boiler recycle results. If flue temperature exceeds 214°F (101°C), control activates a manual reset Hard Lockout.
8. **Raised Minimum Modulation**
To help prevent nuisance shutdowns following a loss of flame while the boiler is running, (condition that could be caused by excessive wind) minimum modulation is increased to help prevent additional nuisance shutdowns. Minimum modulation increase is removed after an hour.
9. **Calibration**
The control measures flame signal during burner operation to ensure a constant air fuel ratio. An accurate flame signal measurement is maintained over time by periodically calibrating flame signal measurement.

Normal calibration is performed during CH demand. When there is no CH demand (non-heating seasons) calibration is periodically initiated when boiler is cold and no demand is present.
10. **Ignition Failure**
Control monitors ignition using a burner mounted flame sensor. In event of an ignition failure, the control retries 2 times and then goes into soft lockout for one hour. After a one hour soft lockout control will retry 2 additional times before control activates a manual reset Hard Lockout.
11. **Central Heating System Frost Protection**
Frost Protection starts boiler and system pump and fires boiler when low outdoor air, low supply water or Low DHW temperatures are sensed. Control provides following control action when frost protection is enabled:

Table 16-19: Frost Protection Interlocks

Device Started	Start Temperatures	Stop Temperatures
Boiler Pump	Outdoor Air < 0°F (-18°C) Supply Water < 45°F (7.2°C) DHW Water < 45°F (7.2°C)	Outdoor Air > 4°F (-16°C) Supply Water > 50°F (10°C) DHW Water > 50°F (10°C)
Boiler	Supply Water < 38°F (3.3°C) DHW Water < 38°F (3.3°C)	Supply Water > 50°F (10°C) DHW Water > 50°F (10°C)

NOTICE: FROST PROTECTION

The control helps provide freeze protection for boiler water. Boiler flue gas condensate drain is not protected from freezing. Frost protection only controls system and boiler pumps. Individual zones are not protected. It is required that boiler be installed in a location that is not exposed to freezing temperatures. Outdoor air interlocks included when outdoor air sensor is wired to low voltage terminal block.

WARNING

Burn Hazard.

- Boiler may start without DHW or CH demands when periodic calibration is required and boiler is cold. (Supply temp. < 95°F (35°C))
- Boiler can continue to run after demand is removed in order to complete calibration sequence

17 Before Leaving Jobsite

Before leaving jobsite:

- Installed ASSE 1017 or 1070 tempering valve
- Installed wall retaining clips (bottom)
- Flushed heating system
- Boiler and system filled with water
- Air purged from boiler system
- No loose, uninsulated or miswired connections
- Checked for gas leaks
- Checked gas inlet pressure
- Closed gas inlet pressure tapping
- Performed combustion test
- Screw cap in vent adapter
- No errors or holds present on display, clear recent error codes
- Tested additional field installed controls for functionality outlined by manufacturer (i.e. LWCO, high limit, or other controls)
- Set proper CH temperature setpoint
- Set proper DHW temperature setpoint
- Tested DHW operation to confirm tempering valve setting
- Verify system pump operation
- Adjusted heating thermostat to its final setpoint
- Checked all valve and control settings
- Reviewed User's Information Manual and system operation with owner/operator

18 Service and Maintenance

Important Product Safety Information: Refractory Ceramic Fiber Product

WARNING

Some boiler components use materials that contain refractory ceramic fibers (RCF). RCF has been classified as a possible human carcinogen. When exposed to elevated temperatures, RCF may change into crystalline silica, a known carcinogen. When disturbed as a result of servicing or repair, these substances become airborne and, if inhaled, may be hazardous to your health. Avoid breathing RCF particulates and dust.

Precautionary Measures:

- Do not handle RCF parts or attempt any service or repair work involving RCF without wearing the following protective gear:
 1. A properly fitting National Institute for Occupational Safety and Health (NIOSH)-certified air-purifying respirator with a filter efficiency of at least 95%. Respirator should also include a full facepiece when handling used RCF. Other types of respirators may be required depending on site conditions. Current NIOSH recommendations may be found on the NIOSH website <http://www.cdc.gov/niosh/homepage.html>. NIOSH-approved manufacturers, respirators and associated user instructions are listed on the NIOSH website.
 2. Long sleeved, loose fitting clothing that is sufficiently tight around potential entry points for RCF dust.
 3. Gloves.
 4. Eye protection, such as goggles, safety glasses with side shields, or full facepiece.
- Take steps to assure adequate ventilation.
- Handle RCF carefully to minimize airborne dust. Use hand tools whenever possible.
- Dampen used RCF with light water spray prior to removal to prevent airborne dust.
- Do not use compressed air or dry sweeping for clean-up. Frequently clean work area with a vacuum or by wet sweeping to minimize debris accumulation.
- Vacuum work clothes before leaving work area. Wash work clothes separately from other laundry and rinse washing machine after use to avoid contaminating other clothes.
- Wash all exposed body areas gently with soap and water after contact.
- Discard used RCF components by sealing in an airtight plastic bag or container. Refer to local, regional, state or provincial regulations to identify applicable disposal requirements.

First Aid Procedures:

- Eye contact: Flush with water for at least 15 minutes. **Do not rub eyes.** Seek immediate medical attention if irritation persists.
- Skin contact: Wash affected area gently with soap and water. Do not rub or scratch affected skin. Seek immediate medical attention if irritation persists.
- Nose and throat contact: If these become irritated, leave the area and move to a location with clean fresh air. Drink water and blow nose. Seek immediate medical attention if symptoms persist.

18 Service and Maintenance *(continued)*

WARNING

Asphyxiation Hazard. Fire Hazard. Explosion Hazard.

- This boiler requires regular maintenance and service to operate safely.
- Improper installation, adjustment, alteration, service or maintenance could result in severe personal injury, death or substantial property damage. Read and understand this entire manual before attempting installation, start-up operation, or service. Installation and service must be performed only by a qualified installer, service agency or gas supplier.
- Read all instructions contained in component manufacturer's manuals before installing, starting up, operating, maintaining or servicing.

DANGER

Explosion Hazard. Electrical Shock Hazard. Burn Hazard.

This boiler uses flammable gas, high voltage electricity, moving parts, and very hot water under high pressure. Assure that all gas and electric power supplies are off and that the water temperature is cool and system is depressurized before attempting any disassembly or service. Do not rely solely on temperature/pressure gage to make this determination.

WARNING

Burn Hazard.

- Never jump out or bypass any safety or operating control or component of this boiler.
- All cover plates, enclosures and guards must be in place when boiler is left in operation.

NOTICE: Warranty does not cover boiler damage or malfunction if the following steps are not performed at the intervals specified.

Continuously:

1. Keep area around boiler free of combustible materials, gasoline and other flammable vapors and liquids.
2. Keep area around combustion air inlet terminal free from products containing chlorine, chloride based salts, chlorofluorocarbons, paint removers, cleaning solvents, or detergents.
3. Keep the boiler room ventilation openings open and unobstructed.

Monthly Inspections:

1. Inspect vent piping and air intake piping to verify it is free from leakage and deterioration. Also verify vent and air intake terminals are unobstructed.
2. Inspect condensate drain system to verify it is water tight, and unobstructed.
3. Inspect water and gas lines to verify they are free from leaks.

If above inspections reveal potential problems, contact a service agency immediately to further inspect and repair if necessary.

Annual Inspections and Service:

In addition to inspections listed above, the following should be performed by a service technician once every year.

1. **Before inspecting boiler components**
 - A. Follow procedure for turning boiler off found in Lighting and Operating Instructions. (Figure 15-10).
 - B. Turn off all power to boiler.
 - C. Inspect wiring to verify conductors are in good condition and attached securely.

WARNING

Electrical Shock Hazard.

Label all wires prior to disconnection when servicing controls. Wiring errors could cause improper and dangerous operation. Verify proper operation after servicing.

- D. Verify gas shutoff valve at boiler is closed.
2. **Before servicing gas train components**
 - A. Disconnect air proving switch tube from gas valve outlet adapter tap.
 - B. Unplug power and speed control cables from blower.
 - C. Unplug ignition and ground wires from ignitor/flame sensor.
 - D. Loosen nut on top of gas valve (1-1/8 in. wrench).
 - E. Use a 10 mm wrench to remove four nuts securing burner door to heat exchanger (Figure 18-1). Carefully remove door/blower, being careful not to damage the refractory insulation on inside of door (see Refractory warning) or ignitor/flame sensor.

18 Service and Maintenance *(continued)*

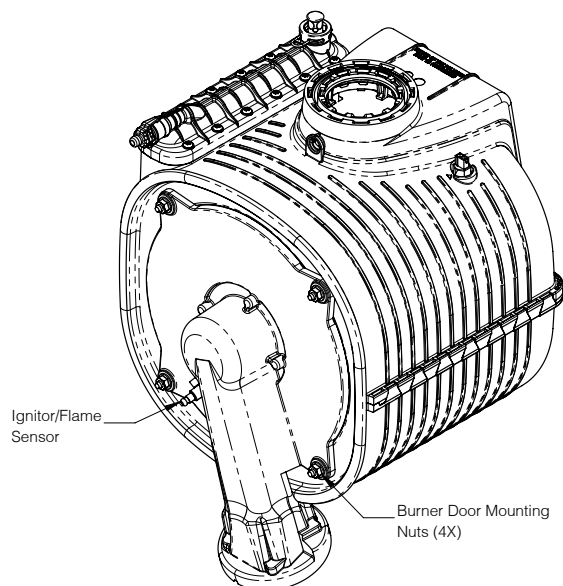

Figure 18-1: Ignitor/Flame Sensor Location

3. **Inspect heat exchanger combustion chamber.**
Vacuum any debris found on coil surfaces. If further cleaning is necessary, use heat exchanger cleaning kit (111705-01). Water and vinegar are acceptable cleaning agents. Do not use any other cleaning agents, solvents, acid, or alkali products of any kind to clean heat exchanger.
4. **Inspect target wall and burner door insulation.**
If either shows signs of damage, it must be replaced.
5. **Inspect burner door seal.**
Look for signs of embrittlement or deterioration. Replace if needed.
6. **Inspect burner.**
Look for heat damage or other deterioration. Use a nonmetallic brush or source of compressed air to clean off dust or debris from ports. Ensure burner is secured tightly to burner door.

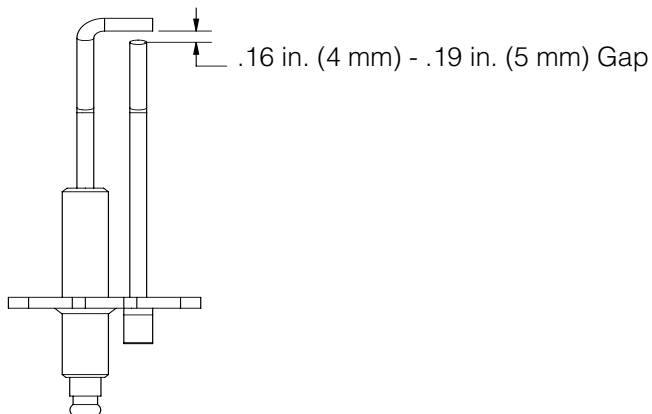

Figure 18-2: Ignitor/Flame Sensor Spark Gap

7. **Inspect ignitor/flame sensor.**
 - A. Clean off any deposits found with steel wool. Do not use sand paper or Emory cloth for this cleaning.
 - B. Inspect ceramic portion for cracks and replace ignitor/flame sensor if any are found.
 - C. Verify ignitor/flame sensor spark gap is within range shown in Figure 18-2.
 - D. Verify gap between ignitor/flame sensor and burner is within range shown in Figure 18-3 and Table 18-4.

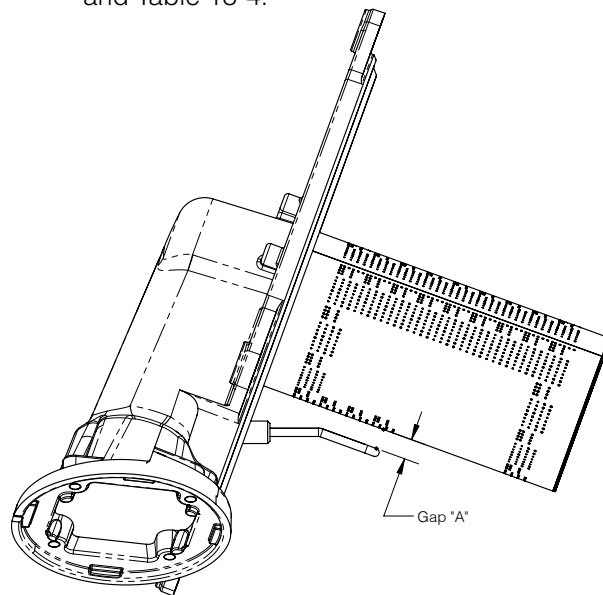

Figure 18-3: Ignitor/Flame Sensor to Burner Gap

Table 18-4: Electrode Gap

Boiler Size	Gap A
136 combi	.32 in. (8 mm) - .52 in. (13 mm)
136 combi (B)/ 200 combi	.36 in. (9 mm) - .56 in. (14 mm)
200 combi	(LP above 2,000 ft. (610 m)) .59 in (15 mm) - .79 in. (20 mm)

8. **Inspect blower gas valve assembly.**
 - A. Look for dust, lint, or other debris that may have been drawn into this assembly. Excessive deposits may be vacuumed out.
 - B. Inspect all rubber and plastic components on blower/gas valve assembly, looking for deterioration. Replace blower and/or gas valve if deterioration is found.

18 Service and Maintenance *(continued)*

9. Inspect and clean condensate trap.

- Place bucket under condensate clean out cap on bottom of boiler (Figure 18-5) to catch water in trap as well as ball and support.
- Unscrew cap, being careful not to lose ball or ball support.
- Flush any debris found in trap with water - do not use other cleaning agents. Reassemble trap as shown in Figure 18-5.

WARNING

Asphyxiation Hazard.

Do not operate boiler without condensate trap ball and ball support in place. Doing so could cause products of combustion and or carbon monoxide to enter building resulting in severe personal injury, death or substantial property damage.

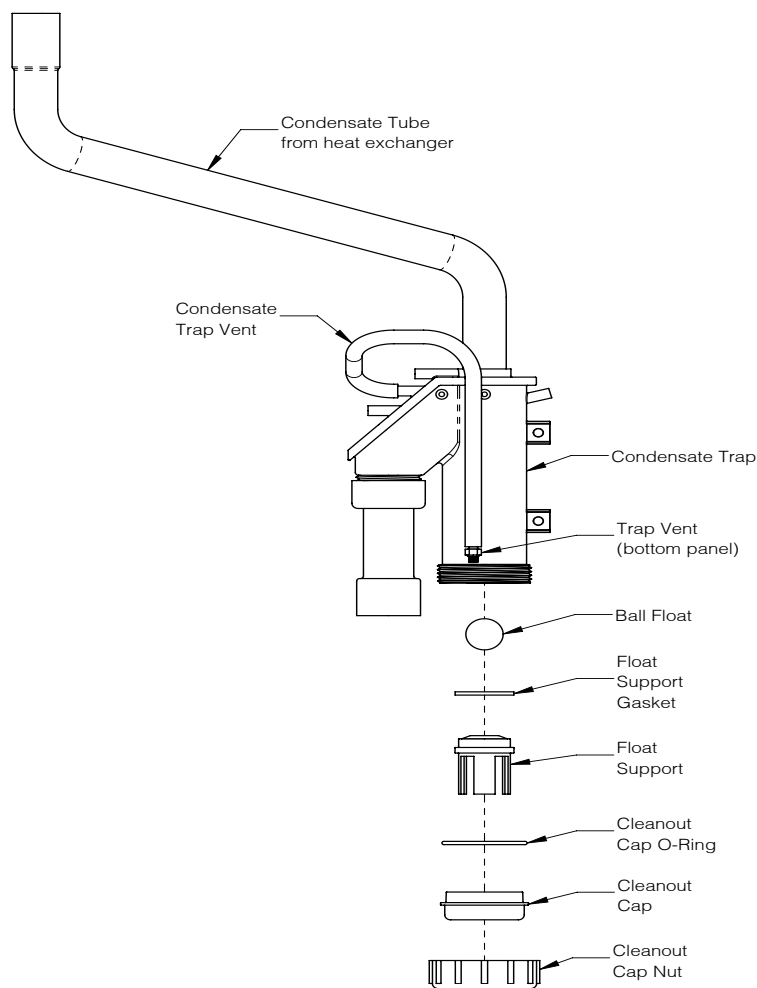

Figure 18-5: Condensate Trap Exploded Parts View

NOTICE: Attempting to clean heat exchanger or trap with anything other than water or vinegar could damage heat exchanger or result in condensate backup, causing boiler to shut down.

10. Reinstall burner door/blower assembly.

Follow above steps in reverse order.

WARNING

Component Damage.

Do not over tighten burner door mounting nuts. Doing so could break burner door mounting studs. If any of these studs is damaged, heat exchanger must be replaced. Use of a short 10 mm box wrench will reduce risk of damaging these nuts.

11. Inspect vent system.

- All gaskets and joints between boiler heat exchanger and terminal are leak tight.
- All supports are intact and vent system is properly pitched.
- All pipe is in good condition. Look for damage such as cracks, heat distortion, and embrittlement. If any such damage is found, pipe must be replaced and cause of damage identified.
- Vent/air terminals are in good condition, free from blockage and still correctly located relative to doors, windows, decks, etc.

18 Service and Maintenance *(continued)*

- E. Refer to Sections 7 thru 9 to re-assemble any vent system components that are disassembled during this inspection and for details on supporting, pitching and terminating vent system.

12. Inspect hydronic system and DHW piping.

- A. Look for leaks and repair if found. If system contains antifreeze, or other additives, test and/or maintain them as directed by additive manufacturer.
- B. Test heating system and DHW inlet water quality to ensure they meet minimum requirements specified in Section 15 Start-Up and Checkout and Section 11 Domestic Water Piping.
- C. Inspect DHW flow limiter. Clean any debris/build up, replace if necessary.
- D. If DHW cold water supply is equipped with a water filter replace according to manufacturer's recommendations.
- E. Refer to Appendix B for important information on quality and boiler additives.

13. Flush plate heat exchanger.

Back-flush (against normal flow) DHW loop to remove scaling. Vinegar can be used to help remove deposits.

14. Inspect safety relief valve.

WARNING

Explosion Hazard.

Safety relief valves require periodic maintenance. Refer to relief valve manufacturer's instructions for frequency and proper procedure. Any testing or maintenance shall be done by a qualified installer, service agency or gas supplier.

15. Place boiler back into operation.

- A. Replace any wiring which has been disconnected.
- B. Perform visual inspection of gas piping to ensure no inadvertent damage to gas train components during servicing.
- C. Follow all instructions in Section 15 Start-Up and Checkout to place boiler back in service, including performance of combustion test.

16. Test boiler flow switch.

- A. Start with boiler in standby.
- B. Either close a shut off in boiler loop or unplug boiler pump at connector.
- C. Initiate a call for heat and confirm that boiler shows an Active Fault (H05) indicating flow switch is open.

WARNING

Component Damage.

If burner comes on with no flow through boiler, there is a problem with flow switch. Turn boiler off immediately. Failure to do so could result in severe heat exchanger damage.

- 17. **Assure that all safety and operating controls and components are operating properly before placing boiler back in service.**









19 Troubleshooting

WARNING

Electrical Shock Hazard. Turn off power to boiler before working on wiring.

A. Troubleshooting with No Active Fault Code Displayed

Table 19-1: Troubleshooting with No Active Fault Code

Indication	Possible Causes	Corrective Action
Display Completely Dark And Fan Off	No 120 VAC supplied to boiler.	Check breaker and wiring between breaker panel and boiler.
Display Completely Dark, Fan Running	Blown T1.0 A Fuses (supplies power to control).	Check T1.0 A Fuse, replace with a 1 Amp, 250V, Slow Blow, 5x20 mm if necessary.
	Loose blower wiring.	Check blower wiring connections, correct if necessary.
	Defective control.	Replace control.
Boiler Not Responding To Call For  Heat, Icon Is Off	 Boiler On/Off Switch is "Off", (Status ).	Switch Quick Menu Item  , Boiler On/Off Switch, "On".
	Remote thermostat is satisfied.	Check remote thermostat setting.
	Loose thermostat wiring.	Check thermostat wiring, correct if necessary.
	Blown T0.5A Fuse (supplies power to thermostats).	Check T0.5 A Fuse, replace with a 0.5 Amp, 250V, Slow Blow, 5x20 mm if necessary.
Boiler Not Responding to Call For  Heat, Icon is On	Boiler is in standby, (Status ), temperature is above setpoint.	Check temperature setpoint setting.
	Faucet icon is on	Servicing DHW demand.
	Boiler is in Warm Weather Shutdown, (Status ).	Feature available with PAT-Connect Bluetooth Adaptor and App.
No Central Heat, Boiler Runs	Defective 3-way valve.	Check 3-way valve, replace if necessary.
	Defective 3-way valve wiring.	Check wiring to 3-way valve, correct if necessary.
	Recirculation piping problem.	Recirculation sensor does not detect flow. Check piping. See Figure 11-3.
Boiler Running But System Or Auxiliary Pump Not Running	Pump setting is incorrect.	Switch  Menu Item  , System Pump Selection. Refer to Table 16-15.
	Loose wiring to pump	Check pump wiring, correct if necessary.
	Defective pump.	Replace pump.

19 Troubleshooting *(continued)*

Table 19-1: Troubleshooting with No Active Fault Code (continued)

Indication	Possible Causes	Corrective Action
Water At Shower Or Faucet Is Cold	Draw rate exceeds combi's rated capacity.	Verify draw rate and temperature rise are both at or below ratings shown in Table 3-1.
	Draw rate below combi's rated capacity.	Verify draw rate is above rating shown in Table 3-1.
	DHW flow limiter is dirty or clogged.	Verify there is no debris or build up in flow limiter and clean if present. Replace if necessary.
	Defective 3-way valve.	Check 3-way valve can respond to CH and DHW demands and has desired effect on water flow, replace if necessary.
	Defective 3-way valve wiring.	Check 3-way valve wiring. Correct if necessary.
	Defective tempering valve.	Check tempering valve (field supplied) by adjusting valve and observing output, replace if necessary.
	Tempering valve adjustment required.	Check setting on tempering valve (field supplied).
	Control DHW setpoint too low.	Press + / - Display buttons to adjust DHW setpoint.
	Defective DHW Flow Sensor	Check DHW Flow Sensor is functioning properly.
	Plate heat exchanger dirty.	Check plate heat exchanger performance and back flush if necessary. Replace if back flushing does not improve performance.
Recirculation (Comfort) Mode is used and Recirculation Pump is not On.	Recirculation pump is turned Off when calibration is required. Pump operation will continue after a calibration.	
Boiling, Kettling, or Water Hammer	Low Water flow through plate heat exchanger.	Remove and inspect plate heat exchanger, flush heat exchanger if required.
	Air in system.	Cycle boiler power to initiate pump air elimination function. Air is removed from boiler loop when there are no "air noises" in the heat exchanger.
	Low system water pressure.	Check boiler water pressure, adjust feedwater as necessary.
Rough ignitions	Insufficient gas supply pressure.	Refer to Table 3-5 for required pressure range.
	Dirty or defective burner.	Refer to Section 18 Service and maintenance for proper procedure to check burner. Replace if necessary.
	Dirty or damaged ignitor/flame sensor	Check ignitor/flame sensor gap and distance to burner. See Figure 18-2 and Table 18-3 for distance specification Replace ignitor/flame sensor if necessary.
Relief Valve Opening	System pressure exceeds relief valve setting.	Lower system water pressure below rating of supplied safety relief valve.
		Replace standard safety relief valve with higher rated valve up to the maximum pressure of the heat exchanger. 50 psig (345 kPa)
		Improperly sized expansion tank.

19 Troubleshooting *(continued)*

In the event of high CO (CO air free greater than 200 ppm for 0-2,000 ft. (0-610 m) or greater than 300 ppm for above 2,000 ft. (610 m)) follow below steps in specified order:



1. Confirm fuel settings (see Section 15 Start-up and Checkout)
 - A. Gas valve setting (1) for Natural Gas, (2) for LP
 - B. Control fuel gas selection [R05] (0) for Natural Gas, (1) for LP
 - C. Control altitude selection [R07] for
 - (0) 0 to 2,000 ft. (0 to 610 m)
 - (1) 2,001 to 6,000 ft. (611 to 1,828 m)
 - (2) 6,001 to 8,000 ft. (1,829 to 2,438 m)
 - (3) 8,001 to 10,100 ft. (2,438 to 3,079 m)
 - D. Confirm 200 combi LP electrode change (brown colored electrode) for installations above 2,000 ft. (610 m).
2. Perform manual calibration 5 times per Table 16-11 [R08].
3. Follow instructions in Section 18 Service and Maintenance to
 - A. Check integrity of burner. Replace if necessary.
 - B. Check ignitor flame sensor distance to burner per Figure 18-3.
4. Consult manufacturer.

19 Troubleshooting *(continued)*

B. Troubleshooting with Status Numbers

In Operating Mode, use arrow keys ("↑" or "↓") to reach "5LR". Display will then alternate between "5LR" and number shown below.

Table 19-2: Status Number Explanation

Display	Description	Explanation
0	Self Check	When first powered up control performs an internal check that takes approximately 10 seconds.
1	Standby	No burner demand is present. This could be because there is no call for heat or because temperature has exceeded set point plus differential. If there is heating demand, pump(s) will run in standby.
2	Waiting For Air Pressure Switch To Close	When a burner demand appears, blower starts and waits for the air pressure switch to close, proving air flow.
3	Prepurge	Once air flow is proven, blower runs for a defined period of time (less than 10s) before attempting burner ignition.
4	Burner Ignition	System is lighting burner and allowing flame to stabilize after ignition.
5	Calibration	Control system checks to confirm it is properly controlling air fuel ratio. This happens when boiler is initially powered up and periodically thereafter. When calibration is required, system checks flame signal at both intermediate input and at low fire. This calibration process takes approximately 1 minute and is normally done during a CH demand.
6	Low Fire Hold	Burner is being driven to low fire immediately following ignition for a short period of time to minimize likelihood of temperature overshoot if heating load is too small.
7	Rate Limit	Firing rate is being limited due to an abnormal condition, such as: <ul style="list-style-type: none"> • High supply water temperature, • High differential water temperature, • High flue temperature, • Raised minimum modulation due to loss of flame during run H24.
8	Run (Modulate)	Burner is on and is being allowed to freely modulate to match the heating load.
9	Postpurge	Blower runs for a defined period after burner shutdown to clear combustion products from boiler and vent system.
10	Pump Air Elimination	When the boiler is first powered up, boiler pump and 3-way valve are cycled for 2 minutes to remove air from boiler. Pump air elimination also occurs after there has been an over temperature Hold. This process may be interrupted by pressing:  reset button.
11	Standby Delay	Boiler is in hold status and boiler is not running and hold code is stored in history b menu. Boiler will automatically restart once condition that caused Hold is corrected. Refer to Table 19-5 for hold code name, possible causes and corrective action.
12	Lockout	When lockout occurs, boiler will shut down and event is stored in history, b, menu. Once condition that caused the lockout is corrected, boiler remains shut down until a reset has been performed by pressing:  reset button. Refer to Table 19-5 for lockout code name, possible causes and corrective action.
13	Boiler On/Off Switch (RO I)	Burner and pumps have been switched off by parameter, control is disabled via Quick Menu item RO I.
14	Warm Weather Shutdown	When Warm Weather Shutdown is enabled, boiler and pumps are prevented from responding to a CH demand. Boiler and pumps are free to respond to a DHW demand. Feature available with PAT-Connect Bluetooth Adaptor and App.

19 Troubleshooting *(continued)*

C. Troubleshooting with Diagnostic Codes

In Diagnostic and Quick Menu Mode, use the arrow keys ("↑" or "↓") to reach "ε" menu and press "enter" button to view diagnostic codes.

Table 19-3: Diagnostic Menu

Display	Name	Description
ε 01	Active Detailed Fault Code	Control has an extensive fault code system with corrective actions defined. If a fault code exists, it should be first place to look for diagnosing a problem. Refer to Table 19-6 for detailed code condition description.
ε 02	Demand Source 1 Standby 2 Central Heat 1 3 Central Heat 2 4 Domestic Hot Water 5 Sequencer Control 6 CH Frost Protection 7 DHW Frost Protection 8 Boiler On/Off Switch 9 Warm Weather Shutdown	Reason or cause of boiler demand is displayed with conditions that can prevent a boiler start.
ε 03	Fan Speed Demanded (RPM x 100)	Control output to blower.
ε 04	Fan Speed Feedback (RPM x 100)	Should remain close to Fan Speed Demanded. Large differences may mean there is a problem with blower.
ε 05	3-way Valve Status (0) DHW, (1) CH	3-way valve and pump status indicate controller 120 VAC output status.
ε 06	System Pump On/Off Status	
ε 07	Boiler Pump On/Off Status	
ε 08	Auxiliary Pump On/Off Status	
ε 09	Flame Signal	Flame signal strength displayed in internal calibrated units.
ε 10	Safety Software Revision	Safety software loaded on control.
ε 11	Application Software Revision	Application software loaded on control.
ε 12	Parameter Revision	Indicates factory default parameter setting loaded onto the control.
ε 13	Boiler Size Status: (1) 136 combi (2) 200 combi (3) 080 heat only (4) 120 heat only (5) 150 heat only (6) 180 heat only (7) 136 combi (B) (8) 120 heat only (B)	Read from safety software boiler type status. Must be confirmed after a control board replacement.

19 Troubleshooting *(continued)*

D. Troubleshooting with Active Fault Code.

Control uses following codes to describe abnormal operation:

Table 19-4: Lockout/Hold/Warning Symbol Description

Code	Type	Boiler Status	Description
E	Lockout	Shutdown	When a lockout occurs, boiler will shut down and event is stored in history, b , menu. Once condition that caused lockout is corrected, boiler remains shut down until a reset has been performed by pressing  reset button.
H	Hold	Shutdown	When a hold occurs, boiler will shut down. Event is stored in history, b , menu. Boiler will automatically restart once condition that caused hold is corrected.
	Warning	Free to operate	When a warning occurs, an abnormal condition has affected boiler operation and event is stored in history, b , menu. Boiler continues to operate.

Table 19-5: Active Fault Code and Corrective Actions

Detailed Fault Code found on "b" and "c" menus in brackets, e.g. [*1.0*].

Code/Name	Possible Cause	Corrective Action
H01 Anti-Short Cycle	[<i>1.0</i>] While thermostat demand present, boiler has cycled off too quickly due to temperature and restart is delayed.	Boiler will restart automatically after the minimum off time (Anti-Short Cycle Time, default 3 min.).
	[<i>1.1</i>] Urgent calibration demand present, waiting for supply temperature to decrease.	Boiler will start after supply temperature drops below 95°F (35°C). Low supply temperature helps to ensure a successful calibration. No action is necessary.
H02 Safety Limit Open	External limit is open.	<ul style="list-style-type: none"> • If not using an external limit, check jumper is installed according to wiring diagram. • If using an external water temperature limit see H04/E04 for corrective action. • Verify external limit setting. • Check external limit wiring to boiler, correct if necessary.
	LWCO, low water condition.	<ul style="list-style-type: none"> • If not using a LWCO, check jumper is installed according to wiring diagram. • Check LWCO indicators. If yellow light "On": <ul style="list-style-type: none"> -Verify that system is full of water and all air has been properly purged. Cycle boiler power to initiate pump air elimination function. -Check automatic air vent is unobstructed and properly functioning, (blocked air vent can result in low water condition). If yellow and green light "Off", check LWCO wiring harness.
	Thermal fuse is open.	Check thermal fuse for continuity. If "open", consult manufacturer.

19 Troubleshooting *(continued)*

Table 19-5: Active Fault Code and Corrective Actions (continued)

Detailed Fault Code found on "b" and "c" menus in brackets, e.g. [1.0].

Code/ Name	Possible Cause	Corrective Action
H04 E04 Supply High Limit	Air in system.	Verify system is full of water and the air has been properly purged. Cycle boiler power to initiate pump air elimination function. Air is removed from boiler loop when there are no "air noises" in the heat exchanger.
	System pump, thermostat, zone valve or panel problem.	<ul style="list-style-type: none"> • Check system pump operation, replace if necessary. • Ensure each zone demand produces expected pump, zone valve, and boiler response.
	Piping problem.	Verify boiler is piped properly to heating system. See recommended piping diagram. Correct piping to meet requirements.
	Boiler pump problem.	<ul style="list-style-type: none"> • Verify boiler pump is running and set to speed 3 (Figure 15-2). • Check T5.0 A fuse (Figures 20-1 and 20-2), replace if necessary. • Replace boiler pump if necessary.
	Three way valve not functioning properly.	Valve is powered to move to DHW and CH positions. Stem is down in DHW position (standby position) and up in CH position. If stuck in between disassemble valve and clear any debris. Confirm expected operation with appropriate demand.
	Heating zone too small for installed boiler.	Test individual zones and ensure proper zone sizes.
	Header sensor not sensing temperature. (Modulation sensor set to header sensor or multiple boilers installed)	<ul style="list-style-type: none"> • Check header sensor installation; <ul style="list-style-type: none"> - Surface mount - use heat conductive grease and insulate. - Thermowell - ensure inserted fully. • Check header sensor temperature is close to and tracks with supply sensor. If difference greater than 5°F (3°C), move header sensor to location to better sense supply water temperature.
H05 E05 Low Water Flow	Air in system.	Verify system is full of water and the air has been properly purged. Cycle boiler power to initiate pump air elimination function. Air is removed from boiler loop when there are no "air noises" in the heat exchanger.
	Piping problem.	Verify boiler is piped properly to heating system. See recommended piping diagram. Correct piping to meet requirements.
	Boiler pump problem.	<ul style="list-style-type: none"> • Verify boiler pump is running and set to speed 3 (Figure 15-2). • Check T5.0 A fuse (Figures 20-1 and 20-2), replace if necessary. • Replace pump if necessary.
	Boiler flow switch defective.	<ul style="list-style-type: none"> • Check switch wiring to boiler. • Check boiler flow switch for proper operation. <ul style="list-style-type: none"> - Open with no water flow - Closed with water flow
	Flow restriction or clogged strainer.	Verify there are no restrictions and clean strainer if present.
	Pump rotor seized (initial start up)	Remove silver cap on boiler pump head and spin rotor counter-clockwise to free pump rotor.

19 Troubleshooting *(continued)*

Table 19-5: Active Fault Code and Corrective Actions (continued)

Detailed Fault Code found on "b" and "c" menus in brackets, e.g. [1.0].



Code/Name	Possible Cause	Corrective Action
H06 E06 Flue High Limit	Heat exchanger dirty.	Check heat exchanger for excessive fouling. Clean if necessary. Heat exchanger cleaning kit available. See accessories section.
H07 E07 Return Temp Higher than Supply	Flow through boiler reversed.	<ul style="list-style-type: none"> • Verify correct piping and pump orientation. • Check pump orientation.
	Supply or return sensor not installed properly or sensor defective.	<ul style="list-style-type: none"> • Check supply and return sensors are installed correctly. • Replace if necessary.
H08 Return Sensor Fault	Shorted or miswired return temperature sensor.	<ul style="list-style-type: none"> • Check return sensor wiring, correct wiring if necessary. • Check return sensor, refer to sensor temperature vs. resistance (Table 19-7). Replace sensor if necessary.
H09 E09 Supply Sensor Fault	[9.0 or 9.1] Shorted, opened or miswired supply temperature sensor.	<ul style="list-style-type: none"> • Check supply sensor wiring, correct wiring if necessary. • Check supply sensor, refer to sensor temperature vs. resistance (Table 19-7). Replace sensor if necessary.
	[9.2] Temperature difference between dual elements too high.	Measure resistance of each thermistor and compare, refer to sensor temperature vs. resistance (Table 19-7). Replace sensor if necessary.
H10 DHW Sensor Fault	Shorted, opened or miswired DHW temperature sensor.	<ul style="list-style-type: none"> • Check DHW sensor wiring, correct wiring if necessary. • Check DHW sensor, refer to sensor temperature vs. resistance (Table 19-7). Replace sensor if necessary.
H11 E11 Flue Sensor Fault	Shorted, opened or miswired flue temperature sensor.	<ul style="list-style-type: none"> • Check flue sensor wiring, correct wiring if necessary. • Check flue sensor, refer to sensor temperature vs. resistance (Table 19-7). Replace sensor if necessary.
H12 Outdoor Air Sensor Fault	Shorted, opened or miswired outdoor air temperature sensor.	<ul style="list-style-type: none"> • Check outdoor air sensor wiring, correct wiring if necessary. • Check outdoor sensor, refer to sensor temperature vs. resistance (Table 19-7). Replace sensor if necessary.
H13 Header Or Recirculation on Sensor Fault	Shorted, opened or miswired header or recirculation temperature sensor.	<ul style="list-style-type: none"> • Check header or recirculation sensor wiring, correct wiring if necessary. • Check header sensor, refer to sensor temperature vs. resistance (Table 19-7). Replace sensor if necessary.
	Recirculation (Comfort) Mode selected and recirculation temperature sensor not installed.	Disable Recirculation (Comfort) Mode or install a recirculation temperature sensor.
H14 0-10 Vdc / 4-20 mAdc Input Fault	[14.0 or 14.1]* Shorted or miswired 0-10 Vdc / 4-20 mAdc input.	<ul style="list-style-type: none"> • Check 0-10 Vdc/4-20 mAdc input source wiring to boiler, correct wiring if necessary (for example, swap two wires). • Verify proper operation of external device.
	[14.2]* Analog input parameter setup incorrect.	Verify parameter settings on boiler.

***Feature only available with PAT-Connect Bluetooth Adaptor and App.**

19 Troubleshooting *(continued)*

Table 19-5: Active Fault Code and Corrective Actions (continued)

Detailed Fault Code found on "b" and "c" menus in brackets, e.g. [1.0].

Code/Name	Possible Cause	Corrective Action
E 15 Air Proving Switch (APS) Defective (failed to open)	Defective air proving switch, failed to open.	<ul style="list-style-type: none"> Remove jumper from air proving switch. Check continuity on switch. Should be open with no air flow. Replace switch if necessary.
	Blower is running before start sequence, communication loss between control and blower.	<ul style="list-style-type: none"> Check wiring between control and blower, correct wiring if necessary. Replace blower if necessary. If problem persists, replace control.
H 16 E 16 Low Combustion Air Flow	Air flow is blocked.	<ul style="list-style-type: none"> Check vent and air inlet for blockage. Remove blockage. Check heat exchanger for excessive fouling. Clean if necessary. Check integrity of burner. Replace burner (including burner door) if necessary.
	APS (air proving switch) not connected to harness.	Connect harness to APS. Note different size spade connectors.
	Tube to APS is not connected or obstructed.	<ul style="list-style-type: none"> Check tube is connected and unobstructed. Replace tubing if necessary.
	Defective APS.	<ul style="list-style-type: none"> Check switch for proper operation <ul style="list-style-type: none"> -Switch is open when blower off. -Switch is closed when blower is on (negative pressure) Replace APS if necessary.
	Defective blower.	<ul style="list-style-type: none"> Check blower wiring connections (120 VAC and control connectors), correct wiring if necessary. Replace blower if necessary.
H 17 E 17 Invalid Safety Parameters	[17.0] Control in program mode.	Cycle power.
	[17.4] Boiler Type and BCC mismatch.	 WARNING
		Asphyxiation Hazard. Boiler type is factory set and must match boiler model. Boiler type BCC determines minimum and maximum blower speeds. Incorrect BCC could cause hazardous burner conditions and improper operation resulting in severe personal injury, death or substantial property damage. To verify boiler type BCC is correct, a qualified technician should do the following: <ul style="list-style-type: none"> Check boiler model and insert correct Boiler Type BCC. Check wiring to Model Key located inside control enclosure.
	[17.5] Invalid fuel or altitude selection or power is cycled too soon after a fuel selection.	Select desired fuel and altitude. If fuel selection [17.5] on local display and power is cycled too fast, select original fuel to clear alarm before reselecting desired fuel.
	[17.7] Parameter transfer from a new BCC is required or in progress.	Shows as H 17 on screen. When process complete, screen will return to normal. No action is necessary.
	[17.8] BCC is missing.	Remove and reconnect BCC and cycle power. Press  reset button after power is re-established. If problem persists, replace control.
	[17.1, 17.2, 17.3, 17.5, 17.6] Control is defective.	Cycle power to control, Press  reset button after power is re-established. If problem persists replace control.

19 Troubleshooting *(continued)*

Table 19-5: Active Fault Code and Corrective Actions (continued)

Detailed Fault Code found on "b" and "c" menus in brackets, e.g. [1.0].

Code/Name	Possible Cause	Corrective Action
H 18 E 18 Invalid Application Parameters	[18.0] Application parameters are not valid.	Normal condition following a parameter download, set Factory Defaults, parameter H 10 . (Table 16-11, Menu H , Quick Menu)
	[18.1] Parameter Model Mismatch.	Repeat reset to factory default using parameter H 10 . If problem persists, replace control.
	[18.2]* CH Setpoint and Modulation source both selected.	Only CH Setpoint or Modulation source may be selected. Select only a single feature. Check Central Heat Modulation Rate Source and Central Heat Setpoint Source.
	[18.3]* Invalid header sensor configuration.	Recirculation vs. Header Selection parameter must be set to "Header" when selecting CH Modulation Sensor parameter selection to "Header".
	[18.4]* Invalid Stepped modulation parameters (Start Offset Recycle Limit)<5°F (3°C).	Consult manufacturer.
	[18.5]* Invalid Setpoint interpolation parameters.	Check CH 20 mA Water Temperature is greater than CH 4 mA Water Temperature.
	[18.6]* Invalid Recirc (Comfort) Mode configuration.	Recirc (Comfort) Mode selected and Header/Recirculation vs. Header Selection parameter is not set to "Recirculation" or Auxiliary thermostat input selection not set to "Recirculation".
	[18.7] Factory defaults not turned on.	Ensure BCC is installed and select H 10 factory Default "On" (Table 16-11).
	[18.8] Pump mismatch.	P02 Boiler Pump Output Selection parameter set to "Pump Not Used" or P02 Boiler Pump Output Selection parameter set to "Boiler Pump CH Only Off for DHW" and P03 Auxiliary Pump Output Selection parameter is not set to "DHW Pump Boiler Piped IWH". Refer to Table 16-15.
E 19 Flame Signal Fault During Run	No gas, insufficient gas supply pressure.	<ul style="list-style-type: none"> • Verify no air in gas line. • Check gas valve inlet pressure while boiler off and during operation.
H20 E20 Flame Signal Fault During Calibration	[20.0] No gas, insufficient gas supply pressure.	<ul style="list-style-type: none"> • Verify no air in gas line. • Check gas valve inlet pressure while boiler off and during operation.
	[20.1] Flame signal too low during calibration.	<ul style="list-style-type: none"> • Check air inlet for obstructions. Remove if necessary. • Check vent and air inlet for evidence of flue gas recirculation. Change venting to eliminate flue gas recirculation.
	[20.2] Calibration too different from previous result and combustion condition changed too much since last calibration.	Check air inlet does not contain dust particles or other combustibles. If possible, relocate air inlet to different location.
	[20.3] Calibration too different from previous result and combustion condition changed too much since last calibration.	<ul style="list-style-type: none"> • Check vent and air inlet for evidence of flue gas recirculation. Change venting to eliminate flue gas recirculation. • Use PAT Connect Bluetooth Adapter and App to perform "Calibration Recovery" located under Adjust/Modulation.
	[20.4] Defective control.	Replace control.

*Feature available with PAT Connect Bluetooth Adaptor and App.

19 Troubleshooting *(continued)*

Table 19-5: Active Fault Code and Corrective Actions (continued)



Detailed Fault Code found on "b" and "c" menus in brackets, e.g. [1.0].

Code/ Name	Possible Cause	Corrective Action
H21 E21 Fuel Gas Fault	[2 1.0], [2 1.2] No gas, insufficient gas supply pressure.	<ul style="list-style-type: none"> • Verify no air in gas line. • Check gas valve inlet pressure while boiler off and during operation.
	[2 1.0], [2 1.2] Flame signal unstable at specific firing rate.	Manually modulate boiler from max load to min load in 10% increments. Monitor flame signal. If flame signal fluctuates greater than 10 points almost instantly, reduce gas pressure and perform test again. Consult manufacturer if problem persists.
	[2 1.1] Defective gas valve.	<ul style="list-style-type: none"> • Check gas valve wiring, correct if necessary. • Check gas valve inlet pressure during operation. • If problem persists, replace gas valve. • If problem persists, replace control.
	[2 1.3] Gas valve wiring problem.	
H22 E22 No Flame After Ignition	Ignition cable not plugged in.	Connect ignition cable.
	Break in ignition cable.	Check ignition cable continuity.
	Fuel Gas Selection, parameter R05 or gas valve setting is incorrect.	Check Fuel Gas Selection, parameter R05, and gas valve setting (Figure 15-3). Both selections must be set to the same fuel type.
	No gas, insufficient gas supply pressure.	<ul style="list-style-type: none"> • Verify no air in gas line. • Check gas valve inlet pressure while boiler off and during operation.
	Lean ignition mixture.	After verifying no air in gas piping and gas supply pressure, gradually increase (1% at a time) parameter F07 until successful ignition.
	Dirty or damaged ignitor/flame sensor.	Check ignitor/flame sensor gap and distance to burner. See Figure 18-2 and Table 18-3 for distance specifications. Replace ignitor/flame sensor if necessary.
H23 E23 Flame Out Of Sequence	[23.0] Blocked condensate trap.	Check trap and clean if necessary.
	[23.1] Defective gas valve.	Replace gas valve.
	[23.2], [23.3] Defective control.	Replace control.

19 Troubleshooting *(continued)*

Table 19-5: Active Fault Code and Corrective Actions (continued)

Detailed Fault Code found on "b" and "c" menus in brackets, e.g. [1.0].

Code/ Name	Possible Cause	Corrective Action
H24 E24 Flame Loss During Run	No gas, insufficient gas supply pressure.	<ul style="list-style-type: none"> • Verify no air in gas line. • Check gas valve inlet pressure while boiler off and during operation.
	The boiler has not started due to high winds.	The control automatically raised the minimum capacity value to help prevent high wind from preventing ignition again. Minimum capacity is returned to normal after one hour.
	Air flow is blocked.	<ul style="list-style-type: none"> • Check vent and air inlet for blockage. Remove blockage. • Check heat exchanger for excessive fouling. Clean if necessary. • Check integrity of burner. Replace burner (including burner door) if necessary.
	Dirty or damaged ignitor/ flame sensor.	Check ignitor/flame sensor gap and distance to burner. See Figure 18-2 and Table 18-3 for distance specifications. Replace ignitor/Flame sensor if necessary.
	Defective burner.	Check integrity of burner. Replace burner (including burner door) if necessary.
	Blocked condensate trap.	Check the condensate trap and clean if necessary.
	Fuel Gas Selection, (parameter <i>F05</i>), Altitude Selection (parameter <i>F07</i>) or gas valve setting is incorrect.	Check Fuel Gas Selection, parameter <i>F05</i> , and gas valve setting (Figure 15-3). Both selections must be set to same fuel type. Also, check Altitude Selection (parameter <i>F07</i>) is correct for installation elevation.
	Turndown too high.	Reduce turndown by increasing <i>F05</i> Minimum Capacity.
H25 E25 Hardware Fault	Defective control.	Replace control.
H26 E26 Calibration Fault	[25.0] Too long running at calibration without going to minimum capacity.	Cycle power to initiate calibration.
	[25.1], [25.2], [25.3] Calibration has not been possible.	<ul style="list-style-type: none"> • Resolve issue preventing boiler from running for approximately 1.5 minutes during calibration demand [<i>5LR</i> =5]. • Cycle power to initiate a calibration.
H27 120 VAC Supply Fault	120 VAC supply voltage less than 73 VAC.	Check 120 VAC supply, correct issue.
H28 24 VAC Supply Fault	Control 24 VAC wrong frequency.	Check 120 VAC supply, correct issue.
	Defective control.	Replace control.
E29 Excessive Reset Selection	Control  reset button has been selected too often.	To clear, cycle power to control and press  reset button above local display.

19 Troubleshooting *(continued)*

Table 19-5: Active Fault Code and Corrective Actions (continued)

Detailed Fault Code found on "b" and "c" menus in brackets, e.g. [1.0].

Code/ Name	Possible Cause	Corrective Action
H30 Sequencer Fault	[30.0] Duplicate Slave Boiler Addresses	Ensure each peer-to-peer boiler has a unique slave address between 1 and 8.
	[30.1] Sequencer slave has lost communication with Sequencer Master, master header sensor failure.	<ul style="list-style-type: none"> • Check boiler to boiler connection wiring. • Check master is powered and configured. • Check header sensor wiring or configuration.
	[30.2] Multiple sequencer masters detected.	Check each boiler Lead Lag Master Enable, parameter L01, setup. Only one boiler may be set as Sequencer Master Enabled.
	[30.3]* Modbus setpoint signal.	Check wiring to Energy Management System.
	[30.4] Modbus modulation signal.	
H31 Variable Speed Pump Fault	Variable Speed Pump feedback fault.	Check wiring to Variable Speed Pump. Defective pump electronics or control, replace pump or control if necessary.
H32 Zone Panel Fault	[32.0 to 32.3] Zone Panel Communication Lost.	<ul style="list-style-type: none"> • Check wiring between panels and boiler. • Check Zone Panel Dip Switch Settings: <ul style="list-style-type: none"> - Set Master/Slave Dip Switch on zone panel to "master" all others set to "slave". - Set ZC Dip Switch Zone Panel 1 "ZC1" to "ON". Zone Panel 2 "ZC2" to "ON", etc. • Cycle Power.
	[32.4] Zone Panel Electronics Failure.	<ul style="list-style-type: none"> • Check wiring Zone Panel main and daughter board. • Power up one panel at a time to isolate problem. • Replace panel if problem persists.
	[32.5] Duplicate Zone Panel.	<ul style="list-style-type: none"> • Check each ZC Dip Switch set to a unique setting: ZC1, ZC2, ZC3, ZC4. • Check when multiple switches are set to "ON" the zone is reported as panel 1.

*Feature available with PAT-Connect Bluetooth Adaptor and App.

19 Troubleshooting *(continued)*

Table 19-6: Detailed Fault Code (found on "c" and "b" menus)

Code	Detailed Code	Type	Condition
H01	H01.0	Warning	Anti-short cycle boiler start delay, while thermostat demand present, boiler has cycled off and restart is delayed.
	H01.1	Warning	Urgent calibration cooling delay. Boiler start delay, urgent calibration is present, waiting for supply temperature to decrease.
H02	H02.0	Hold	A safety limit is open and preventing boiler from starting.
H04 E04	H04.0	Hold	Supply Temperature is higher than 200°F (93°C) or (when used). Preferred Outlet/Flow High Limit parameter setting (minus 10°).*
	E04.1	Lockout	Supply Temperature is higher than 210°F (99°C) or (when used). Preferred Outlet/Flow High Limit parameter setting.*
H05 E05	H05.0	Hold	Temperature rise between supply and return greater than 63°F (17°C).
	H05.1	Hold	Boiler flow switch does not detect water flow. Switch contact is "open" when it should be "closed".
	E05.2	Lockout	Boiler flow switch does not detect water flow. Switch contact is "open" when it should be "closed" after 5 retries.
	E05.3	Lockout	Temperature rise between supply and return is greater than 63°F (17°C).
	E05.4	Lockout	Boiler water flow switch contact is "closed" when it should be "open".
H06 E06	H06.0	Hold	Flue sensor detected temperatures in excess of 194°F (90°C) or when used. Preferred Stack/Flue Limit parameter (minus 10°).*
	E06.1	Lockout	Flue sensor detected temperatures in excess of 204°F (96°C) or when used. Preferred Stack/Flue Limit parameter.*
H07 E07	H07.1	Hold	Return temperature higher than supply temperature.
	E07.0	Lockout	Return temperature higher than supply temperature after 10 retries.
H08	H08.0	Hold	Shorted, opened or miswired return temperature sensor.
H09 E09	H09.0	Hold	Shorted, opened or miswired supply temperature sensor.
	E09.1	Lockout	Shorted, opened or miswired supply temperature sensor longer than 10 seconds.
	E09.2	Lockout	Temperature difference between two thermistors too high.
H10	H10.0	Warning	Shorted, opened or miswired DHW temperature sensor.
H11 E11	H11.0	Hold	Shorted, opened or miswired Flue temperature sensor.
	E11.1	Lockout	Shorted, opened or miswired Flue temperature sensor longer than 10 seconds.
H12	H12.0	Warning	Shorted, opened or miswired outdoor air temperature sensor.
H13	H13.0	Hold	Shorted, opened or miswired Header temperature sensor.
H14	H14.0	Hold	0-10Vdc Input is out of range.
	H14.1	Hold	4-20mAadc Input is out of range.
	H14.2	Hold	Analog Input parameter setup incorrect.
E15	E15.0	Lockout	The air proving switch detects airflow while fan is not running. Switch contact is "closed" when it should be "open".
H16 E16	E16.0	Lockout	Air proving switch does not detect air flow for more than 51 seconds.
	E16.1	Lockout	Fan standstill not reached.
	H16.2	Hold	Fan speed is not proven during running mode.
	E16.3	Lockout	Fan speed is not proven during prepurge or post purge.

19 Troubleshooting *(continued)*

Table 19-6: Detailed Fault Code (found on "c" and "b" menus, continued)

Code	Detailed Code	Type	Condition
H 17 E 17	H 17.0	Hold	Internal safety core in program mode.
	H 17.1	Hold	Internal safety core error.
	E 17.2	Lockout	Internal safety core error.
	E 17.3	Lockout	Internal safety core error.
	H 17.4	Hold	Model Key and BCC mismatch.
	E 17.5	Lockout	Application parameter does not match safety core parameter.
	H 17.6	Hold	Application fuel selection does not match safety core parameter.
	H 17.7	Hold	BCC updating safety parameters.
	E 17.8	Lockout	BCC is missing, has incompatible software revision or is damaged.
H 18 E 18	E 18.0	Lockout	Application parameters are not valid, normal condition following a new parameter download.
	H 18.1	Hold	Actual boiler model doesn't match with control detected model during factory default reset.
	H 18.2	Hold	CH setpoint and modulation source both selected.
	H 18.3	Warning	Invalid header sensor configuration.
	H 18.4	Hold	Invalid stepped modulation parameters (Start Offset-Recycle Limit)<5°F.
	H 18.5	Warning	Invalid energy management CH setpoint 0Vdc/4mA and 10Vdc/20mA settings.
	H 18.6	Hold	Invalid recirculation vs. header selection parameter setting.
	E 18.7	Lockout	Selected boiler model default parameters not available on control.
	H 18.8	Hold	P02 Boiler Pump Output parameter set to "Pump Not Used" or P02 Boiler Pump Output Select parameter set to "Boiler Pump CH Off for DHW" and P03 Auxiliary Pump Outlet Selection parameter is not set to "DHW Pump Boiler Piped IWH". Refer to Table 16-15.
E 19	E 19.0	Lockout	Flame signal deviation from setpoint too high.
H20 E20	H20.0	Warning	Flame signal deviation from setpoint too high.
	E20.1	Lockout	Flame signal too low during calibration.
	E20.2	Lockout	Flame signal too high during calibration.
	E20.3	Lockout	Calibration too different from previous result and combustion condition changed too much since last calibration.
	E20.4	Lockout	Defective control.
H21 E21	H21.0	Hold	Flame signal deviation from setpoint too high.
	H21.1	Hold	Defective gas valve.
	E21.2	Lockout	Flame signal deviation from setpoint too high.
	E21.3	Lockout	Gas valve wiring problem.
H22 E22	H22.0	Hold	Flame signal too low at burner start. H22.0 shown after first four unsuccessful attempts. One hour hold after third unsuccessful attempt.
	E22.1	Lockout	Flame signal too low at burner start. E22.1 shown after fifth unsuccessful attempt.

19 Troubleshooting *(continued)*

Table 19-6: Detailed Fault Code (found on "c" and "b" menus, continued)

Code	Detailed Code	Type	Condition
H23 E23	E23.0	Lockout	Flame detected before burner start.
	E23.1	Lockout	Flame detected for 15s after gas valve closed.
	H23.2	Hold	Defective Control: flame amplifier.
	E23.3	Lockout	Defective Control: flame amplifier. Happens after second H24.2
H24 E24	H24.0	Warning	Flame signal loss in operation. Minimum firing rate raised for 1 hour.
	H24.1	Hold	Flame signal loss in stabilization phase.
	H24.2	Hold	Flame signal loss in safety time.
	E24.3	Lockout	Flame signal loss in safety time.
H25 E25	H25.0	Hold	Defective control: internal safety core error.
	E25.2	Lockout	Defective control: internal application core error.
	E25.3	Lockout	Defective control: internal safety core error.
	E25.4	Lockout	Defective control: internal safety core error.
	E25.5	Lockout	Defective control: internal safety core error.
	E25.6	Lockout	Defective control: unknown internal safety core error.
H26 E26	H26.0	Hold	Calibration fault: stable conditions to perform gas valve offset adaptation not reached.
	H26.1	Hold	Calibration fault: stable conditions to perform calibration not reached.
	E26.2	Lockout	Calibration fault: missing calibration. Calibration counter reached zero.
	H26.3	Warning	Calibration fault: emergency stop during calibration due to high outlet/DHW temp or blocking/lockout error.
H27	H27.0	Hold	120 VAC supply voltage less than 73 VAC.
H28	H28.0	Hold	Control 24 VAC wrong frequency or high electrical noise.
E29	E29.0	Lockout	Excessive  reset button selection.
H30	H30.0	Hold	Duplicate slave boiler addresses.
	H30.1	Warning	Sequencer slave has lost communication with sequencer master, or master header sensor failure.
	H30.2	Hold	Multiple sequencer masters detected.
	H30.3	Warning	Communication fault: no valid Modbus setpoint signal.
	H30.4	Warning	Communication fault: no valid Modbus setpoint signal.
H31	H31.0	Hold	Variable Speed Pump Fault and pump feedback is used to prove boiler water flow.
	H31.1	Warning	Variable Speed Pump Fault and flow switch is used to prove boiler water flow.

19 Troubleshooting *(continued)*

Table 19-6: Detailed Fault Code (found on "c" and "b" menus, continued)

Code	Detailed Code	Type	Condition
H32	H32.0	Warning	Zone Panel 1 Communication Lost.
	H32.1	Warning	Zone Panel 2 Communication Lost.
	H32.2	Warning	Zone Panel 3 Communication Lost.
	H32.3	Warning	Zone Panel 4 Communication Lost.
	H32.4	Warning	Zone Panel Electronics Failure.
	H32.5	Warning	Duplicate Zone Panel.

19 Troubleshooting *(continued)*

Table 19-7: Supply, DHW, Return Header and Flue Temperature Sensor Temperature versus Resistance (10 kOhm)

Temperature		Ohms of Resistance
°F	°C	
32	0	32624
50	10	19897
68	20	12493
77	25	10000
86	30	8056
104	40	5324
122	50	3599
140	60	2483
158	70	1748
176	80	1252
194	90	912
212	100	674
230	110	506
248	120	384

Table 19-8: Outdoor Air Temperature Sensor Temperature versus Resistance (10 kOhm)

Outdoor Temperature		Ohms of Resistance
°F	°C	
-20	-28.9	106926
-10	-23.3	80485
0	-17.8	61246
10	-12.2	47092
20	-6.7	36519
30	-1.1	28558
40	4.4	22537
50	10.0	17926
60	15.6	14356
70	21.1	11578
76	24.4	10210
78	25.6	9795
80	26.7	9398
90	32.2	7672
100	37.8	6301
110	43.3	5203
120	48.9	4317

20 Internal Wiring Diagrams

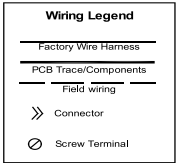
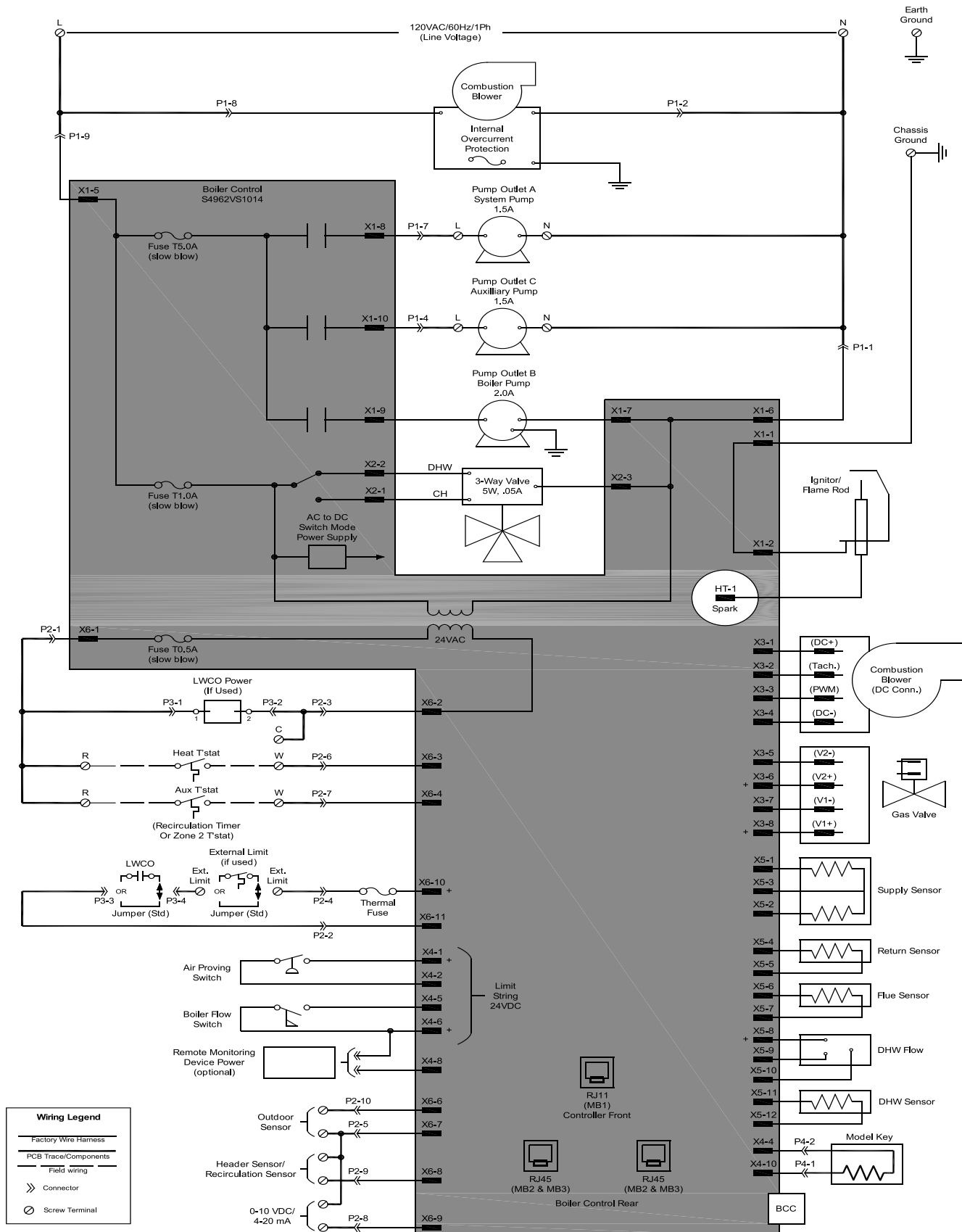
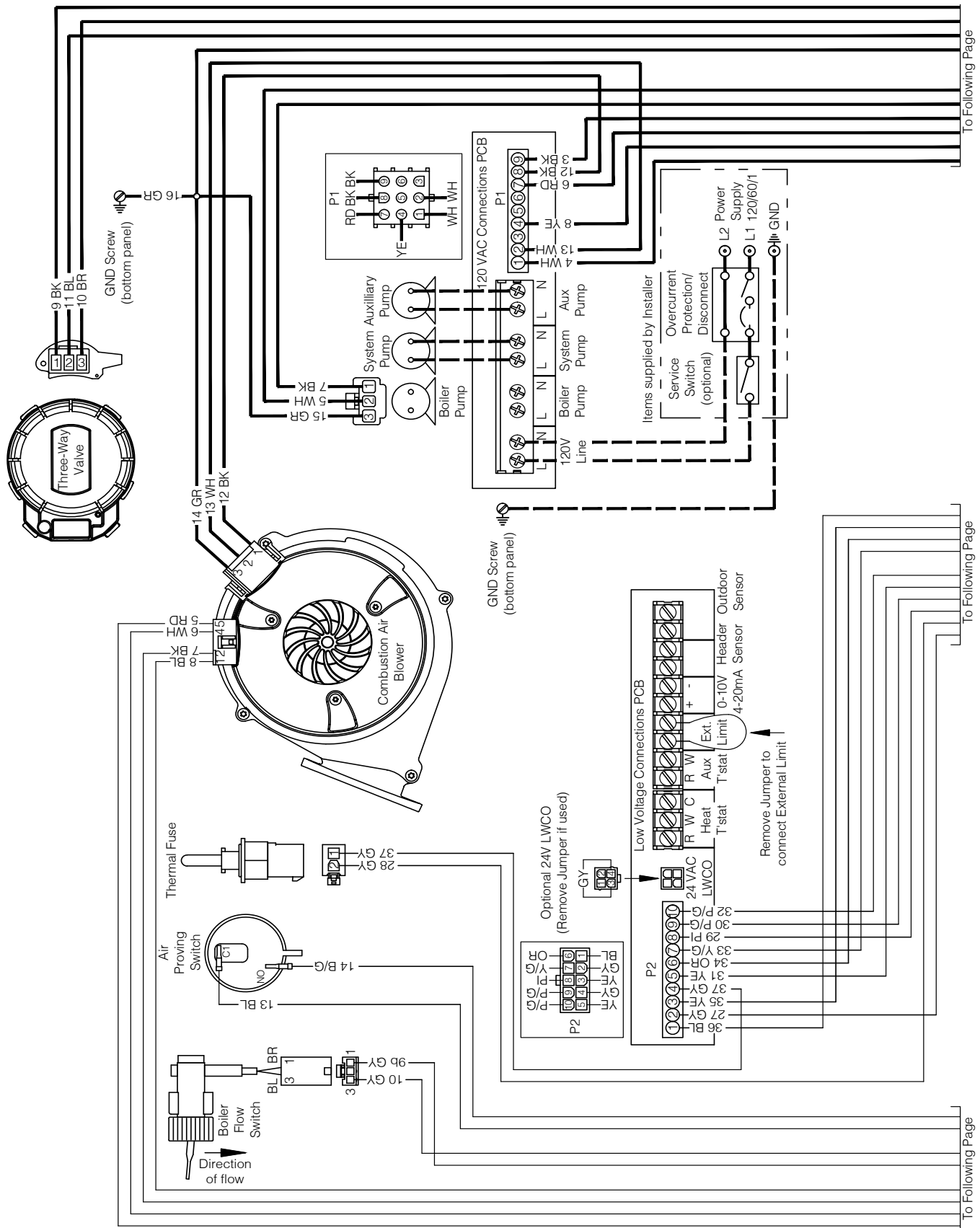

Figure 20-1: Ladder Diagram

20 Internal Wiring Diagrams (continued)



To Following Page

To Following Page

To Following Page

20 Internal Wiring Diagrams *(continued)*

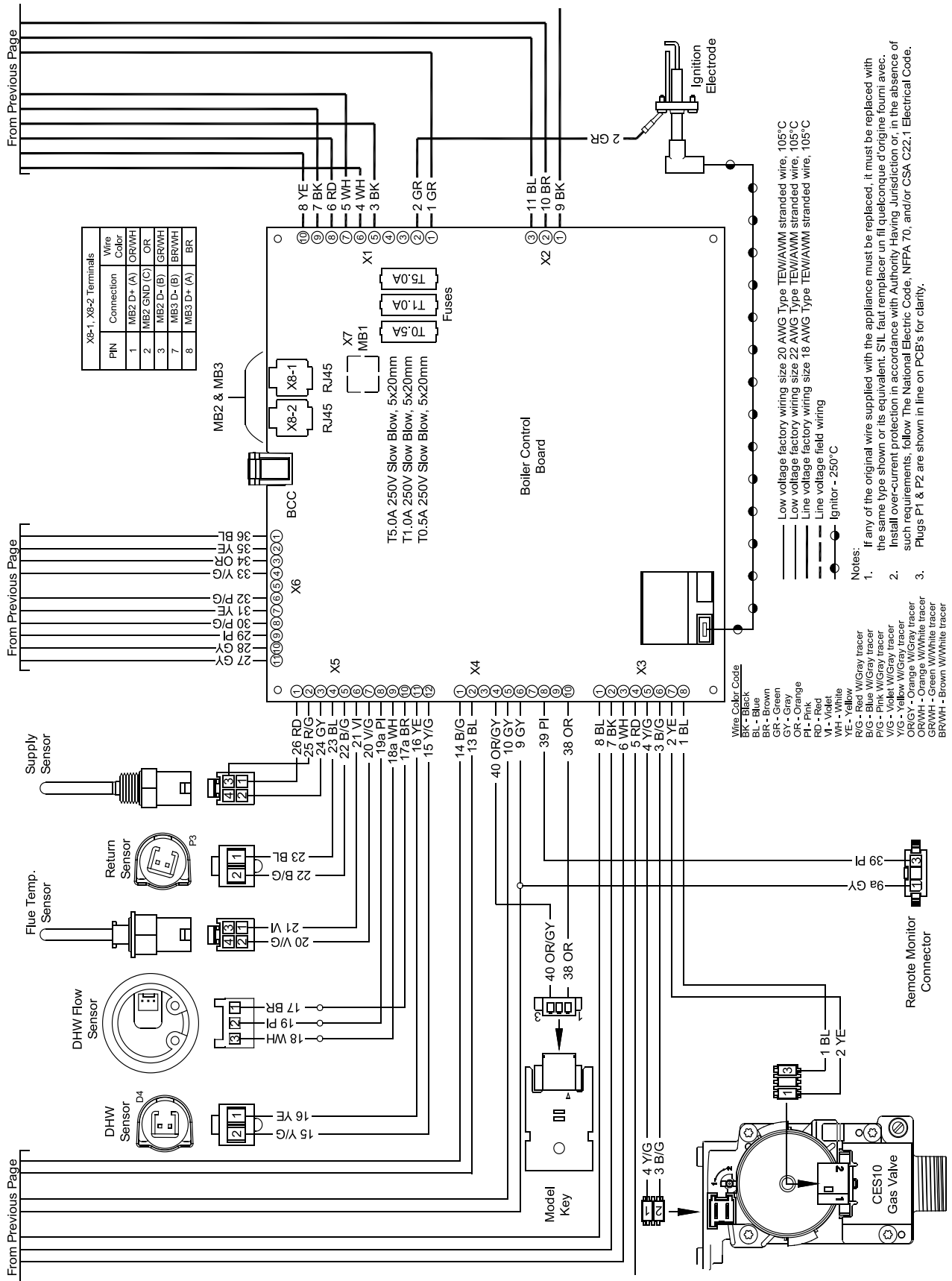
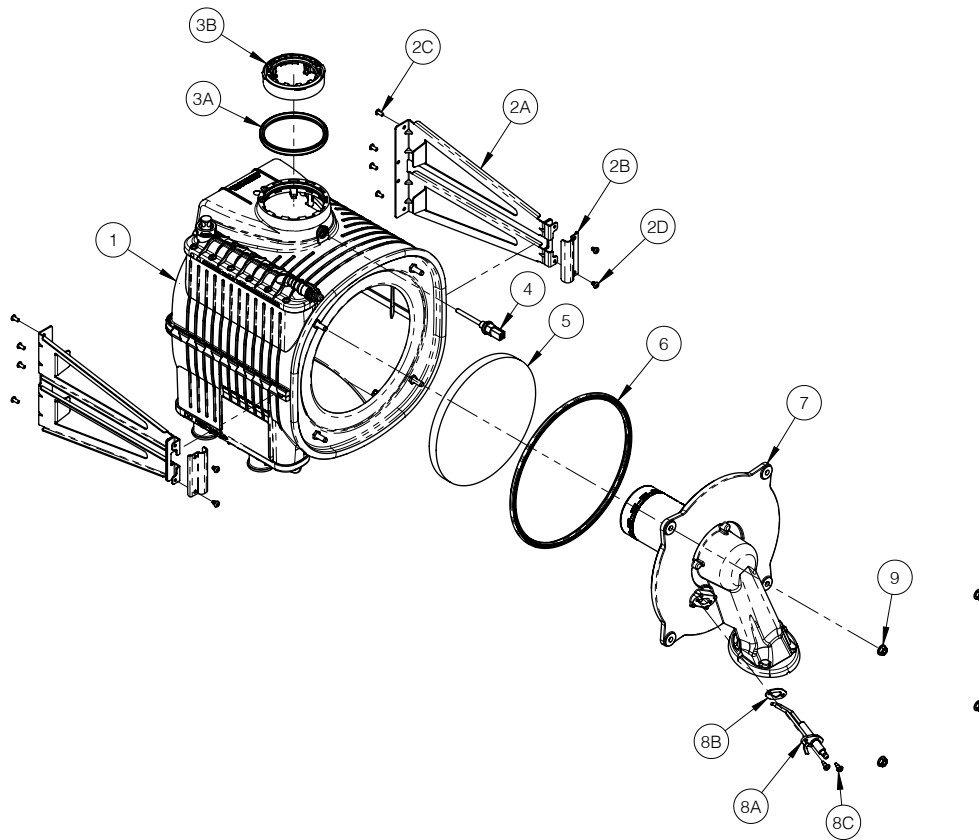

Figure 20-2: Wiring Schematic Diagram

21 Service Parts

All service parts may be obtained through your local Velocity Boiler Works wholesale distributor. Should you require assistance in locating a Velocity Boiler Works distributor in your area, or you have questions regarding the availability of products or service parts, please contact us at (215) 535-8900 or Fax (215) 535-9736 or at www.velocityboilerworks.com



Key No.	Description	Part Number		
		PHTM2136C	PHTM2136CB	PHTM2200C
1	Heat Exchanger	Contact Velocity Boiler Works; Provide boiler serial number		
2A	Fixing Clamp Bracket			
2B	Holding Clamp			
2C	Pop Rivet 5/32 x 3/16 in. (.126-.187 Grip)			
2D	10-32 x 1/2 in. Thread Cutting Screw			
3A	Flue Outlet Gasket	105882-01		
3B	Flue Adapter 3 in. to 2 in.			
4	Flue Temperature Sensor	105883-01		
5	Rear Target Wall Insulation	105651-01		
6	Burner Door Gasket	110880-01		
6, 7	Burner Door Assembly (includes burner ignitor/flame sensor, gasket and hardware)	110575-01	111970-01	111560-01
8A, 8B, 8C	Ignitor/Flame Sensor (includes sensor, gasket and hardware)	111423-01		
8B	Ignitor/Flame Sensor Gasket	106527-01		
9	M6 Serrated Flange Hex Nut	Obtain locally		

21 Service Parts *(continued)*

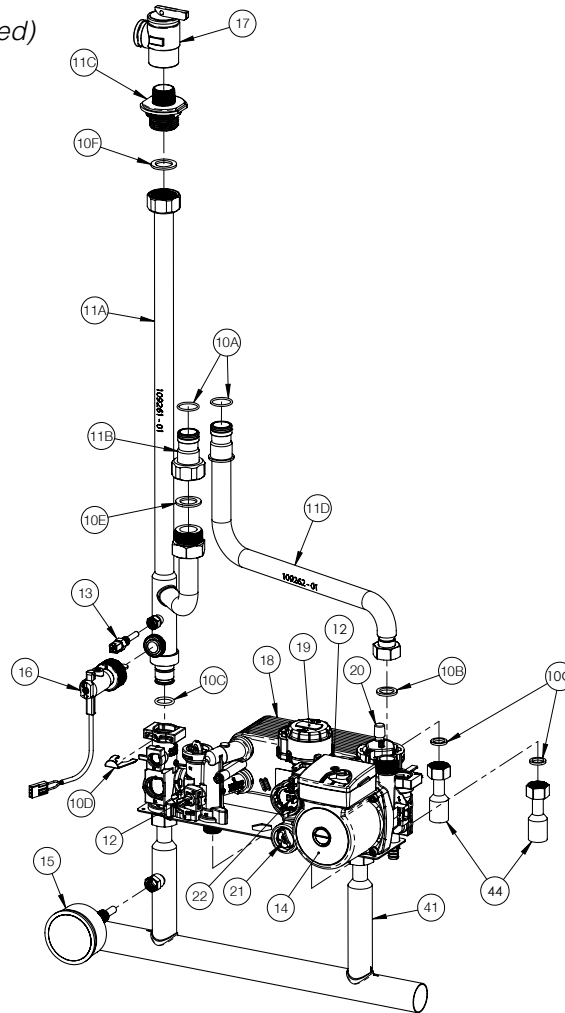

Key No.	Description	Part Number		
		PHTM2136C	PHTM2136CB	PHTM2200C
10A, 10B, 10C, 10D, 10E, 10F, 10G	Water Pipe Gaskets	110577-01		
11A, 11B, 11C, 11D	Water Pipes (w/ gaskets)	110578-01		111563-01
12	DHW	110579-01		
12	Return Temp. Sensor	110579-01		
13	Supply Temp. Sensor	106994-01		
14	Pump	110580-01		
15	T&P Gauge	108215-01		
16	Boiler Flow Switch & O-ring	105892-01		
17	30 psig (207 kPa) Safety Relief Valve	108680-01		
18	Plate Heat Exchanger	110581-01		
19	3 Way Valve	110582-01		
20	Air Vent	110583-01		
21	Flow Restrictor	110584-01		
22	DHW Flow Sensor	110585-01		
41	Low Loss Header	110724-01		
10G, 44	DHW connector (w/ gaskets)	110878-01		
12, 14, 13, 19, 20, 21, 22	DHW Block Assembly	111421-01		

21 Service Parts *(continued)*

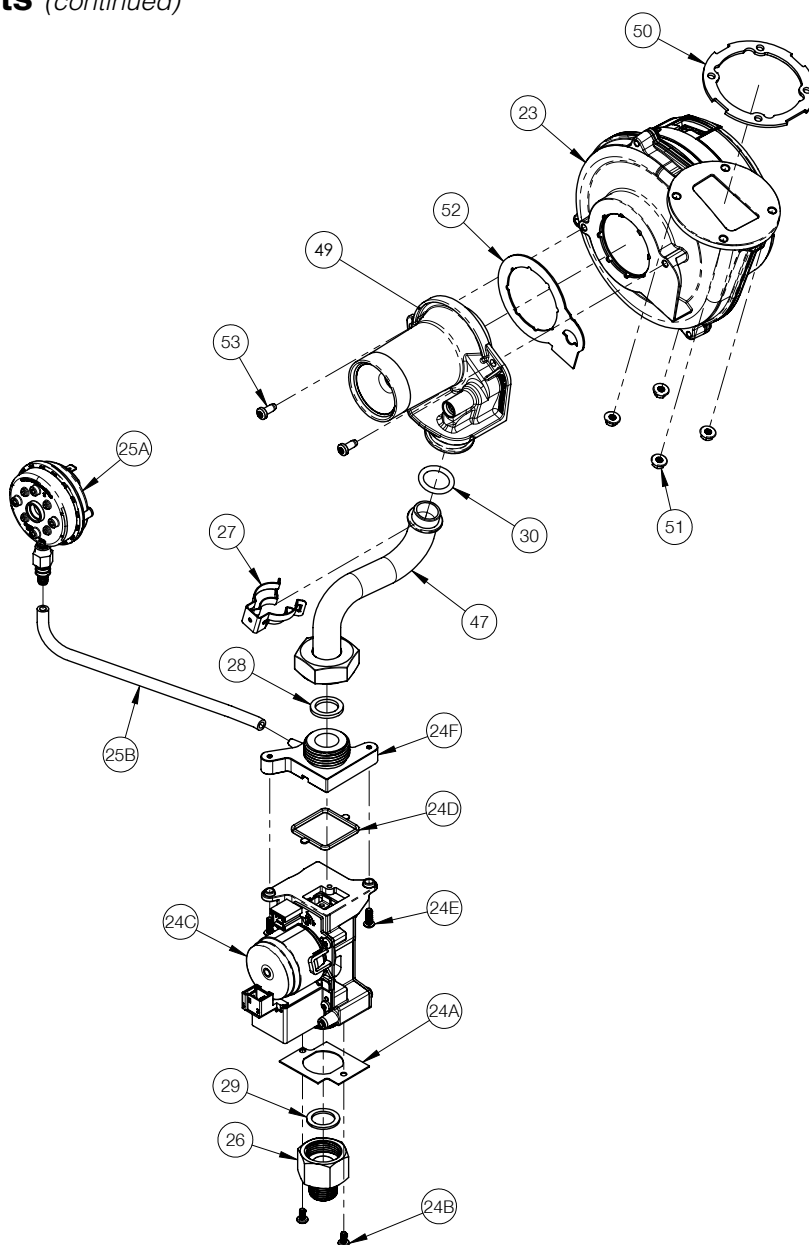

Key No.	Description	Part Number		
		PHTM2136C	PHTM2136CB	PHTM2200C
23, 27, 28, 30, 50, 51, 52, 53	Blower (with gaskets, o-rings, and hardware)	110586-01		111571-01
24A, 24B, 24C, 24D, 24E, 24F, 28, 29	Gas Valve (with gaskets, o-rings, and hardware)	110587-01		111564-01
25A, 25B	Air Proving Switch (tubing- 5/16 in. x 12 in. long.)	107862-01		
26, 27, 28, 29, 30, 47	Gas piping (with gaskets, o-rings, and hardware)	110588-01		
28, 29, 30, 50, 52	Gas pipe gaskets	110879-01		
26, 29	Gas adaptor	111422-01		
27, 28, 29, 30, 49, 50, 51, 52, 53	Venturi	110881-01		

21 Service Parts *(continued)*

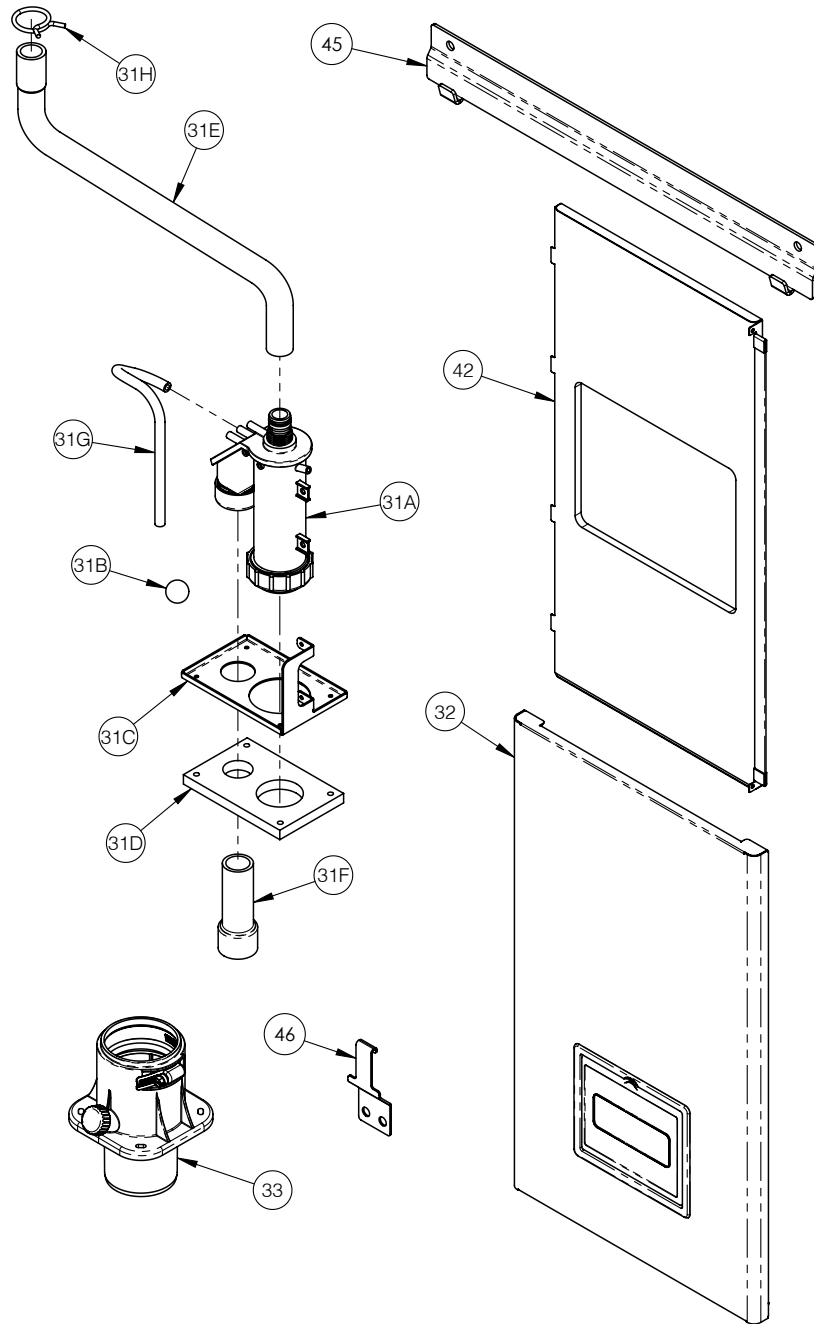

Key No.	Description	Part Number		
		PHTM2136C	PHTM2136CB	PHTM2200C
31A, 31B, 31C, 31D, 31E, 31F, 31G, 31H	Condensate Trap	110589-01		
32	Front Door	110596-01		
33	Vent connector	107160-01		
42	Side panel	110725-01	111565-01	
45, 46	Wall brackets	110882-01		
Not shown	Thumb screw	106033-01		

21 Service Parts *(continued)*

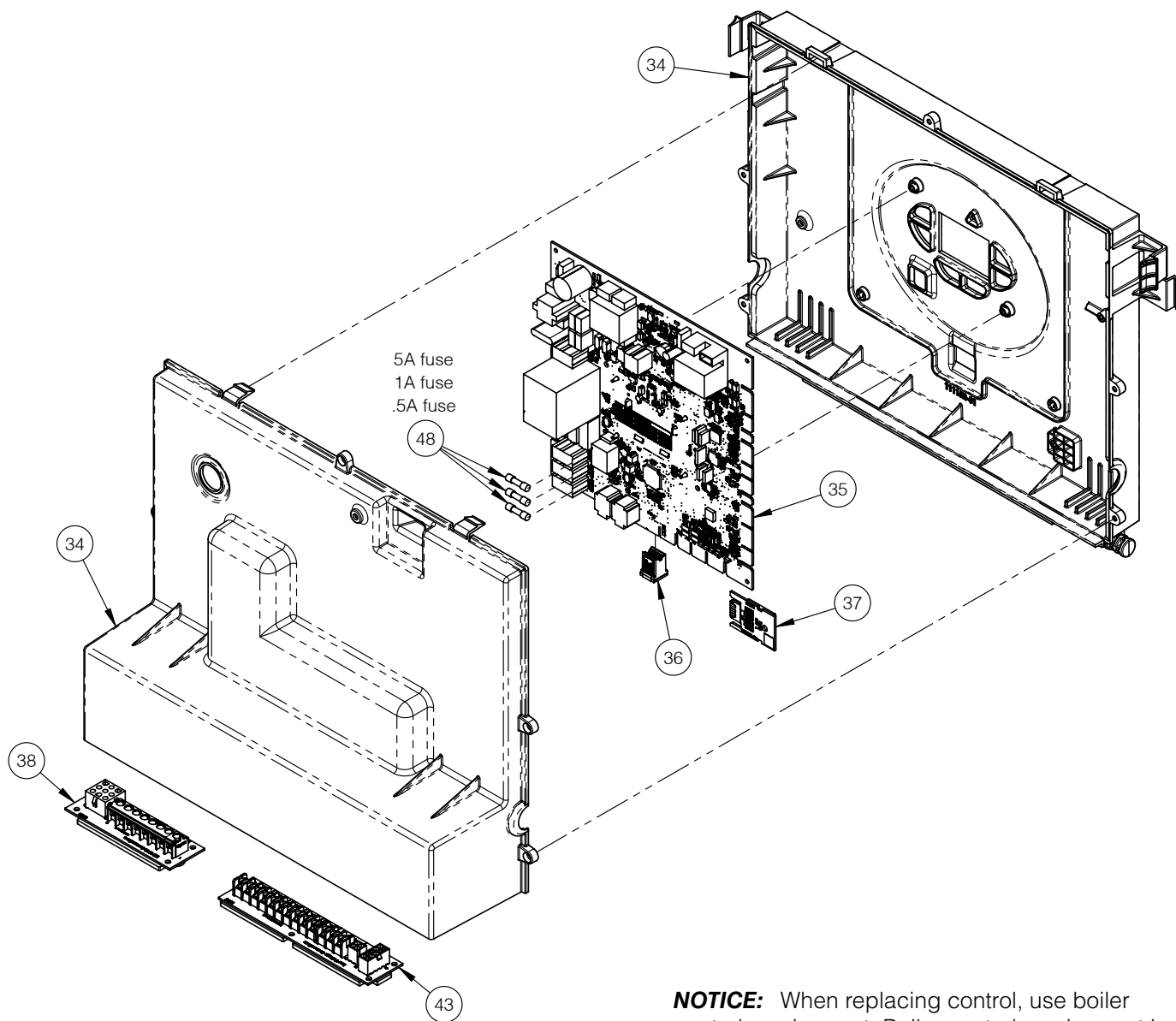

NOTICE: When replacing control, use boiler control service part. Boiler control service part is compatible for all models. Factory installed control is only compatible with purchased boiler.

Key No.	Description	Part Number		
		PHTM2136C	PHTM2136CB	PHTM2200C
34	Control Enclosure	111597-01		
35	Boiler Control	111974-01		
36	BCC	Contact Velocity Boiler Works; Provide boiler serial number		
37	Model Key			
38	120 VAC Connection Board	110726-01		
43	Low Voltage Connection Board	110594-01		
48	Fuse, 0.5A, 5 x 20 mm, 250V, Slow Blow	111420-01		
	Fuse, 1.0A, 5 x 20 mm, 250V, Slow Blow			
	Fuse, 5.0A, 5 x 20 mm, 250V, Slow Blow			

21 Service Parts *(continued)*



39

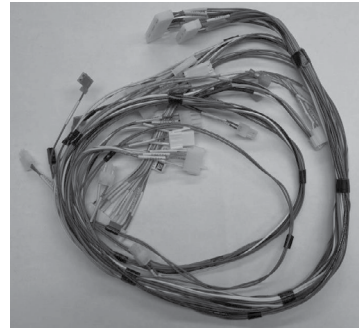

40A

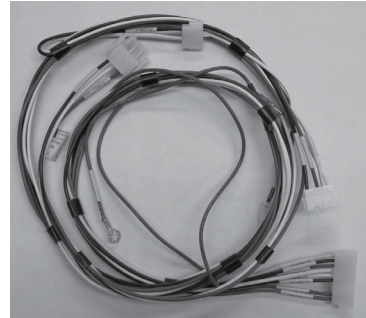

40B

Key No.	Description	Part Number		
		PHTM2136C	PHTM2136CB	PHTM2200C
39	Ignition Harness	110598-01		
40A	Main Control Harness	110599-01		
40B	Power Harness			

22 Accessories

Key No.	Description	Part Number		
		PHTM2136C	PHTM2136CB	PHTM2200C
Not Shown	2 in. CPVC/PVC Vent Kit Starter	107039-01		
	3 in. CPV/PVC Vent Kit includes vent increaser materials	111945-01		
	Condensate Neutralizer Kit	101867-01		
	Auto Reset LWCO, Hydrolevel 1100 with H5 cable	105591-01		
	Manual Reset LWCO Hydrolevel 1100M with H5 cable	108182-01		
	CSD-1 Kit	108183-01		
	Tempering Valve, 70-145F, ASSE 1017, 3/4 in. sweat	108042-01		
	Fernox Alphi-11 antifreeze with inhibitor (5 gal.)	108862-01		
	Hydronic System Corrosion and Lime scale Inhibitor	108863-01		
	Header Sensor/Recirculation Sensor	108703-01		
	Outdoor Temperature Sensor	108681-01		
	Floor Stand	111576-01		
	Noise Attenuator	N/A	111588-01	
	Altitude Conversion Kit (LP installations above 2,000 ft. (610 m))	N/A	111745-01	
	PAT-Connect Bluetooth Adapter	111668-01		
	Heat Exchanger Cleaning Kit	111705-01		
	Heat Exchanger Cleaning Hand Tool	111786-01		

Appendix A Combination Refrigeration/Heating System

1. If boiler is used in connection with refrigeration systems, boiler must be installed with chilled medium piped in parallel with the heating boiler using appropriate valves to prevent chilled medium from entering boiler. See Figure A-1. Also consult Residential Hydronic Heating Installation and Design I=B=R Guide.
2. If boiler is connected to heating coils located in air handling units where they may be exposed to refrigerated air, boiler piping must be equipped with flow control valves or other automatic means to prevent gravity circulation of boiler water during operation of cooling system.

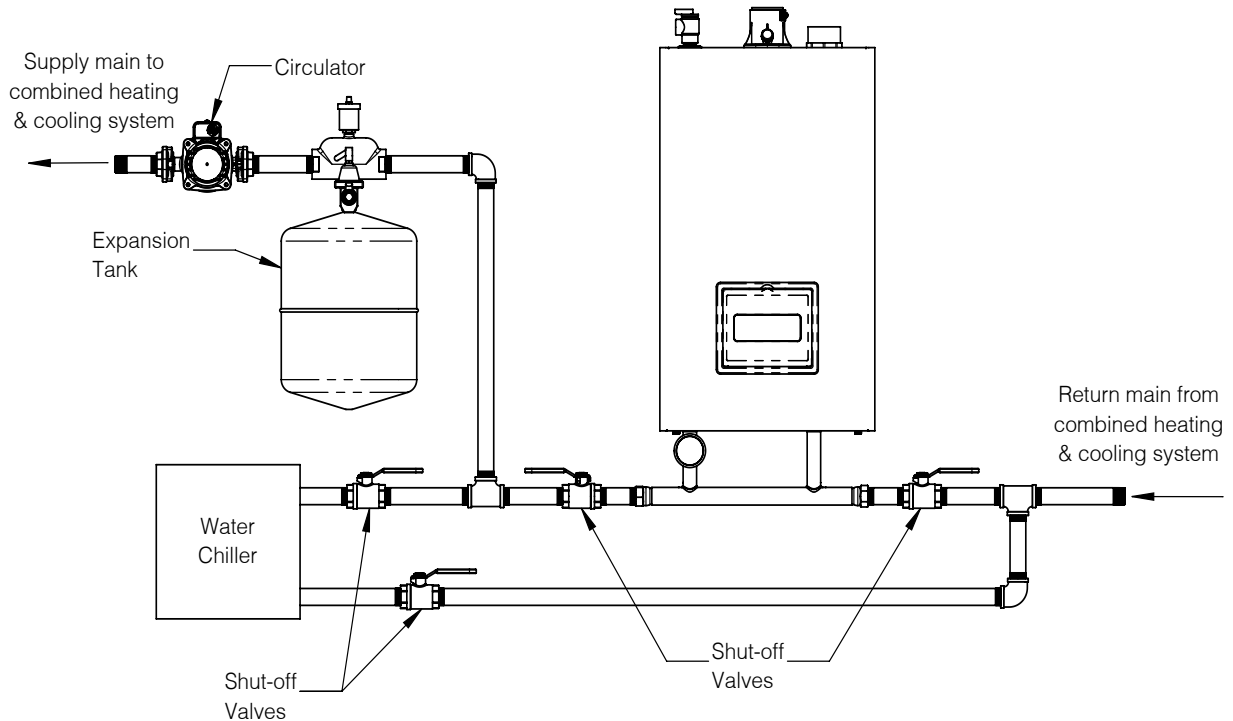

Figure A-1: Isolated Boiler from Refrigeration System

Appendix B Water Quality and Boiler Additives

The heat exchanger used in this boiler is made from stainless steel coils having relatively narrow waterways. Once filled with water, it will be subjected to effects of corrosion as well as fouling from any debris introduced from the system. Take the following precautions to minimize chance of severe heat exchanger damage caused by corrosion and/or overheating.

1. Flush system before connecting boiler.

In a replacement installation, flushing system will remove impurities, such as sediment, solder flux, metal shavings and traces of old boiler additives. Even if system is new, do not omit this step – new systems will contain flux and may even contain other impurities listed above.

Flush system completely and repeat if necessary to completely remove these contaminants. If necessary, a cleaning agent may be used to assist in system cleaning. See Section 15 Start-up and Checkout for recommended cleaners.

2. Make sure the system is tight-

this is the single most important guideline.

Tap water contains dissolved oxygen which causes corrosion. In a tight system, this oxygen comes out of solution and is quickly removed from system through automatic air vent. System then remains essentially free of oxygen.

If system is not tight, however, frequent additions of make-up water can expose heat exchanger to oxygen on a continuous basis. In addition, frequent additions of hard make-up water can cause calcium deposits to collect in heat exchanger, causing severe damage. To minimize additions of make-up water.

- A. Inspect system thoroughly for leaks before putting it into service.
- B. If system includes underground piping or other piping in which a leak might go undetected, consider isolating boiler from the system with a heat exchanger.
- C. Make sure expansion tank is properly sized and in good condition, if it is not, safety relief valve may open frequently, resulting in regular additions of make-up water.
- D. If an automatic fill valve is installed, installation of a water meter in fill line is strongly recommended so routine additions of make-up water can be detected and their cause corrected.

3. Non-metallic tubing - even if system is tight, oxygen can be introduced into system through some types of non-metallic tubing used in radiant or snow melt systems.

Other non-metallic tubing is equipped with an oxygen barrier to prevent migration of oxygen into water. If boiler is to be installed in a system containing non-metallic tubing without an oxygen barrier, it must be isolated from boiler with a heat exchanger.

4. Water chemistry, antifreeze, and boiler water additives – improper boiler water chemistry can cause the heat exchanger damage described above, as well as deterioration.
5. Avoid use of petroleum based boiler additives and ester-based oils/lubricants. These can attack seals in both boiler and system.

Freeze Protection

If this freeze protection is required, use the following or its equivalent:

- A. Fernox Alphi-11
- B. Sentinel X500 Inhibited Polypropylene Glycol

1. Refer to antifreeze manufacturer's instructions for required dosage. In general these products are a blend of glycol (for freeze protection) and inhibitors (to protect glycol from attacking metallic system components).
2. Do not add any more antifreeze than is necessary to protect system from freeze damage.
3. Maximum antifreeze concentration 50%.
4. Test antifreeze and inhibitor concentration annually.
 - A. Inhibitor concentration test kit for Fernox Protector F1, 25 tests per kit. P/N 101148-01.
 - B. Inhibitor, Fernox Protector F1, 1 pint (500 mL) P/N 101147-01.
5. Allowance must be made for additional expansion of glycol solution.
6. Fernox products are available from:

Alent PLC Consumer Products Division
4100 6th Avenue
Altoona, PA 16602
Tel: (972) 547-6002
Email: fernox_usa@alent.com
7. Sentinel products are available from:

Douglas Products and Packaging
1550 E. Old 210 Highway
Liberty, MO 64068
Tel: (877) 567-2560 (Toll Free) and/or selected HVAC distributors

Appendix C Special Requirements For Side-Wall Vented Appliances In The Commonwealth of Massachusetts

IMPORTANT

The Commonwealth of Massachusetts requires compliance with regulation 248 CMR 4.00 and 5.00 for installation of side-wall vented gas appliances as follows:

(a) For all side wall horizontally vented gas fueled equipment installed in every dwelling, building or structure used in whole or in part for residential purposes, including those owned or operated by the Commonwealth and where the side wall exhaust vent termination is less than seven (7) ft. above finished grade in the area of the venting, including but not limited to decks and porches, the following requirements shall be satisfied:

1. **INSTALLATION OF CARBON MONOXIDE DETECTORS.** At the time of installation of the side wall horizontal vented gas fueled equipment, the installing plumber or gas fitter shall observe that a hard wired carbon monoxide detector with an alarm and battery back-up is installed on the floor level where the gas equipment is to be installed. In addition, the installing plumber or gas fitter shall observe that a battery operated or hard wired carbon monoxide detector with an alarm is installed on each additional level of the dwelling, building or structure served by the side wall horizontal vented gas fueled equipment. It shall be the responsibility of the property owner to secure the services of qualified licensed professionals for the installation of hard wired carbon monoxide detectors.

a. In the event that the side wall horizontally vented gas fueled equipment is installed in a crawl space or an attic, the hard wired carbon monoxide detector with alarm and battery back-up may be installed on the next adjacent floor level.

b. In the event that the requirements of this subdivision can not be met at the time of completion of installation, the owner shall have a period of thirty (30) days to comply with the above requirements; provided, however, that during said thirty (30) day period, a battery operated carbon monoxide detector with an alarm shall be installed.

2. **APPROVED CARBON MONOXIDE DETECTORS.** Each carbon monoxide detector as required in accordance with the above provisions shall comply with NFPA 720 and be ANSI/UL 2034 listed and IAS certified.

3. **SIGNAGE.** A metal or plastic identification plate shall be permanently mounted to the exterior of the building at a minimum height of eight (8) ft. above grade directly in line with the exhaust vent terminal for the horizontally vented gas fueled heating appliance or equipment. The sign shall read, in print size no less than one-half (1/2) inch in size, "GAS VENT DIRECTLY BELOW. KEEP CLEAR OF ALL OBSTRUCTIONS".

4. **INSPECTION.** The state or local gas inspector of the side wall horizontally vented gas fueled equipment shall not approve the installation unless, upon inspection, the inspector observes carbon monoxide detectors and signage installed in accordance with the provisions of 248 CMR 5.08(2)(a)1 through 4.

(b) **EXEMPTIONS:** The following equipment is exempt from 248 CMR 5.08(2)(a)1 through 4:

1. The equipment listed in Chapter 10 entitled "Equipment Not Required To Be Vented" in the most current edition of NFPA 54 as adopted by the Board; and

2. Product Approved side wall horizontally vented gas fueled equipment installed in a room or structure separate from the dwelling, building or structure used in whole or in part for residential purposes.

Appendix C Special Requirements For Side-Wall Vented Appliances In The Commonwealth of Massachusetts *(continued)*

(c) MANUFACTURER REQUIREMENTS - GAS EQUIPMENT VENTING SYSTEM PROVIDED. When the manufacturer of Product Approved side wall horizontally vented gas equipment provides a venting system design or venting system components with the equipment, the instructions provided by the manufacturer for installation of the equipment and the venting system shall include:

1. Detailed instructions for the installation of the venting system design or the venting system components; and
2. A complete parts list for the venting system design or venting system.

(d) MANUFACTURER REQUIREMENTS - GAS EQUIPMENT VENTING SYSTEM NOT PROVIDED. When the manufacturer of a Product Approved side wall horizontally vented gas fueled equipment does not provide the parts for venting the flue gases, but identifies "special venting systems", the following requirements shall be satisfied by the manufacturer:

1. The referenced "special venting system" instructions shall be included with the appliance or equipment installation instructions; and
2. The "special venting systems" shall be Product Approved by the Board, and the instructions for that system shall include a parts list and detailed installation instructions.

(e) A copy of all installation instructions for all Product Approved side wall horizontally vented gas fueled equipment, all venting instructions, all parts lists for venting instructions, and/or all venting design instructions shall remain with the appliance or equipment at the completion of the installation.

Appendix D Code Required Text

See Section 5 Locating Boiler: Remove Existing Boiler for context of following text:

Les instructions doivent comprendre le mode opératoire d'essai indiqué ci-dessous:

Au moment du retrait d'une chaudière existante, les mesures suivantes doivent être prises pour chaque appareil toujours raccordé au système d'évacuation commun et qui fonctionne alors que d'autres appareils toujours raccordés au système d'évacuation ne fonctionnent pas:

1. Sceller toutes les ouvertures non utilisées du système d'évacuation.
2. Inspecter de façon visuelle le système d'évacuation pour déterminer la grosseur et l'inclinaison horizontale qui conviennent et s'assurer que le système est exempt d'obstruction, d'étranglement, de fuite, de corrosion et autres défaillances qui pourraient présenter des risques.
3. Dans la mesure du possible, fermer toutes les portes et les fenêtres du bâtiment et toutes les portes entre l'espace où les appareils toujours raccordés au système d'évacuation sont installés et les autres espaces du bâtiment. Mettre en marche les sècheuses, tous les appareils non raccordés au système d'évacuation commun et tous les ventilateurs d'extraction comme les hottes de cuisinière et les ventilateurs des salles de bain. S'assurer que ces ventilateurs fonctionnent à la vitesse maximale. Ne pas faire fonctionner les ventilateurs d'été. Fermer les registres des cheminées.
4. Mettre l'appareil inspecté en marche. Suivre les instructions d'allumage. Régler le thermostat de façon que l'appareil fonctionne de façon continue.
5. Faire fonctionner le brûleur principal pendant 5 min ensuite, déterminer si le coupe-tirage déborde à l'ouverture de décharge. Utiliser la flamme d'une allumette ou d'une chandelle ou la fumée d'une cigarette, d'un cigare ou d'une pipe.
6. Une fois qu'il a été déterminé, selon la méthode indiquée ci-dessus, que chaque appareil raccordé au système d'évacuation est mis à l'air libre de façon adéquate. Remettre les portes et les fenêtres, les ventilateurs, les registres de cheminées et les appareils au gaz à leur position originale.
7. Tout mauvais fonctionnement du système d'évacuation commun devrait être corrigé de façon que l'installation soit conforme au National Fuel Gas Code, ANSI Z223.1/ NFPA 54 et (ou) aux codes d'installation CAN/CSA-B149.1. Si la grosseur d'une section du système d'évacuation doit être modifiée, le système devrait être modifié pour respecter les valeurs minimales des tableaux pertinents de l'appendice F du National Fuel Gas Code, ANSI Z223.1/ NFPA 54 et (ou) les codes d'installation CAN/CSA-B149.1.
8. Les instructions d'installation du système d'évacuation doivent préciser que les sections horizontales doivent être supportées pour prévenir le fléchissement. Les méthodes et les intervalles de support doivent être spécifiés. Les instructions doivent aussi indiquer les renseignements suivants:
9. les chaudières de catégories I, II et IV doivent présenter des tronçons horizontaux dont la pente montante est d'au moins ¼ po par pied (21 mm/m) entre la chaudière et l'évent;
10. les chaudières de catégories II et IV doivent être installées de façon à empêcher l'accumulation de condensat; et
11. si nécessaire, les chaudières de catégories II et IV doivent être pourvues de dispositifs d'évacuation du condensat.
12. ATTENTION. Au moment de l'entretien des commandes, étiquetez tous les fils avant de les débrancher. Les erreurs de câblage peuvent nuire au bon fonctionnement et être dangereuses.
13. après l'entretien

**Velocity Boiler Works, LLC
P.O. Box 14818
3633 I Street
Philadelphia, PA 19134**