



PHANTOM[®]

**Stainless steel, condensing,
gas-fired hot water boiler**



NEW AFUE up to 95%

- Stainless steel water tube heat exchanger
- Five sizes - 80, 100, 120, 150, and 180 MBH input
- Compact wall mount installation
- Outdoor reset with included sensor
- Modulating burner with 5:1 turndown ratio
- Honeywell SOLA control with touch screen user interface
- Vent adapter allows for CPVC/PVC or single wall polypropylene venting
- Preinstalled boiler pump

“EZ” ACCESSORIES FOR THE PHANTOM[®]

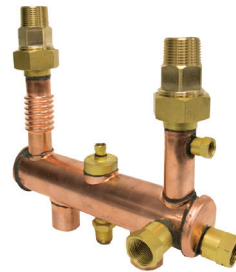

“EZ Loop” Low Loss Header

The factory-designed “EZ Loop” Low Loss Header is a piping solution that helps contractors to complete the job with speed and accuracy, saving time and money.

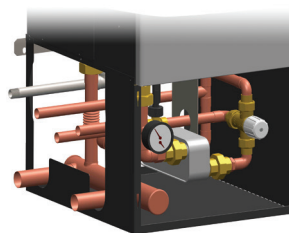

“EZ” Combi-Kit

The “EZ” Combi-Kit includes a mixing valve, plate heat exchanger and the EZ Loop Low Loss Header, providing a simple way to add domestic hot water capabilities to the Phantom[®] 150 and 180.

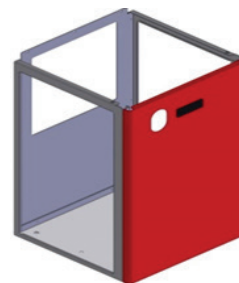

“EZ” Base

The “EZ” Base is the final touch for a clean and attractive installation. It includes adjustable feet and works great with the “EZ Loop” Low Loss Header and the “EZ” Combi-Kit.

Need a larger size?
PHANTOM-X
BY CROWN BOILER
available in
210 to 500 MBH input.

**Quality
Value &
Service**

PHANTOM®

TECHNICAL SPECIFICATIONS

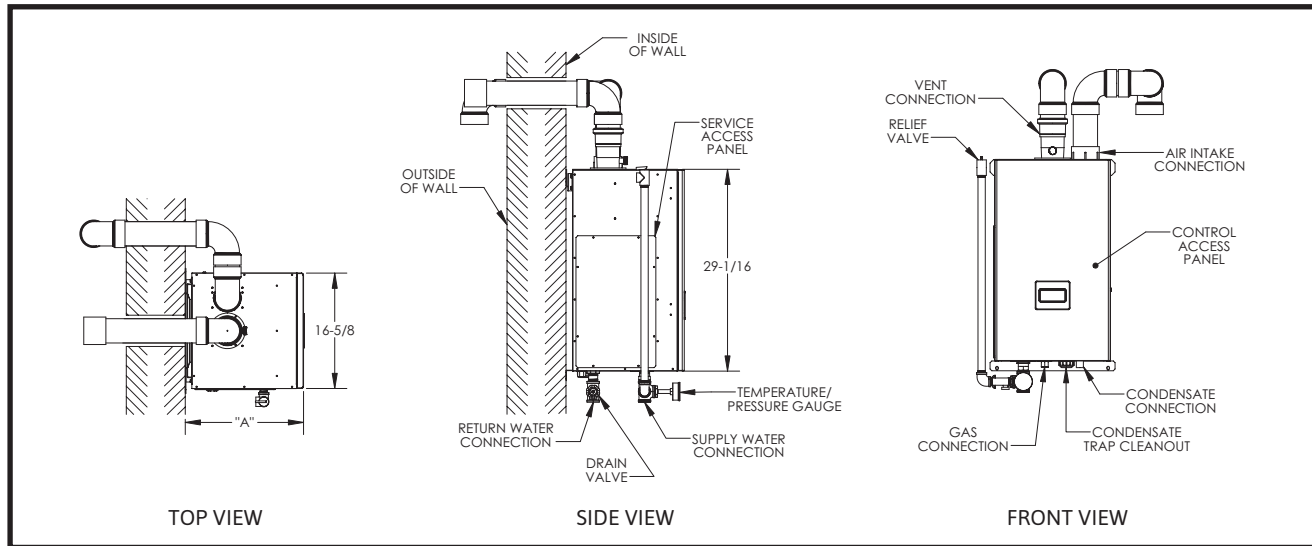

MODEL	MAX. INPUT (MBH)	MIN. INPUT (MBH)	HEATING CAPACITY (MBH)	AHRI NET RATING (MBH)	NEW AFUE (%)	WATER VOLUME (GAL.)	DIM. "A"	SUPPLY & RETURN CONN. SIZE (NPT)	GAS CONN. SIZE (NPT)	APPROX. NET WEIGHT (LBS)
PHNTM080	80	16	74	64	94.0	0.36	17"	1"	1/2"	100
PHNTM100	100	20	92	80	93.3	0.44	17"	1"	1/2"	102
PHNTM120	120	24	112	97	94.0	0.53	17"	1"	1/2"	105
PHNTM150	150	30	142	123	95.0	0.79	21"	1"	1/2"	119
PHNTM180	180	36	170	148	94.0	0.79	21"	1"	1/2"	119

NOTES:

1. De-rate required on some models installed above 2,000 ft., consult factory for details. For Canadian installations over 4,500 ft., consult authority having jurisdiction for guidance. PHNTM080 may not be installed using LP gas above 2,000 ft. PHNTM180 may not be installed using LP gas above 7,800 ft.
2. The Net Water Ratings are based on a piping and pickup allowance of 1.15.
3. The manufacturer should be consulted before selecting a boiler for installations having unusual piping and pickup requirements, such as intermittent system operation, extensive piping systems, etc.
4. Refer to manual for system vent length derates.

All Phantom® boiler models include a full two-year parts warranty. A 12-year limited warranty is provided for the heat exchanger. A 5-year and a 10-year extended warranty covering parts and labor are also available. Visit CrownBoiler.com or see your warranty for complete details.

ADDITIONAL FEATURES/BENEFITS

- Selectable domestic hot water priority
- Boiler, system, and domestic hot water pump outputs
- Field convertible to LP gas
- Fuse protection for pump and transformer



The Mega-Stor® indirect water heater utilizes the energy created by your boiler to produce abundant hot water for your home. Mega-Stor water heaters come in a variety of sizes from 26 to 119 gallons to meet a multitude of residential and commercial needs.

Specifications are subject to change without notice.

