

# Crown Boiler Company

## Installation Instructions for FSZ Dropped Header Gravity Return Piping Kit

The following near-boiler piping kits are available from Crown for use with FSZ boilers installed in gravity return systems:

421095 - Dropped Header Gravity Return Near Boiler Piping Kit (FSZ080,100,130)

421096 - Dropped Header Gravity Return Near Boiler Piping Kit (FSZ160)

These kits provide the pipe and fittings needed for the “drop header” piping as listed in Table 1 for the FSZ080, FSZ100 and FSZ130 and in Table 3 for the FSZ160.

### Installation of Dropped Header Gravity Return Piping Kit

- 1) Assemble Dropped Header Gravity Return Piping Kit for the FSZ080, FSZ100 and FSZ130 as shown in Figure 2.
- 2) Assemble Dropped Header Gravity Return Piping Kit for the FSZ160 as shown in Figure 4.
- 3) Tighten unions only after all piping is in the proper position. Use of pipe dope or teflon tape on all threaded surfaces is recommended.



#### **WARNING**

Difference in piping compound and or method may effect pipe alignment.

**TABLE 1: Dropped Header Material List for FSZ080, FSZ100 and FSZ130 Boilers**

Item	Fitting Description	Quantity
1	2" x 12" Nipple	2
2	2" Union	3
3	2" x 6" Nipple	2
4	2" Elbow	5
5	2" x 15" Nipple	2
6	2" x 7" Nipple	2
7	2" x 3" Nipple (FSZ080 and FSZ100) or 2" x 9" Nipple (FSZ130)	1
8	2" x 4-1/2" Nipple	3
9	2" Tee	2
10	2" - 1-1/2" Reducing Elbow	1
11	1-1/2" x 8" Nipple	1
12	1-1/2" Union	1
13	1-1/2" x 5-1/2" Nipple	1
14	1-1/2" Wye	1
15	1-1/2" - 1-1/4" Bushing	1
16	1-1/4" x 22" Nipple	1
17	1-1/4" x 3/4" x 1-1/4" Tee	2
18	1-1/4" x 12" Nipple	1
19	1-1/4" x 1-1/4" x 3/4" Tee	1
20	1-1/4" x 7" Nipple	1
21	1-1/4" x Close Nipple	2
22	1-1/4" Union	1
23	3/4" Plug	1

NOTE: Item 15 shown at boiler is installed on the boiler at the factory.

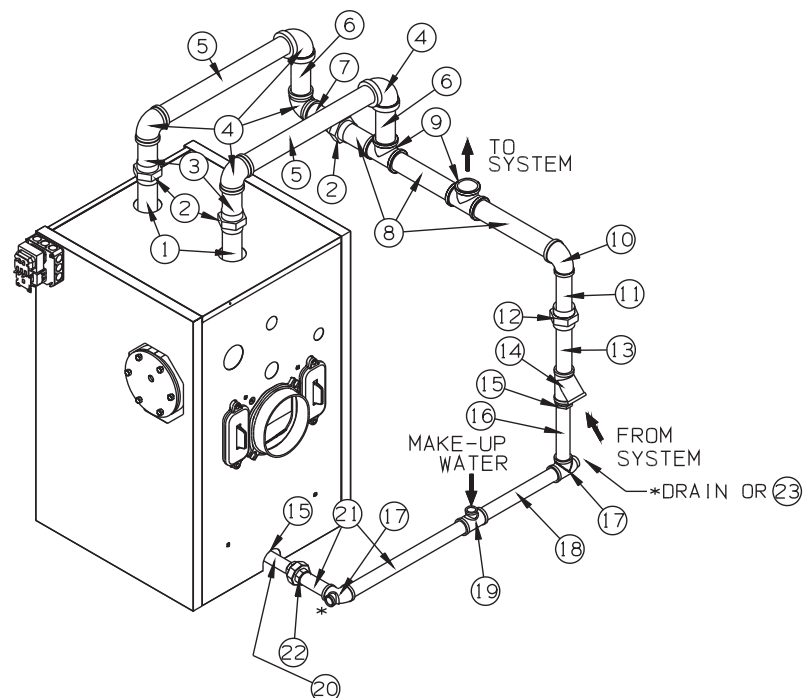

**FIGURE 2: Dropped Header Gravity Return Diagram for FSZ080, FSZ100 and FSZ130**

**TABLE 3: Dropped Header Material List for FSZ160 Boilers**

Item	Fitting Description	Quantity
1	2" x 12" Nipple	2
2	2" Union	3
3	2" x 6" Nipple	2
4	2" Elbow	4
5	2" x 15" Nipple	2
6	2" x 7" Nipple	2
7	3" x 2" Reducing Elbow	2
8	3" x 9" Nipple	1
8A	3" x 10" Nipple	1
9	3" Union	1
10	3" x 5" Nipple	2
11	3" x 3" x 2" Tee	1
12	3" Tee	1
13	2" x 7" Nipple	1
13A	2" x 5" Nipple	1
14	2" Wye	1
15	2" - 1-1/2" Bushing	1
16	1-1/2" x 20-3/4" Nipple	1
17	1-1/2" x 1-1/2" x 3/4 Tee	1
18	1-1/2" x 5" Nipple	1
19	1-1/2" x 3/4" x 1-1/2" Tee	2
20	1-1/2" x 4" Nipple	1
21	1-1/2" Union	1
22	1-1/2" x 8" Nipple	2
23	3/4" Plug	1

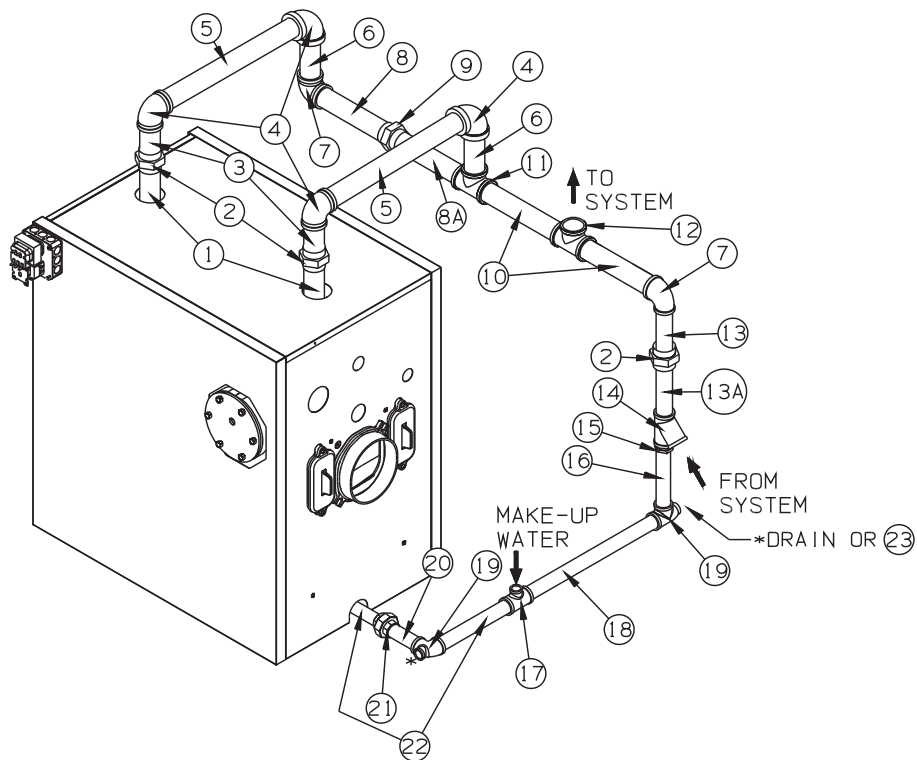

**FIGURE 4: Dropped Header Gravity Return Diagram for FSZ160**



---

Manufacturer of Hydronic Heating Products  
P.O. Box 14818 3633 I. Street  
Philadelphia, PA 19134  
[www.crownboiler.com](http://www.crownboiler.com)