

# CROWN Boiler Co.

D E S I G N E D T O L E A D

## BWC Series

### Pedestal Kit Installation Instructions

**WARNING:** Improper installation, adjustment, alteration, service or maintenance can cause property damage, injury, or loss of life. For assistance or additional information, consult a qualified installer, service agency or the gas supplier. Read these instructions, and those supplied with the boiler itself, carefully before installing.

This kit allows the BWC070, BWC090, and BWC120 to be floor mounted. See Figure 1 for basic pedestal dimensions. The floor must be level, un-carpeted, and may be either combustible or non-combustible. Refer to the installation instructions supplied with the boiler, as well as applicable local codes, for additional location requirements.

Gas and system return piping can be routed through either the large obround knockouts on the sides of the pedestal or through the rectangular opening in the back. The condensate drain hose can be routed through the small obround openings located in the pedestal sides or back. It is recommended that the condensate trap, and any piping located inside the pedestal, be mounted on the boiler prior to attaching the pedestal.

Electrical wiring may be routed through either the 7/8" knockouts in the side panels or through the rectangular opening in the rear of the pedestal

Attach the pedestal to the boiler using the four 1/4-20 nuts and bolts supplied as shown in Figure 2. After tightening these bolts, raise the boiler onto its feet, move to its final position and level using the adjustable leveling feet provided on the base. Follow the installation manual supplied with the boiler to complete the installation.

#### CAUTION

This pedestal is **not** a listed electrical enclosure. Protect all wiring passing through the pedestal from abrasion and strain as required by the National Electric Code (ANSI/NFPA 70) or applicable local codes.

SEE BOILER INSTALLATION MANUAL FOR DIMENSIONS NOT SHOWN

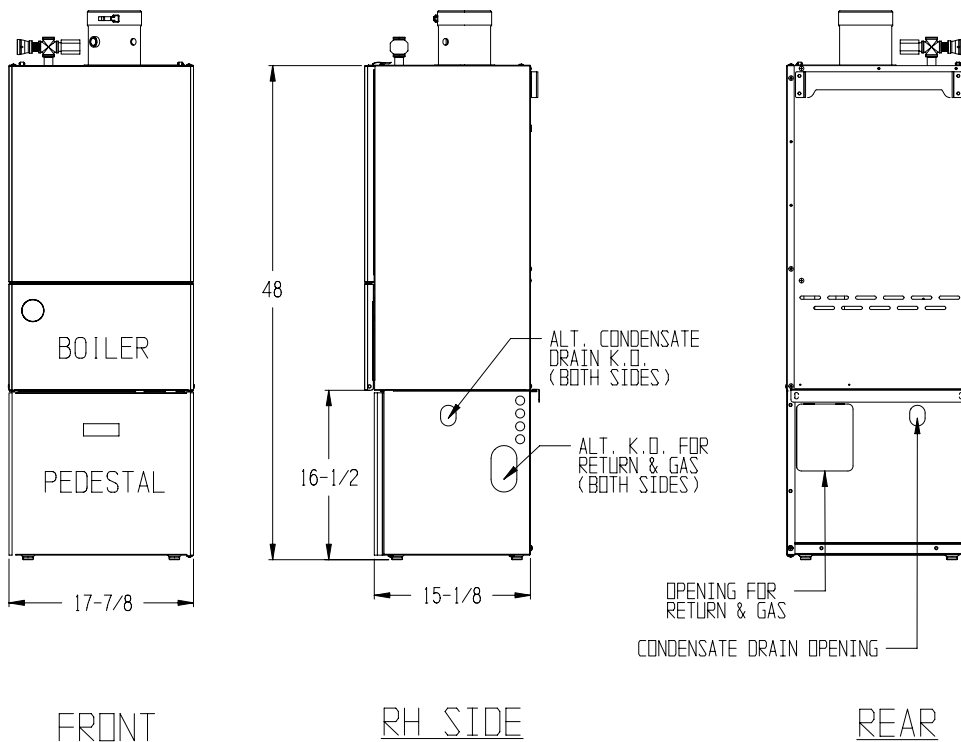

Figure 1: Basic Pedestal Configuration (Shown with Boiler Mounted)

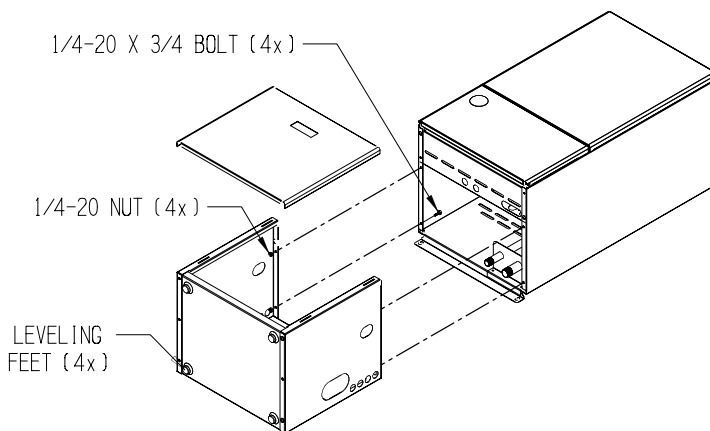

Figure 2: Assembling Pedestal to Boiler

# CROWN Boiler Co.

Manufacturer of Hydronic Heating Products

P.O. Box 14818 3633 I. Street

Philadelphia, PA 19134

Tel: (215) 535-8900 • Fax: (215) 535-9736 • [www.crownboiler.com](http://www.crownboiler.com)

PN: 980059

Rev 0