



# BALI® Gas-Fired Hot Water Boiler

Designed with through-the-wall venting for homes without chimneys or where the chimney cannot be used.



## INTEGRATED BOILER CONTROL

Features temperature control, relay, and ignition functions in a single module. Includes additional circulator output for a second heating zone or an indirect water heater like the Mega-Stor II®.

**Available Upgrade Option**

- 24 Volt Low Water Cutoff

- Cast iron heat exchanger and stainless steel burners
- Integral fan for sidewall venting
- Fiberglass insulation to minimize heat loss
- Designed for installation on combustible floors
- Six sizes from 61 to 229 MBH
- Limited lifetime warranty

See back side for piping configurations.



# BWF SERIES - BALI®

## TECHNICAL SPECIFICATIONS

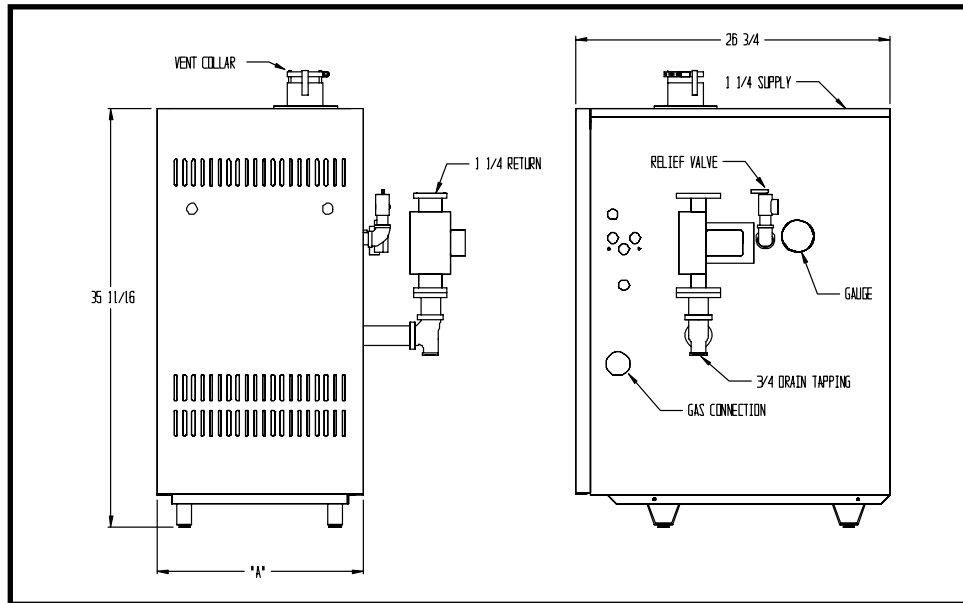

CROWN MODEL NUMBER	NATURAL AND LP GAS					DIMENSIONS (IN)		WATER CONTENT (GAL)	SHIPPING WEIGHT (LBS)
	NO. OF SECTIONS	INPUT (MBH)	HEATING CAPACITY (MBH)	AHRI NET WATER RATING (MBH)	AFUE (%)	"A"	VENT DIAMETER		
BWF061	3	61	51	44	83.3	14-1/4	3	3.2	282
BWF095	4	95	78	68	83.1	17-1/2	3	4.0	332
BWF128	5	128	106	92	82.8	20-3/4	3	4.7	382
BWF162	6	162	134	117	82.5	24	3	5.5	432
BWF195	7	195	161	140	82.3	27-1/4	4	6.3	482
BWF229	8	229	189	164	82.0	30-1/2	4	7.0	532

- Altitudes above 2,000 ft. - ratings should be reduced at a rate of 4% for each 1,000 ft. above sea level (US only)
- The Net Water Ratings are based on a piping and pickup allowance of 1.15.
- The manufacturer should be consulted before selecting a boiler for installations having unusual piping and pickup requirements, such as intermittent system operation, extensive piping systems, etc.

All residential cast iron boiler models include a full one-year warranty. A limited lifetime warranty is provided for the heat exchanger. A 5-year and a 10-year extended warranty covering parts and labor are also available. Visit [VelocityBoilerWorks.com](http://VelocityBoilerWorks.com) or see your warranty for complete details.

### ADDITIONAL FEATURES/BENEFITS

- Optional Category I vent kit
- Gas valve and relays mounted inside the jacket
- Temperature/pressure gauge and drain valve included
- Reliable Honeywell controls



The Mega-Stor II® indirect water heater utilizes the energy created by your boiler to produce abundant hot water for your home. Mega-Stor II water heaters come in a variety of sizes from 26 to 119 gallons to meet a variety of residential and commercial needs. A Horizontal model is also available in 40 and 53 gallon sizes, as well as a Solar model in 79 and 119 gallon sizes.



Specifications are subject to change without notice.

VelocityBoilerWorks.com | Philadelphia PA

BWF-2/17  
PN 980527