



D E S I G N E D T O L E A D

Series 16H

Gas-Fired Natural Draft Hot Water Boilers

INSTALLATION INSTRUCTIONS

These instructions must be affixed on or adjacent to the boiler

Models:

- 16H-340
- 16H-410
- 16H-460
- 16H-505

WARNING: Improper installation, adjustment, alteration, service or maintenance can cause property damage, injury, or loss of life. For assistance or additional information, consult a qualified installer, service agency or the gas supplier. Read these instructions carefully before installing.



Intertek
3050579



Manufacturer of Hydronic Heating Products
P.O. Box 14818 3633 I. Street
Philadelphia, PA 19134
www.crownboiler.com

IMPORTANT INFORMATION - READ CAREFULLY

NOTE: The equipment must be installed in accordance with those installation regulations enforced in the area where the installation is to be made. These regulations shall be carefully followed in all cases. Authorities having jurisdiction shall be consulted before installations are made.

All wiring on boilers installed in the USA shall be made in accordance with the National Electrical Code and/or local regulations.

The following terms are used throughout this manual to bring attention to the presence of hazards of various risk levels, or to important information concerning product life.

DANGER

Indicates an imminently hazardous situation which, if not avoided, will result in death, serious injury or substantial property damage.

CAUTION

Indicates a potentially hazardous situation which, if not avoided, may result in moderate or minor injury or property damage.

WARNING

Indicates a potentially hazardous situation which, if not avoided, could result in death, serious injury or substantial property damage.

NOTICE

Indicates special instructions on installation, operation, or maintenance which are important but not related to personal injury hazards.

DANGER

DO NOT store or use gasoline or other flammable vapors or liquids in the vicinity of this or any other appliance.

If you smell gas vapors, **DO NOT** try to operate any appliance - **DO NOT** touch any electrical switch or use any phone in the building. Immediately, call the gas supplier from a remotely located phone. Follow the gas supplier's instructions or if the supplier is unavailable, contact the fire department.

DO NOT install this boiler on combustible flooring, carpet, concrete over combustible flooring or wood, nor on concrete over any heat affected material such as plastic piping or wiring without a properly installed combustible floor shield.

NOTICE

All Series 16H cast iron boilers are designed, built, marked and tested in accordance with the ASME Boiler and Pressure Vessel Code, Section IV, Heating Boilers. An ASME Data Label is factory applied to each 16H jacket, which indicates the boiler Maximum Allowable working Pressure (MAWP). Each cast iron section is permanently marked with the MAWP listed on the boiler's ASME Data Label. The MAWP for all Series 16H Boilers is 50 psi (Water Only).

It is common and acceptable practice to install these boilers in lower pressure systems, below the boiler MAWP. Therefore, in addition to Safety Relief Valves set for 50 psi, Crown also offers Safety Relief Valves set for 30 psi (By Special Order Only).

WARNING

This boiler requires regular maintenance and service to operate safely. Follow the instructions contained in this manual.

Improper installation, adjustment, alteration, service or maintenance can cause property damage, personal injury or loss of life. Read and understand the entire manual before attempting installation, start-up operation, or service. Installation and service must be performed only by a knowledgeable, experienced, and skilled installer or service agency.

This boiler must be properly vented.

This boiler needs fresh air for safe operation and must be installed so there are provisions for adequate combustion and ventilation air.

The interior of the venting system must be inspected and cleaned before the start of the heating season and should be inspected periodically throughout the heating season for any obstructions. A clean and unobstructed venting system is necessary to allow noxious fumes that could cause injury or loss of life to vent safely and will contribute toward maintaining the boiler's efficiency.

Installation is not complete unless a pressure relief valve is installed into the tapping located on the top of boiler - See the Water Trim and Piping Section of this manual for details.

This boiler is supplied with safety devices which may cause the boiler to shut down and not re-start without service. If damage due to frozen pipes is a possibility, the heating system should not be left unattended in cold weather; or appropriate safeguards and alarms should be installed on the heating system to prevent damage if the boiler is inoperative.

This boiler contains very hot water under high pressure. Do not unscrew any pipe fittings nor attempt to disconnect any components of this boiler without positively assuring the water is cool and has no pressure. Always wear protective clothing and equipment when installing, starting up or servicing this boiler to prevent scald injuries. Do not rely on the pressure and temperature gauges to determine the temperature and pressure of the boiler.

This boiler contains components which become very hot when the boiler is operating. Do not touch any components unless they are cool.

Boiler materials of construction, products of combustion and the fuel contain alumina, silica, heavy metals, carbon monoxide, nitrogen oxides, aldehydes and/or other toxic or harmful substances which can cause death or serious injury and which are known to the state of California to cause cancer, birth defects and other reproductive harm. Always use proper safety clothing, respirators and equipment when servicing or working nearby the appliance.

Failure to follow all instructions in the proper order can cause personal injury or death. Read all instructions, including all those contained in component manufacturers manuals which are provided with the boiler before installing, starting up, operating, maintaining or servicing.

Keep boiler area clear and free from combustible materials, gasoline and other flammable vapors or liquids.

Do not operate boiler with control which has been subject to water.

All cover plates, enclosures and guards must be in place at all times.

NOTICE

This boiler has a limited warranty. It is the responsibility of the installing contractor to see that all controls are correctly installed and are operating properly when the installation is complete.

USA boilers built for installation at altitudes greater than 2,000 feet above sea level have been specially orificed to reduce gas input rate 4 percent per 1,000 feet above sea level per the National Fuel Gas Code, NFPA 54/ANSI Z223.1, Section 8.1.2 and Appendix F.

Table of Contents

I. Pre-Installation.....	6
II. Boiler Assembly.....	8
III. Gas Control System Assembly	15
IV. Water Trim and Piping.....	19
V. Gas Piping.....	23
VI. Venting.....	25
VII. Electrical.....	28
VIII. System Start-up.....	36
IX. Service & Troubleshooting	42
X. Repair Parts.....	49

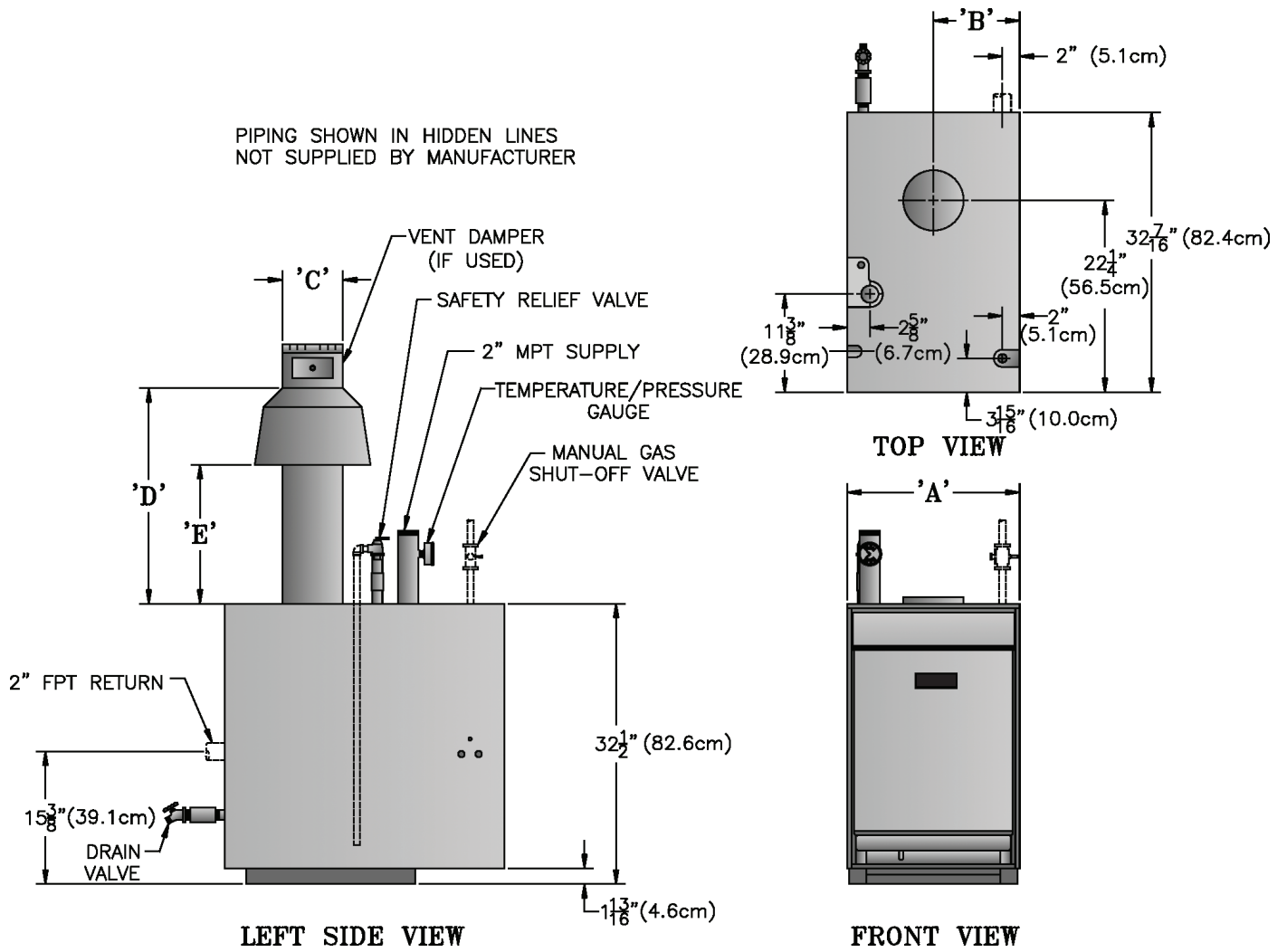

Figure 1: Dimensional Data

Table 1: Dimensional Data

Boiler Model	Dimensions (Inches)					Recommended Chimney Size (Round)	Water Content (Gallons)	Approx. Shipping Weight (LB.)
	A	B	C	D	E			Knockdown
16H-340	27-1/2	13-3/4	8	27-13/16	18	8" dia. x 15 ft.	15.9	870
16H-410	31-1/4	15-5/8	9	30-13/16	20	8" dia. x 15 ft.	17.9	955
16H-460	35	17-1/2	10	33-1/2	22	10" dia. x 15 ft.	19.9	1050
16H-505	38-3/4	19-3/8	10	33-1/2	22	10" dia. x 15 ft.	21.9	1150

I. Pre-Installation

WARNING

Carefully read all instructions before installing boiler. Failure to follow all instructions in proper order can cause personal injury or death.

- A. Inspect shipment** carefully for any signs of damage. All equipment is carefully manufactured, inspected and packed. Our responsibility ceases upon delivery of boiler to carrier in good condition. Any claim for damage or shortage in shipment must be filed immediately against carrier by consignee. No claims for variances or shortages will be allowed by Boiler Manufacturer, unless presented within sixty (60) days after receipt of equipment.
- B. Installation must conform** to the requirements of the authority having jurisdiction. In the absence of such requirements, installation must conform to the *National Fuel Gas Code*, NFPA 54/ANSI Z223.1. Where required by the authority having jurisdiction, the installation must conform to the *Standard for Controls and Safety Devices for Automatically Fired Boilers*, ANSI/ASME No CSD-1.
- C. Provide clearance between combustible material** and boiler jacket (following clearances are minimums):
1. 16H-340: listed for Alcove installation
 - a. Front: 18"
 - b. Top: 36"
 - c. Draft hood, rear, sides and flue connector: 6"

WARNING

Appliance is design certified for installation on noncombustible flooring only. For installation on combustible flooring only when installed on special base listed in Table 2. Boiler must not be installed on carpeting. When boiler is installed on concrete which is over a material that is subject to melting (PVC, PEX radiant tubing, etc.), the special base must be used. A concrete pad is not sufficient to protect combustible flooring.

Table 2: Special Base Required for Installation on Combustible Flooring

Boiler Model	Special Base Part Number
16H-340	61816075
16H-410	61816085
16H-460	61816095
16H-505	61816105

2. 16H-410-16H-505: for installation in room which is large in comparison with size of boiler.
 - a. Front: 18"
 - b. Top: 51½"
 - c. Draft hood, rear, sides, and flue connector: 6"
- D. Provide clearance for servicing** and proper operation (following clearances are recommended and may be reduced to minimum clearances shown above):
1. Single boiler, 16H-340, Front: 24" (61.0 cm)
 2. Single boiler, 16H-410-16H-505, Front: 48" (122.0 cm)
 3. Multiple/modular boiler, Sides: 1" (2.5 cm)
- E. Install boiler on level floor** as close to chimney as possible. For basement installation provide a solid base such as concrete or masonry construction if floor is not level or if water may be encountered on floor around boiler.
- F. Protect gas ignition system components** from water (dripping, spraying, rain, etc.) during boiler operation and service (circulator replacement, control replacement, etc.).
- G. Provide combustion and ventilation air** in accordance with applicable provisions of local building codes, or the *National Fuel Gas Code*, NFPA 54/ANSI Z223.1, *Air for Combustion and Ventilation*.

WARNING

Adequate combustion and ventilation air must be provided to assure proper combustion.

The following guideline is based on the *National Fuel Gas Code*, NFPA 54/ANSI Z223.1.

1. Determine volume of space (boiler room). Rooms communicating directly with space (through permanent openings not furnished with doors) are considered part of space.

$$\text{Volume [ft}^3\text{]} = \text{Length [ft]} \times \text{Width [ft]} \times \text{Height [ft]}$$
2. Determine Total Input of all appliances in space. Round result to nearest 1,000 Btu per hour (Btuh).
3. Determine type of space. Divide Volume by Total Input.
 - a. If result is greater than or equal to 50 ft³ per 1,000 Btuh, space is considered an *unconfined space*.
 - b. If result is less than 50 ft³ per 1,000 Btuh, space is considered a *confined space*.
4. Determine building type. A building of *unusually tight construction* has the following characteristics:
 - a. Walls and ceiling exposed to outside atmosphere have a continuous water vapor retarder with a

- rating of 1 perm or less with openings gasketed and sealed, and
- b. Weather-stripping has been added on openable windows and doors, and
 - c. Caulking or sealants applied in joints around window and door frames, between sole plates and floors, between wall-ceiling joints, between wall panels, at plumbing and electrical penetrations, and at other openings.
5. For boiler located in an *unconfined space in a building of other than unusually tight construction*, adequate combustion and ventilation air is normally provided by fresh air infiltration through cracks around windows and doors.
 6. For boiler located in an *unconfined space in a building of unusually tight construction* or in a *confined space*, provide outdoor air through permanent opening(s) which communicate directly or by duct with the outdoors or spaces (crawl or attic) freely communicating with the outdoors. Minimum dimension of air opening(s) is 3" (7.6 cm).
 - a. Two permanent openings: Locate one opening within 12 inches (30.5 cm) of top of space. Locate remaining opening within 12 inches (30.5 cm) of bottom of space. Size each opening per following:
 - i. Direct communication with outdoors. Minimum free area of each opening must be 1 square inch per 4,000 Btu per hour input of all equipment in space.
 - ii. Vertical ducts. Minimum free area of each opening must be 1 square inch per 4,000 Btu per hour input of all equipment in space. Duct cross-sectional area shall be same as opening free area.
 - iii. Horizontal ducts. Minimum free area of each opening must be 1 square inch per 2,000 Btu per hour input of all equipment in space. Duct cross-sectional area shall be same as opening free area.
 - b. One permanent opening shall be permitted where the boiler has clearances of at least 1" (2.5 cm) from the sides and rear and 6" (15.2 cm) from the front. Locate the opening within 12 inches (30.5 cm) of top of space. Size opening per following:
 - i. Minimum free area of 1 square inch per 3,000 Btu per hour input of all equipment in space.
 - ii. Free area shall not be less than the sum of the areas of all vent connectors in the confined space.

Alternate method for boiler located within confined space. Use indoor air if two permanent openings communicate directly with additional space(s) of sufficient volume such that combined volume of all spaces meet criteria for unconfined space. Size each opening for minimum free area of 1 square inch per 1,000 Btu per hour input of all equipment in spaces, but not less than 100 square inches.

7. Ventilation Duct Louvers and Grilles. Equip outside openings with louvers to prevent entrance of rain and snow, and screens to prevent entrance of insects and rodents. Louvers and grilles must be fixed in open position or interlocked with equipment to open automatically before burner operation. Screens must not be smaller than ¼ inch mesh.

Consider the blocking effect of louvers, grilles and screens when calculating the opening size to provide the required free area. If free area of louver or grille is not known, assume wood louvers have 20-25 percent free area and metal louvers and grilles have 60-75 percent free area.

8. For Specially Engineered Installations. The above requirements shall be permitted to be waived where special engineering, consistent with good engineering practice and approved by the authority having jurisdiction, provides an adequate supply of air for combustion, ventilation, and dilution of flue gases.

WARNING

Do not install boiler where gasoline or other flammable vapors or liquids, or sources of hydrocarbons (i.e. bleaches, cleaners, chemicals, sprays, paint removers, fabric softeners, etc.) are used or stored.

NOTICE

Mis-sizing of the boiler with regard to the heating system load will result in excessive boiler cycling and accelerated component failure. Crown DOES NOT warrant failures caused by mis-sized boiler applications. DO NOT oversize the boiler to the system. Modular/multiple boilers greatly reduce the likelihood of boiler oversizing.

II. Boiler Assembly

A. Remove Crate

1. Remove all fasteners at crate skid.
2. Lift outside container and remove with all other inside protective spacers and bracing.

B. Remove boiler from skid. See Figure 2. Exercise care to avoid dropping boiler.

1. Place boiler in approximate location. Refer to Section I: Pre-Installation. Remove base hold down bolts.
2. Using pry bar under rear corner of Base End Panel, raise boiler and install 1½” wood blocks under rear corners. Install ¾” pipe roller between Base and skid.
3. Remove 1½” wood blocks. Place 3” pipe roller on floor behind skid.
4. Roll boiler off skid. Move skid out of way.
5. Roll boiler until 3” roller is located as shown. Use pry bar to install wood blocks under front corners of base. Remove 3” roller.

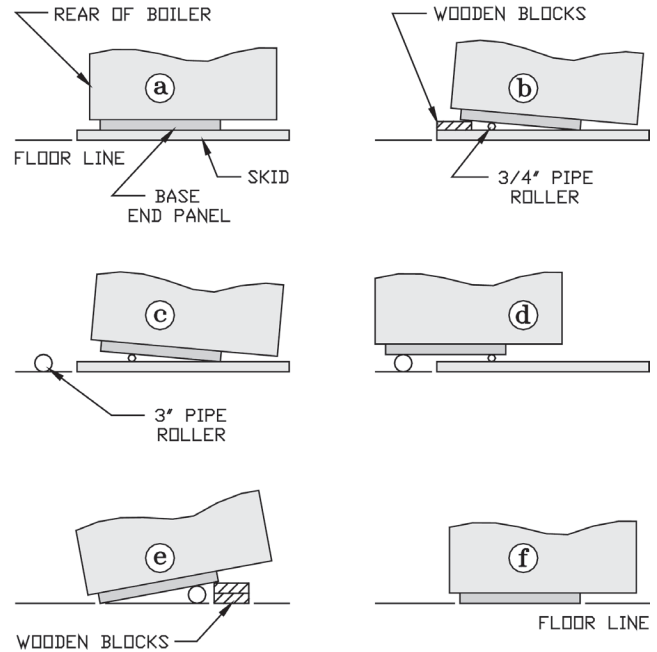

Figure 2: Skid Removal

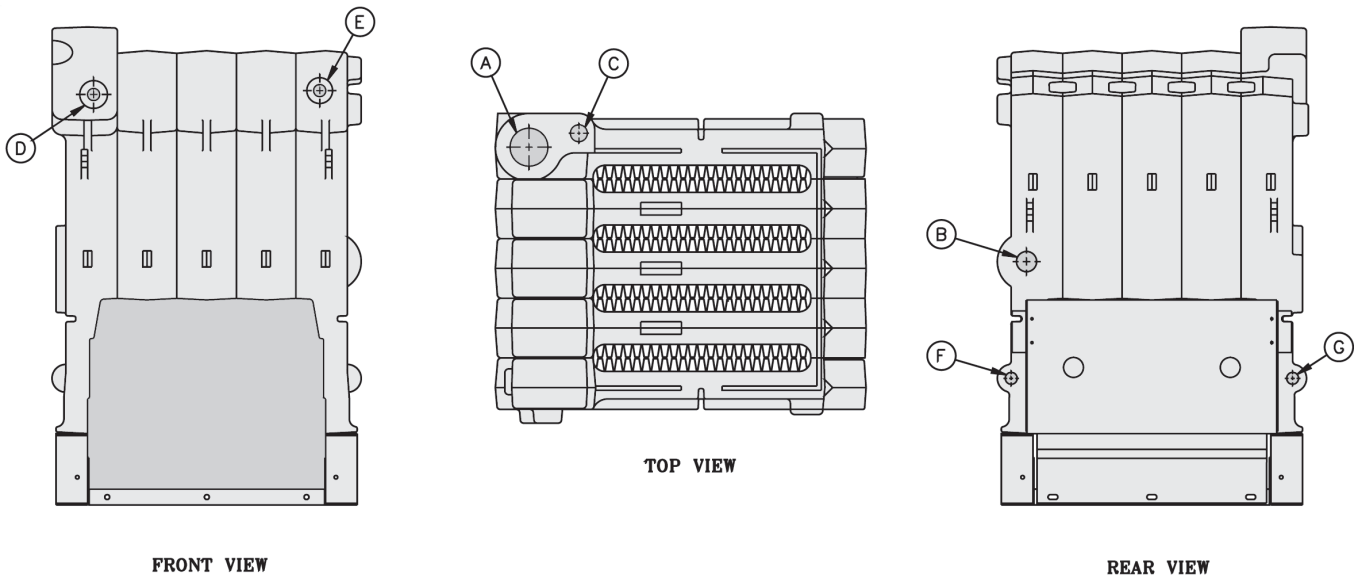

Figure 3: Tapping Locations

Table 3: Purpose of Tappings

Tapping	Size	Purpose
A	2"	Supply
B	2"	Return
C	¾"	Relief Valve
D	¾"	Limit
E	¾"	Auxiliary Limit
F	¾"	Washout
G	¾"	Drain

- Lift boiler with pry bar. Remove wood blocks.
Lower boiler.

D. Test Section Assembly for leaks before connecting to system and installing controls, trim and jacket. Refer to Figure 3 and Table 3.

- Plug Tappings C & E ($\frac{3}{4}$ " NPT) and Return Tapping B (2 NPT).
- Insert $\frac{3}{4}$ " NPT x $\frac{1}{4}$ " NPT bushing in Tapping D. Install pressure gauge capable of indicating 50 psi.
- Insert 2" NPT x $\frac{3}{4}$ " NPT bushing in Supply Tapping A. Install purge valve with a hose that runs to a drain.
- Connect fill valve and piping to Drain Tapping G.

WARNING

Do not use air to leak test boiler.

- Fill boiler completely with water by venting air through purge valve. Close purge valve and apply water pressure of at least 10 psi but less than 50 psi

gauge pressure.

- Examine boiler for leaks or damage due to shipment or handling.
- Remove plugs from Return Tapping B, Tapping C, and Tapping E (if second limit or operating control is used). Also remove fill valve and piping, purge valve and piping, and pressure gauge.

E. Install special base if installation is on combustible flooring. See Figure 4. Floor shield adds $4\frac{3}{4}$ " to boiler height.

- Place special base on combustible floor with surface marked "FRONT" in upward position.
- Locate special base with spacing to combustible materials as shown in Figure 4.
- Place boiler on special base. Boiler must rest inside locating brackets. Boiler jacket panels will overhang special base.
- Do not enclose boiler (including special base) on all four sides. Models 16H-340 may be enclosed on three sides (alcove) while maintaining clearances shown in Figure 4.

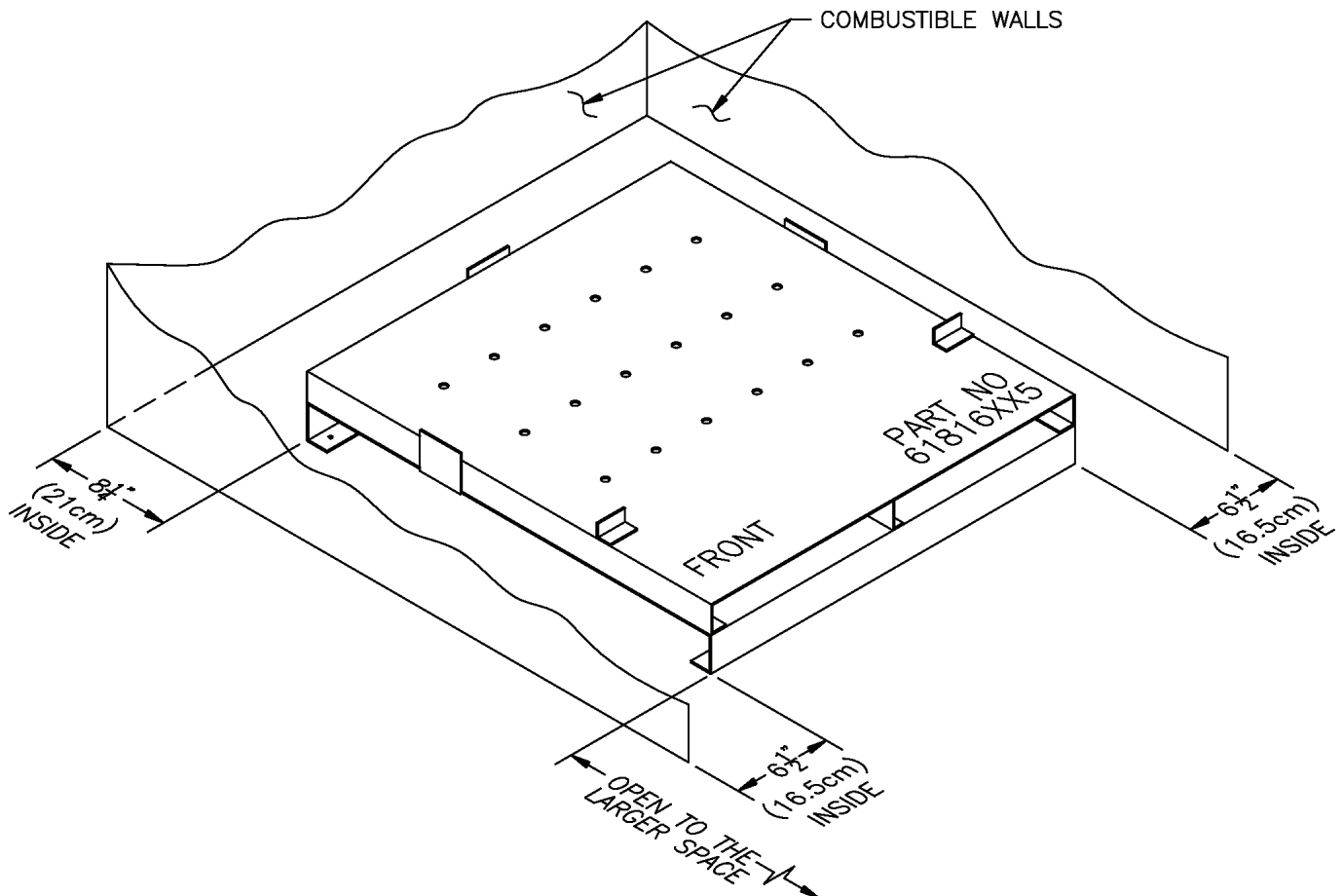

Figure 4: Installation of Special Base for Combustible Flooring

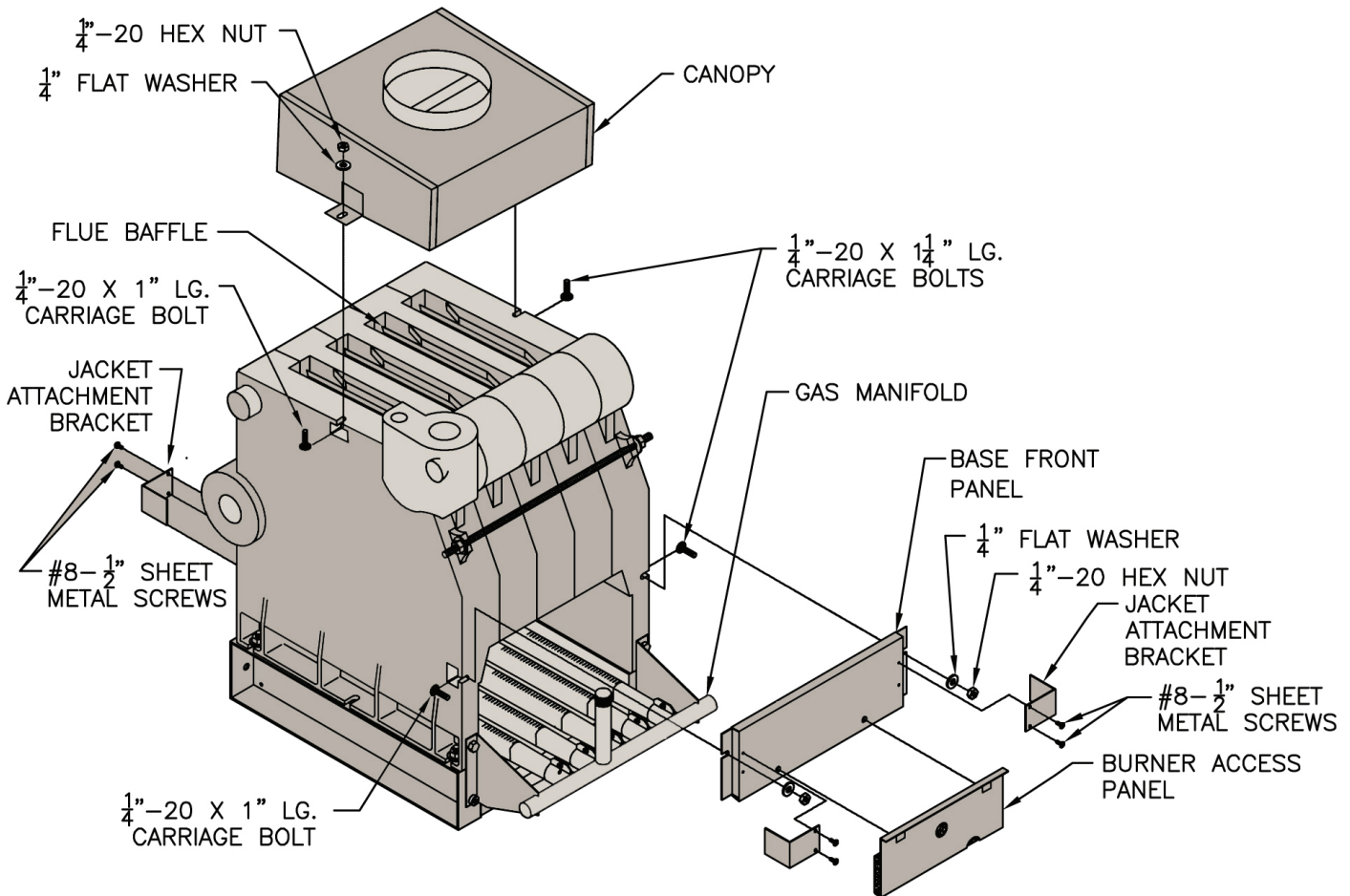

Figure 5: General Assembly (Knockdown Boilers)

F. Move boiler to permanent location by sliding or walking. Do not drop.

G. Confirm that one (1) Flue Baffle is properly positioned in each Boiler Flueway. Tabs at the top of each Flue Baffle should be resting on top row of Flue Pins on each adjoining section.

H. Install Canopy on section assembly. See Figure 5. Canopy and hardware are located in Combination Boiler Parts and Control Carton.

1. Position Canopy on top of Section Assembly. Locate between end sections and sealing ledge on front and back of each section.
2. Fasten each end with 1/4" - 20 x 1" carriage bolts, washers and nuts.
3. Seal between Canopy and Section Assembly with furnace cement.

I. Inspect joints between sections. They were factory sealed. If any openings resulted during shipment or handling, reseal with furnace cement. Confirm tie rods are only hand tight to allow for thermal expansion.

J. Install Base Front Panel. See Figure 5. Panel and hardware located in Combination Boiler Parts and Control Carton.

1. Attach Base Front Panel to Section Assembly using

1/4" - 20 x 1 1/4" carriage bolts, washers and nuts.

2. Seal between top of Base Front Panel and Section Assembly with furnace cement (shipped in Combination Boiler Parts and Control Carton).
3. Seal between top of Base Rear Panel and Section Assembly with furnace cement.

K. Install Pilot/Main Burner Assembly. See Figure 7. Assembly is located in Combination Boiler Parts and Control Carton. Verify assembly is properly located on support bracket in Base Rear Panel, seated on Main Burner Orifice, and secured with hitch pin clip.

L. Adjust Burner Air Shutters on all Burners. See Figure 7. Distance between front edge of Burner Air Shutter and burner mounting ring should be approximately 11/16". To adjust this distance, loosen screw at top of air shutter and slide into correct position. Then tighten screw. (Replace Burner Access Panel(s) and Front Door on Packaged Boilers.)

M. Attach Flame Roll-out Switch to Burner Access Panel. See Figure 6. Flame Roll-out Switch and hardware are located in Combination Boiler Parts and Control Carton. Flame Roll-out Switch is a single use device - do not test with heat - switch cannot be reset.

1. Cut insulation from semicircular notch at right

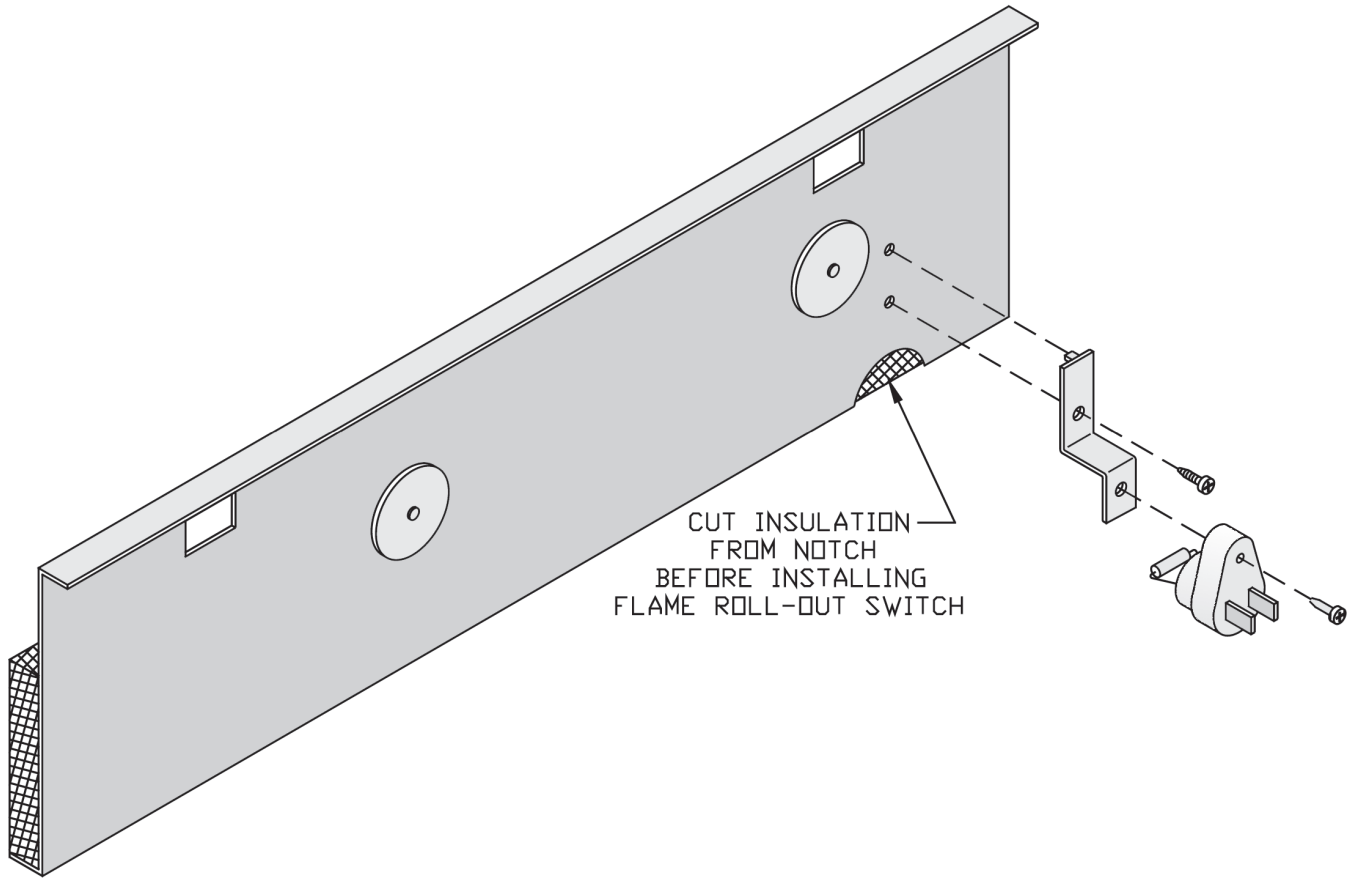

Figure 6: Flame Roll-out Switch Installation

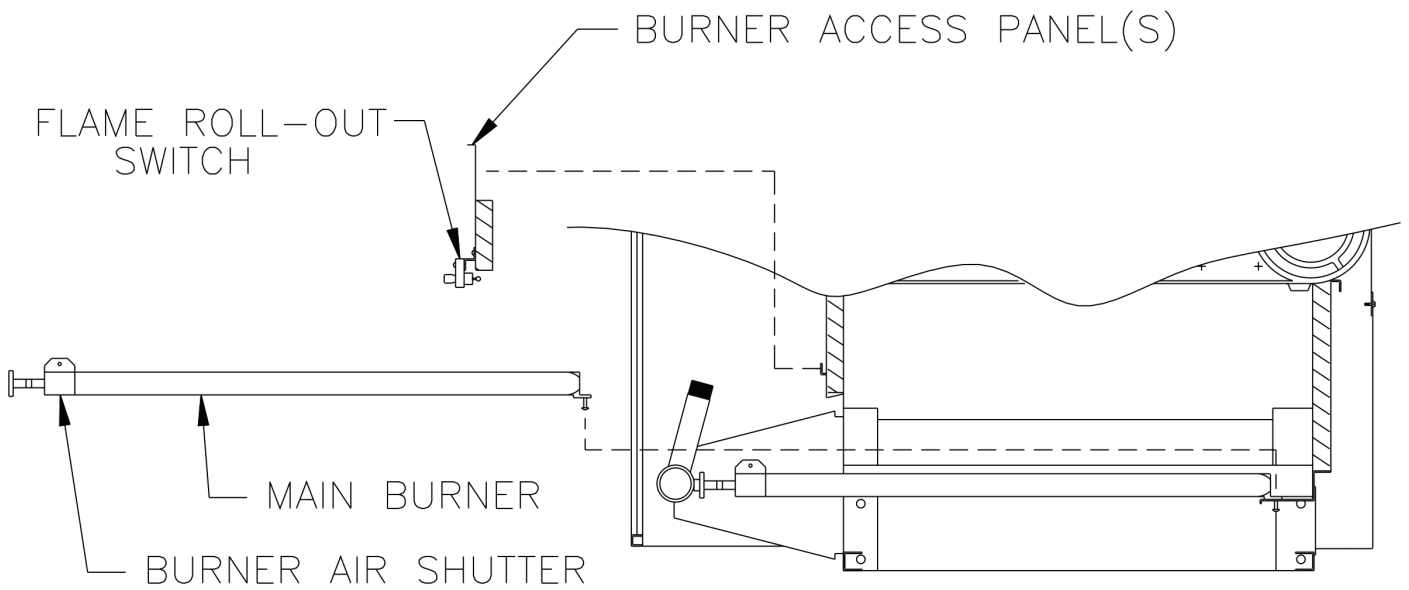

Figure 7: Burner/Burner Access Panel Installation

end of the burner access panel. Models 16H-410-16H-505 have two (2) burner access panels.

Remove insulation from notch of right side burner access panel only.

2. Attach Flame Roll-out Switch Mounting Bracket to burner access panel with (1) #8 x 1/2" lg. sheet metal screw.
3. Attach Flame Roll-out Switch to mounting bracket with (1) #8 x 3/4" lg. sheet metal screw.

N. Install Burner Access Panel(s). Locate Burner Access Panel(s) in Combination Boiler Parts and Control Carton. Engage Burner Access Panel holes with projections on Base Front Panel. See Figure 5.

O. Install Immersion Well(s).

1. Remove Immersion Well(s) from Combination Boiler Parts and Control Carton..
2. Insert Immersion Well in Tapping D. See Figure 3.
3. If second limit or operating control is used, insert immersion well in Tapping E. If vertical gas piping is to be installed inside of boiler jacket, it is recommended that second limit be installed in system piping.

P. Install Jacket. See Figure 8.

1. Locate four (4) Jacket Attachment Brackets in Combination Boiler Parts and Control Carton. Attach to Front Base Panel and Rear Base Panels with #8 sheet metal screws. See Figure 5.
2. Hang Left Side Panel and Right Side Panel onto Jacket Attachment Brackets.
3. Attach Lower Rear Panel to Left and Right Side Panels. Do not tighten sheet metal screws.
4. Attach Upper Rear Panel to Lower Rear Panel. Do not install three (3) upper screws.
5. Remove Rating Label from envelope marked "RATING LABEL ENCLOSED". Remove Combustible Clearance Label from Combination Boiler Parts and Controls Carton. Attach to Vestibule Panel in locations shown.
6. Attach Vestibule Panel to Left Side and Right Side Panels.
7. Attach Lower Front Tie Bar to Left Side and Right Side Panels.
8. Engage Upper Front Panel in slots on Left Side and Right Side Panels. Place Top Panel in position.

Attach Top Panel to Left Side, Right Side and Upper Rear Panels.

9. Tighten all jacket screws.
10. Affix Lighting/Operating Instructions Label and Wiring Diagram Label to inside of Front Removable Door. Labels are located in Combination Boiler Parts and Control Carton.

Q. Install Junction Box. See Figure 8. Attach junction box to inside of Left Side Panel with 1/4" - 20 x 1/4" lg. machine screw (located in Combination Boiler Parts and Control Carton).

R. Install Limit Control. Locate limit in Combination Boiler Parts and Control Carton. Insert limit probe into left immersion well as far as possible. Tighten set screw.

S. Install Auxiliary Limit or operating control (if used). Insert control probe into right immersion well as far as possible. Tighten set screw.

T. Install Gas Control Assembly. Refer to Section III, Gas Control System Assembly.

U. EP-CSD-1 System: See Figure 9.

1. Install pre-wired EP Control Cabinet Assembly to right front corner of jacket top panel.
2. Install Honeywell RM7890 Control (located in RM7890 Control Carton).
3. Remove RM7890's Dust Cover. With a pair of side cutters, carefully snip both wire leads to the brown resistor labelled "JR2" and discard it. Replace Dust Cover.
4. Install Honeywell R7847 Flame Amplifier.
5. Install heat shield.

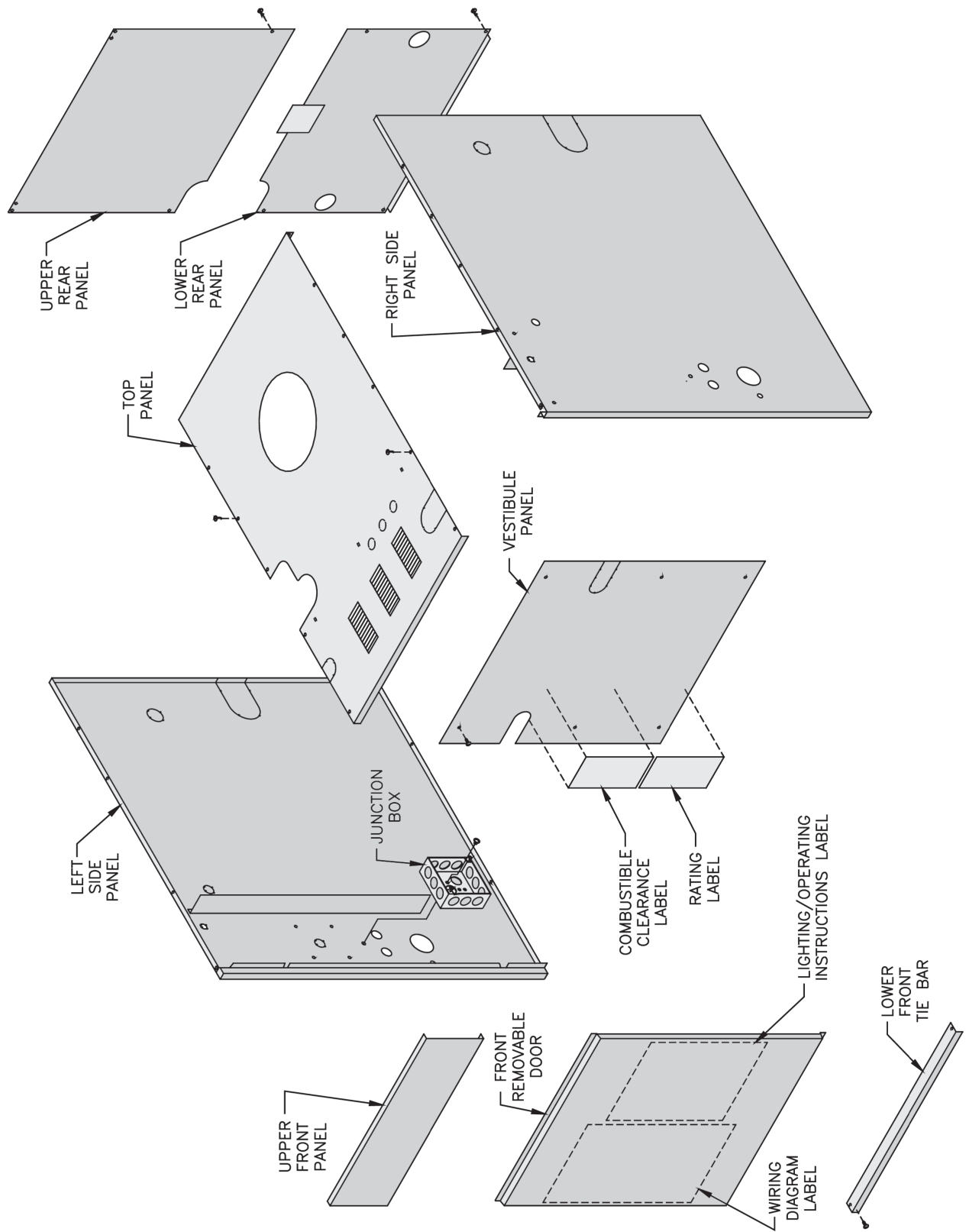

Figure 8: Jacket Assembly

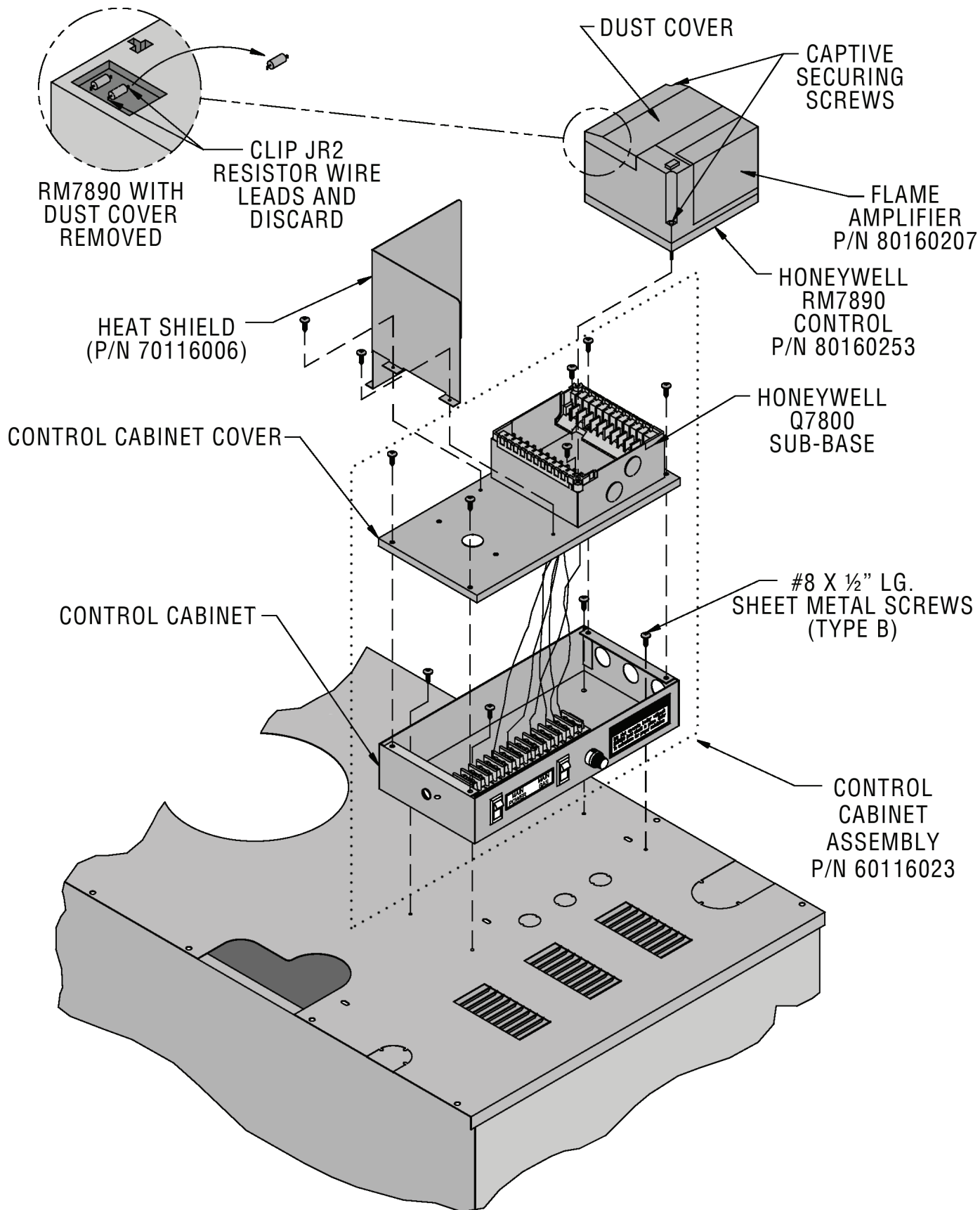

Figure 9: EP-CSD-1 Control Installation

III. Gas Control System Assembly (Knockdown Boilers)

A. EI (Intermittent Ignition)

Install Gas Control System. All components are located in Combination Boiler Parts and Control Carton.

1. Install Gas Control Assembly on Manifold. See Figure 11. Use thread (joint) compound (pipe dope) resistant to action of liquefied petroleum gas.
2. Install pilot burner piping and controls.
 - a. Honeywell EI
 - i. USA - See Figure 12.
3. Install Ignition Module.
 - a. Attach Ignition Control Mounting Bracket to Jacket Vestibule Panel using two (2) #8 x 1/2" sheet metal screws.
 - b. Attach Honeywell Ignition Module to Mounting Bracket using two (2) #8 x 1/2" sheet metal screws.
 - c. Connect pilot ground wire and ignitor/sensor lead(s) to ignition module. Refer to "Section VII: Electrical" for connection details.
4. Mount Transformer (continuous circulation) or Control Center (intermittent circulation) to Junction Box. See Figure 8.
 - a. Canada only - loop 4" nylon cable tie between junction box and transformer/control center.
 - b. Attach transformer/control center to junction box.

B. EP-CSD-1 Control System

Install Gas Control System. All components are located in Combination Boiler Parts and Control Carton.

1. Install Gas Control Assembly on Manifold. See Figure 15.
2. Install pilot burner piping and controls. See Figure 15.
3. Install Ignition Transformer.
 - a. Attach Ignition Transformer to Jacket Vestibule Panel using four (4) #8 x 1/2" lg. sheet metal screws.
 - b. Connect Ignition Lead from Pilot to Ignition Transformer.
4. Mount Control Center (intermittent circulation) to Junction Box.
 - a. Attach transformer/control center to junction box.

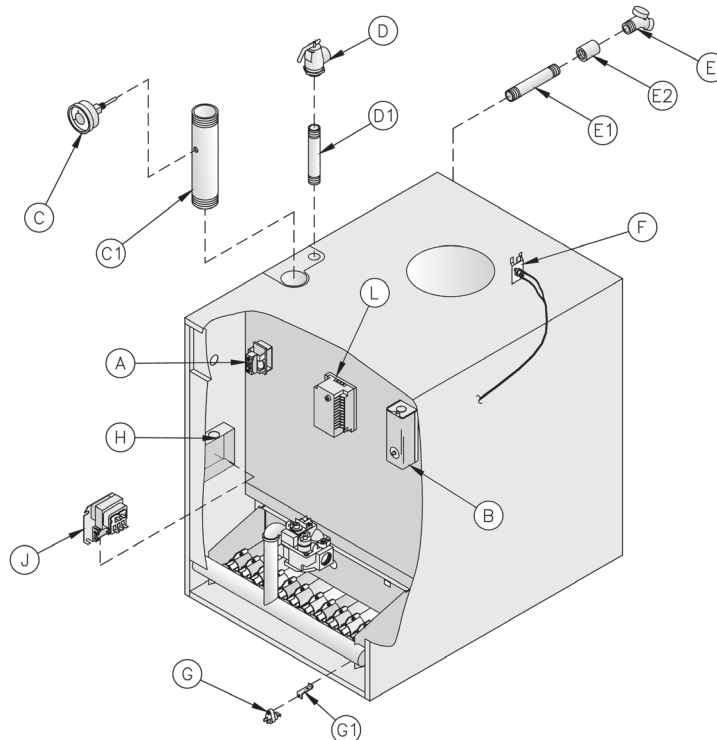

Figure 10: Trim & Miscellaneous Control Locations (See #7 in Repair Parts List for Component Identification)

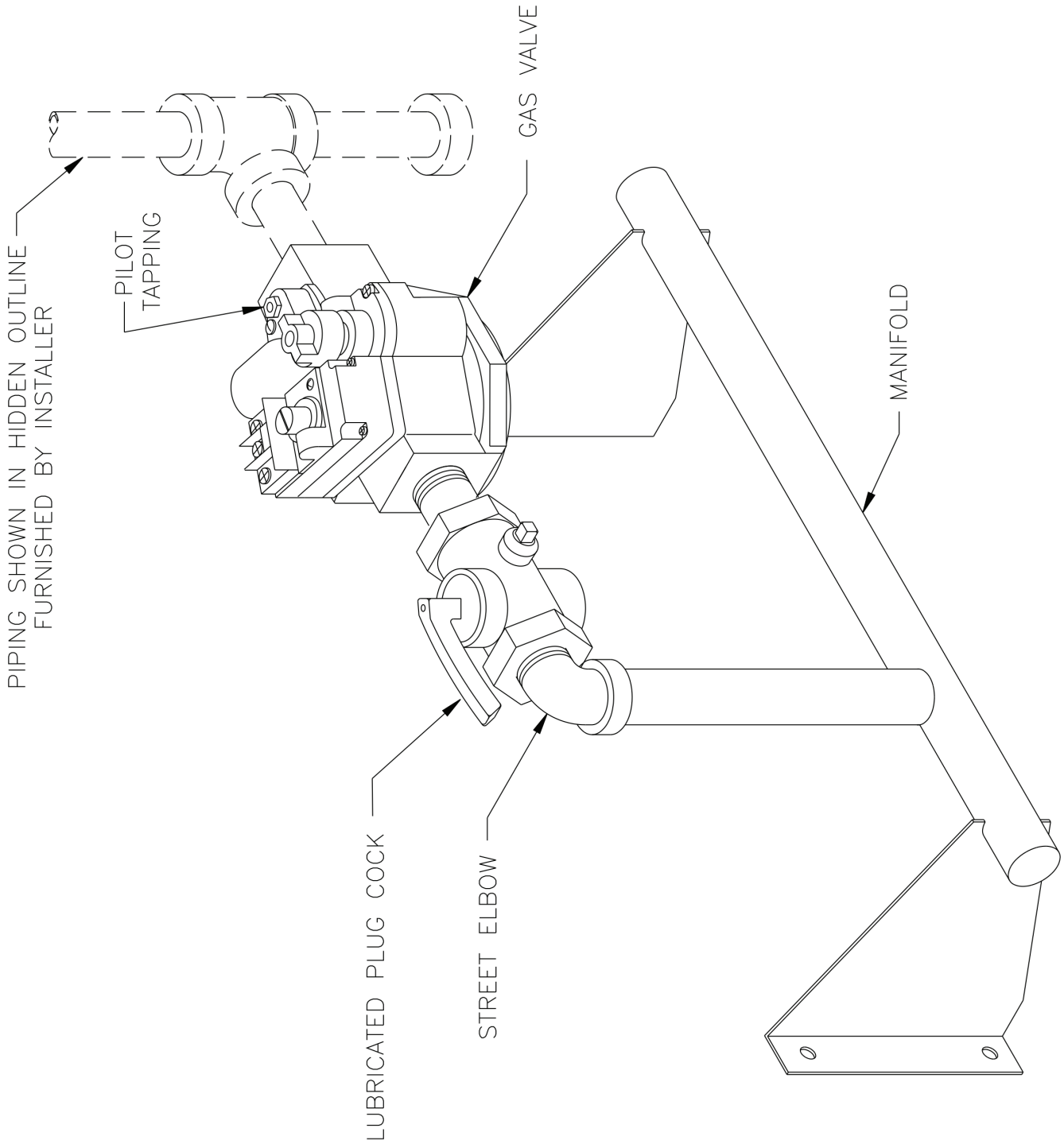

Figure 11: Main Gas Piping, Intermittent Ignition (EI)

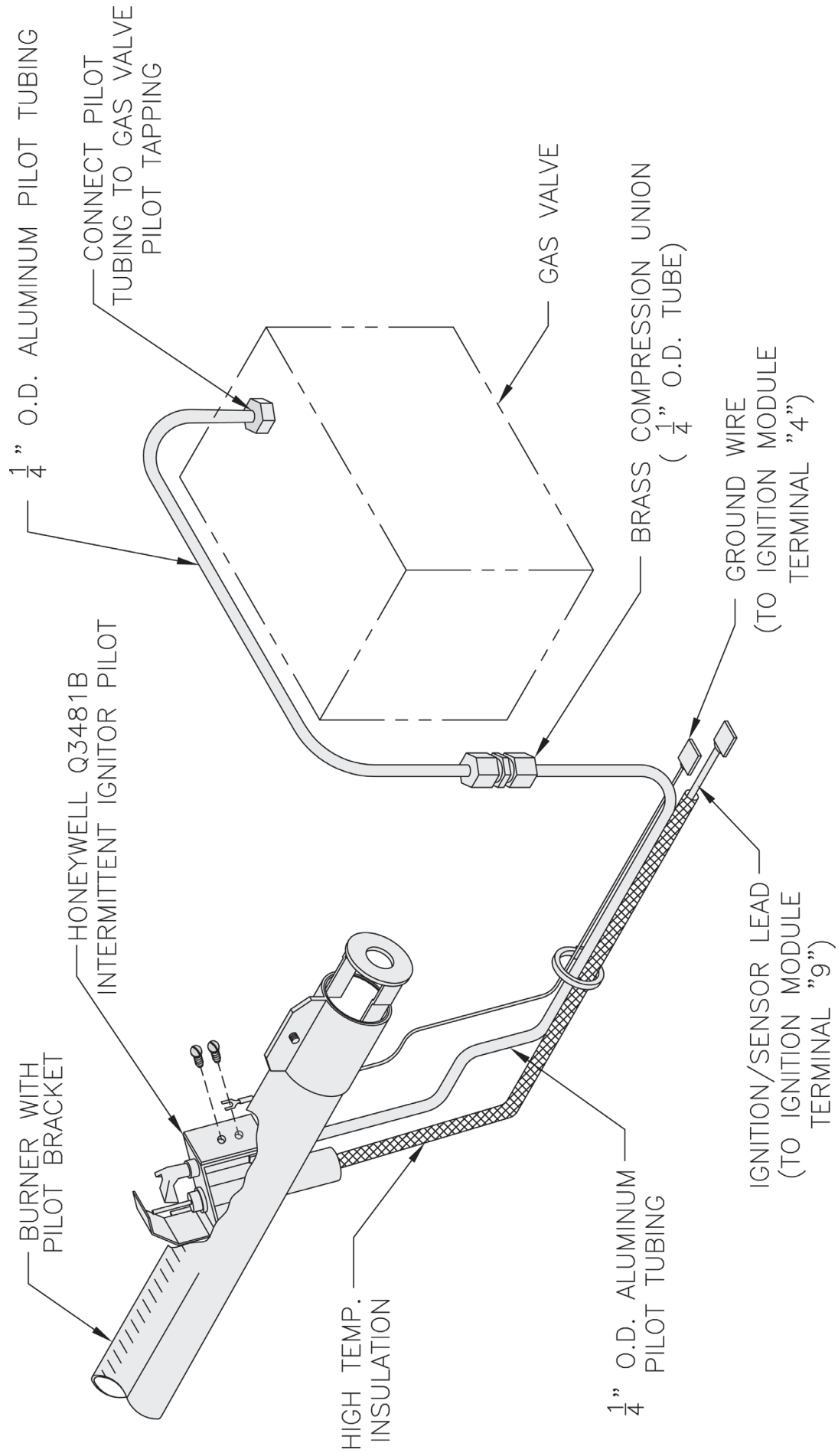
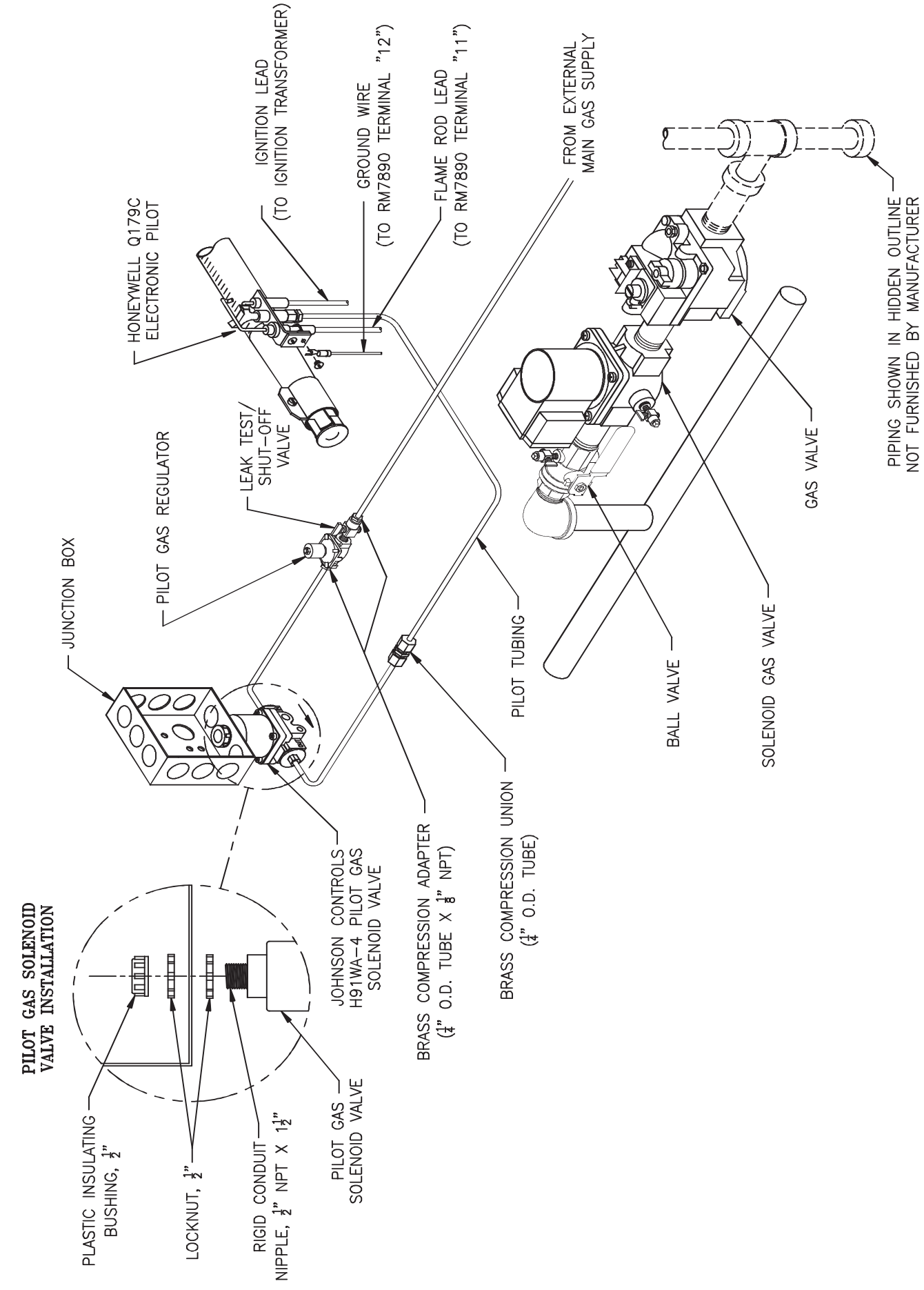

Figure 12: Schematic Pilot Piping (Honeywell EI), USA



PIPING SHOWN IN HIDDEN OUTLINE NOT FURNISHED BY MANUFACTURER

Figure 15: Schematic Gas Piping, EP-CSD-1 Control System, 16H-410 - 16H-505

IV. Water Trim and Piping

WARNING

Failure to properly pipe boiler may result in improper operation and damage to boiler or structure.

Oxygen contamination of boiler water will cause corrosion of iron and steel boiler components, and can lead to boiler failure. Crown's Warranty does not cover problems caused by oxygen contamination of boiler water or scale (lime) build-up caused by frequent addition of water.

A. Design and install boiler and system piping to prevent oxygen contamination of boiler water and frequent water additions.

1. There are many possible causes of oxygen contamination such as:
 - a. Addition of excessive make-up water as a result of system leaks.
 - b. Absorption through open tanks and fittings.
 - c. Oxygen permeable materials in the distribution system.
2. In order to insure long product life, oxygen sources must be eliminated. This can be accomplished by taking the following measures:
 - a. Repairing system leaks to eliminate the need for addition of make-up water.
 - b. Eliminating open tanks from the system.
 - c. Eliminating and/or repairing fittings which allow oxygen absorption.
 - d. Use of non-permeable materials in the distribution system.
 - e. Isolating the boiler from the system water by installing a heat exchanger.
 - f. Use properly designed and operating air elimination devices in water piping.

B. Design boiler piping and flow rate to obtain proper temperature rise through the boiler. (See Table 4)

Table 4: Flow Rate, Temperature Rise, and Pressure Drop

Boiler Model	Flow Rate (GPM)	Temp. Rise Thru Boiler	Min. Boiler Piping NPT	Boiler Pressure Drop
16H-340	28	20° F	2"	3'
	19	30° F	1½"	2'
	14	40° F	1¼"	1'
16H-410	34	20° F	2"	3'
	22	30° F	1½"	2'
	17	40° F	1½"	1'
16H-460	38	20° F	2"	3'
	25	30° F	2"	2'
	19	40° F	1½"	1'
16H-505	42	20° F	2"	3'
	28	30° F	2"	2'
	21	40° F	1½"	1'

WARNING

Pressure relief valve discharge piping must be piped such that the potential of severe burns is eliminated. DO NOT pipe in any area where freezing could occur. DO NOT install any shut off valves, plugs or caps. Consult Local Codes for proper discharge piping arrangement.

C. Install Safety Relief Valve. See Figure 16.

Components are located in Water Trim Carton. Safety Relief Valve must be installed with spindle in vertical position.

1. Install ¾" NPT x 3½" lg. nipple in tapping "C". See Figure 3.
2. Install safety relief valve on ¾" NPT nipple.

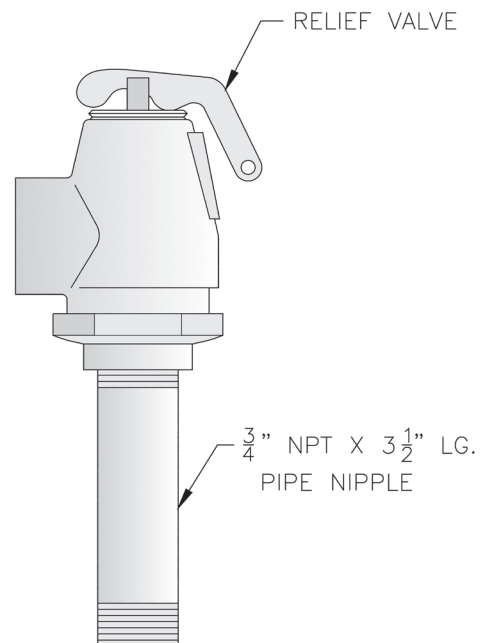

Figure 16: Safety Relief Valve Installation

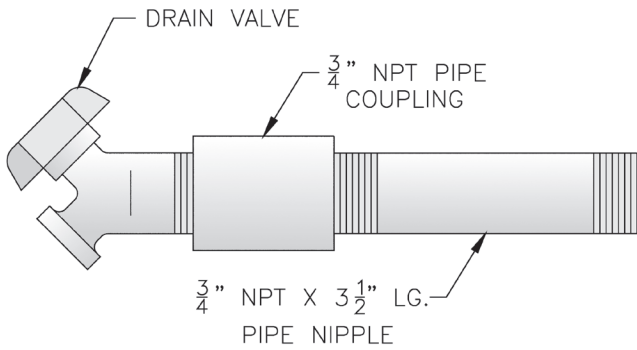

Figure 17: Drain Piping Installation

D. Install Drain Valve in rear of Left End Section, Tapping “G”. See Figure 17. Components are located in Water Trim Carton.

E. Install Temperature-Pressure Gauge. Components are located in Water Trim Carton.

1. Standard Temperature - Pressure Gauge Piping. See Figure 18.

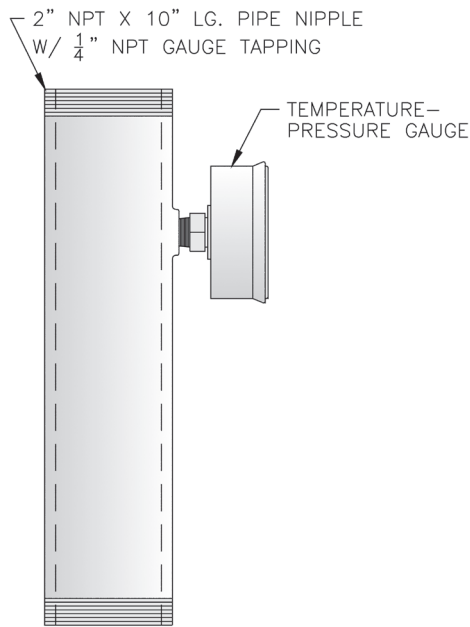

Figure 18: Temperature-Pressure Gauge Installation

1. Install 2” NPT x 10” lg. nipple with gauge tapping into Supply Tapping “A”. See Figure 3. Gauge tapping should face forward.
 2. Insert Temperature-Pressure Gauge. Tighten by applying pressure to square shank on back of gauge. **DO NOT APPLY PRESSURE ON GAUGE CASE** since this may ruin gauge calibration.
2. Alternate Temperature-Pressure Gauge Piping. See Figure 19.
 1. Install 2 NPT x 10” Nipple into Supply Tapping “A”. See Figure 3.

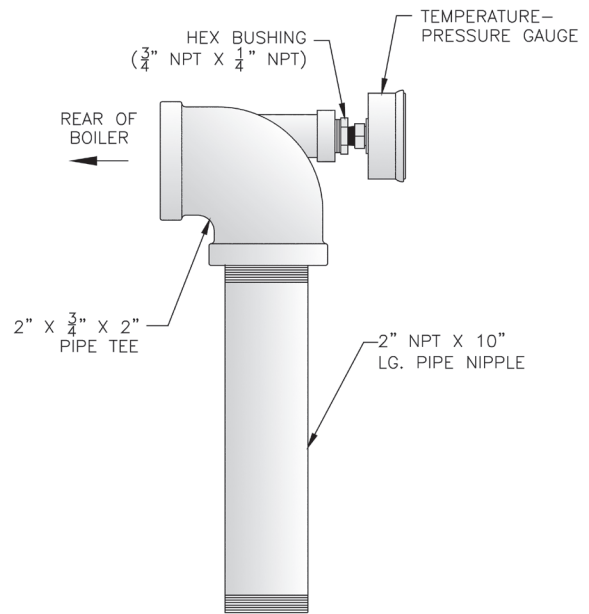

Figure 19: Alternate Temperature-Pressure Gauge Installation

2. Install 2 NPT x 3/4 NPT x 2 NPT Tee (provided) or 2 NPT x 2 NPT x 3/4 NPT Tee (installer furnished). 3/4 NPT leg should face forward.
3. Install 3/4 NPT x 1/4 NPT Bushing.
4. Insert Temperature-Pressure Gauge. Tighten by applying pressure to square shank on back of gauge. **DO NOT APPLY PRESSURE ON GAUGE CASE** since this may ruin gauge calibration.

F. Connect system supply and return piping to boiler. See Figure 21. Also, consult I=B=R Installation and Piping Guide No. 250. Maintain minimum 1/2 inch clearance from hot water piping to combustible materials.

1. If boiler is used in connection with refrigeration systems, boiler must be installed with chilled medium piped in parallel with heating boiler using appropriate valves to prevent chilled medium from

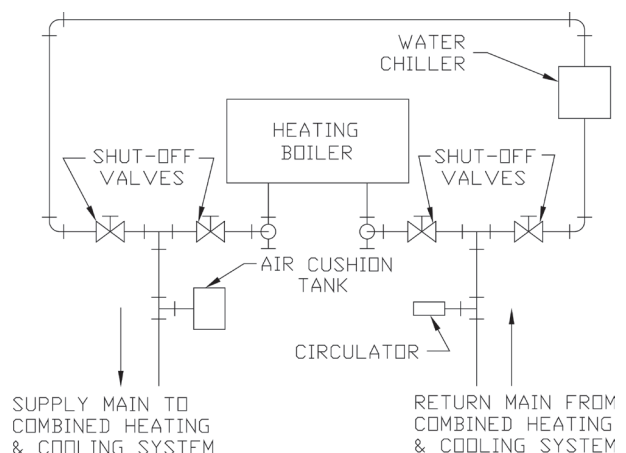

Figure 20: Recommended Piping for Combination Heating & Cooling (Refrigeration) System

entering boiler. See Figure 20. Also, consult I=B=R Installation and Piping Guide No. 250.

2. If boiler is connected to heating coils located in air handling units where they may be exposed to refrigerated air, boiler piping must be equipped with flow control valves to prevent gravity circulation of boiler water during cooling system operation.
3. The piping diagrams shown (Figure 21, Detail "A" and Detail "B") are recommended for optimum operation and long term reliability.

Crown recommends maintaining temperature differential (drop) across the system at 40°F or less, and return water temperature at minimum of 135°F. Continued boiler operation for prolonged periods of time under conditions when temperature differential across the system exceeds 40°F and/or return water temperature stays below 135°F, may result in premature boiler failure due to flue gas condensation and/or thermal shock.

Pump flow rates and minimum boiler supply and return pipe sizes are shown in Table 4.

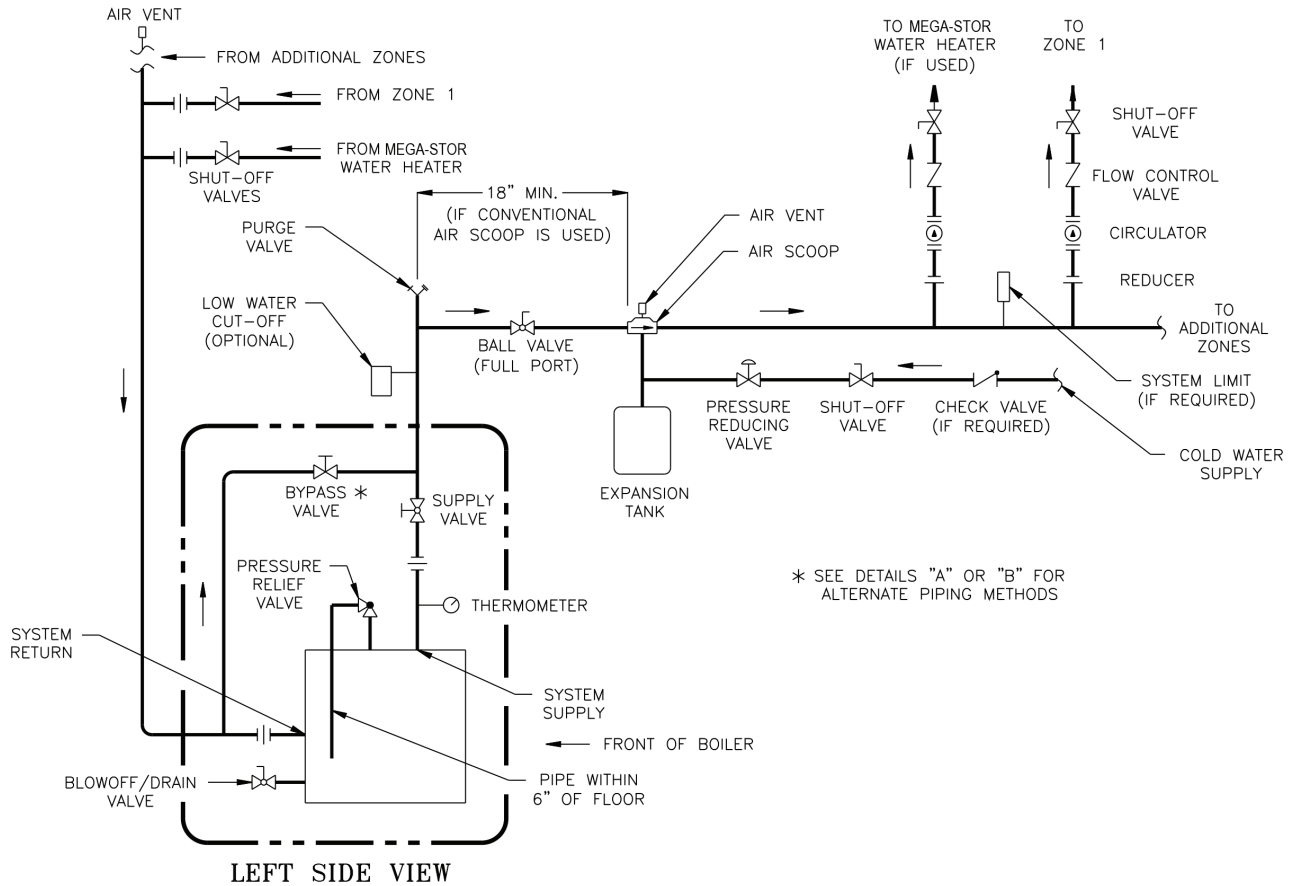
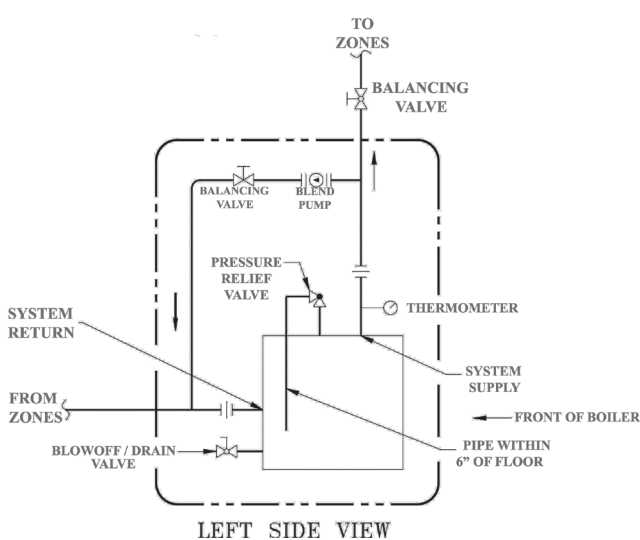
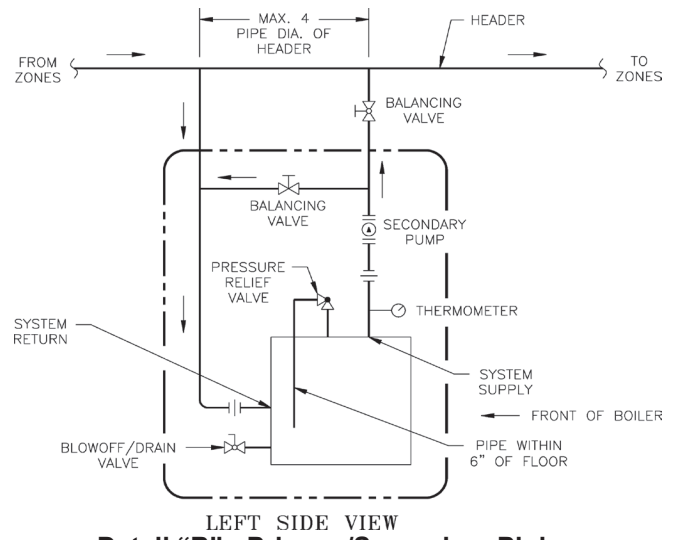

Figure 21: Recommended Boiler Piping for Circulator Zoned Heating Systems



Detail "A": Blend Pump Piping



Detail "B": Primary/Secondary Piping with By-Pass

- a. A boiler by-pass is recommended for any installation for improved system temperature balance, while serving to protect the boiler from sustained condensing operation. The by-pass also provides some measure of low return water temperature protection by reducing flow through the boiler. See Figure 21.
 - b. A blend pump is recommended to divert hot supply water into the return when system return temperatures can periodically dip below 135°F or when delta T's rise beyond 40°F because of control schemes that shut off zone pumps for extended periods. See Figure 21, Detail "A".
 - c. Primary/secondary piping with a by-pass is recommended to provide two points of mixing when dual temperature systems are used (i.e. baseboard and radiant heat, outdoor reset and domestic hot water production, systems incorporating night setback or multiple zone pumps on clock schedules). See Figure 21, Detail "B".
 - d. If system three-way valves are used for temperature modulation, or if the system will continuously run below 135°F for extended periods (due to low temperature applications like snow melt, heat pump systems or others), primary/secondary boiler piping with a three-way valve and return temperature sensor is recommended.
4. A hot water boiler installed above radiation level must be provided with a low water cutoff device as part of installation.
 5. A start-up strainer is recommended for all installations (new and replacement alike) to prevent system debris and sediment from ending up in the boilers where it will inhibit heat transfer and may eventually cause a cast iron section to crack from overheating.
- G. Water Heater** (if used). Refer to Mega-Stor Installation and Operating Instructions for additional information. Install in same manner as space heating zone.

WARNING

Crown recommends maintaining temperature differential (drop) across the system at 40°F or less and return water temperature at minimum of 135°F.

Continued boiler operation for prolonged periods of time under conditions when temperature differential across the system exceeds 40°F and/or return water temperature stays below 135°F, may result in premature boiler failure due to flue gas condensation and/or thermal shock.

If the above conditions exist, to protect a boiler from sustained flue gas condensation and/or thermal shock, the above-recommended temperatures may be maintained by employing common industry-accepted mixing methods to provide boiler protection.

Some common methods are boiler by-pass piping, blend pumps, primary secondary piping with a by-pass, mixing valves and/or variable speed injection pumps.

Recommended Water Quality Requirements

pH: 8.3 - 10.5

TDS: < 3500 ppm

Total alkalinity ppm as CaCO₃: < 1200

Total copper ppm: < .05

Oily matter ppm: < -1

Total harness ppm: < -3

Chlorides: < 50 ppm

V. Gas Piping

WARNING

Failure to properly pipe gas supply to boiler may result in improper operation and damage to the boiler or structure. Always assure gas piping is absolutely leak free and of the proper size and type for the connected load.

An additional gas pressure regulator may be needed. Consult gas supplier.

A. Size gas Piping. Design system to provide adequate gas supply to boiler. Consider these factors:

1. Allowable pressure drop from point of delivery to boiler. Maximum allowable system pressure is $\frac{1}{2}$ psig. Actual point of delivery pressure may be less; contact gas supplier for additional information. Minimum allowable gas valve inlet pressure is indicated on rating label.
2. Maximum gas demand. Table 5 lists boiler input rate. Also consider existing and expected future gas utilization equipment (i.e. water heater, cooking equipment).
3. Length of piping and number of fittings. Refer to Table 6 for maximum capacity of Schedule 40 pipe. Table 7 lists equivalent length for standard fittings.

Table 5: Rated Input

Boiler Model	Rated Capacity (cubic feet per hour)		Gas Connection Size
	Natural	LP / Propane	
16H-340	340	136.0	1
16H-410	410	164.0	1
16H-460	460	184.0	1
16H-505	505	202.0	1

4. Specific gravity of gas. Gas piping systems for gas with a specific gravity of 0.70 or less can be sized directly from Table 6, unless authority having jurisdiction specifies a gravity factor be applied. For specific gravity greater than 0.70, apply gravity factor from Table 8. If exact specific gravity is not shown choose next higher value.

For materials or conditions other than those listed above, refer to the *National Fuel Gas Code*, NFPA 54/ANSI Z223.1, or size system using standard engineering methods acceptable to authority having jurisdiction.

WARNING

Failure to use proper thread compounds on all gas connectors may result in leaks of flammable gas.

WARNING

Gas supply to boiler and system must be absolutely shut off prior to installing or servicing boiler gas piping.

B. Connect boiler gas valve to gas supply system.

1. Use methods and materials in accordance with local plumbing codes and requirements of gas supplier. In absence of such requirements, follow the *National Fuel Gas Code*, NFPA 54/ANSI Z223.1
2. Use thread (joint) compound (pipe dope) resistant to action of liquefied petroleum gas.
3. Install sediment trap, ground-joint union and manual shut-off valve upstream of boiler gas valve and outside jacket. See Figure 22.
4. All above ground gas piping upstream from manual gas valve must be electrically continuous and bonded to a grounding electrode. Do not use gas piping as a grounding electrode. Refer to the *National Electrical Code*, ANSI/NFPA 70 and/or CSA C22.1 Electrical Code.

NOTICE

Boilers built for installation at altitudes greater than 2,000 feet above sea level have been specially orificed to reduce gas input rate 4 percent per 1,000 feet above sea level per the National Fuel Gas Code, NFPA 54/ANSI Z223.1, Section 8.1.2 and Appendix F.

Table 6: Maximum Capacity of Schedule 40 Pipe in CFH for Gas Pressures of 0.5 psig or Less

Length (Feet)	0.3 Inch w.c. Pressure Drop				0.5 Inch w.c. Pressure Drop			
	½	¾	1	1¼	½	¾	1	1¼
10	132	278	520	1,050	175	360	680	1,400
20	92	190	350	730	120	250	465	950
30	73	152	285	590	97	200	375	770
40	63	130	245	500	82	170	320	660
50	56	115	215	440	73	151	285	580
60	50	105	195	400	66	138	260	530
70	46	96	180	370	61	125	240	490
80	43	90	170	350	57	118	220	460
90	40	84	160	320	53	110	205	430
100	38	79	150	305	50	103	195	400

Table 7: Equivalent Lengths of Standard Pipe Fittings & Valves

Pipe Size	I.D. (Inches)	Valves (Fully Open)				Threaded Fittings			
		Gate	Globe	Angle	Swing Check	90° Elbow	45° Elbow	90° Tee, Flow Through Run	90° Tee, Flow Through Branch
½"	0.622	0.35	18.6	9.3	4.3	1.6	0.78	1.0	3.1
¾"	0.824	0.44	23.1	11.5	5.3	2.1	0.97	1.4	4.1
1"	1.049	0.56	29.4	14.7	6.8	2.6	1.23	1.8	5.3
1¼"	1.380	0.74	38.6	19.3	8.9	3.5	1.6	2.3	6.9

Table 8: Specific Gravity Correction Factors

Specific Gravity	Correction Factor	Specific Gravity	Correction Factor
0.50	1.10	1.30	1.07
0.55	1.04	1.40	1.04
0.60	1.00	1.50	1.00
0.65	0.96	1.60	0.97
0.70	0.93	1.70	0.94
0.75	0.90	---	---
0.80	0.87	---	---

- C. Pressure Test.** The boiler and its gas connection must be leak tested before placing boiler in operation.
1. Protect boiler gas valve. For all testing over ½ psig, boiler and its individual shut-off valve must be disconnected from gas supply piping. For testing at ½ psig or less, isolate boiler from gas supply piping by closing boiler's individual manual shut-off valve.
 2. Locate leaks using approved combustible gas detector, soap and water, or similar nonflammable solution.

WARNING

Do not use matches, candles, open flames, or other ignition source.

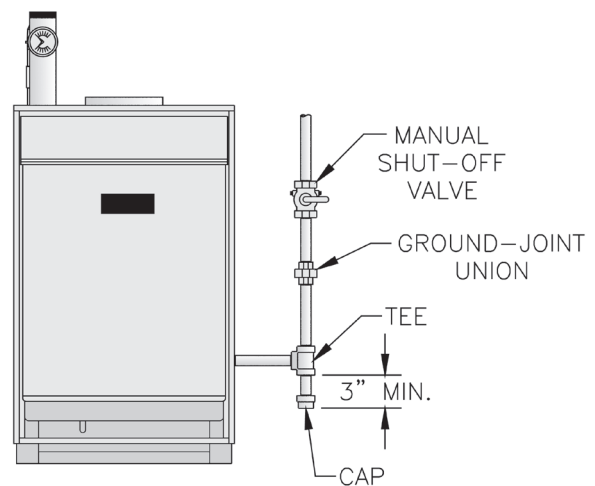

FRONT VIEW

Figure 22: Recommended Gas Piping

VI. Venting

A. Install vent system in accordance with local building codes; or local authority having jurisdiction; or *National Fuel Gas Code*, ANSI Z223.1/NFPA 54, Part 7, Venting of Equipment. Install any of the following for this Series 16H Category I, draft hood equipped appliance:

1. Type B or Type L gas vent. Install in accordance with listing and manufacturer's instructions.
2. Masonry or metal chimney. Build and install in accordance with local building codes; or local authority having jurisdiction; or *Standard for Chimneys, Fireplaces, Vents, and Solid Fuel Burning Appliances*.

Masonry chimney must be lined with approved clay flue lining or listed chimney lining system except as provided in ANSI Z223.1/NFPA 54, Paragraph 7.5.4(a): *Exception: Where permitted by the authority having jurisdiction, existing chimneys shall be permitted to have their use continued when an appliance is replaced by an appliance of similar type, input rating, and efficiency.*

3. Single wall metal vent. Allowed by ANSI Z223.1/NFPA 54 under very restrictive conditions.

B. Inspect chimney and remove any obstructions or restrictions. Clean chimney if previously used for solid or liquid fuel-burning appliances or fireplaces.

DANGER

Inspect existing chimney before installing boiler. Failure to clean or replace perforated pipe or tile lining will cause severe injury or death.

C. Install Draft Hood on canopy outlet. Maintain height from Jacket Top Panel to Draft Hood skirt as shown in Figure 1. **DO NOT ALTER, CUT, OR MODIFY DRAFT HOOD.**

WARNING

Do not alter boiler draft hood or place any obstruction or non-approved damper in the breeching or vent system. Flue gas spillage can occur. Unsafe boiler operation will occur.

D. Install Blocked Vent Switch. The Blocked Vent Switch Assembly consists of a strain relief bushing, power cord, and switch attached to mounting bracket.

1. Uncoil power cord.
2. Position mounting bracket onto lower edge of Draft Hood skirt. Locate center tooth (with #10 sheet

metal screw) on outside and other two teeth inside Draft Hood skirt. See Figure 23.

3. Slide mounting bracket tight against lower edge of Draft Hood skirt. Position #10 sheet metal screw above skirt's stiffening rib.
4. Secure bracket in position by tightening #10 sheet metal screw against outer surface of Draft Hood skirt.
5. Insert excess power cord through Jacket Right Side Panel hole. Remove slack.
6. Position strain relief bushing around power cord. Pinch bushing's two halves together and snap back into hole in Jacket Right Side Panel.
7. Verify power cord, mounting bracket, and Blocked Vent Switch are secure and located as shown in Figure 23.

WARNING

Do not operate boiler without Blocked Vent Switch Properly installed.

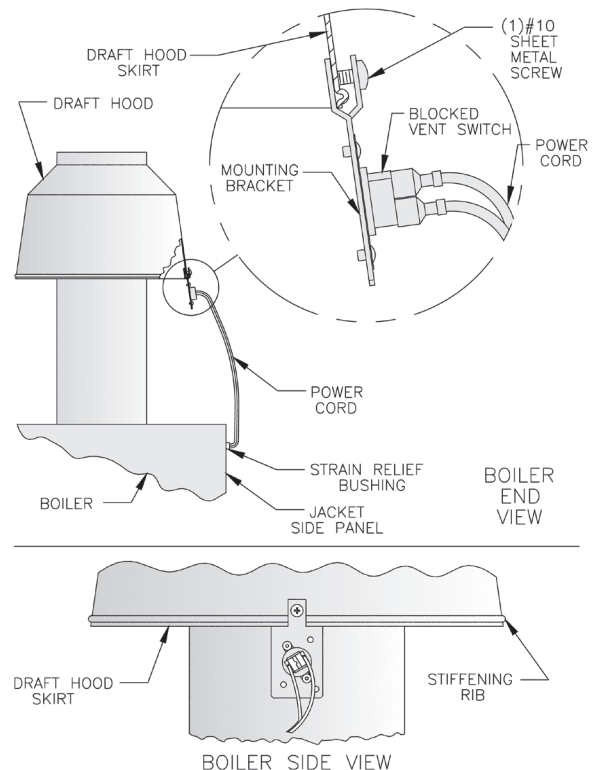

Figure 23: Blocked Vent Switch Installation

E. Boiler Equipped With Vent Damper. See Figure 24.

1. Open Vent Damper Carton and remove Installation Instructions. Read Installation Instructions thoroughly before proceeding.

CAUTION

Do not use one vent damper to control two or more heating appliances.

2. Vent damper must be same size as draft hood outlet. See Figure 1. Unpack vent damper carefully. Forcing vent damper open or closed may damage gear train and void warranty. Vent damper assembly includes pre-wired connection harness with polarized plug.
3. Mount vent damper assembly on draft hood without modification to either (Refer to instructions packed with vent damper for specific instructions). Vent damper position indicator to be visible to users.

WARNING

Provide adequate clearance for servicing - provide 6" minimum clearance between damper and combustible construction.

F. Install Vent Connector from draft hood or vent damper to chimney. See Figure 25.

1. Do not connect into same leg of chimney serving an open fireplace.

2. Where two or more appliances vent into a common vent, the area of the common vent should at least equal the area of the largest vent plus 50 % of the area of the additional vents. Do not connect the vent of this appliance into any portion of mechanical draft system operating under positive pressure.
3. Vent connector should have the greatest possible initial rise above the draft hood consistent with the head room available and the required clearance from adjacent combustible building structure.
4. Install vent connector above bottom of chimney to prevent blockage - inspect chimney for obstructions or restrictions and remove - clean chimney if necessary.
5. Vent connector should slope upward from draft hood to chimney not less than one inch in four feet. No portion of vent connector should run downward or have dips or sags. Vent connector must be securely supported.
6. Use thimble where vent connector enters masonry chimney - keep vent connector flush with inside of flue liner.
7. Do not install Non-listed (AGA, CGA, CSA, ETL, or UL) vent damper or other obstruction in vent pipe.
8. Locate Boiler as close to Chimney as possible consistent with necessary clearances. See Section I: Pre-Installation.

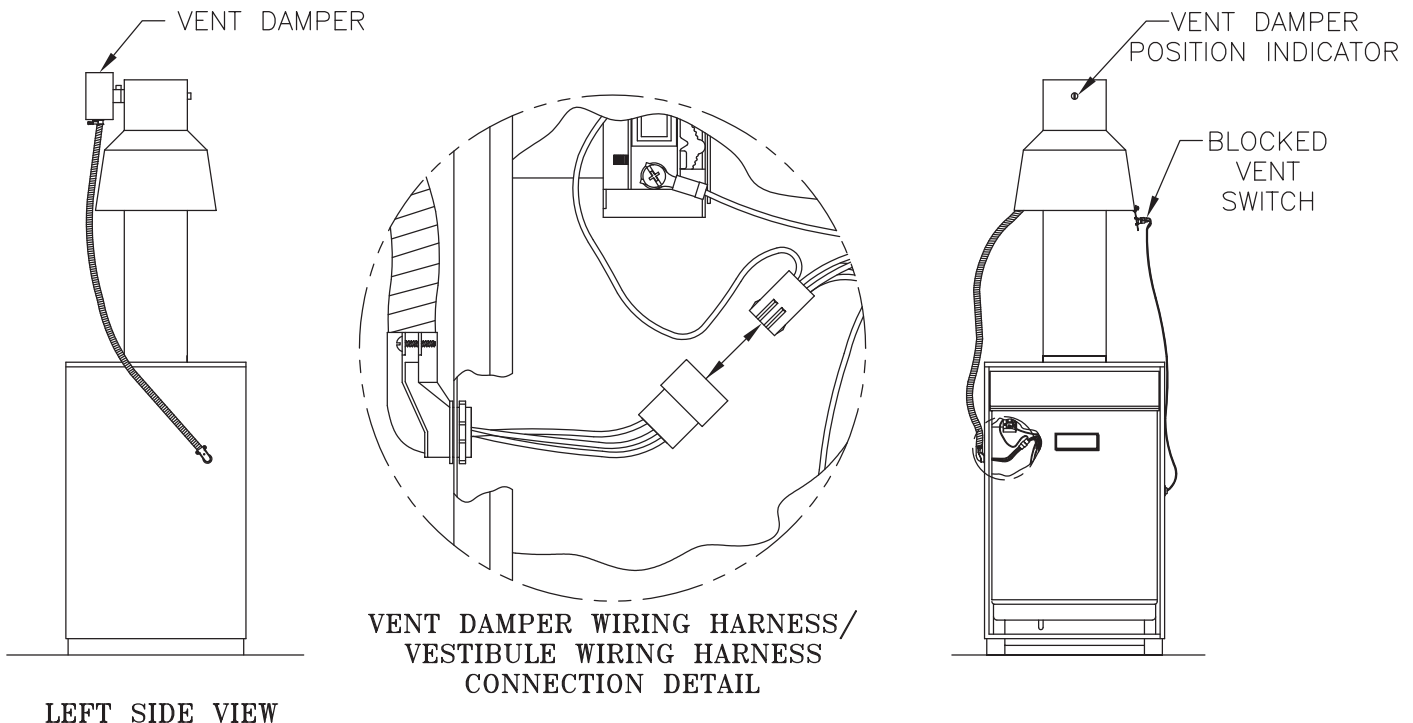

Figure 24: Vent Damper Installation

9. Design vent system for sea level input.
10. Provide adequate ventilation of Boiler Room. See Section I: Pre-Installation.
11. Never pass any portion of vent system through a circulating air duct or plenum.

WARNING

When an existing boiler is removed from a common venting system, the common venting system is likely to be too large for proper venting of the appliances remaining connected to it.

G. If an Existing Boiler is Removed:

When removing an existing boiler, the following steps shall be followed with each operational appliance that remains connected to the common venting system, while the other appliances connected to the common venting system are not in operation:

1. Seal any unused openings in the common venting system.
2. Visually inspect the venting system for proper size and horizontal pitch and determine there is no blockage or restriction, leakage, corrosion, or other deficiencies which could cause an unsafe condition.
3. Insofar as is practical, close all building doors and windows and all doors between the space in which the appliances remaining connected to the common

venting system are located and other spaces of the building. Turn on clothes dryers and any appliance not connected to the common venting system. Turn on any exhaust fans, such as range-hoods and bathroom exhausts, so they will operate at maximum speed. Do not operate a summer exhaust fan. Close fireplace dampers.

4. Place in operation the appliance being inspected. Follow the Lighting (or Operating) Instructions. Adjust thermostat so appliance will operate continuously.
5. Test for spillage at the draft hood relief opening after 5 minutes of main burner operation. Use the flame of a match or candle, or smoke from a cigarette, cigar or pipe.
6. After it has been determined that each appliance remaining connected to the common venting system properly vents when tested as outlined above, return doors, windows, exhaust fans, fireplace dampers and any other gas-burning appliance to their previous condition of use.
7. Any improper operation of the common venting system should be corrected so the installation conforms with the *National Fuel Gas Code*, NFPA 54/ANSI Z223.1. When resizing any portion of the common venting system, the common venting system should be resized to approach the minimum size as determined using the appropriate tables in Part 7 and Part 11 in the *National Fuel Gas Code*, NFPA 54/ANSI Z223.1.

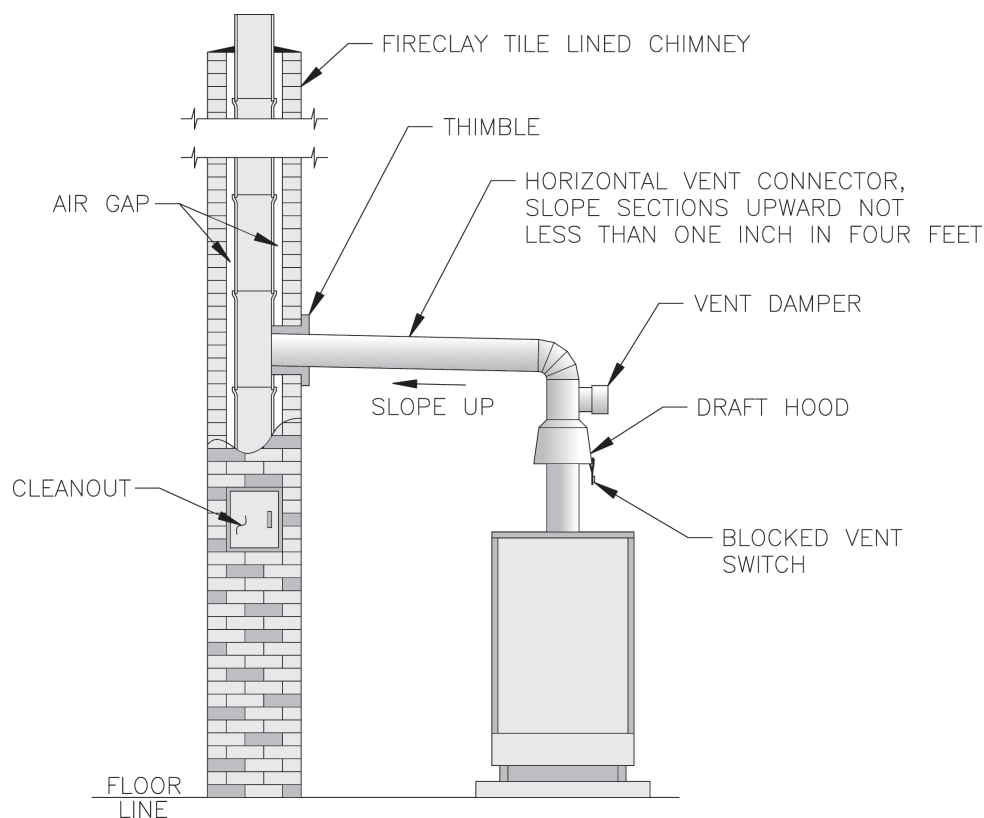

Figure 25: Typical Vent System

VII. Electrical

DANGER

Positively assure all electrical connections are unpowered before attempting installation or service of electrical components or connections of the boiler or building. Lock out all electrical boxes with padlock once power is turned off.

WARNING

Failure to properly wire electrical connections to the boiler may result in serious physical harm.

Electrical power may be from more than one source. Make sure all power is off before attempting any electrical work.

Each boiler must be protected with a properly sized fused disconnect.

Never jump out or make inoperative any safety or operating controls.

The wiring diagrams contained in this manual are for reference purposes only. Each boiler is shipped with a wiring diagram attached to the front door. Refer to this diagram and the wiring diagram of any controls used with the boiler. Read, understand and follow all wiring instructions supplied with the controls.

A. Install Boiler Wiring

1. Locate wiring harnesses in Combination Boiler Parts and Control Carton. Refer to Table 10 and connect wiring as shown on the appropriate wiring diagram.
2. Connect supply wiring and electrically ground boiler in accordance with requirements of authority having jurisdiction, or in absence of such requirements the *National Electrical Code, ANSI/NFPA 70*.

B. Wire Vent Damper (if used; optional on 16H-340 thru 16H-505). See Figure 24.

1. Attach Vent Damper Harness to mounting hole in Jacket Left Side Panel. Install Cable Clamp around flexible conduit and attach to Jacket Top Panel.
2. Remove factory installed Jumper Plug from Vent Damper Receptacle on Vestibule Wiring Harness and discard.
3. Plug Vent Damper Harness Plug into Vent Damper Receptacle. See Figure 24.

- #### C. Install thermostat.
- Locate on inside wall approximately 4 feet above floor. Do not install on outside wall, near fireplace, or where influenced by drafts or restricted air flow, hot or cold pipes, lighting fixtures, television, or sunlight. Allow free air movement by avoiding placement of furniture near thermostat.

Set heat anticipator to match control system requirements. Refer to Table 9.

- #### D. Wire thermostat.
- Provide Class II circuit between thermostat and boiler. Refer to appropriate wiring diagram for control system being used.

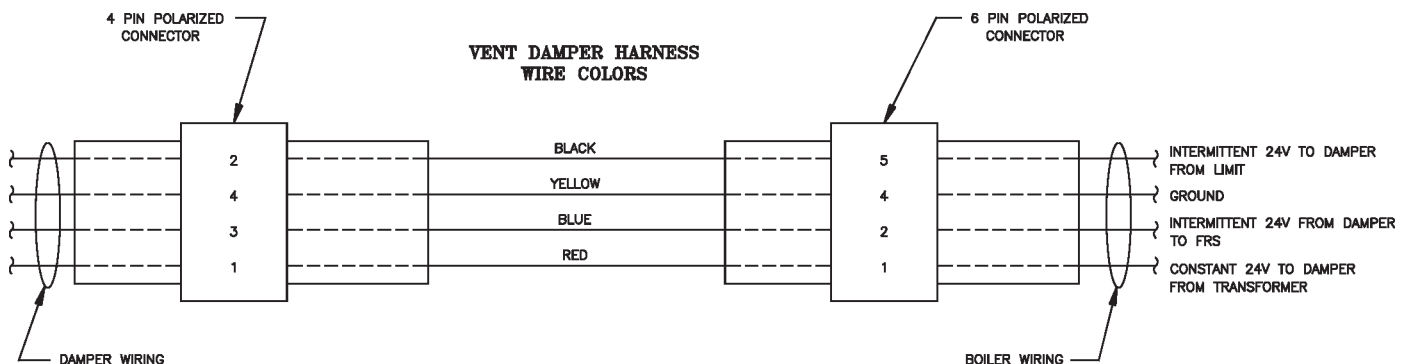

Figure 26: Vent Damper Schematic Wiring Diagram (16H-340 - 16H-505)

E. MegaStor Water Heater (if used). May be used with Intermittent Circulation only.

Refer to MegaStor Installation, Operating and Service Instructions for wiring, piping and additional information.

F. Vent Damper Sequence of Operation. See Figure 26 for schematic wiring diagram (16H-340 - 16H-505).

1. The Vent Damper is continuously powered at Terminal 1.
2. When there is a call for heat, the damper relay coil is energized through Terminal 5 if all limits ahead of the damper are satisfied.
3. The relay coil closes contacts which energize the damper motor, causing the damper to open.
4. When the damper blade reaches the fully open position, power is sent back to the ignition circuit through Terminal 2 and the damper motor is de-energized.

5. When the call for heat is satisfied, the damper relay coil is de-energized - closing contacts which energize the damper motor. This causes the damper to close. When the damper blade reaches the fully closed position, the damper motor is de-energized.

POWER FAILURE - The damper blade will stop in the position it was in when power failed. (Combustion can never take place unless the damper blade is in the fully open position).

G. Sequence of Operation and Wiring. Refer to Table 10 for the appropriate control system.

H. Optional Low-Water Cut-Off Wiring. See Figures 42 through 44.

Table 9: Heat Anticipator Settings

Control System	Heat Anticipator Setting*
	Intermittent Circulation
24V Electronic Ignition	0.3
* If room is heated above thermostat temperature setting, reduce heat anticipator setting by 0.1 or 0.2 amps. If boiler short cycles without room reaching desired temperature, increase heat anticipator by 0.1 or 0.2 amps.	

Table 10: Sequence of Operation and Wiring Diagrams

Ignition System	Country	Fuel	Boiler Sizes	Wiring Diagram Figure	Sequence of Operation
				Intermittent	
Intermittent Ignition (Honeywell EI - 24V)	USA	Natural Gas	7 - 10 Sect.	Figure 31	Page 30
		LP Gas			
Intermittent Ignition (EP-CSD-1 - 120V)	USA	Natural Gas	8 - 10 Sect.	Figure 35	Page 32

1. Honeywell EI Sequence of Operation

a. Normal Operation

- i.* Thermostat or operating control calls for heat. Vent Damper (if used) opens.
- ii.* Ignition Module Terminals PV, MV/PV and the Ignition Terminal are energized. Terminals PV and MV/PV power the Pilot Valve in the Gas Valve supplying gas to the Pilot. The Ignition Terminal supplies voltage to the Ignition Electrode creating an electric spark to ignite the Pilot.
- iii.* The sensing Circuit between the Q3481B Pilot Burner and the IGNITION MODULE proves the presence of the Pilot Flame Electronically and the Ignition Terminal is de-energized.
- iv.* Terminals MV and MV/PV of the IGNITION MODULE are energized and supply power to the Main Gas Valve. The Gas Valve is energized allowing main gas flow, and ignition of Main Burners.
- v.* Call for heat ends. Ignition module is de-energized, de-energizing gas valve, and extinguishing pilot and main flame. Vent Damper (if used) closes.

b. Safety Shutdown

- i.* Limit: Automatically interrupts power to the Ignition Module and Gas Valve(s), extinguishing pilot and main flame, when water temperature exceeds set point. Maximum allowable temperature is 250°F. Circulator continues to operate with call for heat, Vent Damper (if used) closes. Normal operation resumes when water temperature falls below set point.
- ii.* Blocked Vent Switch: Automatically interrupts main burner operation when excessive flue gas spillage occurs.

Circulator continues to operate and Vent Damper (if used) remains open with call for heat. If blocked vent switch is activated do not attempt to place boiler in operation. Correct cause of spillage and reset blocked vent switch.

- iii.* Flame Roll-out switch: Automatically interrupts main burner operation when flames or excessive heat are present in vestibule. Circulator continues to operate, Vent Damper (if used) remains open with call for heat. Control is single use device. If flame roll-out switch is activated, do not attempt to place boiler in operation. Correct cause of spillage and replace flame roll-out switch.

iv. Pilot

- Pilot failure can occur during the start-up or the operating cycle of the boiler. Any pilot failure of the Q3481B Electronic Pilot, after ignition of pilot flame will close the main gas valve in 0.8 seconds.
- For approximately 90 seconds after failure of the Q3481B pilot, the module through the ignition terminal will try to reestablish pilot flame. If no pilot flame can be sensed by the flame rod circuit, terminals PV and MV/PV are de-energized and the module will lock out on safety. Five to six minutes after shutdown, the IGNITION MODULE restarts the ignition sequence. The ignition trial, shutdown, and wait sequence continues until either the pilot lights or the Thermostat is set below room temperature (to end the call for heat). The ignition sequence can be reset by setting down the Thermostat for one minute.

c. Trouble Shooting Guide. See Page 48.

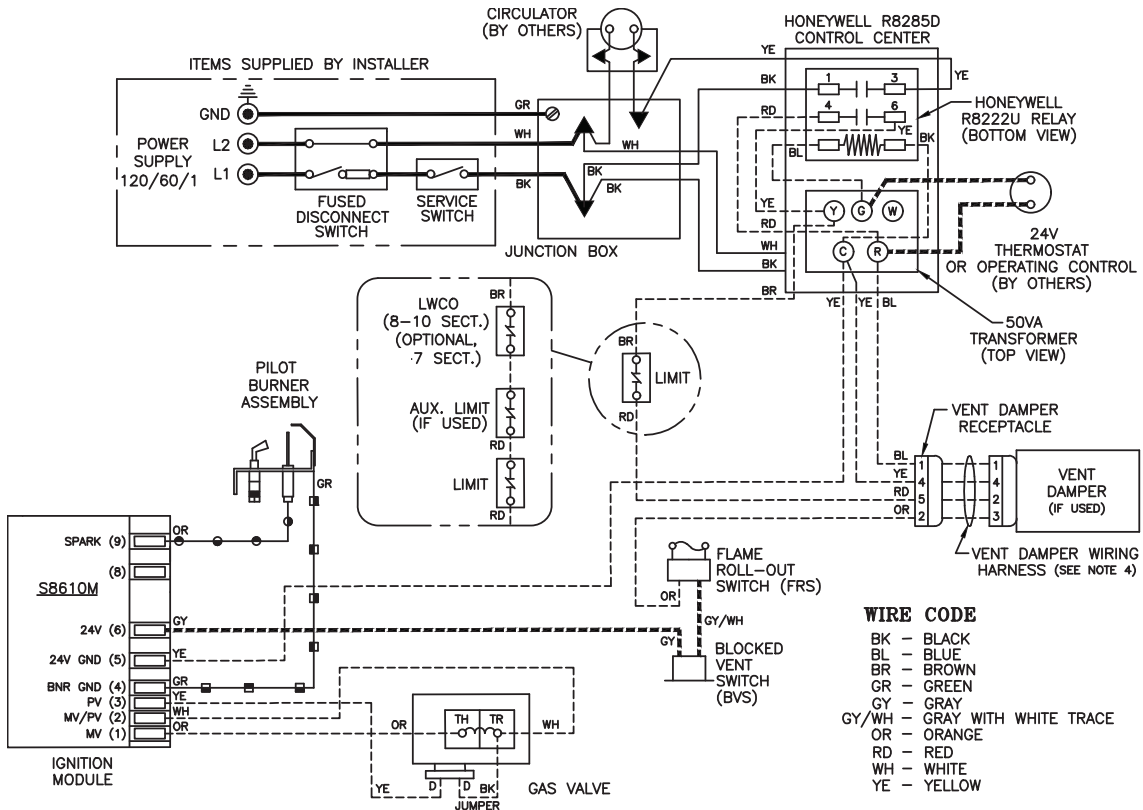

SCHEMATIC DIAGRAM LEGEND

- LOW VOLTAGE SIZE 18 AWG TYPE TEW/AWM STRANDED WIRE - 105°C
- LOW VOLTAGE SIZE 18/2 AWG TYPE CL2X STRANDED WIRE - 105°C
- ===== LINE VOLTAGE SIZE 14 AWG TYPE TW OR TEW/AWM WIRE
- ===== LINE VOLTAGE SIZE 18 AWG TYPE TW OR TEW/AWM WIRE
- HONEYWELL IGNITER/SENSOR CABLE - 250°C
- GROUND - SIZE 18 AWG TYPE SF-2/SEW-2, STRANDED WIRE, 1/32" THK INSULATION - 200°C.

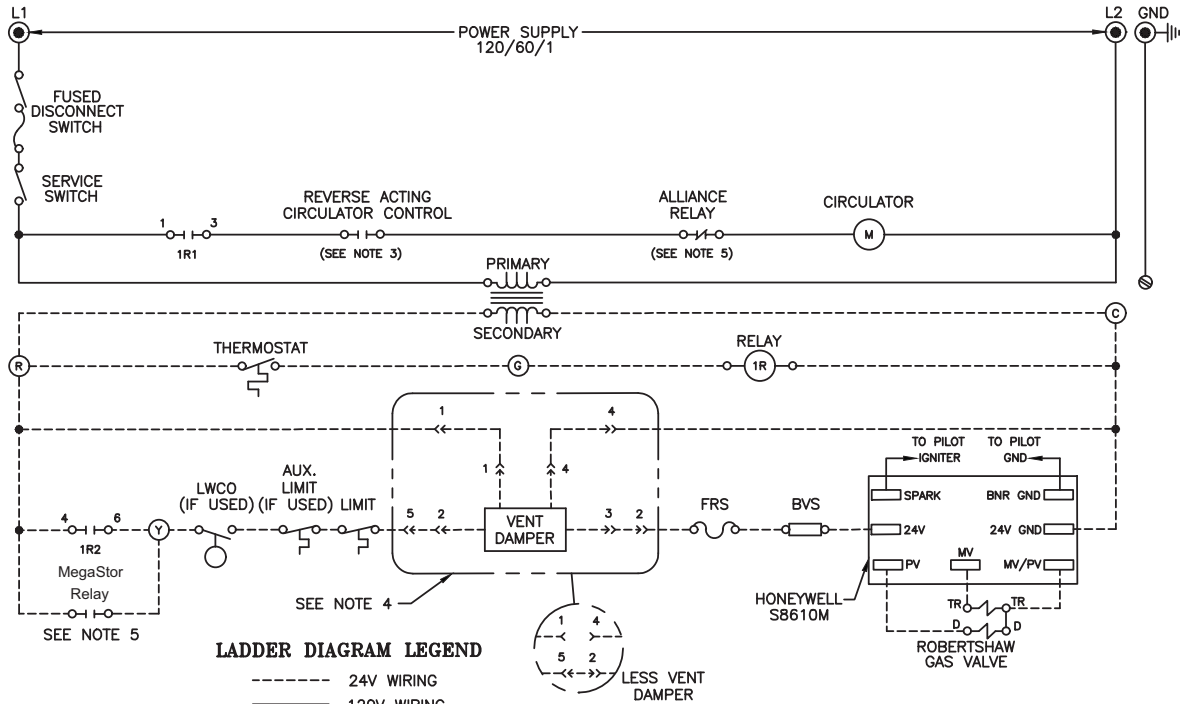

NOTES:

1. IF ANY OF THE ORIGINAL WIRE AS SUPPLIED WITH THE APPLIANCE MUST BE REPLACED, IT MUST BE REPLACED WITH WIRE AS SHOWN OR ITS EQUIVALENT.
2. SECOND LIMIT INCLUDED WITH PACKAGED BOILER, INSTALLER SUPPLIED FOR KNOCKDOWN BOILER.
3. ADDITIONAL LIMITS (TEMPERATURE, LOW WATER CUT-OFF, ETC.) SUPPLIED BY INSTALLER.
4. FOR BOILER LESS VENT DAMPER ONLY: VENT DAMPER WIRING HARNESS REPLACED WITH JUMPER PLUG.
5. MegaStor WATER HEATER CONTROLS SUPPLIED BY INSTALLER (SHOWN FOR DOMESTIC WATER PRIORITY AND CIRCULATOR ZONING).

Figure 31: Wiring Diagram, Honeywell EI, USA, Intermittent Circulation (16H-340 - 16H-510)

2. Electronically Supervised Intermittent Ignition (EP-CSD-1) Sequence of Operation

a. Normal Operation

- i.* Thermostat or operating control calls for heat.
- ii.* Terminal #6 of RM7890A Burner Control is energized, initiating a microcomputer monitored circuit test.
- iii.* The pilot valve (terminal 8) and ignition transformer (terminal 10) are energized. The pilot valve opens and the ignition electrode sparks, igniting the pilot.
- iv.* After the pilot flame is proven, the ignition terminal (10) is de-energized and the main valve terminal (9) is energized, allowing main gas flow and ignition of main burners. "Main" gas light will be illuminated.
- v.* When the call for heat ends, terminal #6 is de-energized, extinguishing the pilot and main flames. "Main" gas light is de-energized.

b. Safety Shutdown

- i.* Limit: Automatically interrupts main burner operation when water temperature exceeds set point. Maximum allowable temperature is 250°F. Circulator continues to operate with call for heat. Normal operation resumes when water temperature falls below set point.

- ii.* Blocked Vent Switch: Automatically interrupts main burner operation when excessive flue gas spillage occurs. Circulator continues to operate with call for heat. If blocked vent switch is activated, do not attempt to place boiler in operation. Correct cause of spillage and reset blocked vent switch.
- iii.* Flame Roll-out Switch: Automatically interrupts main burner operation when flames or excessive heat are present in vestibule. Circulator continues to operate with call for heat. Control is single use device. If flame roll-out switch is activated, do not attempt to place boiler in operation. Correct cause of spillage and replace flame roll-out switch.
- iv.* RM7890A Burner Control: Automatically interrupts main burner operation if a pilot flame is not detected during the four or ten second pilot flame establishing period. The RM7890A will lockout or recycle based on jumper settings. "Alarm" light will be illuminated. Refer to instructions supplied with RM7890A for additional control information.

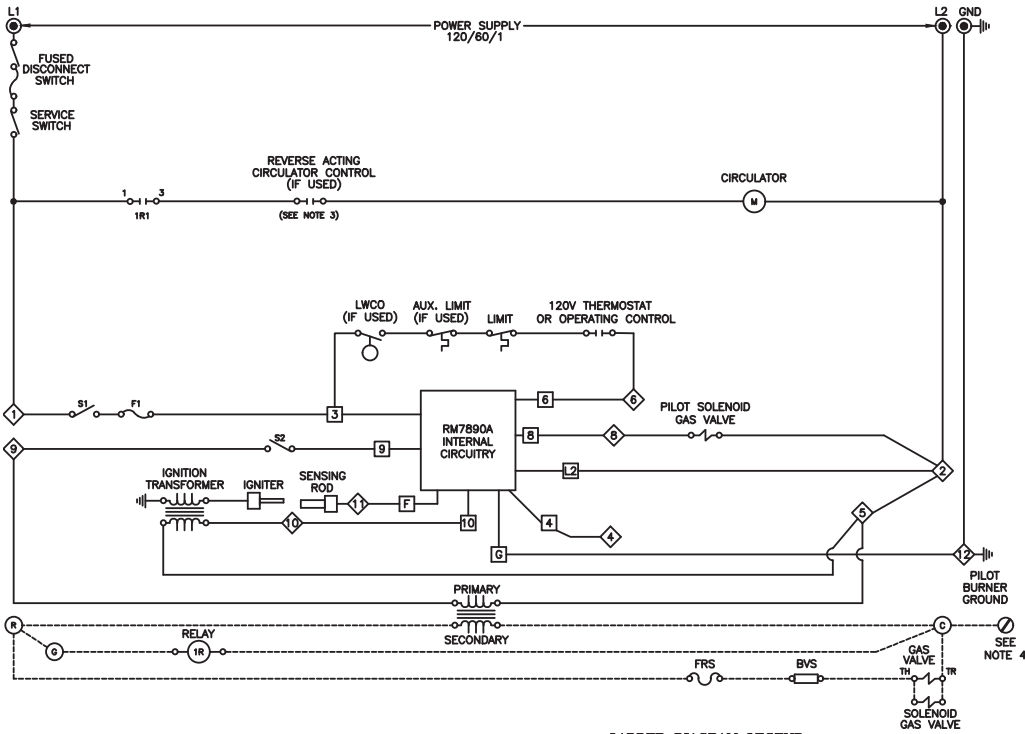
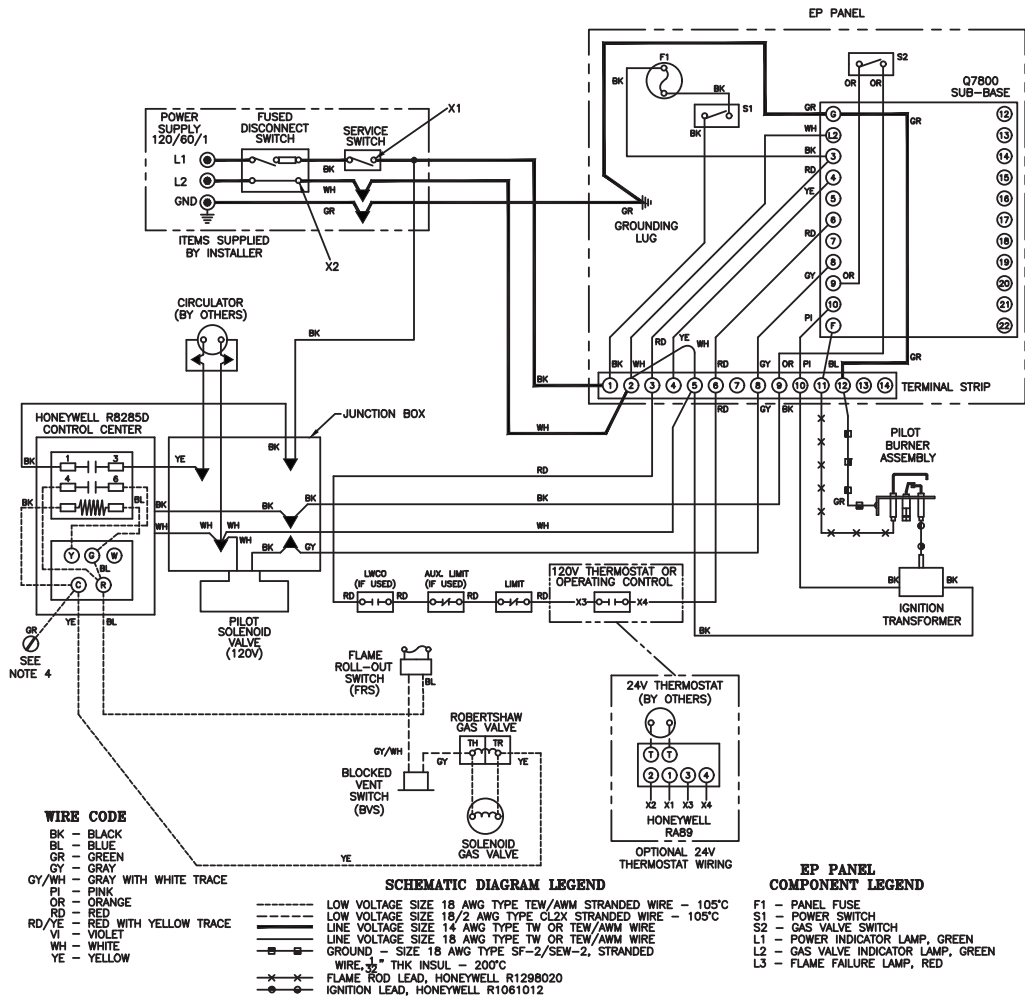

Figure 35: Wiring Diagram, EP Ignition System, Natural Gas Only, Intermittent Circulation (EP-CSD-1; Natural Gas, USA Only, 16H-410 - 16H-505)

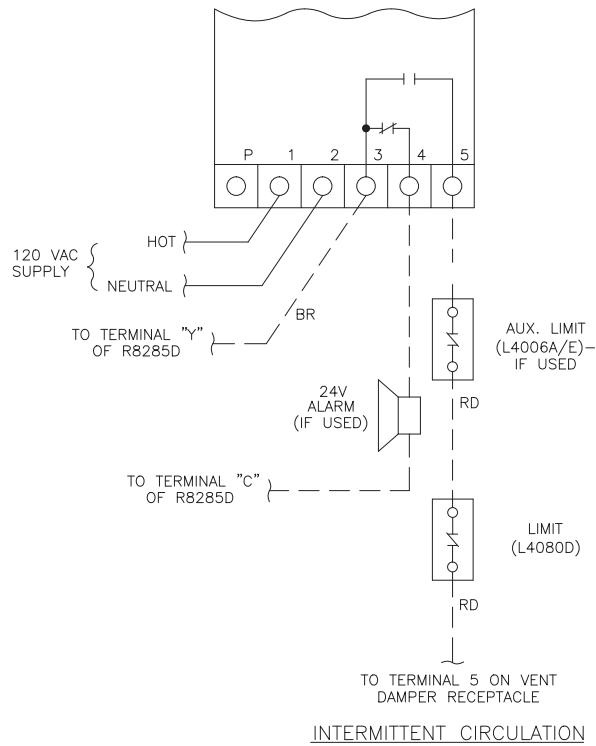

Figure 36: McDonnell & Miller 751P-MT (120V) L.W.C.O. Wiring for Boilers with 24V Limit Circuits (EI) (16H-340 - 16H-505)

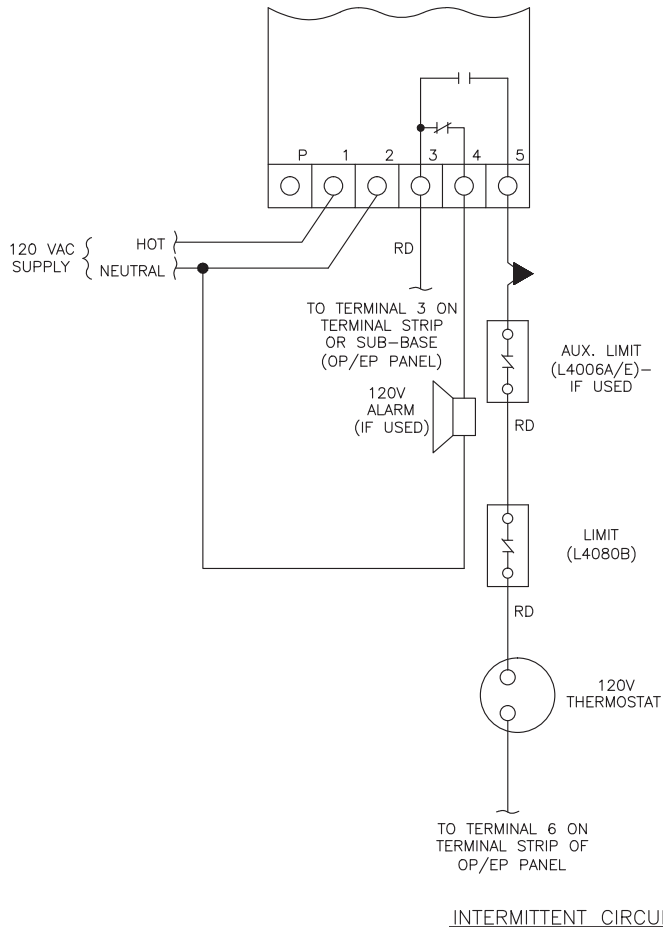
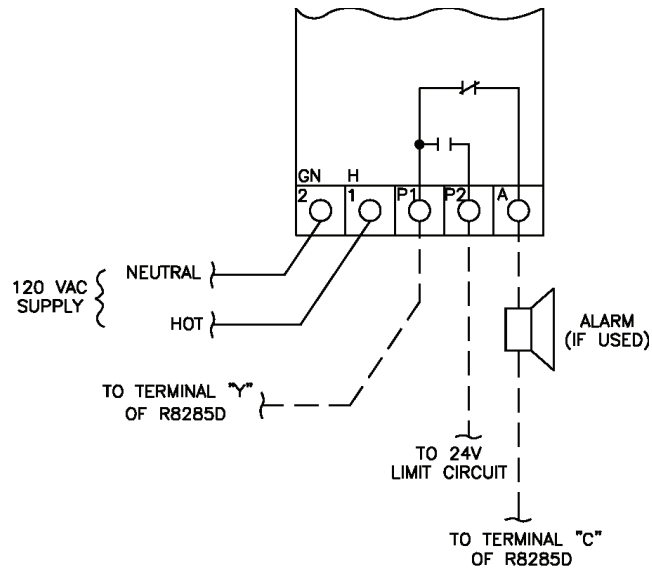
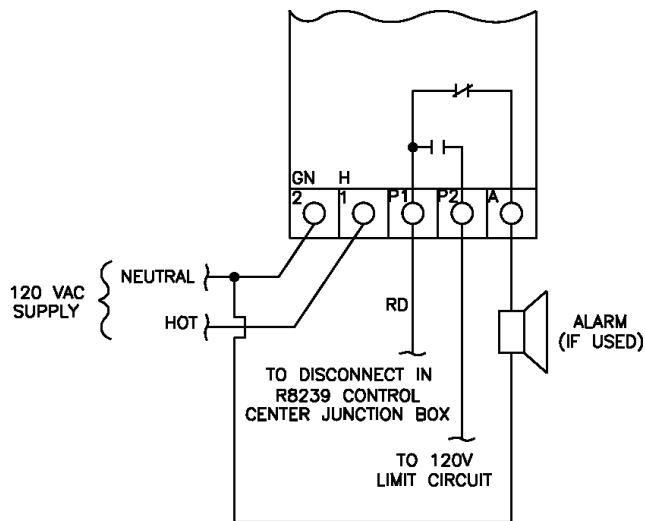

Figure 37: McDonnell & Miller 751P-MT (120V) L.W.C.O. Wiring for Boilers with 120V Limit Circuits (EP-CSD-1) (16H-410 - 16H-505)



INTERMITTENT CIRCULATION

Figure 38: Hydrolevel OEM - 170/550/650/750 (120V) L.W.C.O. Wiring for Boilers with 24V Limit Circuits (EI) (16H-340 - 16H-505)



INTERMITTENT CIRCULATION

Figure 39: Hydrolevel OEM - 170/550/650/750 (120V) L.W.C.O. Wiring for Boilers with 120V Limit Circuits (EP-CSD-1) (16H-410 - 16H-505)

VIII. System Start-Up

WARNING

Completely read, understand and follow all instructions in this manual before attempting start-up.

- A. Safe operation** and other performance criteria were met with the gas manifold and control assembly provided on boiler when boiler underwent tests specified in *American National Standard for Gas-Fired Low-Pressure Steam and Hot Water Boilers*, ANSI Z21.13.
- B. Check Main Burners.** Main burners must be properly located on support bracket in Base Rear Panel, seated on Main Burner Orifices, and secured with hitch pin clips.
- C. Verify that the venting, water piping, gas piping and electrical system** are installed properly. Refer to installation instructions contained in this manual.
- D. Confirm all electrical, water and gas supplies** are turned off at the source and that vent is clear of obstructions.
- E. FILL ENTIRE HEATING SYSTEM WITH WATER** and vent air from system. Use following procedure on a Series Loop or multi-zoned system installed as per Figure 21 to remove air from system when filling.

WARNING

The maximum operating pressure of this boiler is 50 psig. Never exceed this pressure. Do not plug or modify pressure relief valve.

1. Close full port ball valve in boiler supply piping.
2. Isolate all zones by closing zone valves or shut-off valves in supply and return of each zone(s).
3. Attach a hose to the vertical purge valve located prior to the full port ball valve in the system supply piping. (Note - Terminate hose in five gallon bucket at a suitable floor drain or outdoor area).
4. Starting with one circuit at a time, open zone valve or shut-off valve in system supply and return piping.
5. Open purge valve.
6. Open fill valve (Make-up water line should be located directly after full port ball valve in system supply piping between air scoop and expansion tank).
7. Allow water to overflow from bucket until discharge from hose is bubble free for 30 seconds.
8. Close the open zone valve or shut-off valve for the zone being purged of air, then open the zone valve or shut-off valve for the next zone to be purged. Repeat this step until all zones have been purged. At completion, open all zone valves or shut-off valves.

9. Close purge valve, continue filling the system until the pressure gauge reads the desired cold fill pressure. Close fill valve.
(Note - If make-up water line is equipped with pressure reducing valve, adjust pressure reducing valve to desired cold fill pressure. Follow fill valve manufacturer's instructions).
10. Open isolation valve in boiler supply piping.
11. Remove hose from purge valve.

F. Confirm that the boiler and system have no water leaks.

G. Prepare to check operation.

1. Obtain gas heating value (in Btu per cubic foot) from gas supplier.
2. Connect manometer to pressure tap on gas valve. Use 1/8 NPT tapping provided.
3. Temporarily turn off all other gas-fired appliances.
4. Turn on gas supply to the boiler gas piping.
5. Confirm that the supply pressure to the gas valve is 14 in. w.c. or less.
6. Open the field installed manual gas shut-off valve located upstream of the gas valve on the boiler.
7. Using soap solution, or similar non-combustible solution, electronic leak detector or other approved method. Check that boiler gas piping, valves, and all other components are leak free. Eliminate any leaks.
8. Purge gas line of air.

H. Follow Lighting or Operating Instructions to place boiler in operation. Refer to label on inside of Front Removable Panel or appropriate Figure as listed in Table 11.

DANGER

Do not use matches, candles, open flames or other ignition source to check for leaks.

Table 11: Lighting and Operating Instructions

Ignition System	Lighting and Operating Instructions	Pilot Flame Illustration
Honeywell EI	Figure 41	Figure 45
EP-CSD-1	Figure 43	Figure 46

FOR YOUR SAFETY READ BEFORE OPERATING

WARNING: If you do not follow these instructions exactly, a fire or explosion may result causing property damage, personal injury, or loss of life.

- A. This appliance is equipped with an ignition device which automatically lights the pilot. Do not try to light the pilot by hand.
- B. BEFORE OPERATING smell all around the appliance area for gas. Be sure to smell next to the floor because some gas is heavier than air and will settle on the floor.
- WHAT TO DO IF YOU SMELL GAS:**
- Do not try to light any appliance.
 - Do not touch any electric switch; do not use any phone in your building.
 - Immediately call your gas supplier from a neighbor's phone. Follow the gas supplier's instructions.
- If you cannot reach your gas supplier, call the fire department.
- C. Use only your hand to turn the gas control knob. Never use tools. If the knob will not turn by hand, don't try to repair it, call a qualified service technician. Force or attempted repair may result in a fire or explosion.
- D. Do not use this appliance if any part has been under water. Immediately call a qualified service technician to inspect the appliance and to replace any part of the control system and any gas control which has been under water.

OPERATING INSTRUCTIONS

1. STOP! Read the safety information above on this label.
2. Set the thermostat to lowest setting.
3. Turn off all electric power to the appliance.
4. This appliance is equipped with an ignition device which automatically lights the pilot. Do not try to light the pilot by hand.
5. Remove front door.
6. Locate the gas control valve at the end of the gas supply pipe going into the boiler. The gas control knob is the gray or brown plastic knob located on top of the gas control valve.
7. Rotate gas control knob clockwise ↻ from "ON" position to "OFF". Make sure knob rests against stop.
8. Wait five (5) minutes to clear out any gas. Then smell for gas, including near the floor. If you smell gas, STOP! Follow "B" in the safety information above on this label. If you do not smell gas, go to the next step.
9. Rotate gas control knob counterclockwise ↻ from "OFF" to "ON". Make sure knob rests against stop. Do not force.
10. Replace front door.
11. Turn on all electric power to the appliance.
12. Set thermostat to desired setting.
13. If the appliance will not operate, follow the instructions "TO TURN OFF GAS TO APPLIANCE" and call your service technician or gas supplier.

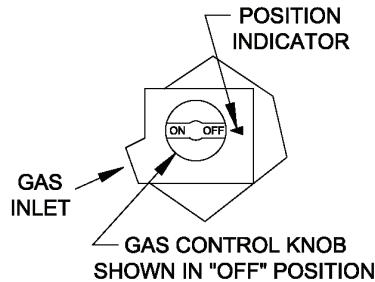

TO TURN OFF GAS TO APPLIANCE

1. Set the thermostat to the lowest setting.
2. Turn off all electric power to the appliance if service is to be performed.
3. Remove front door.
4. Rotate gas control knob clockwise ↻ from "ON" position to "OFF". Make sure knob rests against stop.
5. Replace front door.

Figure 41: Operating Instructions (EI)

FOR YOUR SAFETY READ BEFORE OPERATING

WARNING: If you do not follow these instructions exactly, a fire or explosion may result causing property damage, personal injury, or loss of life.

- A. This appliance is equipped with an ignition device which automatically lights the pilot. Do not try to light the pilot by hand.
- B. BEFORE OPERATING smell all around the appliance area for gas. Be sure to smell next to the floor because some gas is heavier than air and will settle on the floor.
- WHAT TO DO IF YOU SMELL GAS:**
- * Do not try to light any appliance.
 - * Do not touch any electric switch; do not use any phone in your building.
 - * Immediately call your gas supplier from a neighbor's phone. Follow the gas supplier's instructions.
- * If you cannot reach your gas supplier, call the fire department.
- C. Use only your hand to push in or turn the gas control knob. Never use tools. If the knob will not push in or turn by hand, don't try to repair it, call a qualified service technician. Force or attempted repair may result in a fire or explosion.
- D. Do not use this appliance if any part has been under water. Immediately call a qualified service technician to inspect the appliance and to replace any part of the control system and any gas control which has been under water.

OPERATING INSTRUCTIONS

1. STOP! Read the safety information above on this label.
2. Set the thermostat to lowest setting.
3. Turn off all electric power to the appliance.

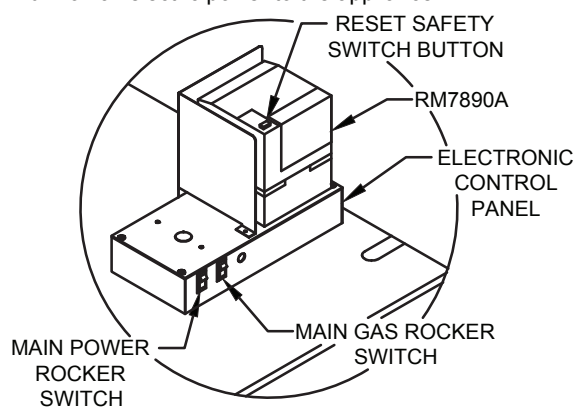

CONTROL LOCATION DIAGRAM

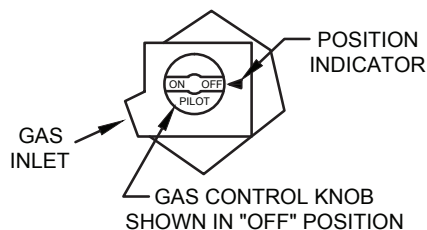

4. **EP SYSTEM:** Flip both rocker switches to "O" position (off).
5. This appliance is equipped with an ignition device which automatically lights the pilot. Do not try to light the pilot by hand.
6. Remove front door.
7. Open manual pilot valve (CSD-1 Boilers Only).
8. Locate the gas control valve at the end of the gas supply pipe going into the boiler. The gas control knob is the knob located on top of the gas valve (see diagram to right).
9. Rotate gas control knob clockwise from "ON" position to "OFF". Make sure knob rests against stop.
10. Wait five (5) minutes to clear out any gas. Then smell for gas, including near the floor. If you smell gas, STOP! Follow "B" in the safety information above on this label. If you do not smell gas, go to the next step.
11. Turn gas control knob counterclockwise from "OFF" to "PILOT". When the proper position is reached the gas control knob will pop up.
12. Turn on all electric power to the appliance.
13. Set the thermostat or operating control to desired setting.
14. **EP SYSTEM**
 - See control location diagram. On the electronic control panel, flip the main power rocker switch to "I" position (on). The "POWER" status indicator will light.
 - The pilot will light electronically. If pilot failure occurs, the "ALARM" indicator will light. In case of pilot failure, proceed to step 11.
 - Turn gas control knob counterclockwise to "ON".
 - On the electronic control panel, flip the main gas valve rocker switch to "I" position (on). The "MAIN" gas valve indicator will light. Main burners will operate. "MAIN" gas valve indicator will cycle on and off at the same time as the thermostat or operating control and the main burners.
15. Replace front door.
16. If the appliance will not operate, follow the instructions "TO TURN OFF GAS TO APPLIANCE" and call your service technician or gas supplier.

TO TURN OFF GAS TO APPLIANCE

1. Set the thermostat to the lowest setting.
2. Turn off all electric power to the appliance if service is to be performed.
3. Remove front door.
4. Rotate gas control knob clockwise from "ON" position to "OFF". Make sure knob rests against stop.
5. Close manual pilot valve (CSD-1 Boilers Only).
6. Replace front door.

81460284R4

Figure 43: Operating Instructions (EP-CSD-1)

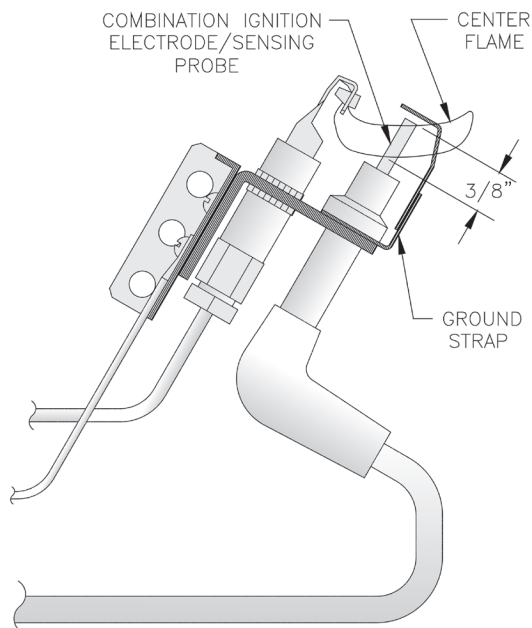

Figure 45: Honeywell Q3481B Pilot Flame (24V Electronic Ignition)

- I. Check pilot burner flame and main burner flames through observation port.**
1. Check pilot flame. Refer to Table 11 for appropriate pilot detail.
 2. Adjust thermostat to highest setting.
 3. Check main burner flames. See Figure 47. Flame should have clearly defined inner cones with no yellow tipping. Orange-yellow streaks caused by dust should not be confused with true yellow tipping.
- Yellow-tipping indicates lack of primary air. Improper burner alignment on Main Burner Orifice will also affect primary air injection. Adjust primary air as follows:

CAUTION

Avoid operating this boiler in an environment where saw dust, loose insulation fibers, dry wall dust, etc. are present. If boiler is operated under these conditions, the burner interior and ports must be cleaned and inspected daily to insure proper operation.

- a. Loosen lock screw.
 - b. Close air adjustment until yellow tips appear on flames.
 - c. Slowly open air adjustment until clearly defined inner cones are visible.
 - d. Tighten lock screw.
4. Adjust thermostat to normal setting.

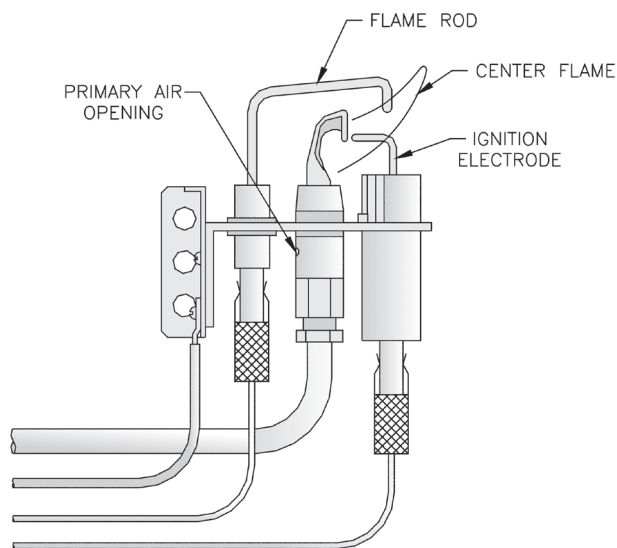

Figure 46: Honeywell Q179C Pilot Flame (EP)

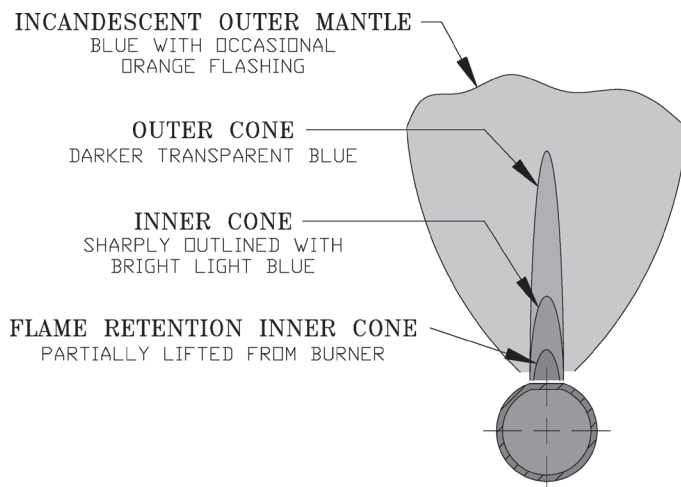

Figure 47: Main Burner Flame

J. Check thermostat or operating control operation.

Raise and lower temperature setting to start and stop boiler operation.

K. Check ignition system shut-off.

1. Honeywell EI: Disconnect ignitor/sensor cable from ignition module. Gas valve must close and pilot and main burners extinguish. If not, measure voltage across gas valve terminals “TH” and “TR”.
 - a. If voltage is not present, replace gas valve.
 - b. If voltage is present, replace ignition module.
2. EP: Refer to instructions supplied with the Honeywell RM7890 Burner Control.

L. Check Limit(s).

1. Adjust thermostat to highest setting.
2. Observe temperature gauge. When temperature exceeds limit set point main burners should extinguish.
3. Adjust limit to setting above observed reading. Main burners should reignite.
4. Adjust thermostat to lowest setting. Adjust limit to desired setting.

M. Adjust gas input rate to boiler. Natural Gas.

1. Adjust thermostat to highest setting.
2. Check manifold gas pressure. Manifold pressure is listed on rating label. Adjust gas valve pressure regulator as necessary (turn adjustment screw counterclockwise to decrease manifold pressure, or clockwise to increase manifold pressure). If pressure can not be attained, check gas valve inlet pressure.
If less than minimum gas supply pressure listed on rating label, contact gas supplier for assistance.
3. Clock gas meter for at least 30 seconds. Use Table 12 to determine gas flow rate in Cubic Feet per Hour.
4. Determine Input Rate. Multiply gas flow rate by gas heating value.

Warning

Failure to properly adjust gas input rate will result in over firing or under firing of the appliance. Improper and unsafe boiler operation may result.

5. Compare measured input rate to input rate stated on rating label.
 - a. Boiler must not be overfired. Reduce input rate by decreasing manifold pressure. Do not reduce more than 0.3 inch w.c. If boiler is still overfired, contact your Crown distributor or Regional Office for replacement Gas Orifices.
 - b. Increase input rate if less than 98% of rating plate input. Increase manifold gas pressure no

Table 12: Input Rate

Seconds for One Revolution	Size of Gas Meter Dial			
	One-Half Cu. Ft.	One Cu. Ft.	Two Cu. Ft.	Five Cu. Ft.
30	60	120	240	600
32	56	113	225	563
34	53	106	212	529
36	50	100	200	500
40	45	90	180	450
38	47	95	189	474
40	45	90	180	450
42	43	86	172	430
44	41	82	164	410
46	39	78	157	391
48	37	75	150	375
50	36	72	144	360
52	35	69	138	346
54	33	67	133	333
56	32	64	129	321
58	31	62	124	310
60	30	60	120	300
62	29	58	116	290
64	29	56	112	281
66	29	54	109	273
68	28	53	106	265
70	26	51	103	257
72	25	50	100	250
74	24	48	97	243
76	24	47	95	237
78	23	46	92	231
80	22	45	90	225

more than 0.3 inch w.c. If measured input rate is still less than 98% of rated input:

- i. Remove Main Burners per procedure in Section IX: Service.
- ii. Remove gas orifices. Drill one (1) drill size larger (drill size is stamped on orifice, or see Key No. 4E).
- iii. Reinstall gas orifices and main burners. Measure input rate.

6. Recheck Main Burner Flame.
7. Return other gas-fired appliances to previous conditions of use.

N. Adjust gas input rate to boiler. LP/Propane.

1. Set thermostat to highest setting.
2. Adjust tank regulator for gas valve inlet pressure of 13.5 inches w.c. or less.
3. Gas valve has step opening regulator which initially

opens to 1.4 or 2.5 inch w.c. and steps to full pressure after approximately 30 seconds. Check manifold pressure after step has occurred. Adjust gas valve pressure regulator as necessary for 10.0 inches w.c. (turn adjustment screw counterclockwise to decrease manifold pressure, or clockwise to increase manifold pressure). If 10.0 inches w.c. can not be attained, check gas valve inlet pressure. If less than 11.0 inches w.c., contact gas supplier for assistance.

O. Clean Heating System

Oil, grease, and other foreign materials which accumulate in new hot water boilers and a new or reworked system should be boiled out, and then thoroughly flushed. A qualified water treatment chemical specialist should be consulted for recommendations regarding appropriate chemical compounds and concentrations which are compatible with local environmental regulations.

P. Check Damper Operation - If boiler is equipped with vent damper, vent damper must be in open position when boiler main burners are operating. Start boiler, refer to instructions on damper to determine if damper

is in full open position.

Q. Install Front Removable Panel.

1. Engage top flange (longer of 2 flanges) behind Upper Front Panel.
2. Swing lower portion of door toward boiler.
3. Lower door to engage bottom flange behind Lower Front Tie Bar.

R. Combustion Chamber Burn-Off

1. The mineral wool combustion chamber panels contain a cornstarch based binder that must be burned out at installation to prevent odors during subsequent boiler operation.
2. Ventilate the boiler room, set the high limit to its maximum setting, set the thermostat to call for heat.
3. Allow the boiler to fire for at least an hour or until the odor from the cornstarch has dissipated.
4. Return the high limit and thermostat to their desired settings.

S. Review User's Information Manual and system operation with owner or operator.

IX. Service

WARNING

Service on this boiler should be undertaken only by trained and skilled personnel from a qualified service agency. Inspections should be performed at intervals specified in this manual. Maintain manual in a legible condition.

Keep boiler area clear and free of combustible materials, gasoline and other flammable vapors and liquids.

Do not place any obstructions in boiler room that will hinder flow of combustion and ventilation air.

The service instructions contained in this manual are in addition to the instructions provided by the manufacturer of the boiler components. Follow component manufacturer's instructions. Component manufacturer's instructions were provided with the boiler. Contact component manufacturer for replacement if instructions are missing. Do not install, start up, operate, maintain or service this boiler without reading and understanding all of the component instructions. Do not allow the boiler to operate with altered, disconnected or jumpered components. Only use replacement components identical to those originally supplied by Crown Boiler Company.

- A. General.** Inspection and service must be conducted annually. Turn off electrical power and gas supply while conducting service or maintenance. Follow instructions TO TURN OFF GAS TO APPLIANCE. See Lighting/ Operating Instructions on inside of Front Removable Door.

WARNING

Label all wires prior to disconnection when servicing controls. Wiring errors can cause improper and dangerous operation. Verify proper operation after servicing.

- B. Maintenance of Low Water Cut-off (if used).** Follow instruction manual provided with low water cut off.

- C. Vent System.** Check for:

1. obstructions
2. accumulations of soot
3. deterioration of vent pipe or vent accessories due to condensation or other reasons
4. proper support—no sags, particularly in horizontal runs
5. tightness of joints. Remove all accumulations of soot with wire brush and vacuum

Remove all obstructions. Replace all deteriorated parts and support properly. Seal all joints.

- D. Remove Main Burners** for cleaning, changing orifice plugs, or repairs.

1. Shut down gas boiler in accordance with Lighting/ Operating Instructions on inside of Front Removable Door. Close Manual Shut-off Valve.
2. Remove Front Removable Door. Raise Lower Front Tie Bar.
3. Disconnect ignition system.

4. Remove burner access panel(s).
5. Mark location of Main Burner with Pilot Bracket on manifold.
6. Remove hitch pin clips from Main Burner Orifices.
7. Hold Main Burner on throat. Lift slightly to raise rear of burner. Push to rear of boiler until burner clears Main Burner Orifice. Lift burners out.
8. Check burners to be sure they do not contain foreign matter or restrictions. Clean burners with a soft bristle brush, blow any dirt out with compressed air or use a vacuum cleaner. See Figure 48.

- E. Clean Boiler Flueways.** See Figure 48.

1. Shut down gas boiler in accordance with Lighting/ Operating Instructions on inside of Front Removable Door. Close Manual Shut-off Valve.
2. Disconnect vent system. Remove Draft Hood.
3. Remove Jacket Top Panel.
4. Remove Canopy from top of boiler.
5. Remove flue baffles. Refer to Figure 48 for instructions on how to remove baffles from flueways. Remove any accumulated scale or soot.
6. Thoroughly clean flueways with flue brush, removing all scale and soot. See Figure 48.
7. Clean boiler heating surface accessible from combustion chamber with straight handle wire brush.
8. Reinsert baffles into flueways by reversing steps given in Figure 48. Tabs at top of each baffle should rest on top of flue pins.
9. Install Canopy. See Section II: Boiler Assembly, Paragraph G.
10. Install Jacket Top Panel, Draft Hood, Vent Damper (if used) and Vent System.

Important Product Safety Information **Refractory Ceramic Fiber Product**

Warning:

The Repair Parts list designates parts that contain refractory ceramic fibers (RCF). RCF has been classified as a possible human carcinogen. When exposed to temperatures above 1805°F, such as during direct flame contact, RCF changes into crystalline silica, a known carcinogen. When disturbed as a result of servicing or repair, these substances become airborne and, if inhaled, may be hazardous to your health.

AVOID Breathing Fiber Particulates and Dust

Precautionary Measures:

Do not remove or replace RCF parts or attempt any service or repair work involving RCF without wearing the following protective gear:

1. A National Institute for Occupational Safety and Health (NIOSH) approved respirator
 2. Long sleeved, loose fitting clothing
 3. Gloves
 4. Eye Protection
- Take steps to assure adequate ventilation.
 - Wash all exposed body areas gently with soap and water after contact.
 - Wash work clothes separately from other laundry and rinse washing machine after use to avoid contaminating other clothes.
 - Discard used RCF components by sealing in an airtight plastic bag. RCF and crystalline silica are not classified as hazardous wastes in the United States and Canada.

First Aid Procedures:

- If contact with eyes: Flush with water for at least 15 minutes. Seek immediate medical attention if irritation persists.
- If contact with skin: Wash affected area gently with soap and water. Seek immediate medical attention if irritation persists.
- If breathing difficulty develops: Leave the area and move to a location with clean fresh air. Seek immediate medical attention if breathing difficulties persist.
- Ingestion: Do not induce vomiting. Drink plenty of water. Seek immediate medical attention.

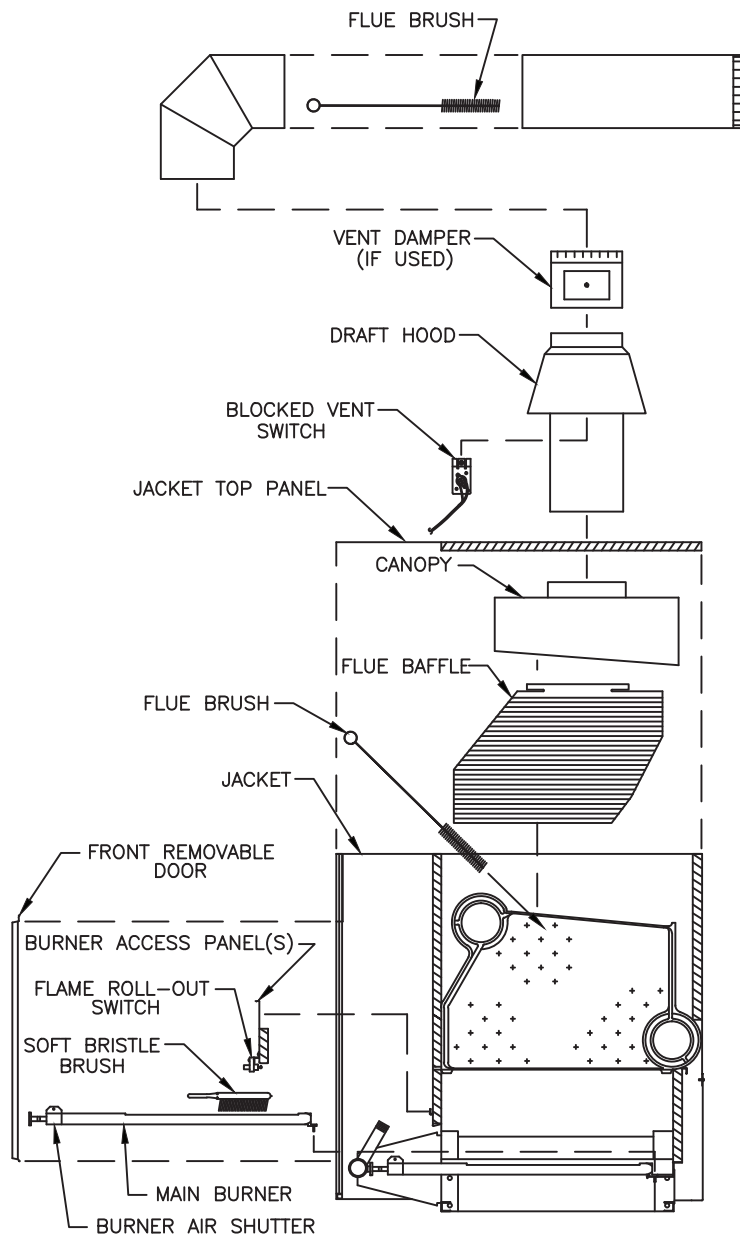

FLUE BAFFLE REMOVAL

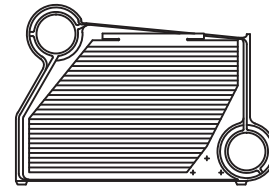

1. PULL UP FROM REAR CORNER OF BAFFLE.

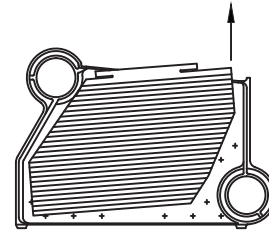

2. ROTATE BAFFLE INSIDE FLUEWAY WHILE CONTINUING TO RAISE REAR CORNER. IT MAY BE NECESSARY TO PUSH FRONT OF BAFFLE DEEPER INTO THE FLUEWAY TO COMPLETE THE ROTATION.

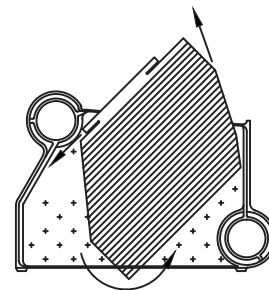

3. LIFT BAFFLE OUT OF FLUEWAY ONCE EDGES OF THE BAFFLE CLEAR THE EDGES OF THE FLUEWAY.

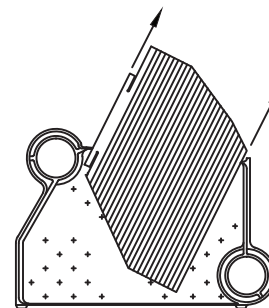

Figure 48: Boiler Flueway Cleaning

- F. Clean Combustion Chamber** by vacuuming. Exercise care to avoid damaging Base Insulation.
- G. Install Burners** by reversing procedures used to remove burners. Verify Main Burners are properly located on support bracket in Base Rear Panel, seated on Main Burner Orifices, and secured with hitch pin clips. Verify Main Burner with Pilot Bracket is in proper location. See Table 13.
- H. Lubrication.** Manufacturers Instruction should be followed on all parts installed on boiler requiring lubrication. This includes type of lubricant to be used, frequency of lubrication, and points to lubricate.
- I. Check operation.** Refer to Section VIII: System Start-up.

Table 13: Pilot Burner Location

Boiler Model	Pilot Located Between Burners*
16H-340	6 & 7
16H-410	6 & 7
16H-460	7 & 8
16H-505	8 & 9

* Burners numbered left to right as viewed from front of boiler.

Honeywell EI Ignition Module Yellow LED Flame Codes

Yellow LED Flash Code ^a	Indicates	Recommended Service Action
Heartbeat	Normal Flame Signal	N/A
2	Weak Flame Signal - System will operate reliably but flame signal is less than desired. Note: This indication may flash temporarily during or shortly after lightoff on some applications.	Perform routine maintenance to assure optimum flame signal.
1	Marginal Flame Signal (less than 1.1 μ A) - System may not operate reliably over time. Service call recommended. Note: This indication may flash temporarily during or shortly after lightoff on some applications.	Check gas supply, pilot burner, flame sense wiring, contamination of flame rod, burner ground connection.
OFF	No Flame or Flame Signal - below minimum threshold for system operation.	N/A

^aFlash Code Descriptions

- Heartbeat: Constant ½ second bright, ½ second dim cycles.
- The flash code number signifies that the LED flashes X times at 2Hz, remains off for two seconds, and then repeats sequence.

Honeywell EI Ignition Module Green LED Status Codes

Green LED Flash Code (X + Y) ^a	Indicates	Next System Action	Recommended Service Action
OFF	No "Call for Heat"	N/A	None
Flash Fast	Startup - Flame sense calibration	N/A	None
Heartbeat	Normal operation	N/A	None
2	5 minute Retry Delay- Pilot flame not detected during trial for ignition	Initiate new trial for ignition after retry delay completed.	If system fails to light on next trial for ignition check gas supply, pilot burner, spark and flame sense wiring, flame rod contamination or out of position, burner ground connection.
3	Recycle- Flame failed during run	Initiate new trial for ignition. Flash code will remain through the ignition trial until flame is proved.	If system fails to light on next trial for ignition check gas supply, pilot burner, flame sense wiring, flame rod contamination, burner ground connection.
4	Flame sensed out of sequence	If situation self corrects within 10 seconds, control returns to normal sequence. If flame out of sequence remains longer than 10 seconds, control goes to Flash code 6+4 (see below)	Check for pilot flame. Replace gas valve if pilot flame present. If no pilot flame, cycle "Call for Heat." If error repeats, replace control.
7	Flame sense leakage to ground	Control remains in wait mode. When the fault corrects, control resumes normal operation after a one minute delay.	Check flame sense lead wire for damage or shorting. Check that flame rod is in proper position. Check flame rod ceramic for cracks, damage or tracking.
8	Low secondary voltage supply- (below 15.5 Vac)	Control remains in wait mode. When the fault corrects, control resumes normal operation after one minute delay.	Check transformer and AC line for proper input voltage to the control. Check with full system load on the transformer.
6 + 2	5 minute Retry Delay- On every third retry on same "Call for Heat"	Initiate new trial for ignition after retry delay completed.	Check gas supply, pilot burner, spark and flame sense wiring, flame rod contamination or out of position, burner ground connection.
6 + 3	On every 6th flame failure during run on the same "Call for Heat"	5 minute retry delay, then initiate new trial for ignition.	Check gas supply, pilot burner, flame sense wiring, contamination of flame rod, burner ground connection.
6 + 4	Flame sensed out of sequence- longer than 10 seconds	Control waits until flame is no longer sensed and then goes to soft lockout. Flash code continues. Control auto resets from soft lockout after one hour.	Check for pilot flame. Replace gas valve if pilot flame present. If no pilot flame, cycle "Call for Heat." If error repeats, replace control.
ON	Soft lockout due to error detected during self check sequences	Control auto resets from soft lockout after one hour.	Reset by cycling "Call for Heat." If error repeats, replace the control

^aFlash Code Descriptions:

- Flash Fast: rapid blinking
- Heartbeat: Constant ½ second bright, ½ second dim cycles.
- A single flash code number signifies that the LED flashes X times at 2Hz, remains off for two seconds, and then repeats the sequence.
- X + Y flash codes signify that the LED flashes X times at 2Hz, remains off for two seconds, flashes Y times at 2 Hz, remains off for three seconds, and then repeats the sequence.

Honeywell EI Trouble Shooting Guide

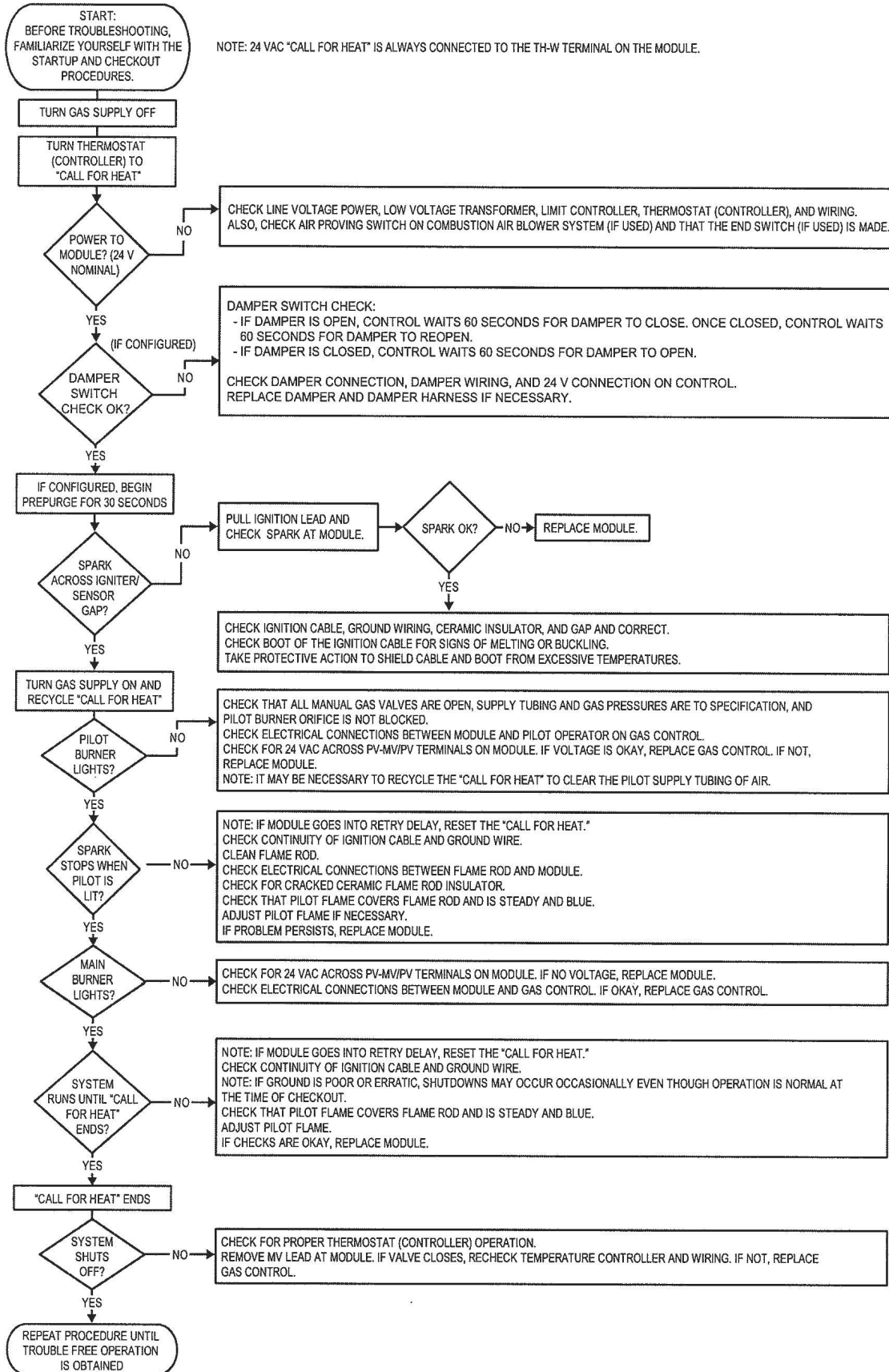

THIS PAGE LEFT BLANK INTENTIONALLY

X. Repair Parts

All Series 16H Repair Parts may be obtained through your local Crown wholesale distributor. Should you require assistance in locating a Crown distributor in your area, or have questions regarding the availability of Crown products or repair parts, please contact Crown Customer Service at: 215-535-8900 or Fax (215) 535-9736.

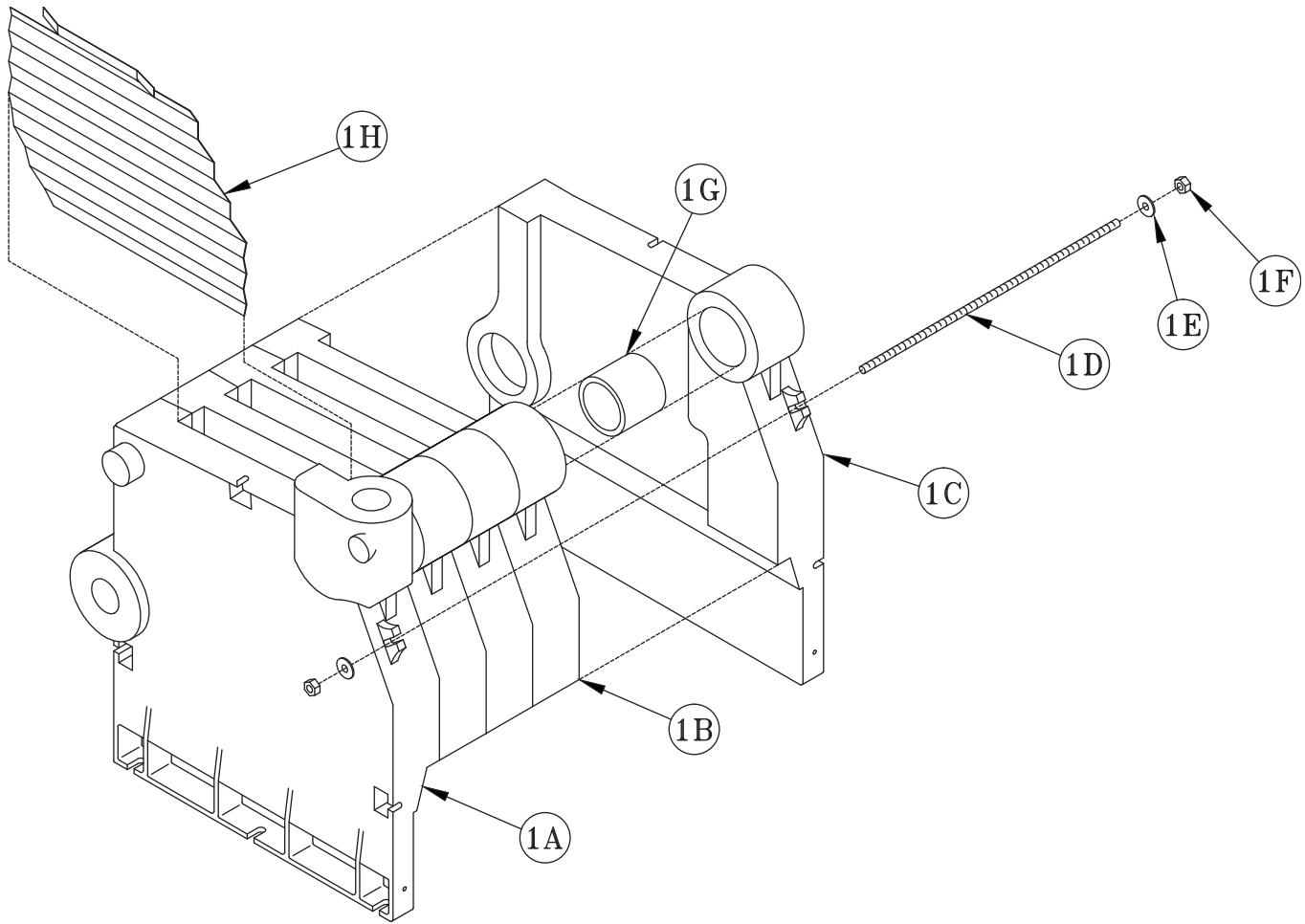

Item No.	Description	Part No.	Quantity			
			16H-340	16H-410	16H-460	16H-505
1. Heat Exchanger Assembly						
1	Complete (Less Flue Baffles)	6171607	1	---	---	---
		6171608	---	1	---	---
		6171609	---	---	1	---
		6171610	---	---	---	1
1A	Left End Section	7171601	1	1	1	1
1B	Intermediate Section	7171603	5	6	7	8
1C	Right End Section	7171602	1	1	1	1
1D	Tie Rod	80861013	1	---	---	---
		80861034	---	1	---	---
		80861035	---	---	1	---
		80861036	---	---	---	1
1E	Washer	Procure Locally	4	4	4	4
1F	Nut	Procure Locally	4	4	4	4
1G	Slip Nipple, 3" (Upper & Lower)	7066002	12	14	16	18
1H	Flue Baffle	7111623	6	7	8	9

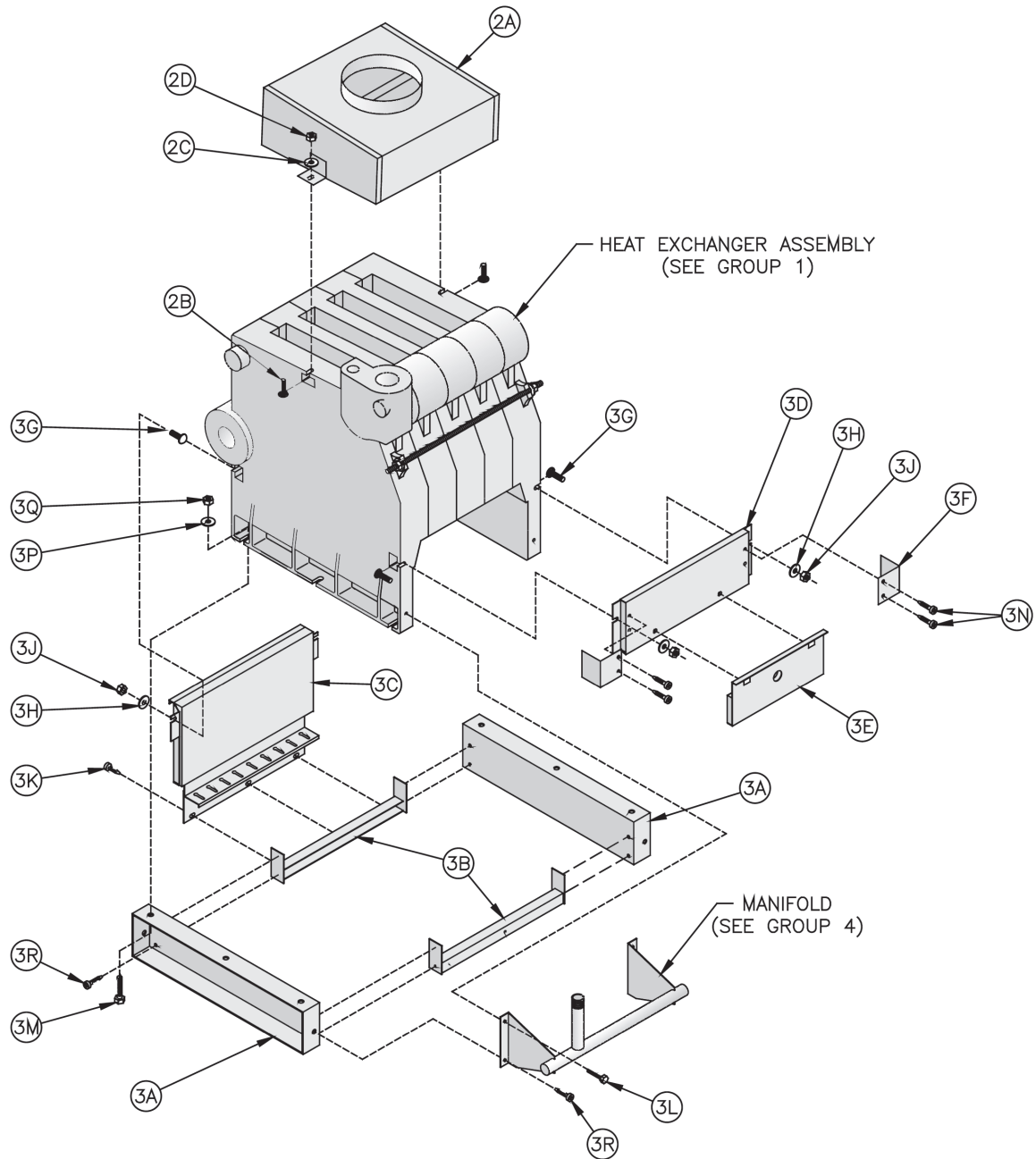

Item No.	Description	Part No.	Quantity			
			16H-340	16H-410	16H-460	16H-505
2. Canopy						
2A	Canopy	61116071	1	---	---	---
		260128	---	1	---	---
		61116091	---	---	1	---
		61116110	---	---	---	1
2B	Bolt, Carriage, 1/4 - 20 x 1"	Procure Locally	2	2	2	2
2C	Washer, 1/4" Flat	Procure Locally	2	2	2	2
2D	Nut, 1/4" - 20	Procure Locally	2	2	2	2

Item No.	Description	Part No.	Quantity			
			16H-340	16H-410	16H-460	16H-505
3. Base Assembly						
3A	Base End Panel	260660	2	2	2	2
3B	Base Channel Assembly	260647	2	---	---	---
		260648	---	2	---	---
		260649	---	---	2	---
		260650	---	---	---	2
3C	Base Rear Panel Assembly	260667	1	---	---	---
		260668	---	1	---	---
		260669	---	---	1	---
		260670	---	---	---	1
3D	Base Front Panel Assembly	260607	1	---	---	---
		260608	---	1	---	---
		260609	---	---	1	---
		260610	---	---	---	1
3E	Burner Access Panel Assembly	260627	1	---	---	---
		260628	---	2	---	---
		260629	---	---	2	---
		260630	---	---	---	2
3F	Jacket Attachment Bracket	7041601	4	4	4	4
3G	Bolt, Carriage, ¼ - 20 x 1¼"	Procure Locally	4	4	4	4
3H	Washer, ¼" Flat	Procure Locally	4	4	4	4
3J	Nut, ¼ - 20	Procure Locally	4	4	4	4
3K	Screw, Self Tapping, ¼ - 20 x ½"	Procure Locally	4	5	5	6
3L	Screw, Cap, Hex Head, 5/16" - 18 x ¾"	Procure Locally	2	2	2	2
3M	Screw, Cap, Hex Head, 5/16 - 18 x 1¼"	Procure Locally	6	6	6	6
3N	Screw, Sheet Metal, #8 x ½"	Procure Locally	8	8	8	8
3P	Washer, 3/8" Flat	Procure Locally	6	6	6	6
3Q	Nut, 5/16"	Procure Locally	6	6	6	6
3R	Screw, Self Tapping, ¼ - 20 x ¾"	Procure Locally	10	10	10	10

Item No.	Description	Part No.				
			16H-340	16H-410	16H-460	16H-505
4. Manifold and Main Burners						
4A	Main Burner	150161	12	15	17	19
4B	Main burner with Pilot Bracket, Honeywell EI	150160	1	1	1	1
	Main burner with Pilot Bracket, EP	8231603	1	1	1	1
4C	Manifold	260157	1	---	---	---
		260158	---	1	---	---
		260159	---	---	1	---
		260160	---	---	---	1
4D	Pipe Plug, 1/8 NPT (Included with 4C)	---	1	1	1	1
4E	Main Burner Orifice, #41 (Natural Gas Only) *	950351	13	16	18	20
	Main Burner Orifice, #53 (LP/Propane Only) *	950365	13	16	18	20
4F	Hitch Pin Clip	950370	13	16	18	20

* Main burner orifice sizes shown for normal altitude (0-2000 feet). For High Altitude consult factory.

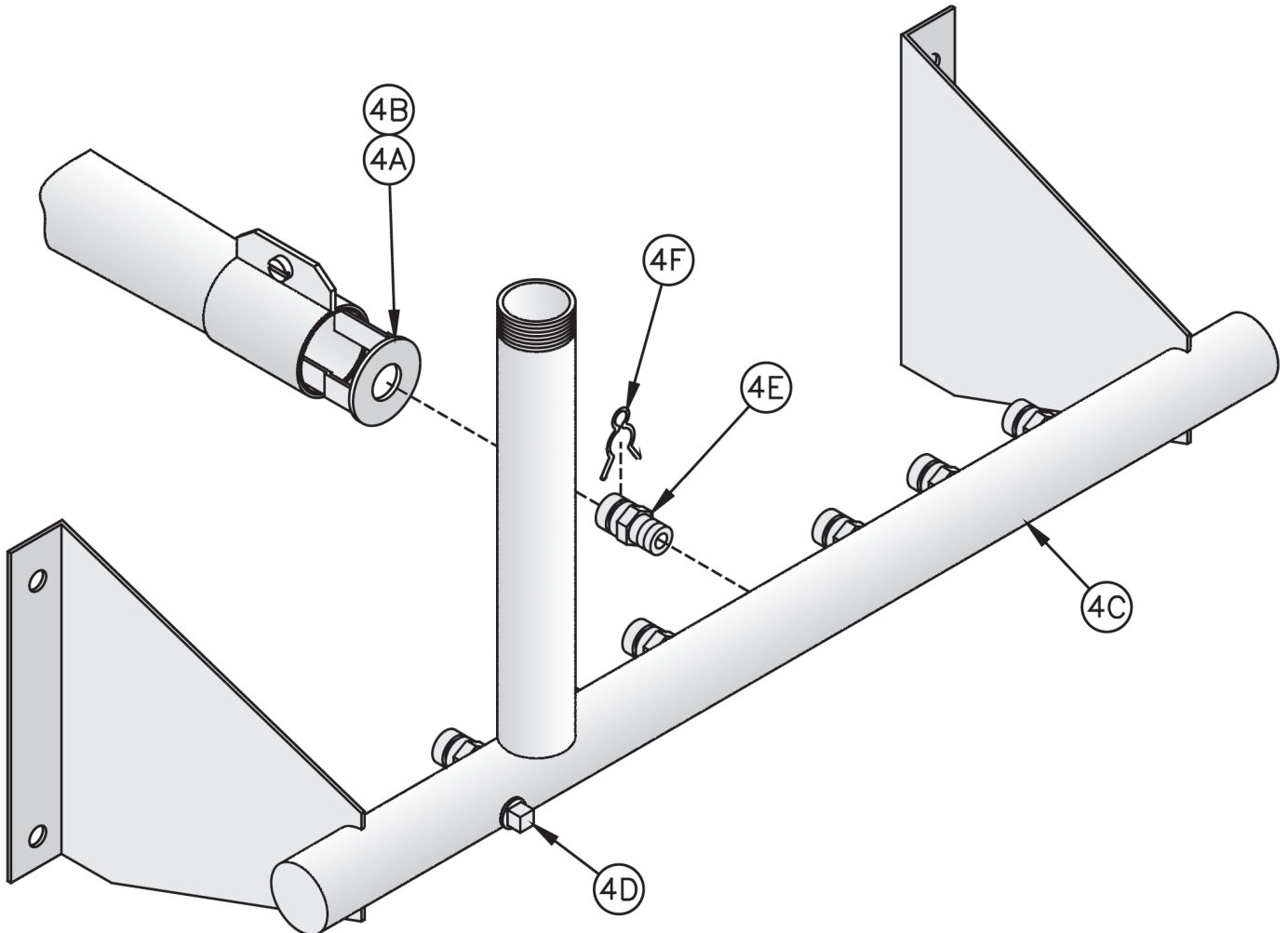

Item No.	Description	Part No.	Size	Quantity
5-3 Gas Train -- Intermittent Ignition (EI)				
USA: 7 - 10 Section, Natural and LP Gas				
A	Gas Valve, Robertshaw 7000DERHC, Natural Gas, 1" NPT	3507310	16H-340 THRU 16H-505	1
	Gas Valve, Robertshaw 7000DERHC-LP, LP Gas, 1" NPT	3507315	16H-340 THRU 16H-505	
B	Conbraco 50GB501A Manual Shut-Off Valve, 1" NPT	822615	16H-410 THRU 16H-505	1
C	Nipple, 1" NPT x 2" Lg.	950102		
D	Street Elbow, 1" NPT	950191	16H-340	1
	Street Elbow, 1¼" NPT x 1" NPT	950193	16H-410 THRU 16H-505	

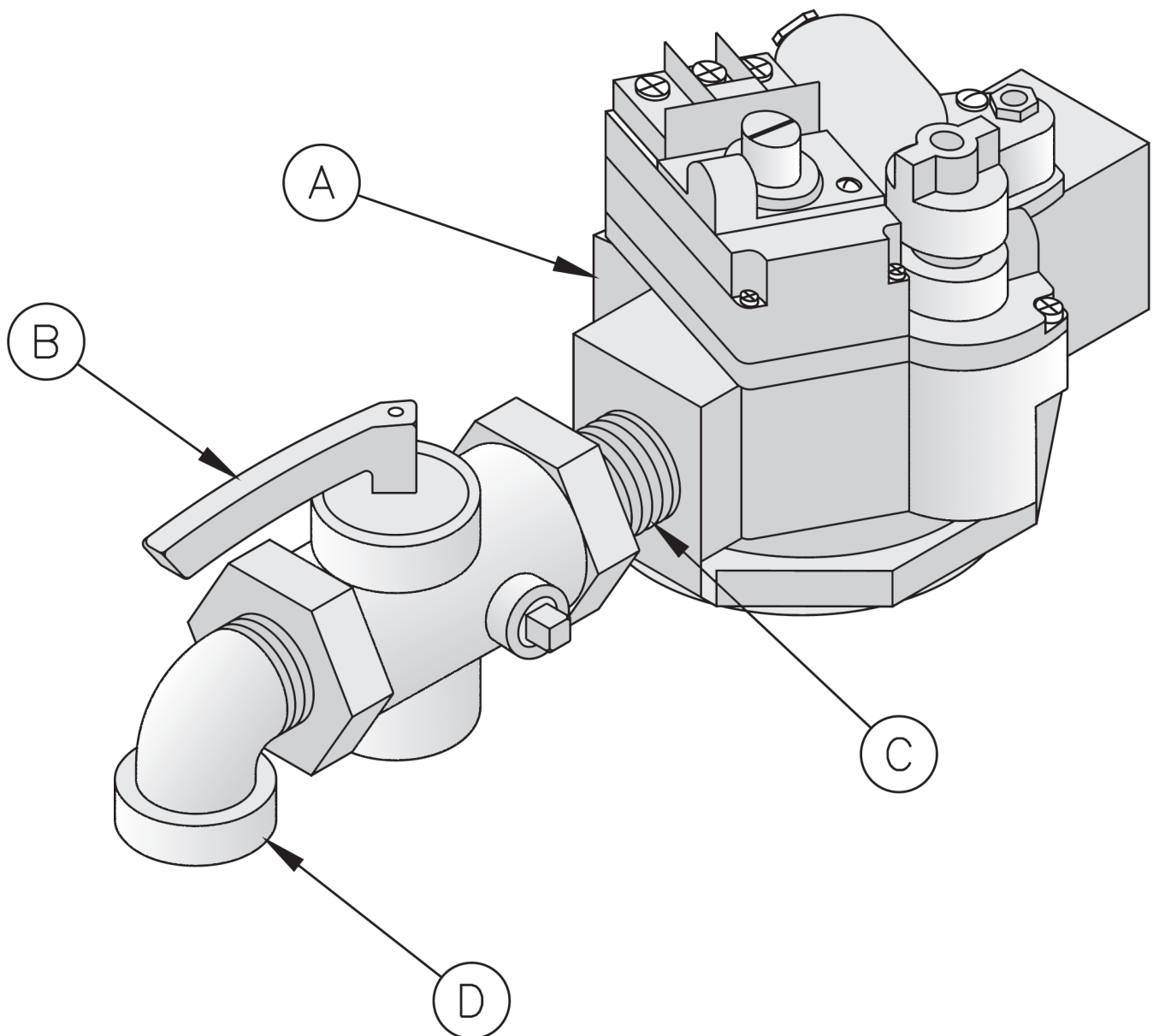

Item No.	Description	Part No.	Quantity
5-4 Gas Train -- Intermittent Ignition (EP-CSD-1)			
USA Only: 8 - 10 Section, Natural Gas Only			
A	Gas Valve, Robertshaw 7000GVERHC-S7C, Natural Gas, 1" NPT	81660168	1
B	Solenoid Gas Valve, Honeywell V8295A1032, 1" NPT	81660236	1
C	Manual Shut-Off Valve, Conbraco #50-403-02, 1" NPT	822615	1
D	Leak Test/Shut-Off Valve, Conbraco #50GB501A, 1/8" x 1/8"	822679	2
E	Pipe Plug, 1/8"	Procure Locally	2
F	Hex Bushing, 1/4" x 1/8"	Procure Locally	1
G	Nipple, 1" x 2" Long	806600004	1
H	Street Elbow, 90° x 1 1/4" NPT x 1" NPT (Shipped Loose In P&C Carton)	806601513	1
J	Close Nipple, 1"	806600033	1
L	Wiring Harness, Gas Valve to Solenoid Valve	6136230	1
M	Pilot Outlet Plug, Honeywell #394424	8226051	1

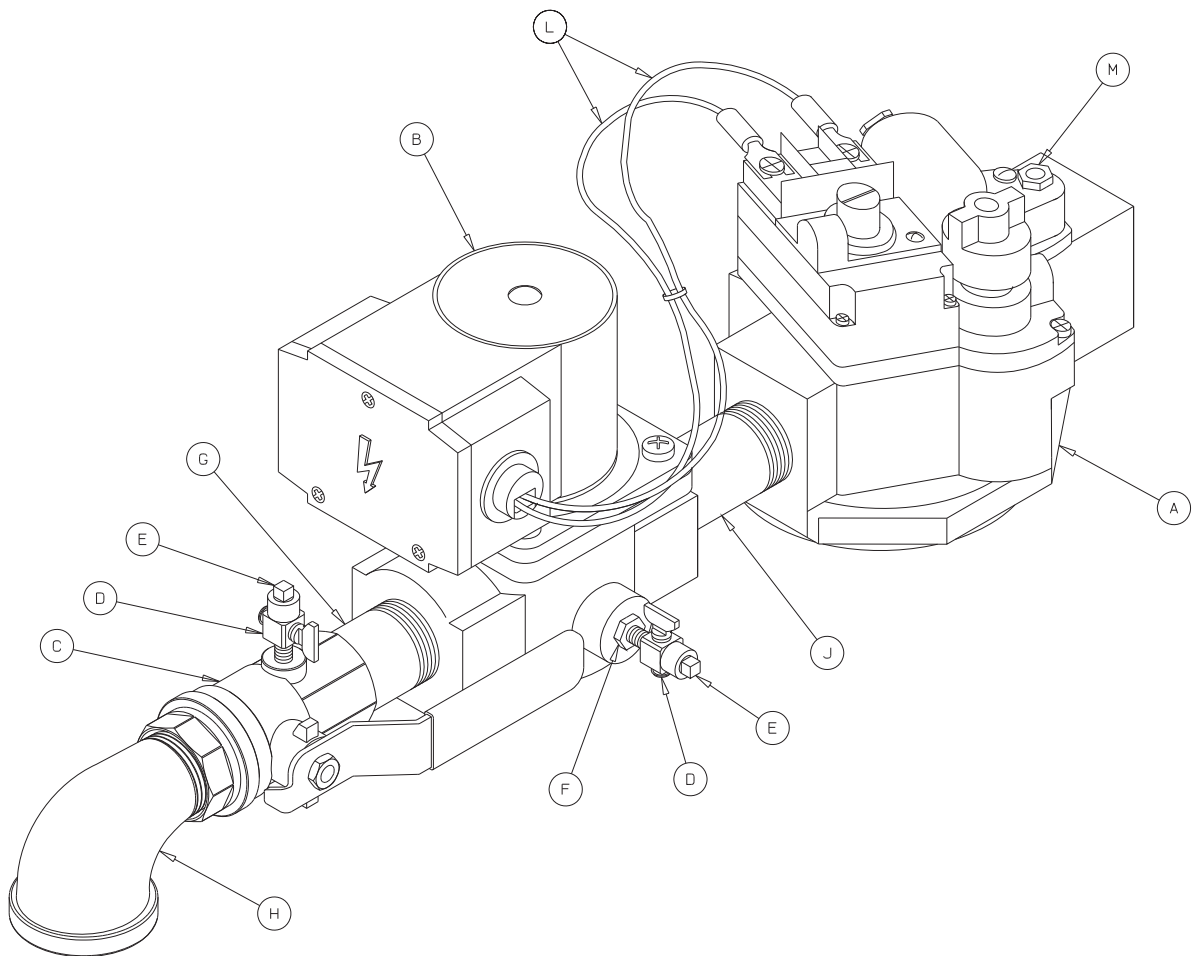

Item No.	Description	Part No.	Size	Quantity
5-6 Pilot Assembly and Piping -- Intermittent Ignition (Honeywell EI) USA				
7 - 10 Section, Natural and LP Gas				
A	Pilot Burner, Honeywell Q3481B1206, Natural Gas	103704-01	16H-340 - 16H-505	1
	Pilot Burner, Honeywell Q3481B1420, LP Gas	103705-01		
B	Brass Compression Union, 1/4" OD Tube	8236008		1

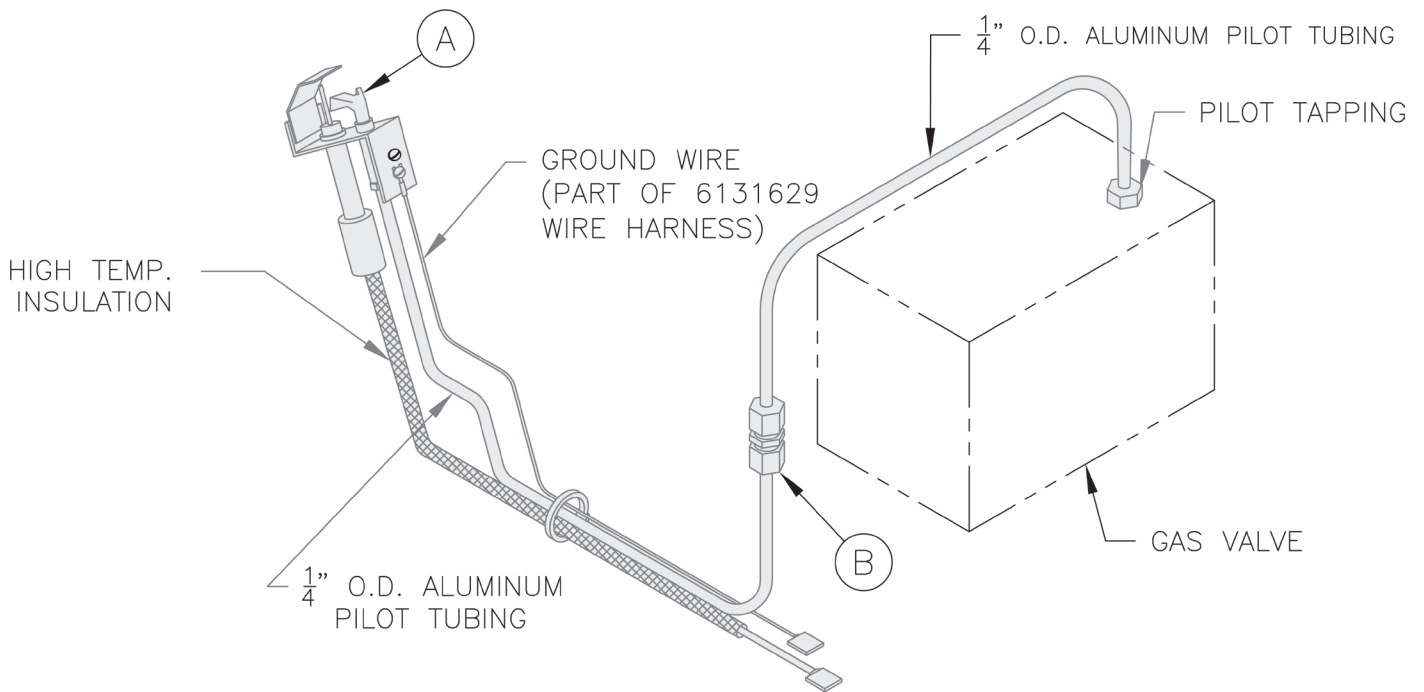

Item No.	Description	Part No.	Size	Quantity
5-9 Pilot Assembly and Piping -- Intermittent Ignition (EP-CSD-1)				
USA Only: 8 - 10 Section, Natural Gas Only				
A	Pilot Burner, Honeywell Q179C1009, Natural Gas	8236017	16H-410 - 16H-505	1
B	Flame Rod Lead, Honeywell R1298020, 4 Ft. Lg.	71362561		1
C	Rajah Connector, Honeywell 37356	8236021		2
D	Ignition Lead, Honeywell R1061012, 3 Ft. Lg.	7136247		1
E	Ground Wire Assembly	6136259		1
F	Brass Compression Coupling, 1/4" OD Tube	8236008		1
G	Conbraco Leak Test / Shut-Off Cock, 1/8" x 1/8"	822679		1
H	Brass Compression Adapter, 1/4" OD Tube x 1/8" NPT	822630		2
J	Solenoid Gas Valve, Johnson H91WA-4	822662		1
K	Junction Box, 4" Sq. x 1-1/2" Deep	96-055		1
L	Rigid Conduit Nipple, 1/2" NPT x 1-1/2" Lg.	Procure Locally		1
M	Conduit Locknut, 1/2"	Procure Locally		2
N	Plastic Insulating Bushing, 1/2"	96-011		1
P	Regulator, Maxitrol RV12LT, Natural / LP Gas	8226005		1

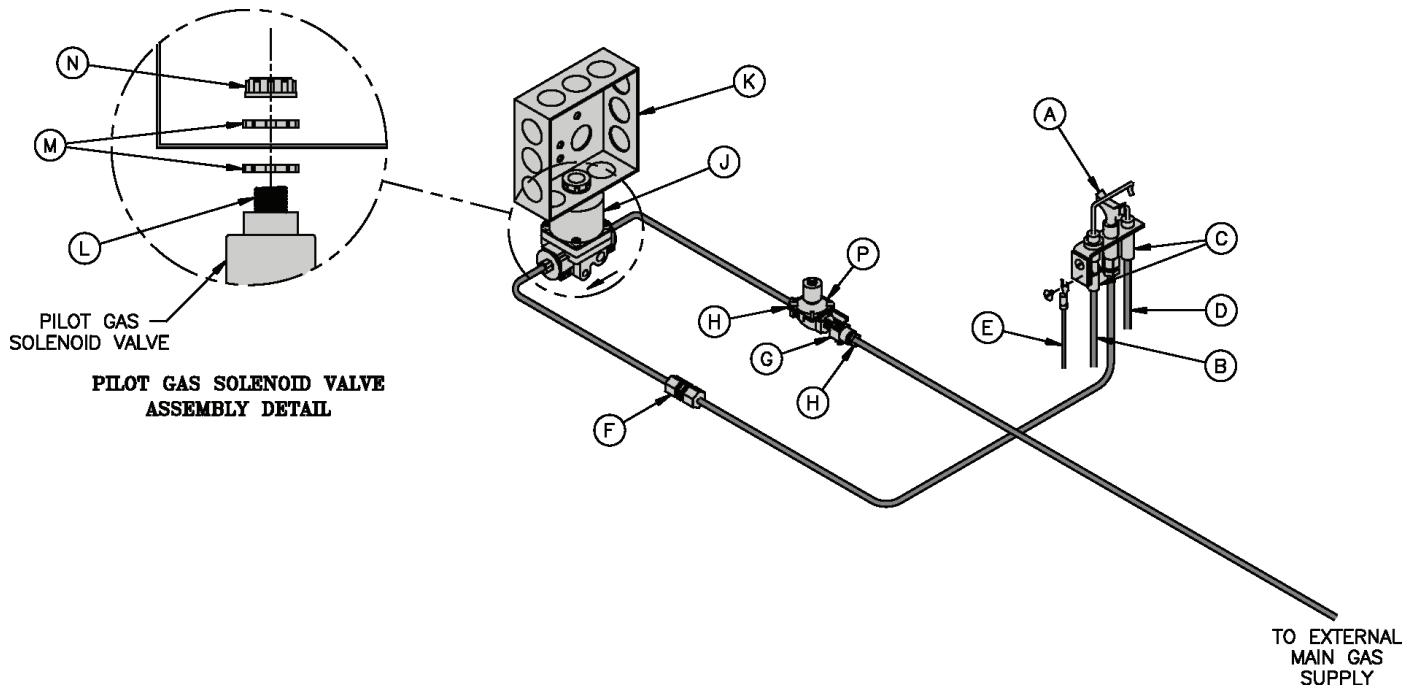

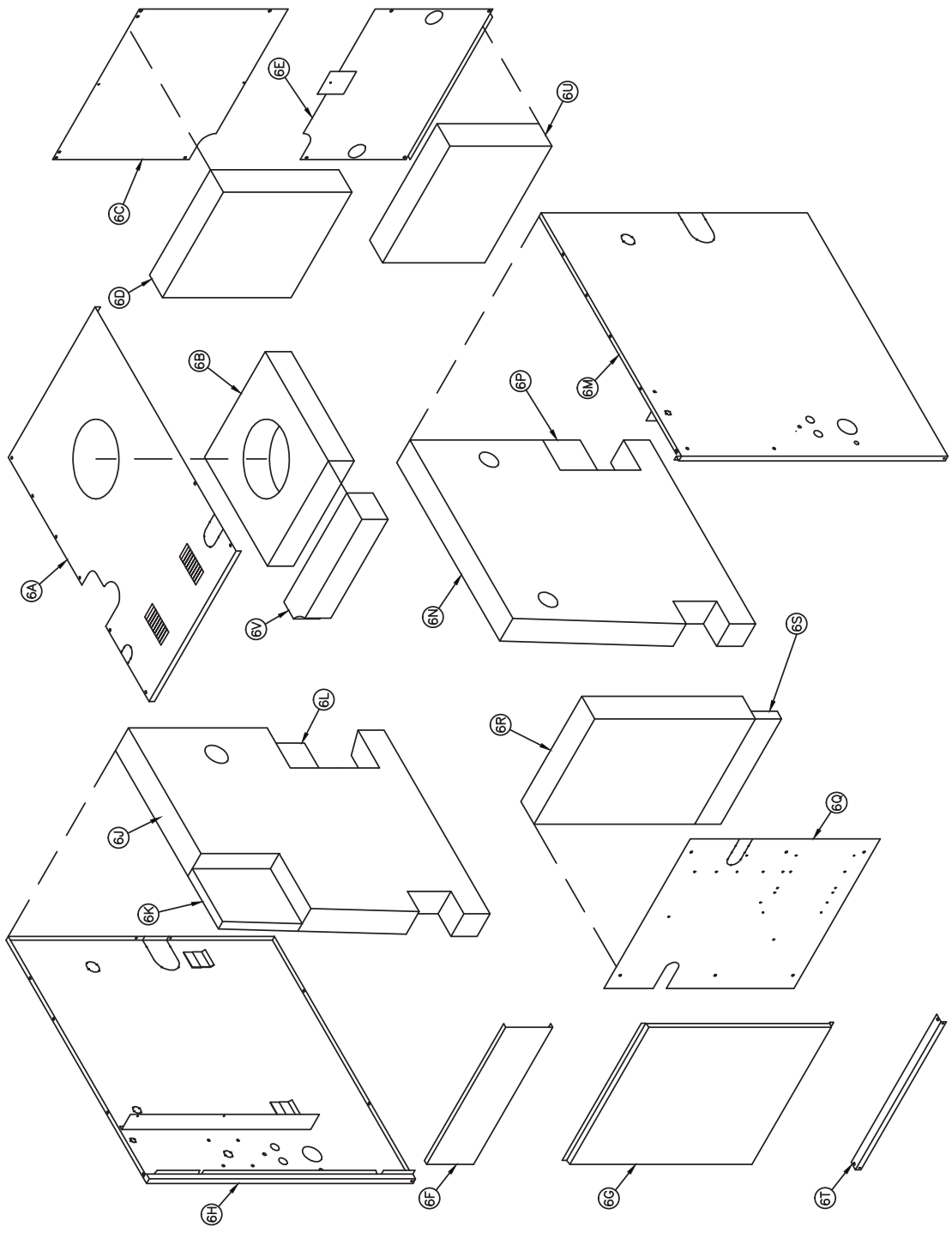

Item No.	Description	Part No.	Quantity			
			16H-340	16H-410	16H-460	16H-505
6. Jacket						
6	Complete	60416131	1	---	---	---
		60416141	---	1	---	---
		60416151	---	---	1	---
		60416161	---	---	---	1
6A	Jacket Top Panel	704160793	1	---	---	---
		704160893	---	1	---	---
		704160993	---	---	1	---
		704161093	---	---	---	1
6B	Jacket Top Panel Main Insulation	7201611	1	---	---	---
		7201613	---	1	---	---
		7201615	---	---	1	---
		7201617	---	---	---	1
6C	Jacket Upper Rear Panel	704160795	1	---	---	---
		704160895	---	1	---	---
		704160995	---	---	1	---
		704161095	---	---	---	1
6D	Jacket Upper Rear Panel Insulation	72016079	1	---	---	---
		72016089	---	1	---	---
		72016099	---	---	1	---
		72016109	---	---	---	1
6E	Jacket Lower Rear Panel	60416079	1	---	---	---
		60416089	---	1	---	---
		60416099	---	---	1	---
		60416109	---	---	---	1
6F	Jacket Upper Front Panel	704160791	1	---	---	---
		704160891	---	1	---	---
		704160991	---	---	1	---
		704161091	---	---	---	1
6G	Jacket Front Removable Panel	70416079	1	---	---	---
		70416089	---	1	---	---
		70416099	---	---	1	---
		70416109	---	---	---	1
6H	Jacket Left Side Panel	60416011	1	1	1	1
6J	Jacket Left Side Panel Main Insulation Piece	72016021	1	1	1	1
6K	Jacket Left Side Panel Upper Corner Insulation Piece	72016023	1	1	1	1
6L	Jacket Left Side Panel Lower Corner Insulation Piece	72016022	1	1	1	1
6M	Jacket Right Side Panel	60416021	1	1	1	1
6N	Jacket Right Side Panel Main Insulation Piece	72016011	1	1	1	1
6P	Jacket Right Side Panel Lower Corner Insulation Piece	72016012	1	1	1	1
6Q	Jacket Vestibule Panel	704160794	1	---	---	---
		704160894	---	1	---	---
		704160994	---	---	1	---
		704161094	---	---	---	1
6R	Jacket Vestibule Panel Upper Insulation Piece	72016077	1	---	---	---
		72016087	---	1	---	---
		72016097	---	---	1	---
		72016107	---	---	---	1

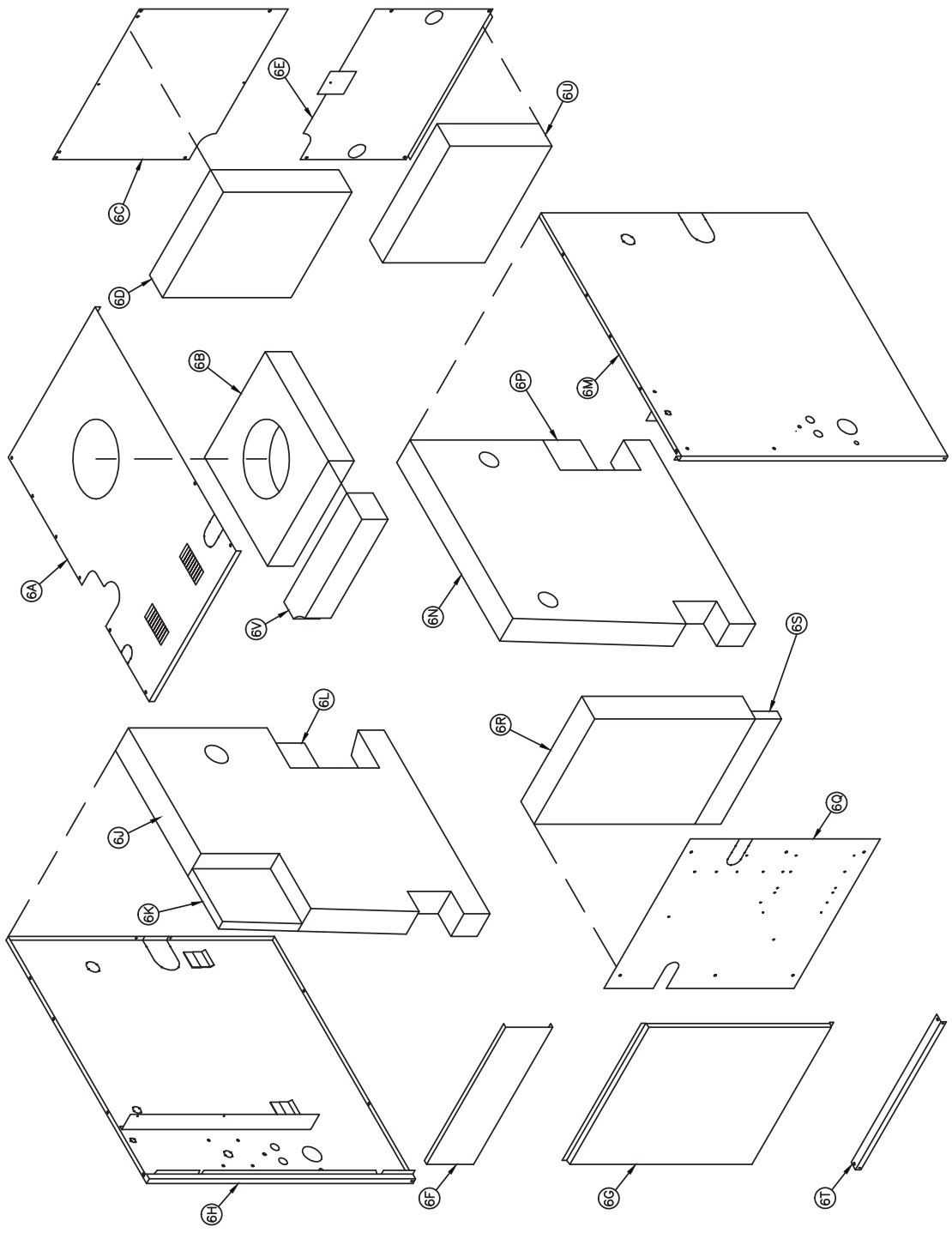

Item No.	Description	Part No.	Quantity			
			16H-340	16H-410	16H-460	16H-505
6. Jacket (Continued)						
6S	Jacket Vestibule Panel Lower Insulation Piece	72016076	1	---	---	---
		72016086	---	1	---	---
		72016096	---	---	1	---
		72016106	---	---	---	1
6T	Jacket Lower Front Tie Bar	704160792	1	---	---	---
		704160892	---	1	---	---
		704160992	---	---	1	---
		704161092	---	---	---	1
6U	Jacket Lower Rear Panel Insulation	7201619	1	---	---	---
		7201620	---	1	---	---
		7201621	---	---	1	---
		7201622	---	---	---	1
6V	Jacket Top Panel Front Insulation	7201612	1	---	---	---
		7201614	---	1	---	---
		7201616	---	---	1	---
		7201618	---	---	---	1

Item No.	Description	Part No.	Quantity			
			16H-340	16H-410	16H-460	16H-505
7. Trim and Miscellaneous Controls						
A	Limit, 140-220°F, Honeywell L4080D1218 (EI) L4080B1212 (EP)	35-3300 80160474	1	1	1	1
	Immersion Well, ¾" NPT x 1½" Insul. Depth	35-1010	1	1	1	1
B	Limit, Manual Reset, Honeywell L4006E1133	3503101	Optional on EI, Standard on EP-CSD-1	Optional on EI, Standard on EP-CSD-1	Optional on EI, Standard on EP-CSD-1	Optional on EI, Standard on EP-CSD-1
B1	Immersion Well, ¾" NPT x 3" Insul. Depth	35-1020	1	1	1	1
C	Temperature - Pressure Gauge	95-069	1	1	1	1
C1	Nipple, 2 NPT x 10" w/Gauge Tapping	950210	1	1	1	1
D	Safety Relief Valve, ¾ NPT, 50 psi	81660302	1	1	1	1
D1	Nipple, ¾ NPT x 3½"	Procure Locally	1	1	1	1
E	Drain Valve, ¾ NPT, Conbraco 35-302-03	95-041	1	1	1	1
E1	Nipple, ¾ NPT x 3½"	Procure Locally	1	1	1	1
E2	Coupling, ¾ NPT	95-056	1	1	1	1
F	Blocked Vent Switch Replacement Assembly	6016058	1	1	1	1
G	Flame Roll-out Switch	960122	1	1	1	1
G1	Flame Roll-out Switch Mounting Bracket	900122	1	1	1	1
H	Junction Box	96-055	1	1	1	1
J	Control Center, Honeywell R8285D5001 (Intermittent Circulation builds)	3505555	1	1	1	1
L	Ignition Module, Honeywell S8610M3009	3505020	1	1	1	1
M	Vestibule Wiring Harness, Complete with Vent Damper Bypass Plug (EI) (Not Depicted)	81316010	1	---	---	---
		81316011	---	1	1	1

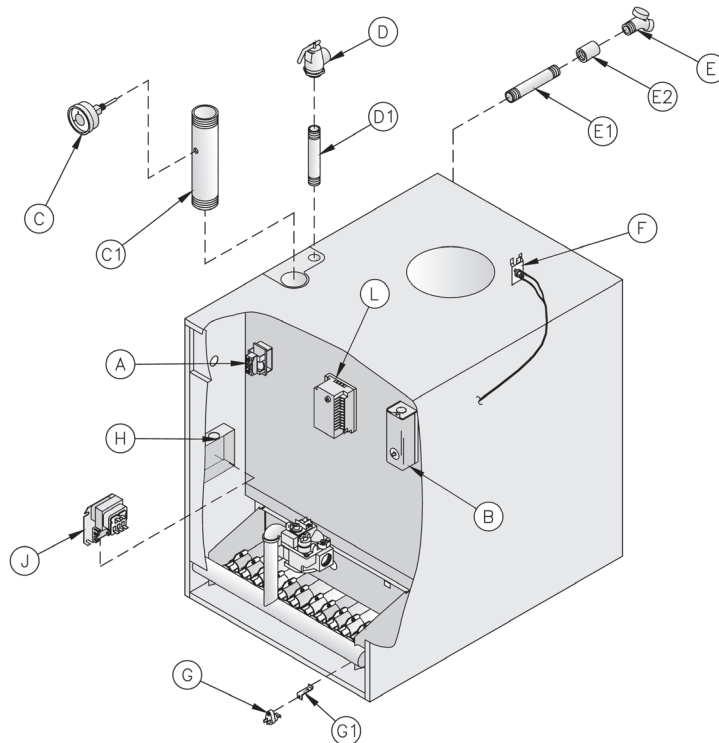

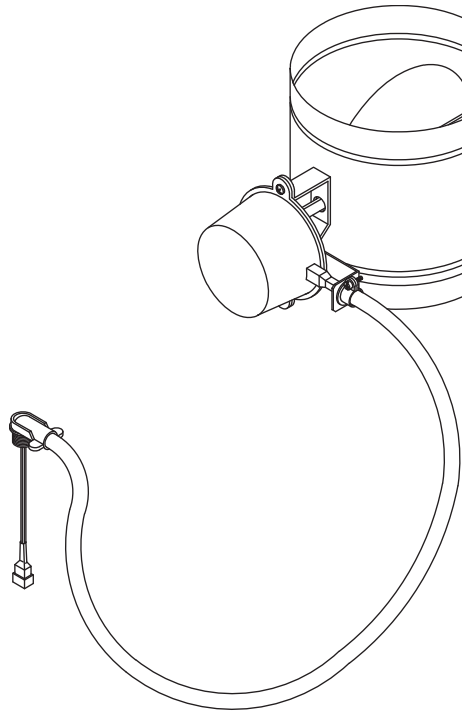

VENT DAMPER

OPTIONAL: 16H-340 THRU 16H-505

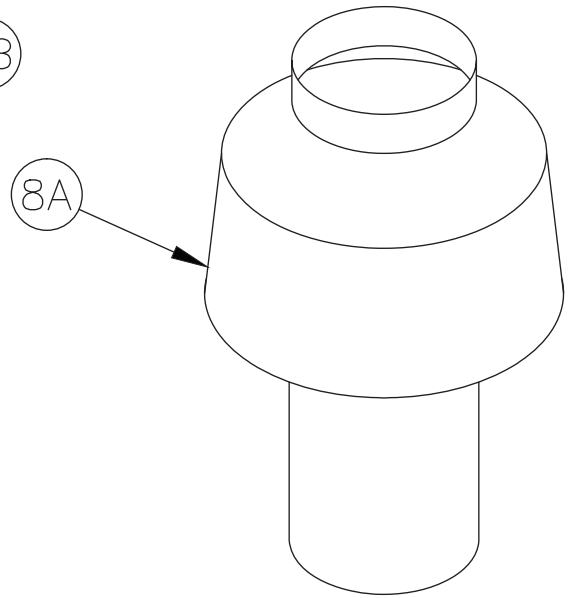

DRAFT HOOD

Item No.	Description	Part No.	Quantity			
			16H-340	16H-410	16H-460	16H-505
8. Draft Hood and Automatic Vent Damper						
8A	Draft Hood	260136	1	---	---	---
		260138	---	1	---	---
		260139	---	---	1	1
8B	Automatic Vent Damper, 8"	96-035	1	---	---	---
	Automatic Vent Damper, 9"	96-036	---	1	---	---
	Automatic Vent Damper, 10"	96-037	---	---	1	1



Manufacturer of Hydronic Heating Products
P.O. Box 14818 3633 I. Street
Philadelphia, PA 19134
www.crownboiler.com

PN: 980415
Series 16H
Rev 5 - 6/15