



PHANTOM[®]
COMBI

**NEW High Efficiency
Gas Fired, Stainless
Steel, Condensing
Combi Boiler**



- 95% AFUE with 10:1 turndown
- Reliable, proven stainless steel heat exchanger technology
- Flat plate heat exchanger provides superb domestic hot water performance
- Factory preset Honeywell Sola control system for out-of-the-box performance.
- Touch screen diagnostic display with plain-language guidance
- FREE 5-year parts warranty included
- Low NOx
- Field Convertible to LP gas with optional kit.

Additional Built-in Features

- Universal boiler vent connection for polypropylene, CPVC/PVC & stainless steel
- Outdoor reset and sensor

**Quality
Value &
Service**

PHANTOM COMBI

TECHNICAL SPECIFICATIONS

Typical Venting Configurations (Horizontal and Vertical) up to 135 sq. ft.

Illustrations are for representation only. For complete venting information, please see installation manual.

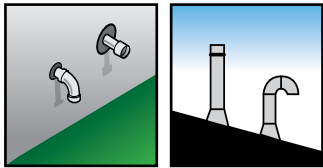

Horizontal 2-pipe Vertical 2-pipe

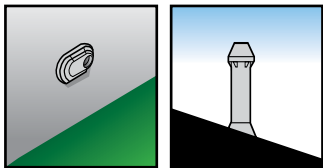

Horizontal 2-pipe low profile Vertical 2-pipe concentric

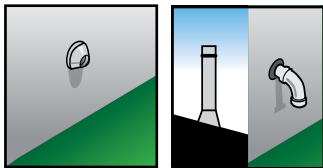

Horizontal 2-pipe concentric Hybrid

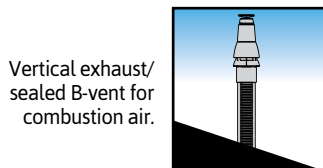

Vertical exhaust/sealed B-vent for combustion air.

PLUS polypropylene & stainless steel chimney chase options

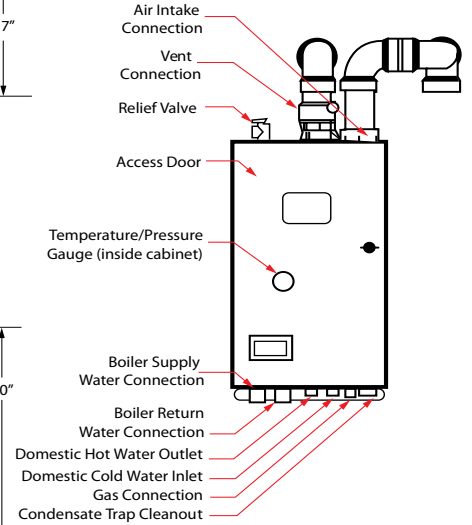
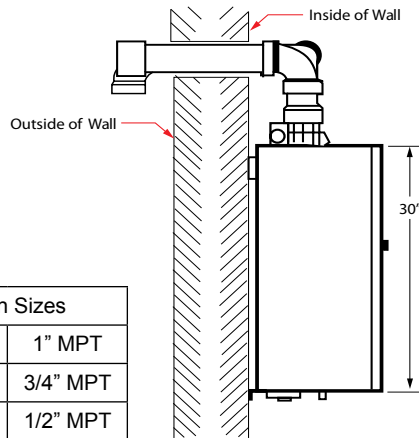
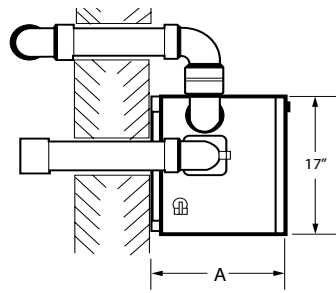

Connection Sizes	
Supply/Return	1" MPT
DHW	3/4" MPT
Gas	1/2" MPT
Vent	3"

Model(s)	"A" DIMENSION
PHNTM135CB	15"
PHNTM150CB & 180CB	19"

Space Heating Ratings					Domestic Hot Water (DHW) Ratings ¹			Approx. Shipping Weight (lbs)
Model Number	Input (MBH) Min-Max	Heating Capacity, MBH	Net AHRI Water, MBH ²	AFUE, %	Input (MBH) Min-Max	Max Draw GPM ^{3,4}		
						70°F Rise	77°F Rise	
PHNTM135CB	12-120	112	97	95.0	12-135	3.3	3.0	152
PHNTM150CB	15-150	142	123	95.0	15-150	3.9	3.7	169
PHNTM180CB ⁵	18-180	169	147	95.0	18-180	4.5	4.1	169

Notes:

- DHW ratings are not AHRI certified.
- The Net AHRI Water Ratings shown are based on a piping and pickup allowance of 1.15. The manufacturer should be consulted before selecting a boiler for installations having unusual piping and pickup requirements, such as intermittent system operation, extensive piping systems, etc.
- Maximum draw rates shown are at sea level and minimum vent length. Under other conditions draw rates will be reduced proportionally to the reduction in input. See manual for input derate information.
- Minimum flow rate of 0.56GPM required through the boiler to initiate a call for DHW. A higher flow rate may be required through the fixture due to mixing at the tempering valve and fixture itself.
- PHNTM180CB not for installation at altitudes above 2000 ft. Consult installation manual for limitations on 135CB and 150CB installations above 2000 ft.

STANDARD EQUIPMENT

- Stainless steel heat exchanger
- Pre-installed circulator and DHW 3-way valve
- SOLA Control System
 - LCD touch screen display
 - Self-guided control menus
 - Built-in self-diagnostics
 - Additional circulator output
 - Outdoor reset including outside sensor
 - DHW priority
 - Warm weather shutdown
- UL 353 Listed boiler flow switch
- Supply and return water sensors with integral high limit function
- Universal exhaust vent connection (CPVC/PVC, PP, SS)
- Pre-installed hanging bracket and wall mount kit
- Field adjustable for high altitude with minimal derate (135CB, 150CB)
- Installed domestic hot water flow switch and temperature sensor.

OPTIONAL EQUIPMENT

- All boilers shipped for use with natural gas; LP conversion kit sold separately. (135CB-150CB P/N 107874-01, 180CB P/N 107875-01)
- Sage Zone Panel
- Service parts kit (P/N: 106260-03)

